



Sealco Commercial Vehicle Products

602-253-1007

fax 800/222-2334

www.sealcovp.com

SPRING BRAKE PRIORITY  
4S/3M

- CONTROL LINE (BLUE-1/2")
- CONTROL LINE (BLUE-3/8")
- SUPPLY LINE (RED-1/2")
- - - SPRING BRAKE
- - - SERVICE BRAKE
- - - A/C ANTI COMPOUNDING
- PLUG ALL UNUSED PORTS

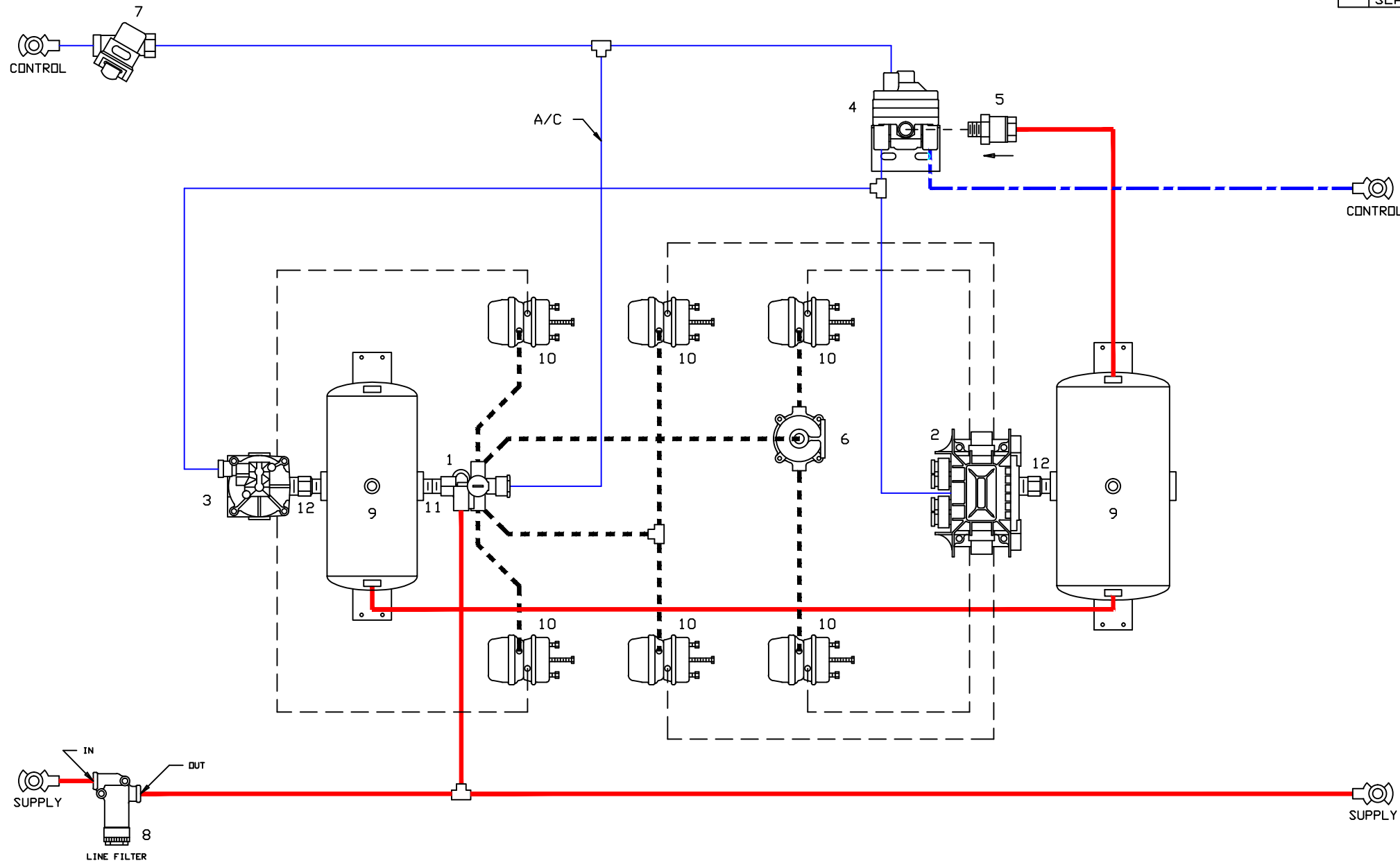

NO.	DESCRIPTION
1.	SEALCO NO. 110800 SPRING BRAKE CONTROL VALVE
2.	WABCO NO. 400 500 103 0 PREMIUM ECU ASSEMBLY
3.	WABCO NO. 472 195 033 0 ABS RELAY VALVE
4.	SEALCO NO. 110580 CONTROL LINE VALVE
5.	SEALCO NO. 10200-1/2 ONE WAY CHECK VALVE
6.	SEALCO NO. 200001 QUICK RELEASE VALVE
7.	WABCO NO. 432 500 005 0 CONTROL LINE VALVE
8.	SEALCO NO. 2550 LINE FILTER
9.	RESERVOIR - VOLUME TO BE AS PER FMVSS-121
10.	SPRING BRAKE & SERVICE BRAKE CHAMBER
11.	SEALCO NO. 6002 NIPPLE FOR 1/2 N. P. T. TANK PORT SEALCO NO. 6003 NIPPLE FOR 3/4 N. P. T. TANK PORT
12.	SEALCO NO. 616 NIPPLE FOR 1/2 N. P. T. TANK PORT SEALCO NO. 6006 NIPPLE FOR 3/4 N. P. T. TANK PORT

**SPRING BRAKE CONTROL VALVE**

SEALCO NO. 110800

- CONTROL PORT (1)-3/8 N. P. T.
- SUPPLY PORT (1)-3/8 N. P. T.
- RESERVOIR PORT (1)-1/2 N. P. T.
- DELIVERY PORT (4)-3/8 N. P. T.

**PREMIUM ECU & DOUBLE MODULATOR ASSEMBLY AS 4S/3M**

MERITOR WABCO NO. 400 500 103 0

- SUPPLY/RES PORT (2)-3/4 N. P. T.
- DELIVERY PORT (6)-3/8 N. P. T.
- CONTROL PORT (1)-1/4 N. P. T.

**ABS RELAY VALVE - 4 PORT**

MERITOR WABCO NO. 472 195 033 0

- SUPPLY/RES PORT (2)-3/4 N. P. T.
- DELIVERY PORT (4)-3/8 N. P. T.
- CONTROL PORT (1)-3/8 N. P. T.

**CONTROL LINE VALVE**

SEALCO NO. 110580

- CONTROL PORT (1)-3/8 N. P. T.
- RESERVOIR PORT (1)-1/2 N. P. T.
- DELIVERY PORT (2)-3/8 N. P. T.

IT IS THE RESPONSIBILITY OF THE VEHICLE MANUFACTURER TO ASSURE THAT EACH VEHICLE COMPLIES WITH FMVSS 121 AND ALL OTHER APPLICABLE FEDERAL AND STATE REGULATIONS.

SAC-APD0996

AIR SYSTEM DIAGRAM REQUESTED BY:

TRI AXLE B TRAIN LEAD TRAILER

DR:	CH:	DATE:	JOB NO:
MG		5-30-2018	P-7751