



# Sealco Commercial Vehicle Products

602-253-1007 fax 800/222-2334 www.sealcovp.com

- CONTROL LINE (BLUE-3/8")
- SUPPLY LINE (RED-1/2")
- A/C ANTI-COMPOUNGING
- PLUG ALL UNUSED PORTS
- - - - - SPRING BRAKE
- - - - - SERVICE BRAKE
- - - - - LIFT BAG

NO.	DESCRIPTION	NO.	DESCRIPTION
1	SEALCO NO. 110800 SPRING BRAKE CONTROL VALVE	8	SEALCO NO. 200004 QUICK RELEASE VALVE
2	MERITOR WABCO NO. 400 500 103 0 ECU VALVE ASSEMBLY	9	SEALCO NO. 780115 FREE WHEEL CONTROL VALVE FOR LIFT AXLE
3	SEALCO NO. 110410 RELAY VALVE	10	SEALCO NO. 780215 FREE WHEEL CONTROL VALVE FOR LIFT AXLE
4	SEALCO NO. 110570 CONTROL LINE VALVE	11	RESERVOIR - VOLUME TO BE AS PER FMVSS 121
5	SEALCO NO. 10200 - 1/2 ONE - WAY CHECK VALVE	12	SPRING BRAKE & SERVICE BRAKE CHAMBER
6	SEALCO NO. 2550 LINE FILTER	13	616 1/2" X 3/4" NIPPLE OR 6002 1/2" X 1/2" NIPPLE
7	MERITOR WABCO NO.432 500 005 0 CONTROL LINE FILTER	14	616 1/2" X 3/4" NIPPLE OR 6006 3/4" X 3/4" NIPPLE

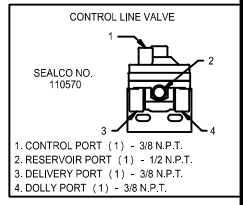
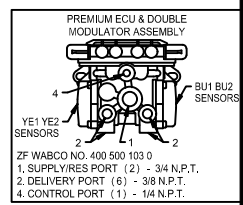
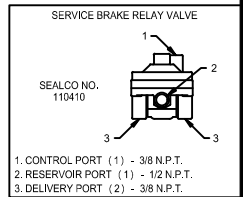
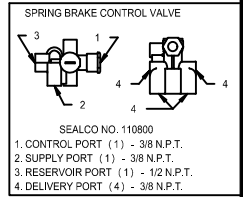
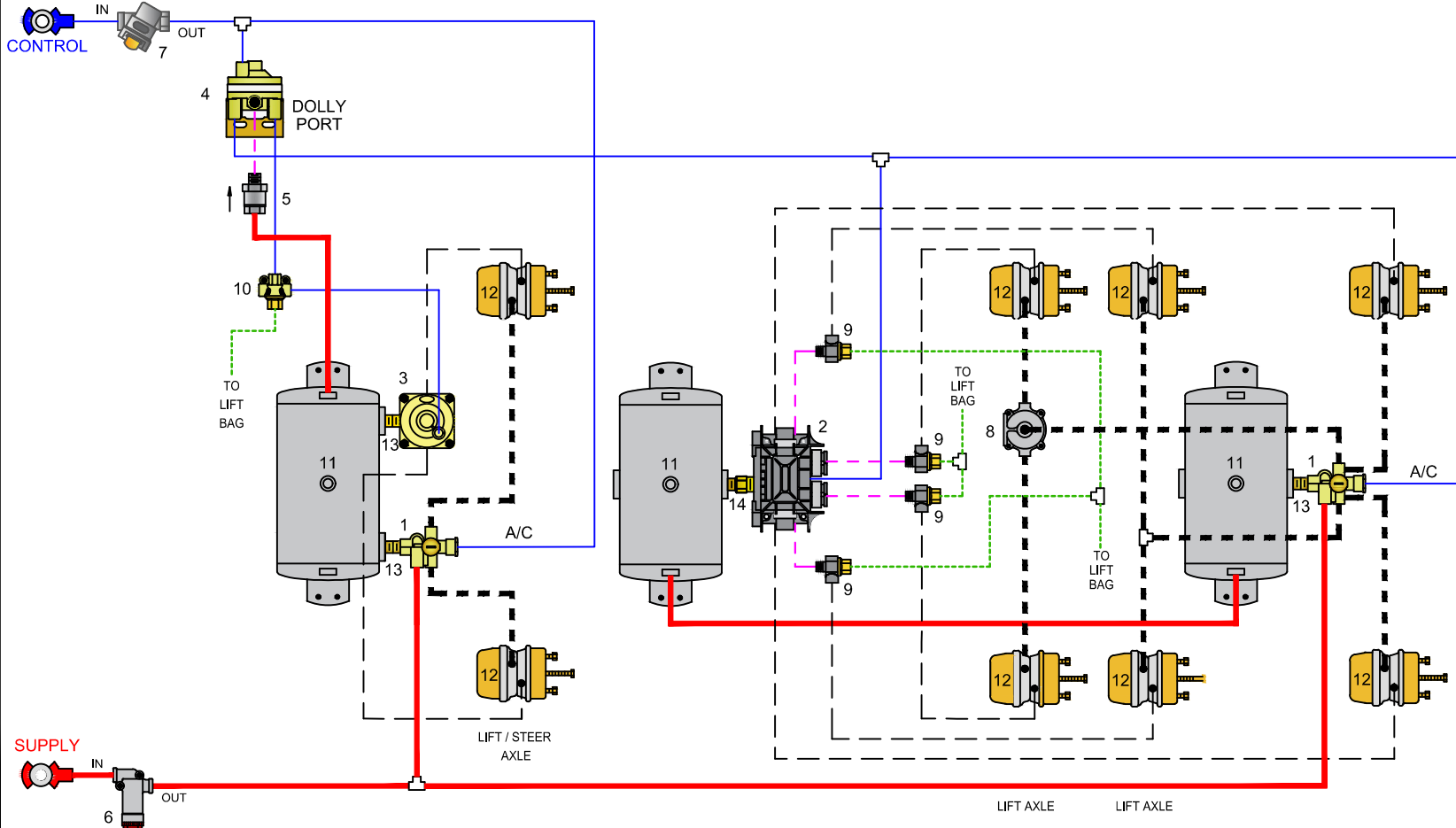

VEHICLE COMPLIANCE & CERTIFICATION WITH ALL APPLICABLE FEDERAL, STATE & PROVINCIAL REGULATIONS INCLUDING FMVSS 121 & CMVSS 121 IS SOLELY THE RESPONSIBILITY OF THE VEHICLE MANUFACTURER

AIR SYSTEM REQUESTED BY:

4 AXLE SEMI W/ 1 LIFT & STEER AXLE, 2 LIFT AXLES

DRAWN BY: MG	CHECKED: ZY	DATE: 3-22-2023	DRAWING NO: P-8088
-----------------	----------------	--------------------	-----------------------