

TEBS E

WIRING DIAGRAMS

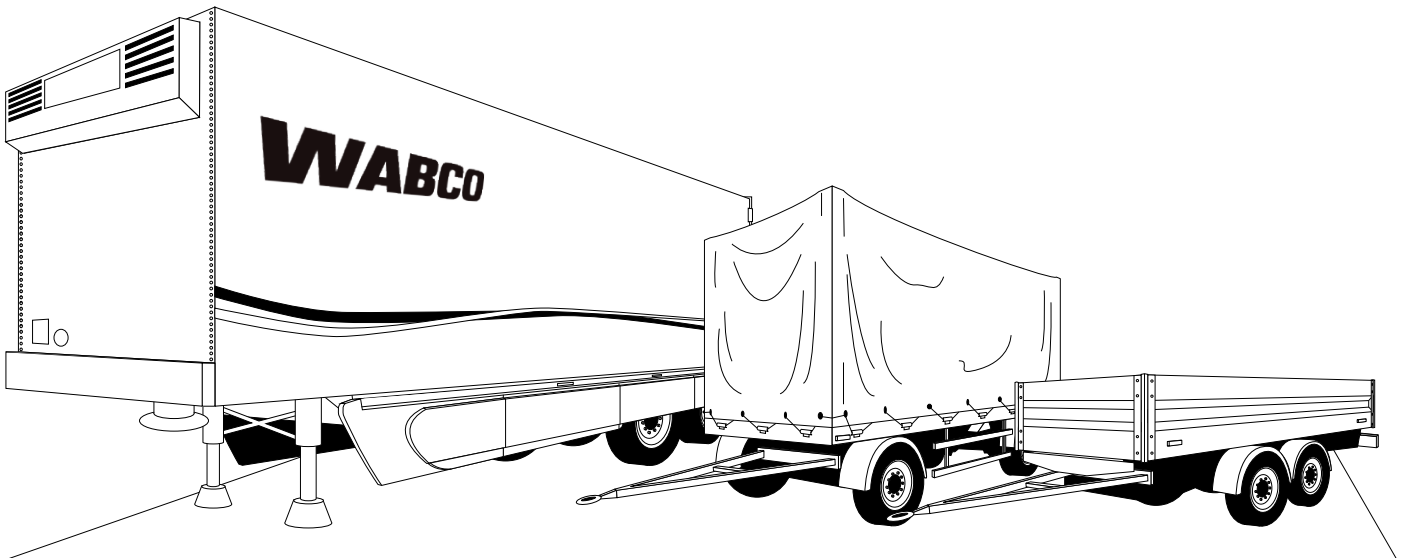

Table of Contents

1	General information	4
1	GIO schematic diagrams	6
2	Braking diagrams	69
2.1	Semitrailer	69
2.2	Central axle trailer	162
2.3	Drawbar trailer	189



1 General information

Copyright and trademark notice

The content, particularly technical information, descriptions and figures, corresponds to the state current at the time of printing and is subject to change without notice.

This document, including all its parts, in particular texts and figures, is protected by copyright. Use outside the statutory or contractual limits require authorisation by the copyright owner. All rights reserved.

Any brand names, even if not indicated as such, are subject to the rules of the trademark and labelling rights.

Technical documents



- Open the WABCO INFORM online product catalogue:
<http://inform.wabco-auto.com>
- Search for documents by entering the document number.

The WABCO online product catalogue INFORM provides you with convenient access to the complete technical documentation.

All documents are available in PDF format. Please contact your WABCO partner for printed versions.

Please note that the publications are not always available in all language versions.

DOCUMENT TITLE	DOCUMENT NUMBER
TEBS E Wiring Diagramms	815 XX0 233 3

*Language code XX: 01 = English, 02 = German, 03 = French, 04 = Spanish, 05 = Italian, 06 = Dutch, 07 = Swedish, 08 = Russian, 09 = Polish, 10 = Croatian, 11 = Romanian, 12 = Hungarian, 13 = Portuguese (Portugal), 14 = Turkish, 15 = Czech, 16 = Chinese, 17 = Korean, 18 = Japanese, 19 = Hebrew, 20 = Greek, 21 = Arabic, 24 = Danish, 25 = Lithuanian, 26 = Norwegian, 27 = Slovenian, 28 = Finnish, 29 = Estonian, 30 = Latvian, 31 = Bulgarian, 32 = Slovakian, 34 = Portuguese (Brazil), 35 = Macedonian, 36 = Albanian, 97 = German/English 98 = = multilingual, 99 = non-verbal

General information

Structure of the WABCO product number

WABCO product numbers consist of 10 digits.

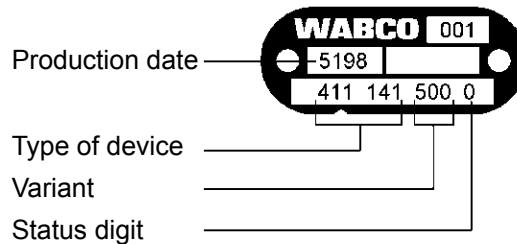

0 = New device (complete device); 1 = New device (subassembly);
2 = Repair kit or subassembly, 4 = Component part, 7 = Replacement device;
R = Reman

WABCO Service Partner

WABCO Service Partners – the network you can rely on. You can access 2000 high quality workshops with more than 6000 specialist mechanics, all trained to WABCO's exacting standards and equipped with our most up-to-the-minute systems diagnostic and support technology.

Your direct contact to WABCO

In addition to our online services, trained members of staff are there to help you at our WABCO Service Partners to directly answer any technical or business-related questions you may have.

Contact us if you need assistance:

- Find the right product
- Diagnosis support
- Training
- System support
- Order management



You can find your WABCO partner here:
<http://www.wabco-auto.com/en/how-to-find-us/contact/>

1 GIO schematic diagrams

NAME	LIFT AXLE(S)	SCHEMATIC DIAGRAM	VEHICLES	PAGE
Trailer EBS E – 4S/2M, 2S/2M with Immobilizer and pneumatic extension modul	–	841 701 227 0	Semitrailer	8
Trailer EBS E – Electronic parking brake and pneumatic extension modul	–	841 701 264 0	Semitrailer	9
ECAS – 2 height sensors with/without control box and unloading level switch for TEBS E (only available in German)	–	841 802 016 0	Drawbar trailer	10
ECAS-integrated 1 height sensor with SmartBoard, battery and charging current limitation for TEBS E (only in German available)	–	841 802 017 0	Drawbar trailer	11
2 Wegsensoren mit Bedieneinheit mit Akku für TEBS E (only in German available)	–	841 802 018 0	Drawbar trailer	12
2 Wegsensoren mit Bedienbox ohne Akku für TEBS E (only in German available)	–	841 802 019 0	Drawbar trailer	13
Trailer EBS E – Air suspension with levelling valve and one-circuit lift axle valve	1	841 802 150 0	Semitrailer	14
Trailer EBS E – Air suspension with levelling valve and one-circuit lift axle valve	2	841 802 151 0	Semitrailer	15
Trailer EBS E – Air Suspension with levelling valve and one-circuit lift axle valve	1	841 802 152 0	Semitrailer	16
Trailer EBS E – Mechanical suspension	–	841 802 153 0	Semitrailer	17
Trailer EBS E – Mechanical suspension	–	841 802 154 0	Drawbar trailer	18
Trailer EBS E – Air Suspension with levelling valve and one-circuit lift axle valve	2	841 802 155 0	Semitrailer	19
Trailer EBS E – Air Suspension with levelling valve and 2x TASC	–	841 802 156 0	Drawbar trailer	20
Trailer EBS E – ECAS with Traction Help, ECAS lifting and lowering, 1-point-control and 2 lift axles	2	841 802 157 0	Semitrailer	21
Trailer EBS E – Air suspension, ECAS lifting and lowering, 1-point-control + 2 lift axles	2	841 802 158 0	Semitrailer	22
Trailer EBS E – Air suspension (TASC - RtR function)	–	841 802 159 0	Semitrailer	23
Trailer EBS E – Air suspension, ECAS lifting and lowering, 1-point-control and 1 lift axle	1	841 802 190 0	Semitrailer	24
Trailer EBS E – Air suspension, ECAS lifting and lowering, 1-point-control and 1 lift axle and maintain residual pressure	1	841 802 191 0	Semitrailer	25
Trailer EBS E – Air suspension, ECAS lifting and lowering, 1-point-control and 1 lift axle	1	841 802 192 0	Semitrailer	26
Trailer EBS E – Air suspension with levelling valve and one-circuit lift axle valve	1	841 802 193 0	Semitrailer	27
Trailer EBS E – Air suspension, ECAS lifting and lowering, 1-point-control and 2 lift axles	2	841 802 194 0	Semitrailer	28
Trailer EBS E – Air suspension (2 circuit), ECAS lifting and lowering, 1-point-control and 2 lift axles	2	841 802 195 0	Semitrailer	29
Trailer EBS E – Air suspension, ECAS lifting and lowering, 1-point-control and 2 lift axles	2	841 802 196 0	Semitrailer	30
Trailer EBS E – Air suspension, 4S/3M lift axle and steering axle (Road tankers)	1	841 802 197 0	Semitrailer	31
Trailer EBS E – Air suspension with trailer EBS E1, ECAS lifting and lowering, 1-point-control and 2 lift axles (Road finisher brake)	2	841 802 198 0	Semitrailer	32
Trailer EBS E – Air suspension with TEBS E1, 2S/2M, ECAS lifting and lowering, 1-point-control, 2 lift axles (only in German available)	2	841 802 199 0	Semitrailer	33
Trailer EBS E Premium – 4S/3M, ECAS lifting and lowering, OptiTurn™/OptiLoad™, with ECAS, traction help, lift axle on axle 1, tag axle on axle 3, SmartBoard (only in German available)	1	841 802 235 0	Semitrailer	34
Trailer EBS E1 Premium – 4S/3M, ECAS lifting and lowering, OptiTurn™ and OptiLoad™, green warning lamp, lift axle on axle 1, dragging axle on axle 3, SmartBoard	1-2	841 802 236 0	Semitrailer	35
Trailer EBS E – Air suspension with levelling valve and 1-circuit lift axle valve	1	841 802 237 0	Semitrailer	36

GIO schematic diagrams

NAME	LIFT AXLE(S)	SCHEMATIC DIAGRAM	VEHICLES	PAGE
Trailer EBS E – Lifting and lowering RTR, 1st axle lifting axle, traction help 3rd axle, wheelbase control with manoeuvring assistance and residual pressure maintenance, SmartBoard (only in German available)	1	841 802 238 0	Semitrailer	37
Trailer EBS E – Air suspension, 4S/2M, 2-axles with 2 lift axles (for forklift control)	2	841 802 239 0	Central axle trailer	38
Trailer EBS E – Air suspension, 4S/3M, LACV-IC, dragging axle, SmartBoard	–	841 802 240 0	Semitrailer	39
Trailer EBS E – Air suspension, 4S/3M, OptiTurn™ and OptiLoad™ with LACV-IC, lift axle, SmartBoard	1	841 802 241 0	Semitrailer	40
Trailer EBS E – Air suspension, 4S/3M, OptiTurn™ and OptiLoad™ mit ECAS lifting and lowering, 1-point-control, 1 lift axle, SmartBoard	1	841 802 243 0	Semitrailer	41
ECAS-integrated, 1 height sensor with NLL control and road finisher brake function for TEBS E (only in German available)	–	841 802 244 0	Semitrailer	42
ECAS 2-point regulation for glas inloader, vehicle with independent suspension	2	841 802 250 0	Semitrailer	43
ECAS 2-point regulation with electronic extension module, ECAS add-on valve on 1st axle	–	841 802 252 0	Drawbar trailer	44
ECAS-integrated, 1 height sensor with 1 axle lifting axle, 3rd axle lifting axle, operation via SmartBoard or control box (traction help) (only in German available)	2	841 802 271 0	Semitrailer	45
Trailer EBS E1 Premium – Air Suspension, 4S/3M, OptiTurn™ and OptiLoad™ with LACV-IC, lift axle, SmartBoard	1	841 802 272 0	Semitrailer	46
Trailer EBS E – Trailer safety brake (Safe Start) and ECAS	–	841 802 274 0	Semitrailer Dumper, Tanker, Roll-off container	47
TailGUARDlight™	–	841 802 280 0	All trailer vehicles	48
TailGUARD™ with 3 sensors	–	841 802 281 0	All trailer vehicles	49
TailGUARDMAX™ with 6 sensors	–	841 802 282 0	All trailer vehicles	50
TailGUARD ^{Roof} ™ with 5 sensors	–	841 802 283 0	All trailer vehicles	51
TailGUARD ^{Roof} ™ (from version TEBS E2.5) with 5 sensors (only in German available)	–	841 802 284 0	All trailer vehicles	52
TailGUARD™ with 3 sensors with electronic extension module update and Trailer EBS E2.5	–	841 802 285 0	All trailer vehicles	53
Trailer EBS E – for extendable or telescopic trailer	–	841 802 290 0	Semitrailer Drawbar trailer	54
Trailer EBS E – emergency stop light function	1	841 802 291 0	All trailer vehicles	55
Trailer EBS E – Conventional air suspension, lift axle on axle 1, with forklifter control	1	841 802 292 0	Central axle trailer	56
Trailer EBS E – 2-circuit without lift axle	–	841 802 295 0	Semitrailer	57
Trailer EBS E – 2-circuit with lift axle	1	841 802 296 0	Semitrailer	58
Trailer EBS E – 2-circuit, lift axle 1 and 3	2	841 802 297 0	Semitrailer	59
Trailer EBS E – ECAS lifting and lowering	–	841 802 299 0	Semitrailer	60
Trailer EBS E Premium – 4S/3M, OptiTurn™ and OptiLoad™ with eTASC and LACV-IC	1-2	841 802 321 0	Semitrailer	61
Trailer EBS E – Air suspension with 2x eTASC	–	841 802 322 0	Drawbar trailer	62
Trailer EBS E – Air suspension with lift axle and eTASC	1	841 802 325 0	Drawbar trailer	63
Trailer EBS E – Air suspension with 2x eTASC and lift axle	1	841 802 327 0	Drawbar trailer	64
ECAS 2-point regulation (without electronic extension module) (up from E4)	–	841 802 329 0	Drawbar trailer	65
ECAS 2-point regulation (without electronic extension module, with lift axle control) (up from E4)	1	841 802 351 0	Drawbar trailer	66
ECAS 2-point regulation without electronic extension module, Premium up from E4, ECAS Add-On valve on 1st axle	–	841 802 352 0	Drawbar trailer	67
ECAS 2-point regulation without electronic extension module, Premium up from E4, ECAS Add-On valve on 1st axle	–	841 802 353 0	Drawbar trailer	68

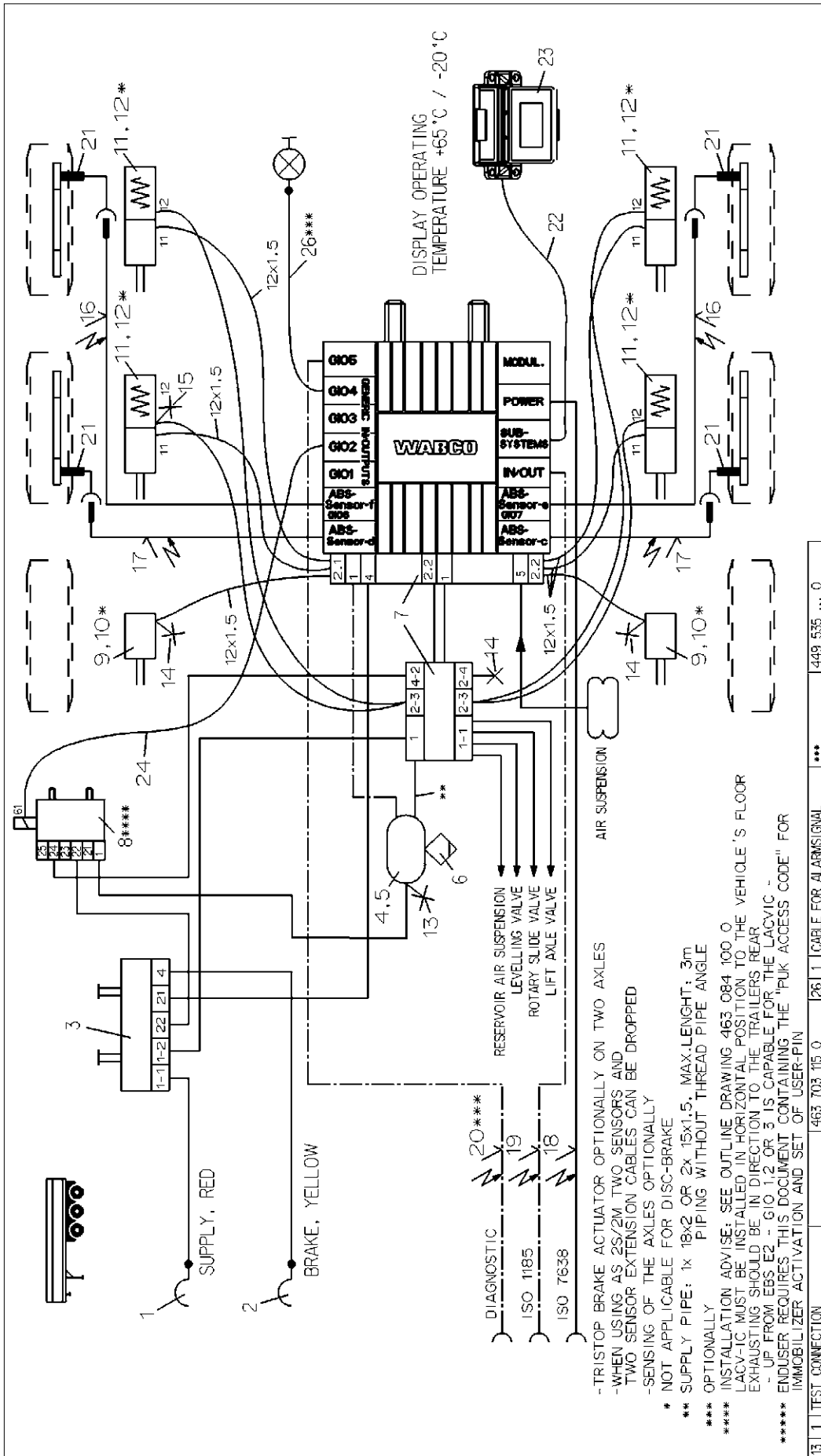

13	1 TEST CONNECTION	463 703 115 0	26	1 CABLE FOR ALARMSIGNAL	***	449 535 ... 0
12	4 KIT	423 903 532 2	25	1 PUK ACCESS CODE	*****	813 000 049 3
11	4 TRISTOP BRAKE ACTUATOR	925 ... 0	24	1 CABLE LACV-IC		449 445 ... 0
10	2 KIT	423 000 ... 2	23	1 SMART BOARD		446 192 11 0
9	2 BRAKE CHAMBER	423 10 ... 0	22	1 CABLE-SMART BOARD		449 911 ... 0
8	1 LACV-IC	463 084 100 0	21	4 ABS-SENSOR	***	441 032 8... 0
7	1 TRAILER-MODULATOR W. PNEU. EXTEN. MODUL	480 102 ... 0	20	1 DIAGNOSTIC CABLE		449 611 ... 0
6	1 DRAIN VALVE	934 300 001 0	19	1 24N-CABLE		449 349 ... 0
5	2 HOSE CLAMP	451 999 ... 2	18	1 SUPPLY (POWER) CABLE		449 173 ... 0
4	1 AIR RESERVOIR	950 ... 0	17	2 EXTENSION CABLE FOR SENSOR		449 723 ... 0
3	1 PARK-RELEASE-EMERG.-VALVE (PREV)	971 002 9... 0	16	2 EXTENSION CABLE FOR SENSOR		449 723 ... 0
2	1 COUPLING HEAD W. INT. LINE FILTER	952 201 001 0	15	1 TEST CONNECTION		463 703 036 0
1	1 COUPLING HEAD W. INT. LINE FILTER	952 201 002 0	14	3 TEST CONNECTION		463 703 120 0

Part No.	Denomination	Pos./Pcs.	Product Identification No.
A 3	Pro/E	E	4990
ESR No.	Rev. 200	Rev. 200	123716
Part No.	Denomination	Pos./Pcs.	Product Identification No.
841 701 227 0	TRAILER - EBS E	E	4990
002	EN	1/1	

WABCO	
Part No.	Signature
2009-11-10	BURMESTER
2009-11-10	LANGOWICZ
Part No.	Scale
BURMESTER	
Rev. 2	
Part No.	Scale
841 701 227 0	
ESR No.	Rev. 200
A 3	E
ESR No.	Rev. 200
123716	E
Part No.	Denomination
841 701 227 0	TRAILER - EBS E
002	EN
1/1	1/1

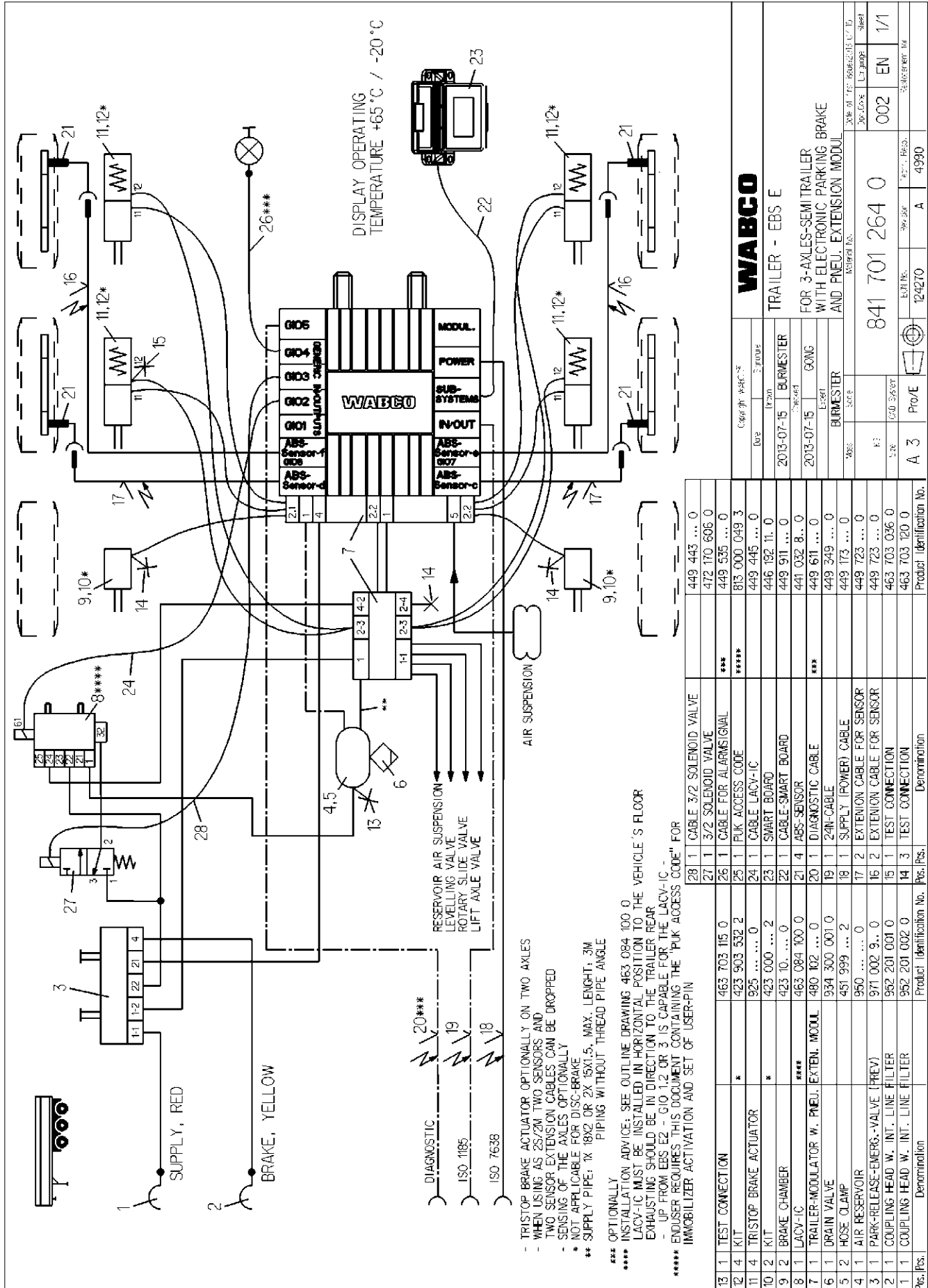

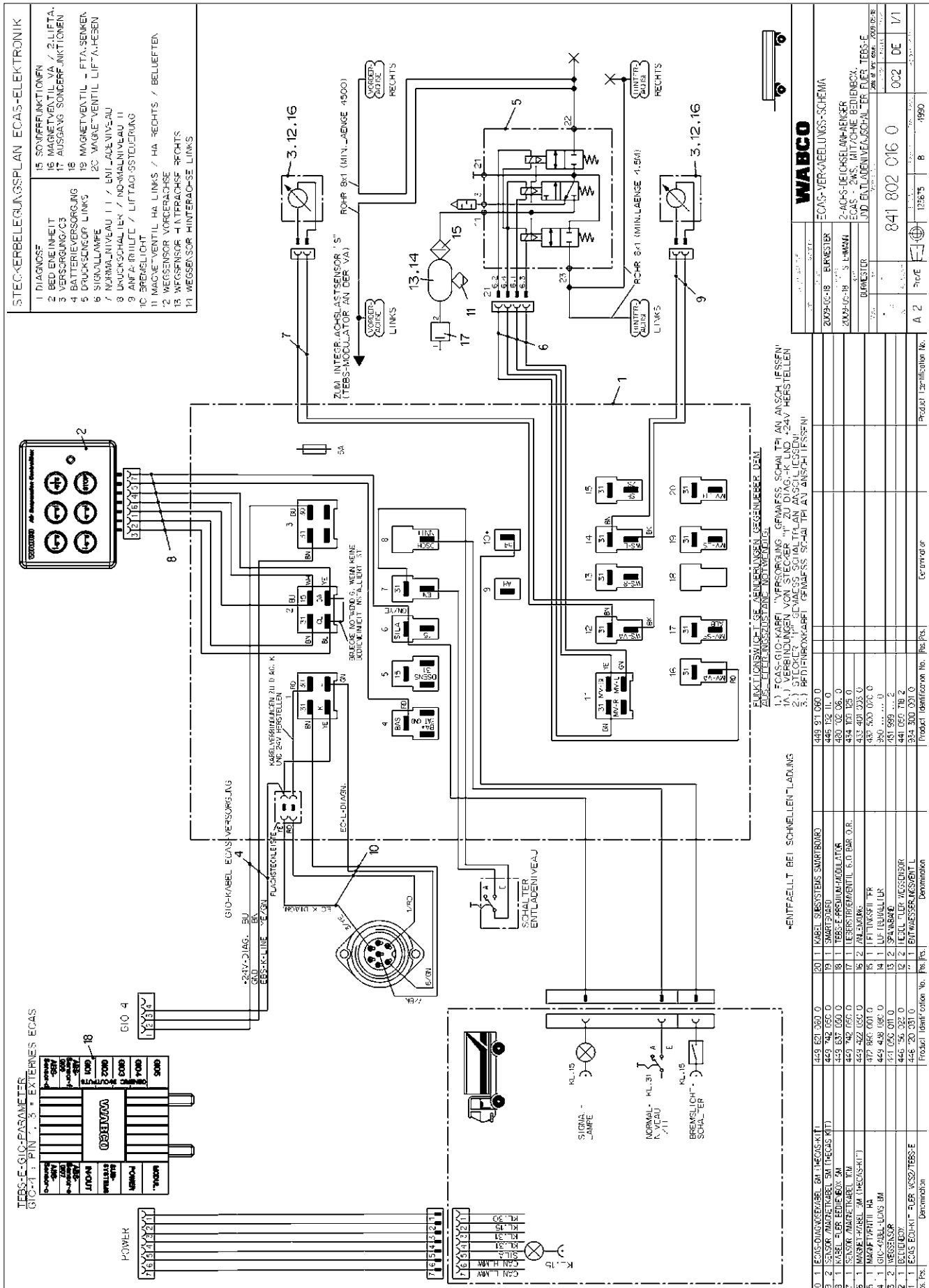

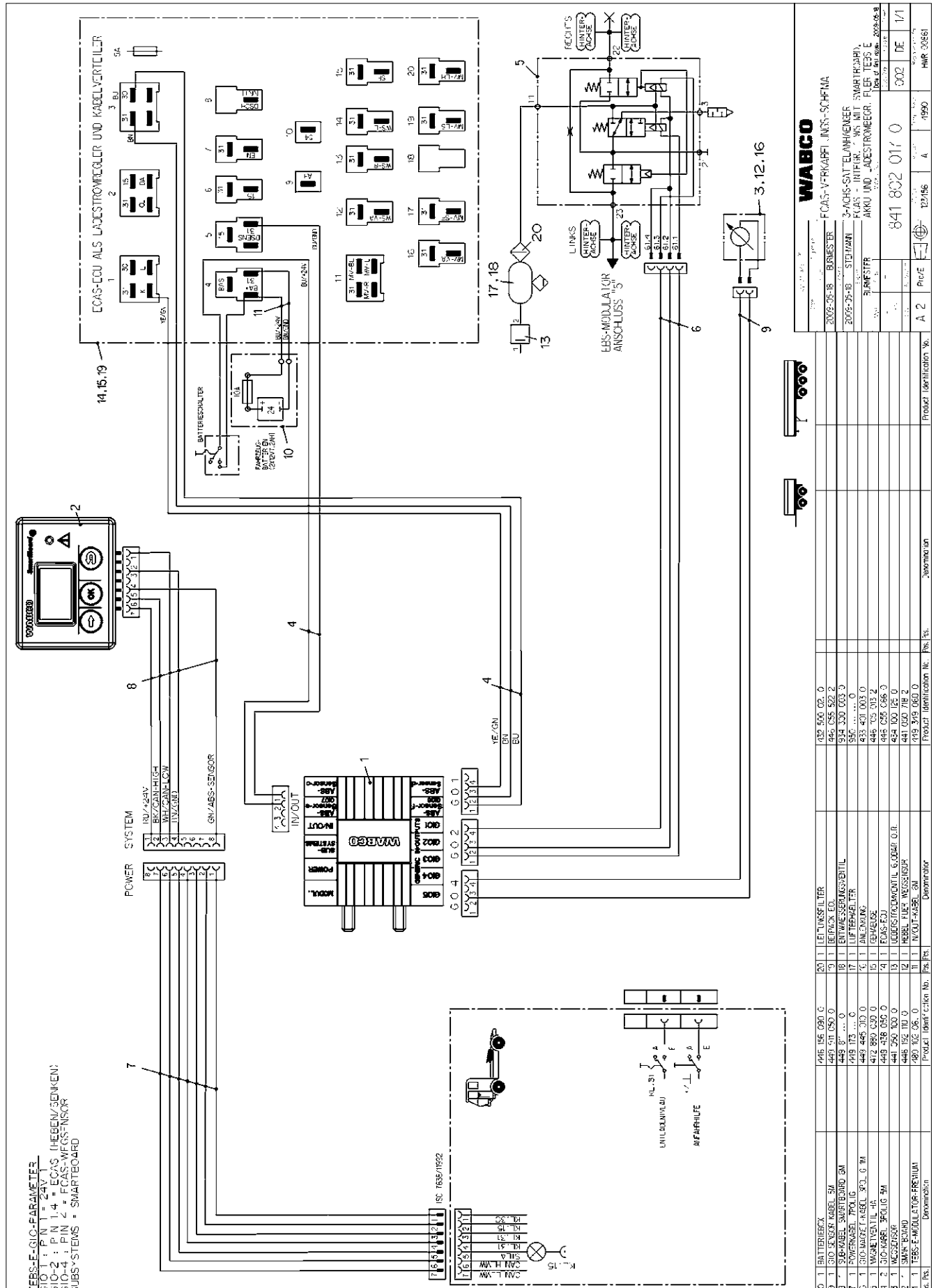

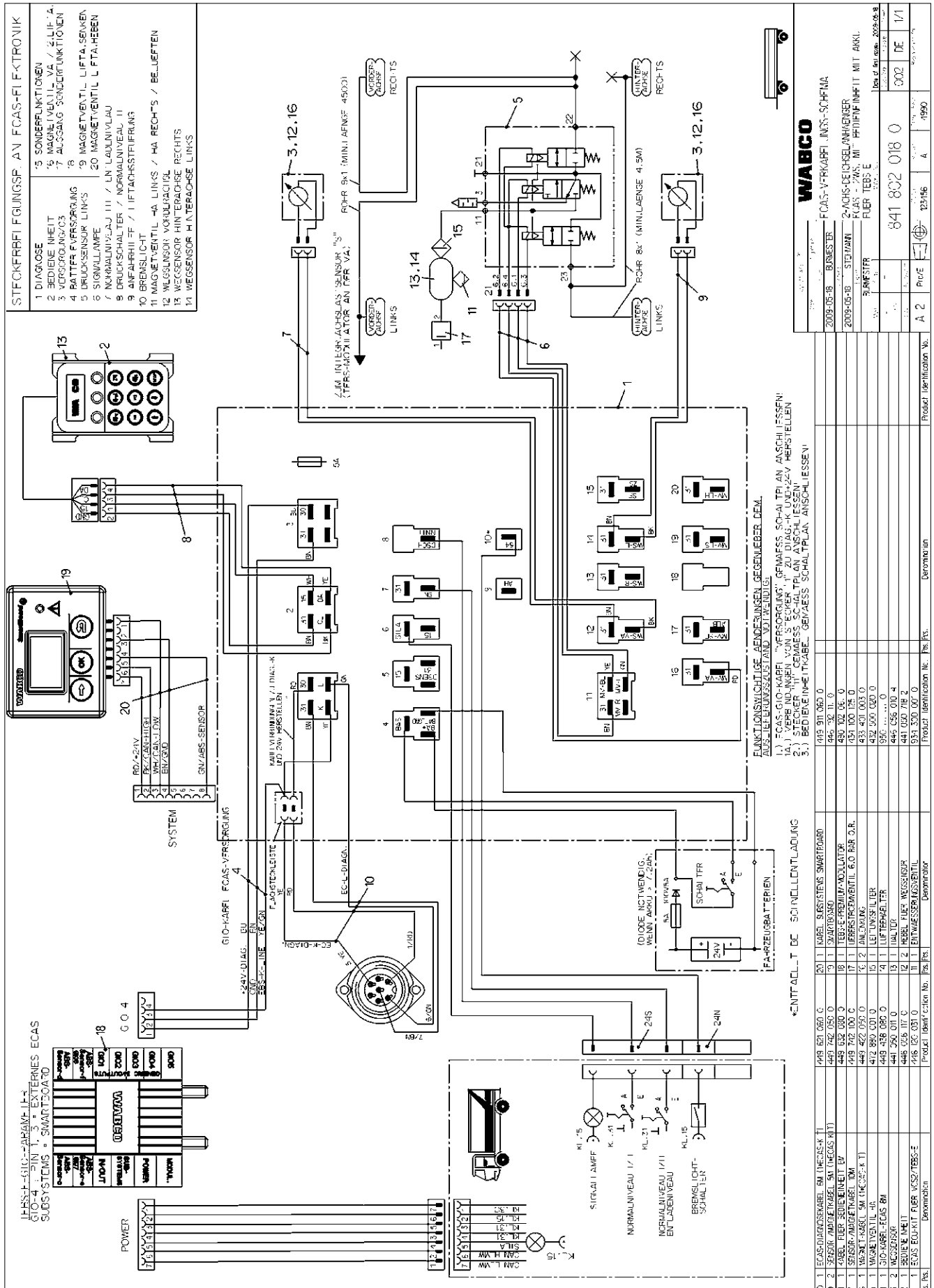

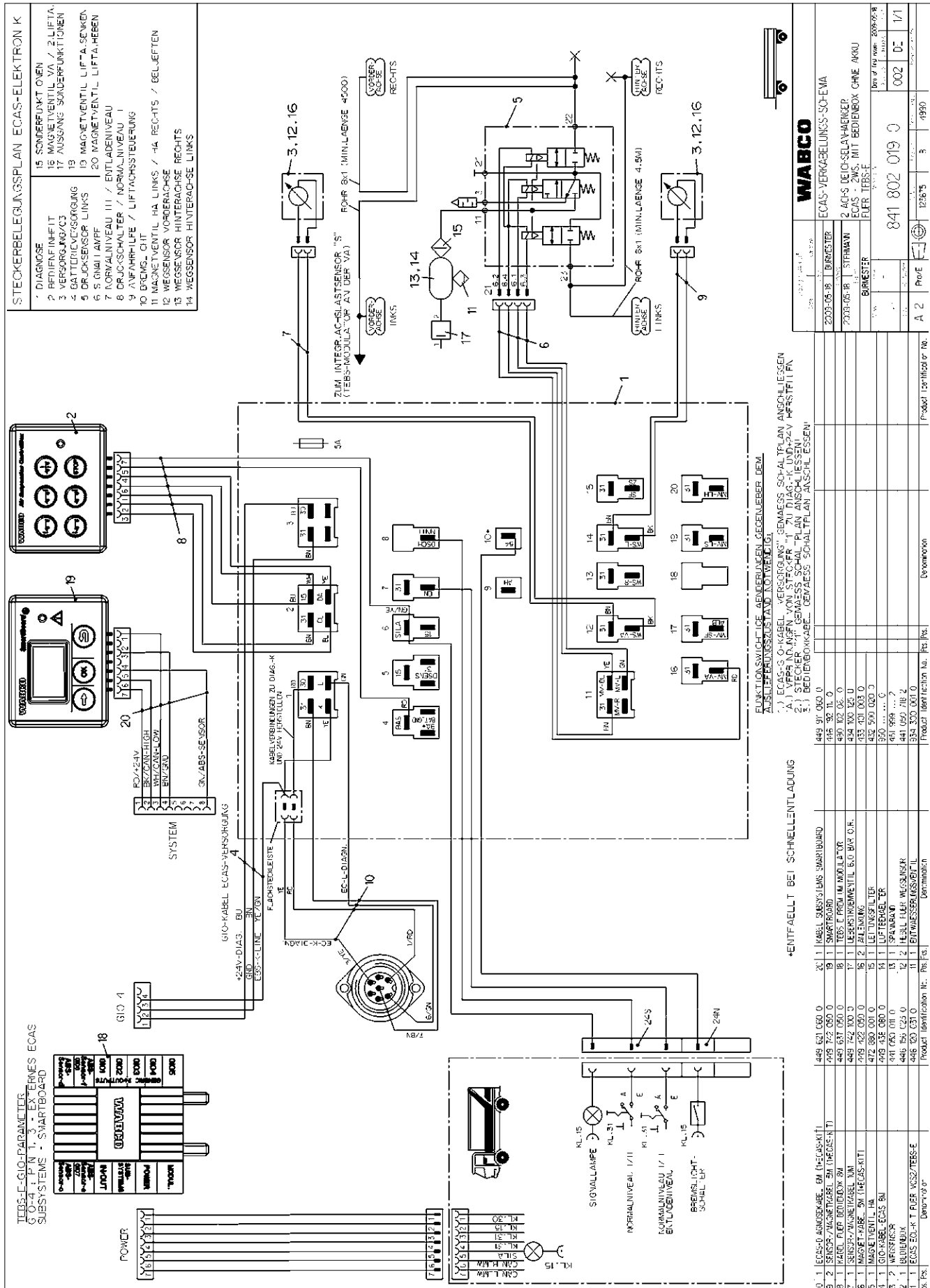

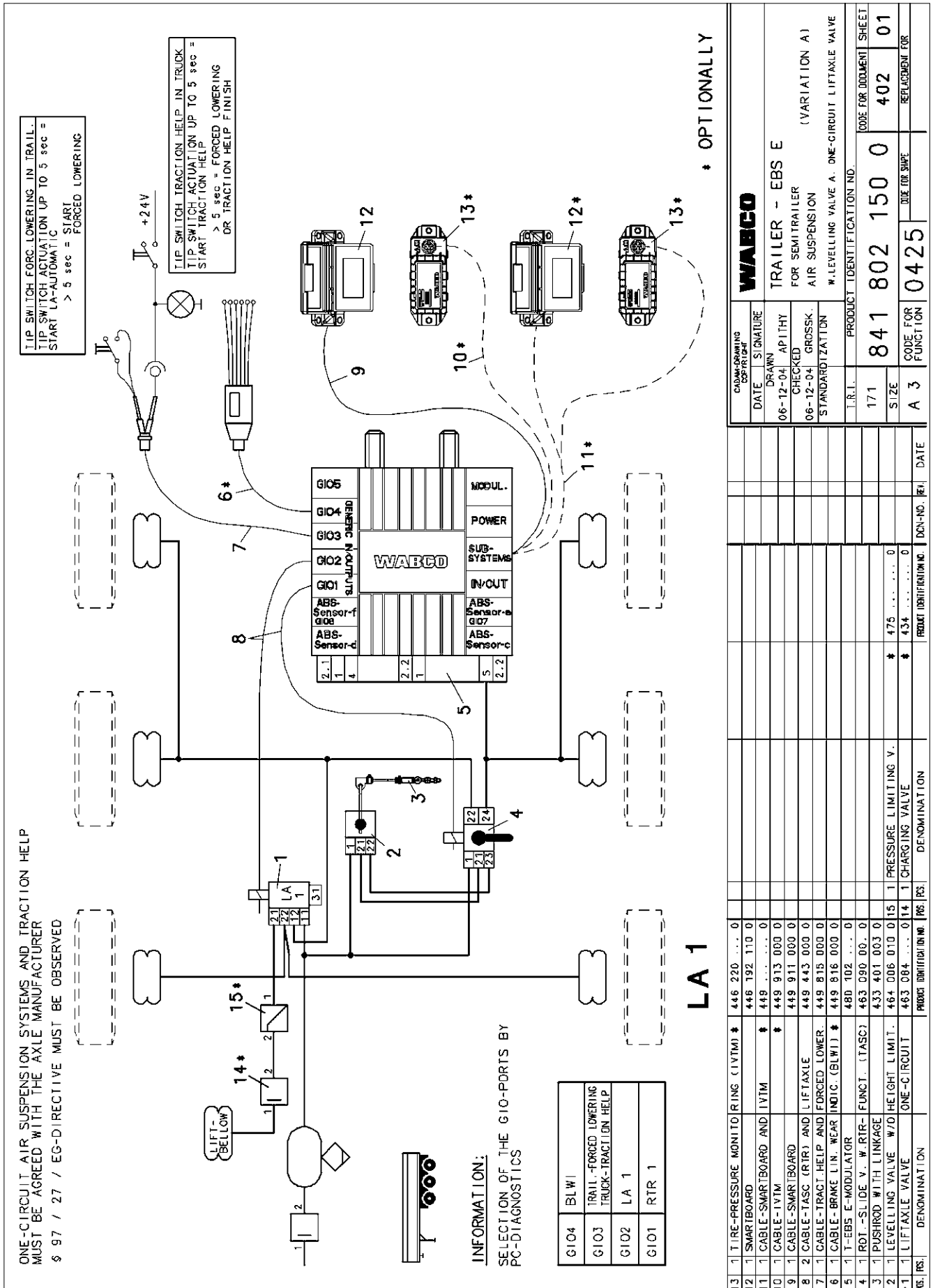

CHK	DATE	DRAWN	WABCO		
	SIGNATURE	CHECKED	TRAILER - EBS E		
		STANDARDIZATION	FOR SEMITRAILER AIR SUSPENSION (VARIATION A)		
			W.LEVELLING VALVE A. ONE-CIRCUIT LIFTAXLE VALVE		
PRODUCT IDENTIFICATION NO.					
171		841 802 150 0		CODE FOR DOCUMENT SHEET	
A 3		0425		402 01	
				REPLACEMENT FOR	
DENOMINATION		PRODUCT IDENTIFICATION NO.		DATE	
§ 97 / 27 / EG-DIRECTIVE MUST BE OBSERVED		TRAILER IDENTIFICATION NO.		475 000 000	
TRAILER IDENTIFICATION NO.		PRODUCT IDENTIFICATION NO.		434 000 000	
TRAILER IDENTIFICATION NO.		PRODUCT IDENTIFICATION NO.		434 000 000	
TRAILER IDENTIFICATION NO.		PRODUCT IDENTIFICATION NO.		434 000 000	
TRAILER IDENTIFICATION NO.		PRODUCT IDENTIFICATION NO.		434 000 000	

* OPTIONALY

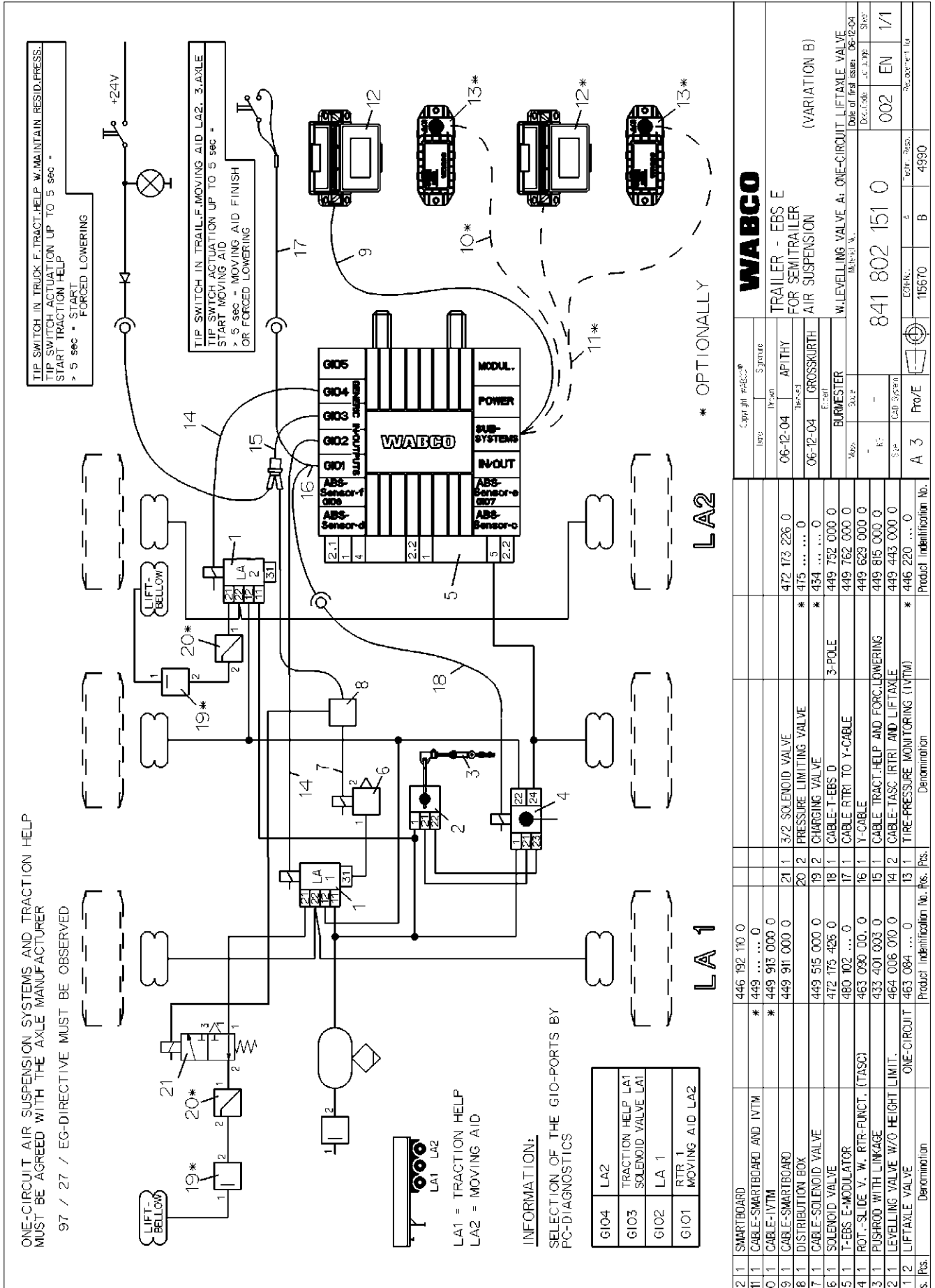

12 1	SMARTBOARD	446 192 110 0																				
11 1	CABLE-SMARTBOARD AND IVTM	* 449 0																				
10 1	CABLE-IVTM	* 449 913 000 0																				
9 1	CABLE-SMARTBOARD	449 911 000 0	21 1	3/2 SOLENOID VALVE	472 173 226 0																	
8 1	DISTRIBUTION BOX		20 2	PRESSURE LIMITING VALVE	* 475 0																	
7 1	CABLE-SOLENOID VALVE	449 515 000 0	19 2	CHARGING VALVE	* 434 0																	
6 1	SOLENOID VALVE	472 175 426 0	18 1	CABLE-T-EBS D	449 752 000 0																	
5 1	T-EBS E-MODULATOR	480 102 ... 0	17 1	CABLE RTR1 TO Y-CABLE	449 762 000 0																	
4 1	ROT.-SLIDE V. W. RTR-FUNCT. (TASC)	463 090 00... 0	16 1	Y-CABLE	449 628 000 0																	
3 1	PUSHROD WITH LINKAGE	433 401 003 0	15 1	CABLE TRACT-HELP AND FORC. LOWERING	449 815 000 0																	
2 1	LEVELLING VALVE W/O HEIGHT LIMIT.	464 006 010 0	14 2	CABLE-TASC RTR1 AND LIFTAXLE	449 443 000 0																	
1 2	LIFTAXLE VALVE	463 084 ... 0	13 1	TIRE-PRESSURE MONITORING (IVTM)	* 446 220 ... 0																	
bs. Pcs.	Denomination		Product Identification No. Pcs.	Denomination																		

WABCO

TRAILER - EBS E
 FOR SEMITRAILER
 AIR SUSPENSION
 (VARIATION B)

W/LEVELLING VALVE A: ONE-CIRCUIT LIFTAXLE VALVE
 Model No.

Date of first issue: 06-12-04
 Doc. Code: 41-A.002 5103

Model No. 841 802 151 0
 EN 1/1
 EDRN. 115570 B 4990
 Pro/E A 3

LA2

LA1

* OPTIONALLY

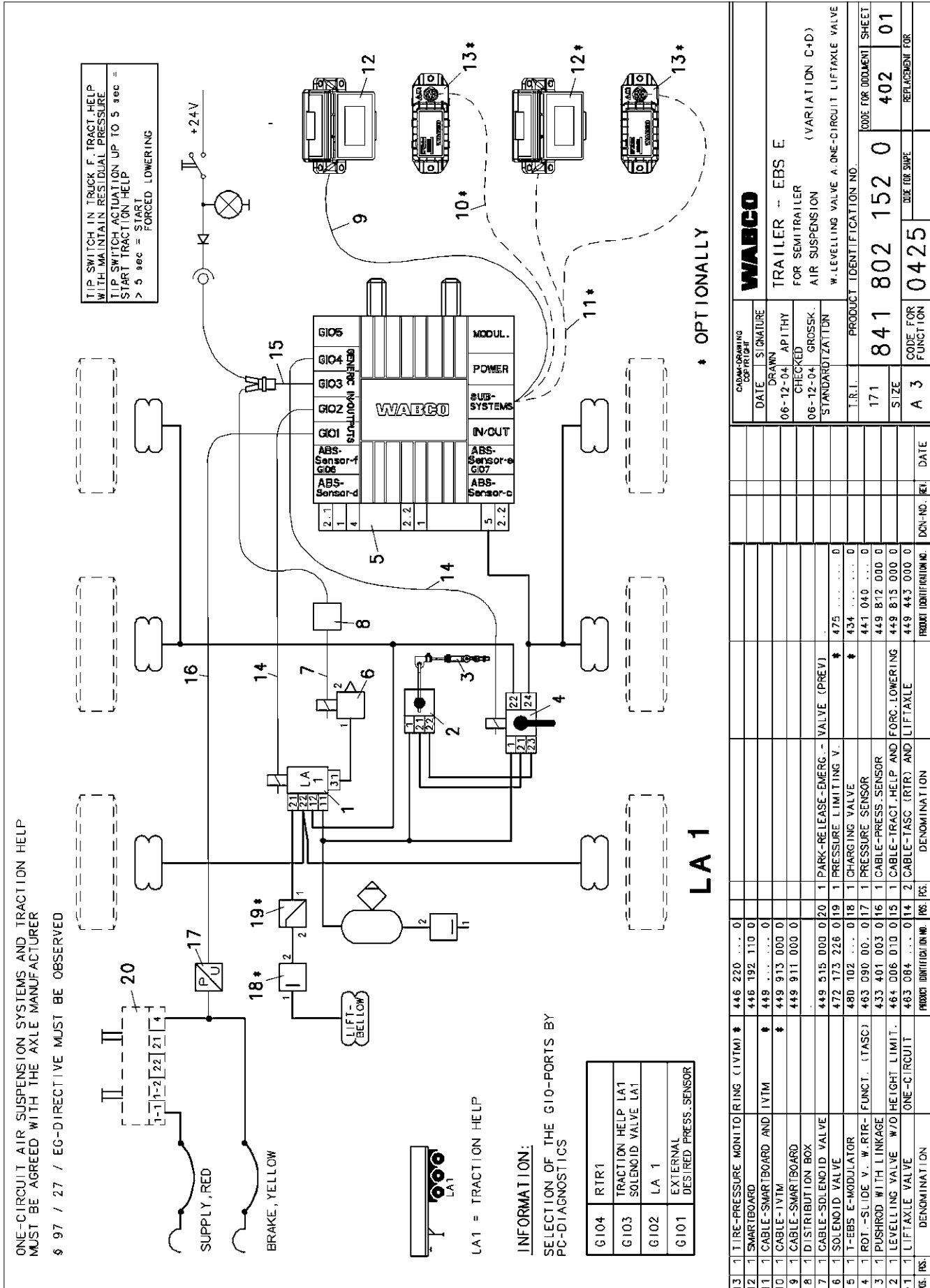

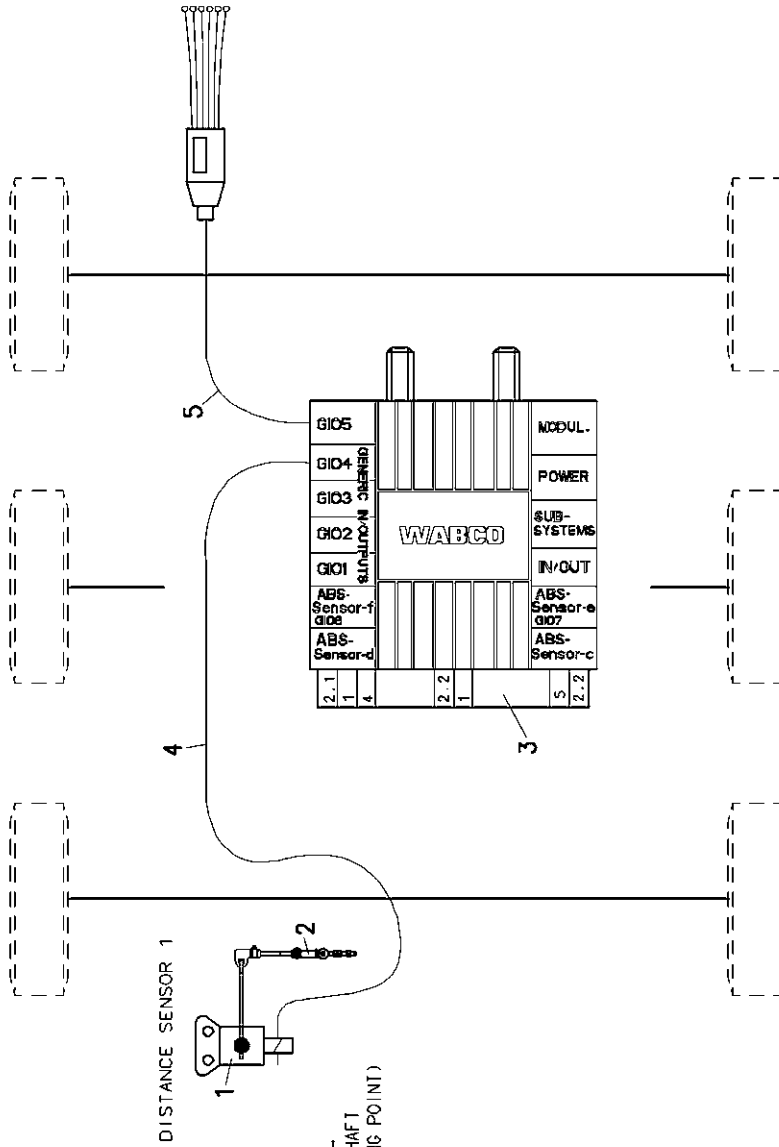

DISTANCE SENSOR 1

INSTALL DIST. SENSOR DIRECTLY INTO THE DS'S SHAFT (HOLE 100 mm OF THE TURNING POINT)

INFORMATION:
SELECTION OF THE GIO-PORTS BY PC-DIAGNOSTICS

G105	BLW1
G104	DIST.-SENSOR 1
G103	—
G102	—
G101	—

DRAWING DATE		SIGNATURE		WABCO	
DRAWN		APPROVED		TRAILER - EBS E	
CHECKED		GROSSK		FOR SEMI TRAILER	
STANDARDIZATION		MECH. SUSPENSION		(VARIATION E)	
I.T.L.		PRODUCT IDENTIFICATION NO.		CODE FOR DOCUMENT SHEET	
171		841 802 153 0		402 01	
SIZE		CODE FOR FUNCTION		REPLACEMENT FOR	
A 3		0425			
DCN-NO.		DCN-NO.		DATE	
111998 A		07-01-05			
PROJECT IDENTIFICATION		DENOMINATION		RS. PCS.	
449 816 000 0		CABLE-BRAKE LIN. WEAR INDIC. (BLW1)		5 1	
449 811 000 0		CABLE-DIST. SENSOR		4 1	
480 102 ... 0		EBS E-MODULATOR		3 1	
441 050 71. 2		PUSHROD WITH LINKAGE		2 1	
441 050 100 0		DISTANCE SENSOR 1		1 1	

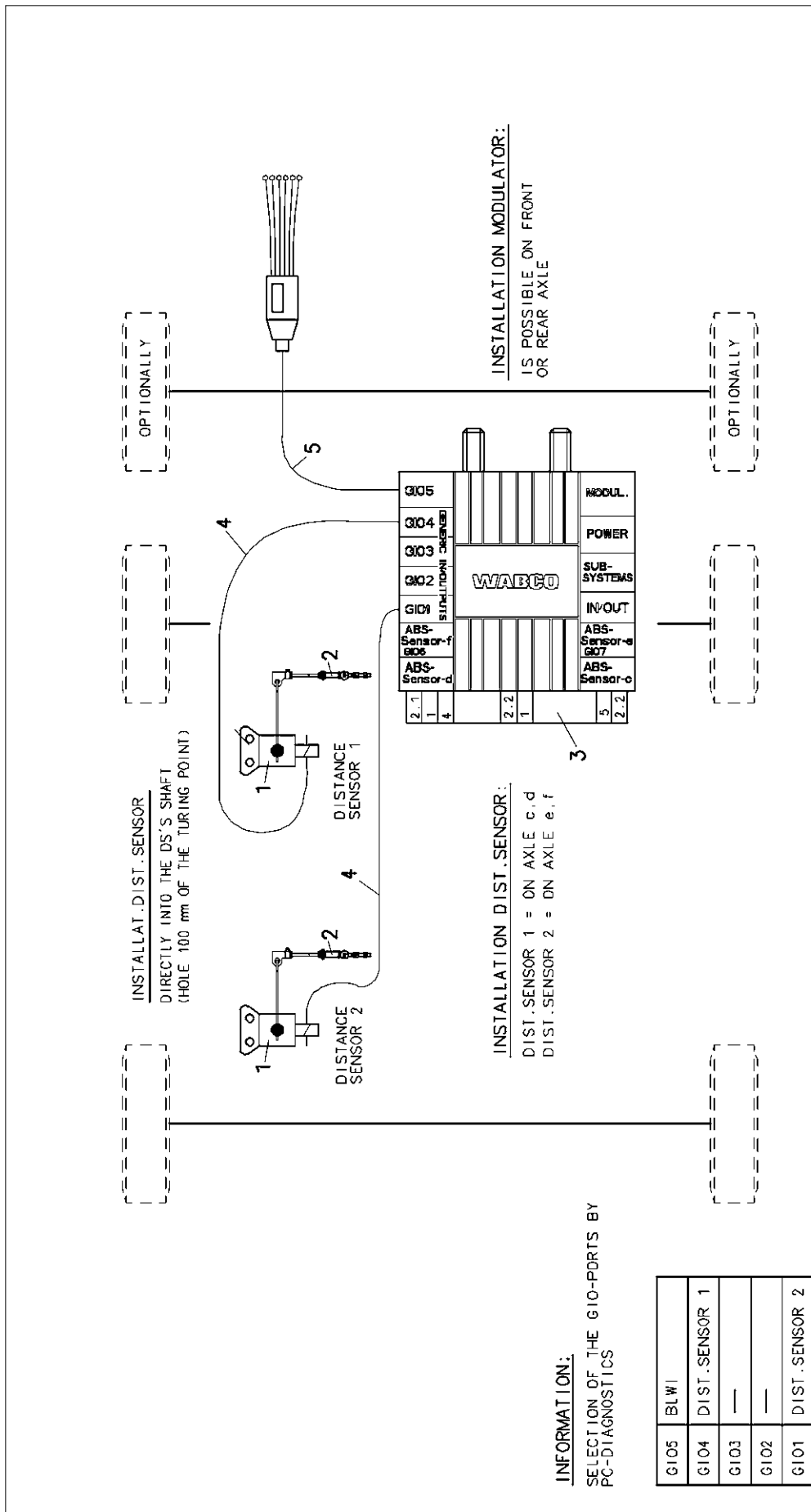

Cable Drawing Control		WABCO	
DATE	SIGNATURE	TRAILER – EBS E FOR TRAILER (2 OR 3 AXLES) MECH. SUSPENSION (VARIATION F)	CODE FOR DOCUMENT SHEET
06-12-04	API THY		402 01
CHECKED 06-12-04 GROSSK STANDARDIZATION			REPLACEMENT FOR
T.R.T. PRODUCT IDENTIFICATION NO.		841 802 154 0	
171	SIZE	CODE FOR FUNCTION	0425
112193 B 07-01-23	DATE	DDC FOR SWPE	
111998 A 07-01-05	DSN-NO. (EE)		
PRODUCT IDENTIFICATION NO.	RS.	RS.	RS.
449 816 000 0			
449 811 000 0			
480 102 ... 0			
441 050 711 -2			
441 050 100 0			
INDIC. (BLWI)	DENOMINATION	DENOMINATION	DENOMINATION
1 CABLE - BRAKE LIN. WEAR			
2 CABLE-DIST. SENSOR			
1 T-EBS E-MODULATOR			
2 PUSHRD WITH LINKAGE			
1 2 DISTANCE SENSOR			

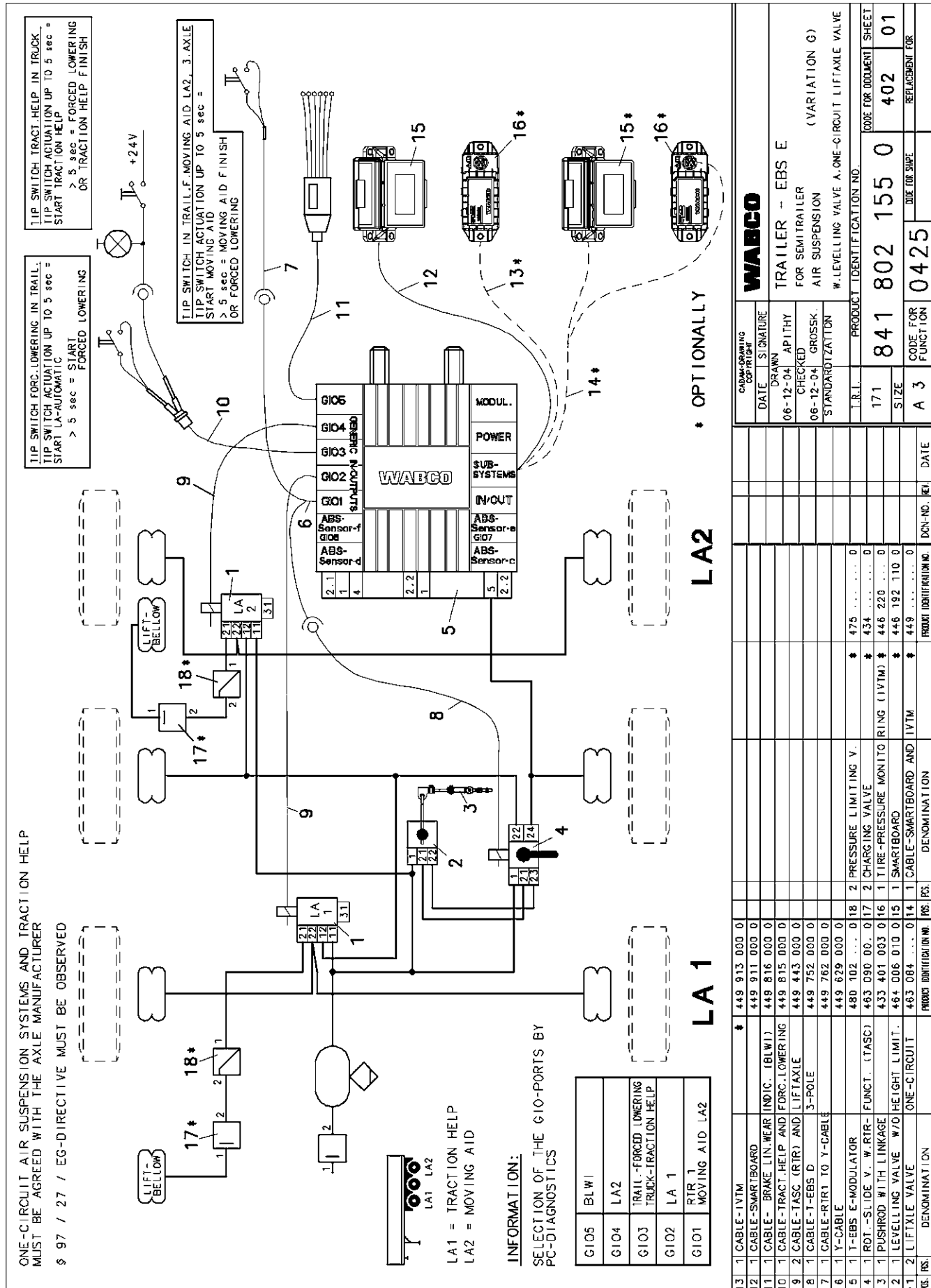

ONE-CIRCUIT AIR SUSPENSION SYSTEMS AND TRACTION HELP
MUST BE AGREED WITH THE AXLE MANUFACTURER
§ 97 / 27 / EG-DIRECTIVE MUST BE OBSERVED

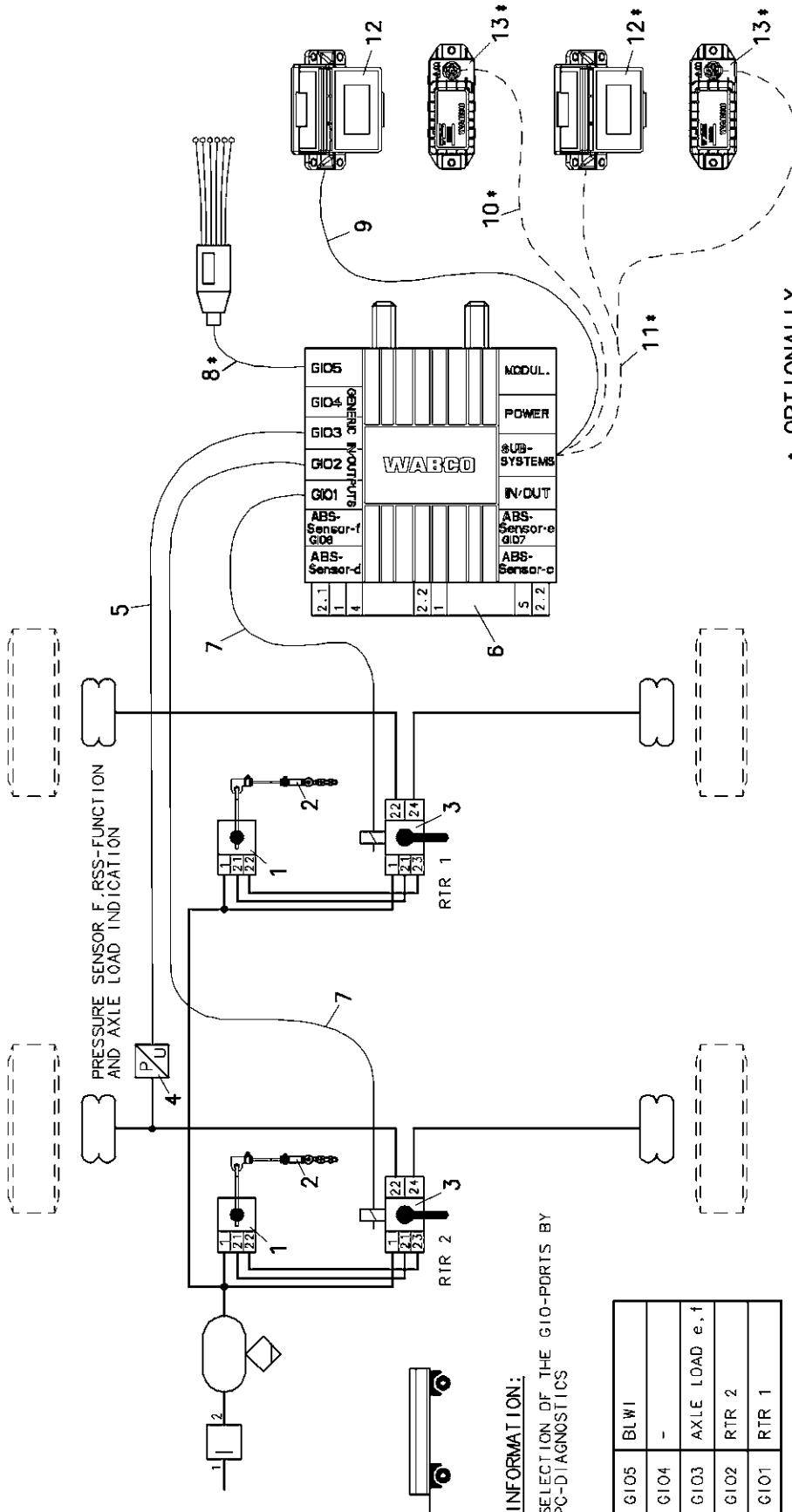

INFORMATION:
SELECTION OF THE GIO-PORTS BY
PC-DIAGNOSTICS

GIO	BLWI
GIO5	-
GIO4	-
GIO3	AXLE LOAD e.f.t
GIO2	RTR 2
GIO1	RTR 1

* OPTIONAL

13	1	TIRE-PRESSURE MONITORING (VTM) *	446 220 ... 0																			
12	1	SMARTBOARD *	446 192 110 0																			
11	1	CABLE-SMARTBOARD AND IVTM *	449 ... 0																			
10	1	CABLE-IVTM *	449 913 000 0																			
9	1	CABLE-SMARTBOARD	449 911 000 0																			
8	1	CABLE-BRAKE LIN. WEAR INDIC. (BLWI) *	449 816 000 0																			
7	2	CABLE-TASC (RTR)	...																			
6	1	T-EBS E-MODULATOR	480 102 ... 0																			
5	1	CABLE TO PRESS. SENS.	449 812 000 0																			
4	1	PRESSURE SENSOR	441 040 ... 0																			
3	2	ROT.-SLIDE V. W. RTR- FUNCT. (TASC)	463 080 00. 0																			
2	2	PUSHROD WITH LINKAGE	433 401 003 0																			
1	2	LEVELLING VALVE W/O HEIGHT LIMIT.	464 008 010 0																			
										PRODUCT IDENTIFICATION NO.	402 156 0	DATE FOR DOCUMENT SHEET	01									
										DENOMINATION	TRAILER - EBS E	DATE FOR SHIPMENT	0425									
										PRODUCT IDENTIFICATION NO.	841 802 156 0	DATE FOR DOCUMENT SHEET	01									
										SIZE	A 3	DATE FOR SHIPMENT										
										CODE FOR FUNCTION	0425	DATE FOR SHIPMENT										
										CODE FOR FUNCTION	0425	DATE FOR SHIPMENT										
										PRODUCT IDENTIFICATION NO.	841 802 156 0	DATE FOR DOCUMENT SHEET	01									
										SIZE	A 3	DATE FOR SHIPMENT										
										CODE FOR FUNCTION	0425	DATE FOR SHIPMENT										
										CODE FOR FUNCTION	0425	DATE FOR SHIPMENT										
										PRODUCT IDENTIFICATION NO.	841 802 156 0	DATE FOR DOCUMENT SHEET	01									
										SIZE	A 3	DATE FOR SHIPMENT										
										CODE FOR FUNCTION	0425	DATE FOR SHIPMENT										
										CODE FOR FUNCTION	0425	DATE FOR SHIPMENT										

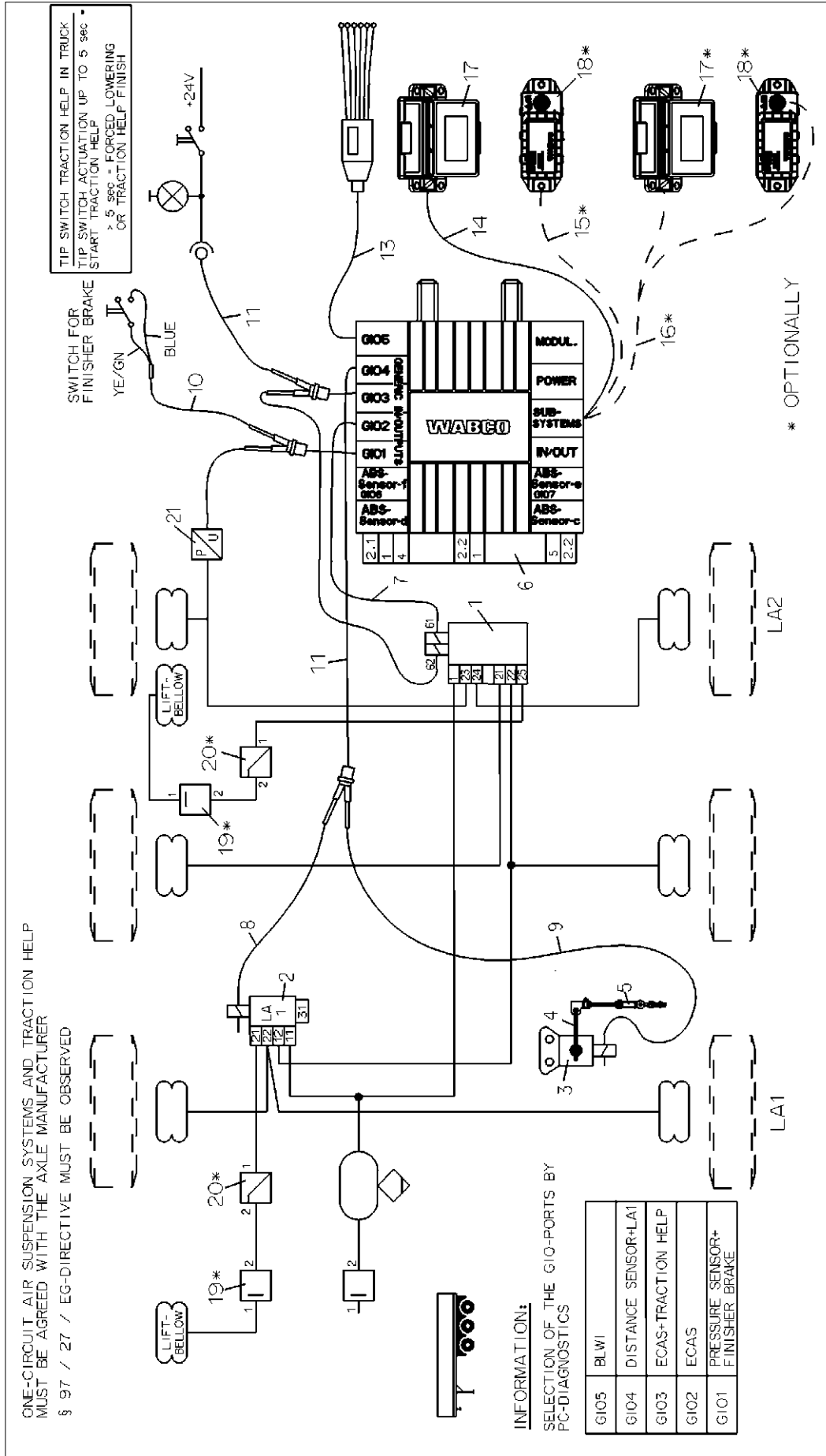

Copyright Wabco,®		WABCO	
Part No.	Substit. No.	TRAILER - EBS E	
07-01-23	APITHY	ECAS WITH TRACTION HELP (VARIATION J)	
07-01-23	GROSSK.	FOR SEMITRAILER	
BURMESTER		ECAS LIFTING+LOWERING, 1-POINT-CONTROL +2 LIFTAXLES	
WABCO TR.		EBS 27 / 97 / 27 / 27 / 27 / 27	
Scale		841 802 157 0	
E3		EN 1/1	
Type 20 S4E...		002 EN 1/1	
A 3 Pro/E		Revision No. 6 4990	
Product Identification No.		123925	
Pos. / Denomination		123925	

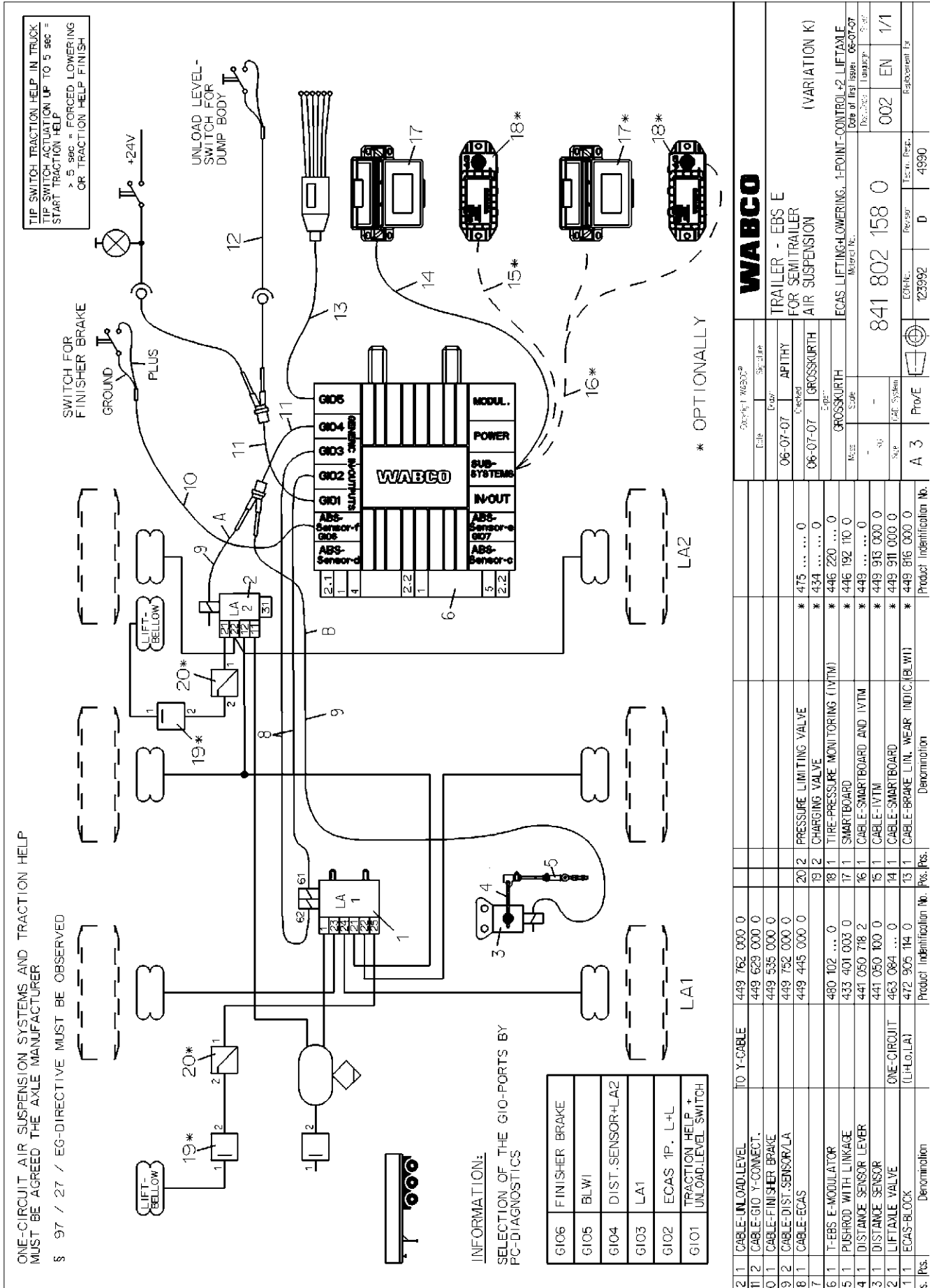

ONE-CIRCUIT AIR SUSPENSION SYSTEMS AND TRACTION HELP
MUST BE AGREED WITH THE AXLE MANUFACTURER
§ 97 / 27 / EG-DIRECTIVE MUST BE OBSERVED

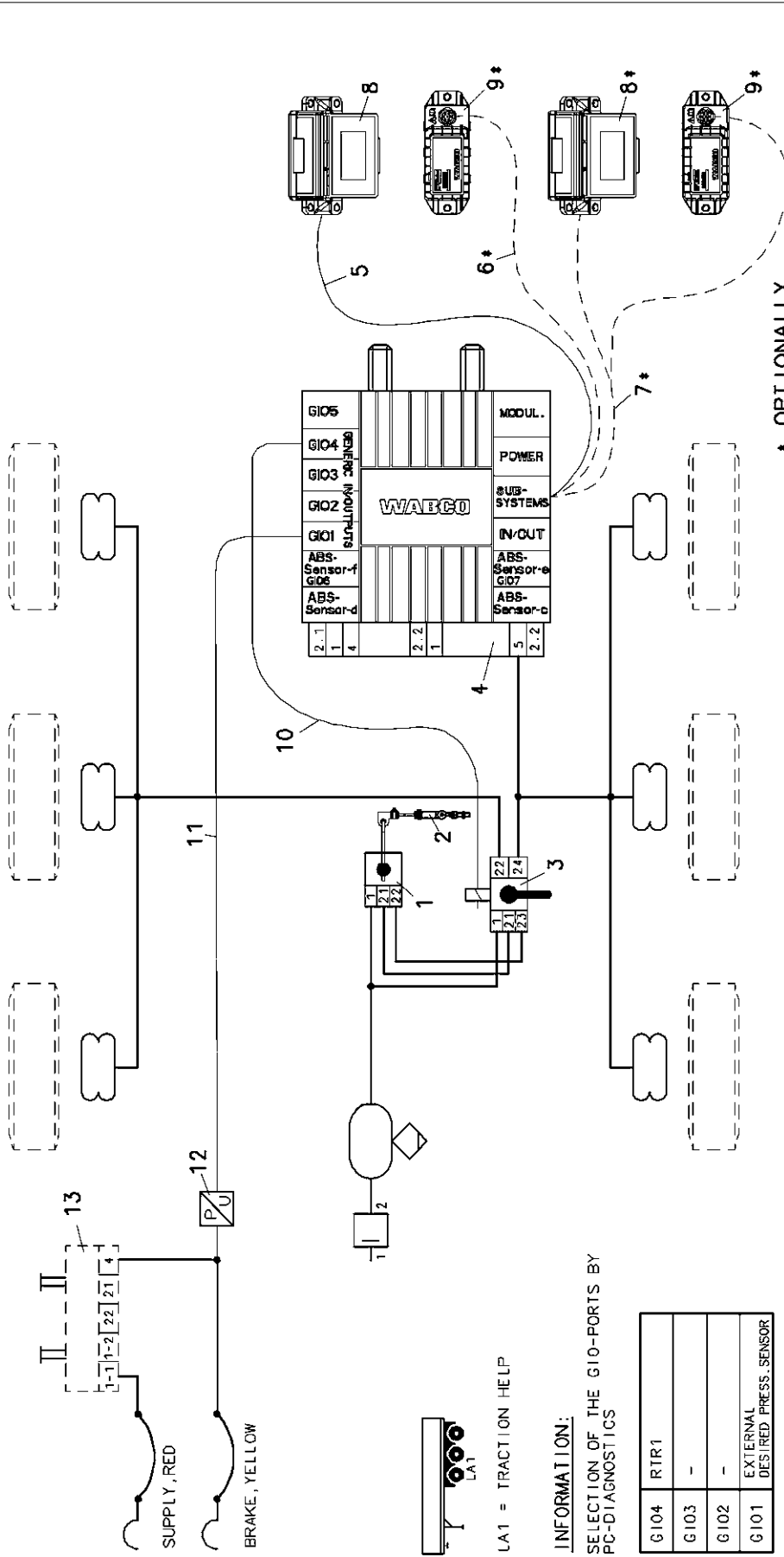

INFORMATION:
SELECTION OF THE GIO-PORTS BY
PC-DIAGNOSTICS

G104	RTR1
G103	-
G102	-
G101	EXTERNAL DESIRED PRESS. SENSOR

13	1	PARK-RELEASE-EMERG.- VALVE (PREV)	441 040 ... 0																		
12	1	PRESSURE SENSOR	449 812 000 0																		
11	1	CABLE-PRESS-SENSOR	449 443 000 0																		
10	2	CABLE-TASC (RTR) AND LIFTAXLE	449 443 000 0																		
9	1	TIRE-PRESSURE MONITOR RING (LVTM) *	446 220 ... 0																		
8	1	SMARTBOARD	446 192 110 0																		
7	1	CABLE-SMARTBOARD AND LVTM *	449 0																		
6	1	CABLE-LVTM *	449 913 000 0																		
5	1	CABLE-SMARTBOARD	449 911 000 0																		
4	1	T-EBS E-MODULATOR	480 102 ... 0																		
3	1	RDL -SLIDE V. W RTR- FUNCT. (TASC)	463 090 00 0																		
2	1	PUSHROD WITH LINKAGE	433 401 003 0																		
-1	1	LEVELLING VALVE W70 HEIGHT LIMIT.	464 006 010 0																		
RES.	RES.	DENOMINATION	PRODUCT IDENTIFICATION NO.	RES.	RES.	DENOMINATION	PRODUCT IDENTIFICATION NO.	RES.	RES.	DENOMINATION	PRODUCT IDENTIFICATION NO.	RES.	RES.	DENOMINATION	PRODUCT IDENTIFICATION NO.	RES.	RES.	DENOMINATION	PRODUCT IDENTIFICATION NO.	RES.	
		WABCO																			
		TRAILER - EBS E																			
		FOR SEMI TRAILER																			
		AIR SUSPENSION																			
		(VARIATION D1)																			
		DRAWN		DATE		SIGNED		DATE		DRAWN		DATE		SIGNED		DATE		DRAWN		DATE	
		07-01-23		07-01-23		07-01-23		07-01-23		07-01-23		07-01-23		07-01-23		07-01-23		07-01-23		07-01-23	
		A 3		A 3		A 3		A 3		A 3		A 3		A 3		A 3		A 3		A 3	
		171		171		171		171		171		171		171		171		171		171	
		841 802 159 0		841 802 159 0		841 802 159 0		841 802 159 0		841 802 159 0		841 802 159 0		841 802 159 0		841 802 159 0		841 802 159 0		841 802 159 0	
		0425		0425		0425		0425		0425		0425		0425		0425		0425		0425	
		402		402		402		402		402		402		402		402		402		402	
		01		01		01		01		01		01		01		01		01		01	
		CODE FOR FUNCTION		CODE FOR FUNCTION		CODE FOR FUNCTION		CODE FOR FUNCTION		CODE FOR FUNCTION		CODE FOR FUNCTION		CODE FOR FUNCTION		CODE FOR FUNCTION		CODE FOR FUNCTION		CODE FOR FUNCTION	
		DATE FOR SWP.		DATE FOR SWP.		DATE FOR SWP.		DATE FOR SWP.		DATE FOR SWP.		DATE FOR SWP.		DATE FOR SWP.		DATE FOR SWP.		DATE FOR SWP.		DATE FOR SWP.	
		REPLACEMENT FOR		REPLACEMENT FOR		REPLACEMENT FOR		REPLACEMENT FOR		REPLACEMENT FOR		REPLACEMENT FOR		REPLACEMENT FOR		REPLACEMENT FOR		REPLACEMENT FOR		REPLACEMENT FOR	
		402		402		402		402		402		402		402		402		402		402	
		01		01		01		01		01		01		01		01		01		01	
		CODE FOR DOCUMENT SHEET		CODE FOR DOCUMENT SHEET		CODE FOR DOCUMENT SHEET		CODE FOR DOCUMENT SHEET		CODE FOR DOCUMENT SHEET		CODE FOR DOCUMENT SHEET		CODE FOR DOCUMENT SHEET		CODE FOR DOCUMENT SHEET		CODE FOR DOCUMENT SHEET		CODE FOR DOCUMENT SHEET	

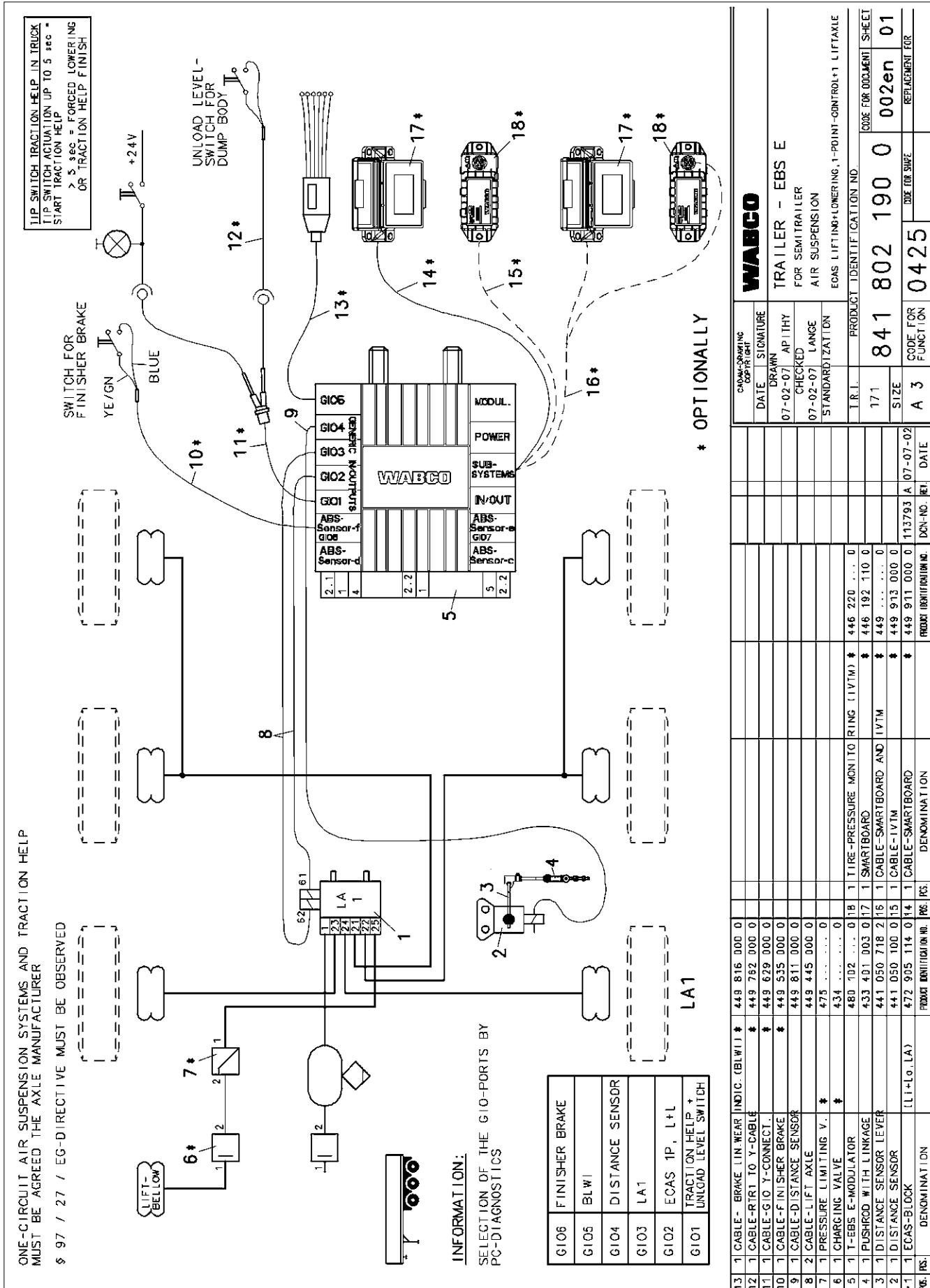

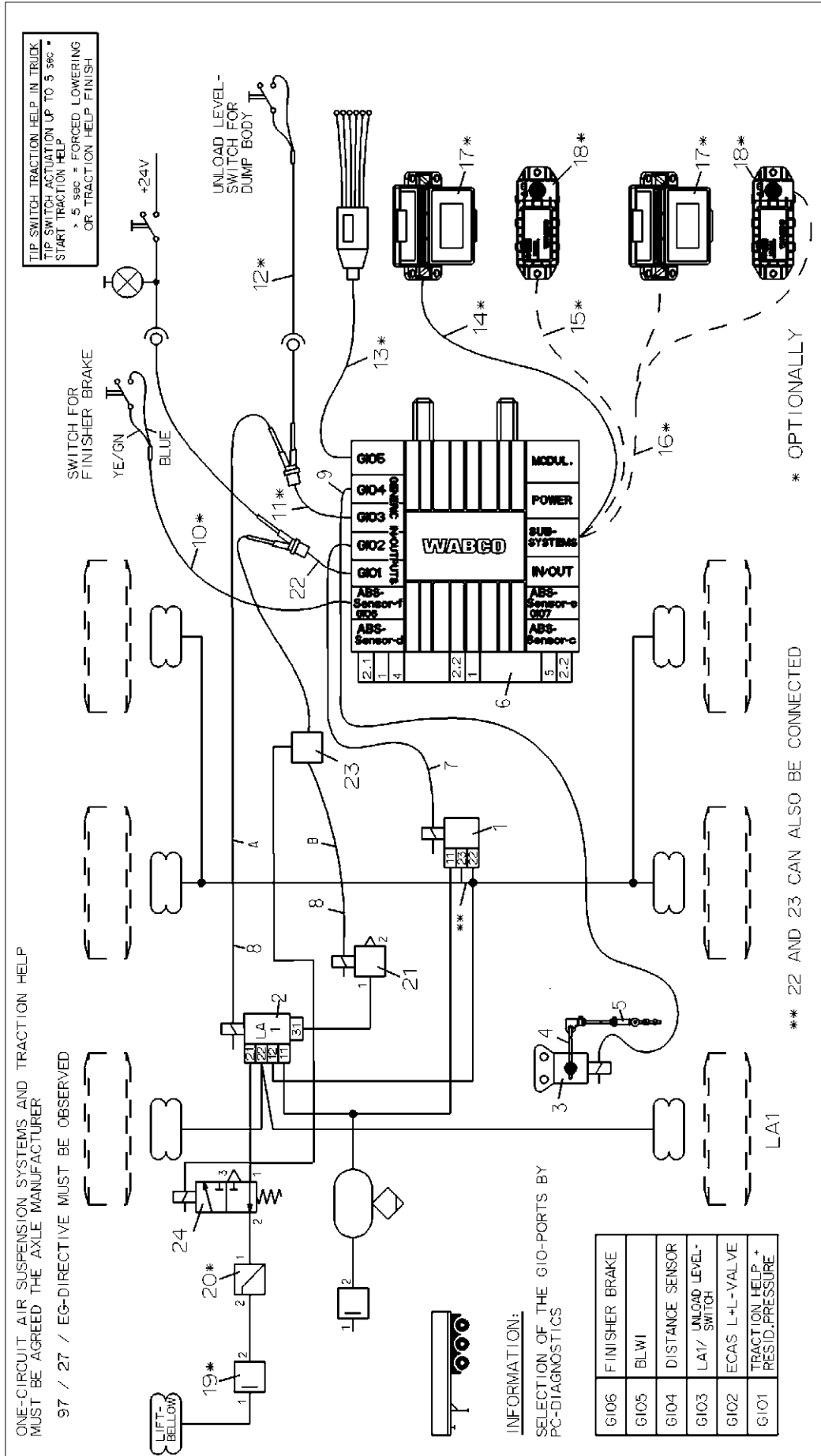

Date		Signature	
07-02-26		APITHY	
07-02-26		GROSSKURTH	
GROSSKURTH		GROSSKURTH	
Date of first issue: 07-02-26		Date of first issue: 07-02-26	
002		EN	
841 802 191 0		841 802 191 0	
A 3		Pro/E	
115294		115294	
C		C	
4990		4990	

WABCO

TRAILER - EBS E
FOR SEMITRAILER
AIR SUSPENSION
ECAS LIFTING+LOWERING
1-POINT-CONTR.-1 LA-MAINTAIN RESIDUAL PRESSURE

472 173 226 0
449 629 000 0
472 175 426 0
475 ... 0
434 ... 0
446 220 ... 0
446 192 110 0
449 ... 0
449 913 000 0
449 911 000 0
449 816 000 0

3/2 SOLENOID VALVE
DISTRIBUTION BOX
CABLE-GIO Y-CONNECT.
SOLENOID VALVE
PRESS.LIMITING-VALVE
CHARGING VALVE
TIRE-PRESSURE MONITORING (IVTM)
SMARTBOARD
CABLE-SMARTBOARD AND IVTM
CABLE-IVTM
CABLE-SMART BOARD
CABLE-BRAKE LIN-WEAR INDIC. (BLWI)

Product Identification No. [Pos.] Denomination

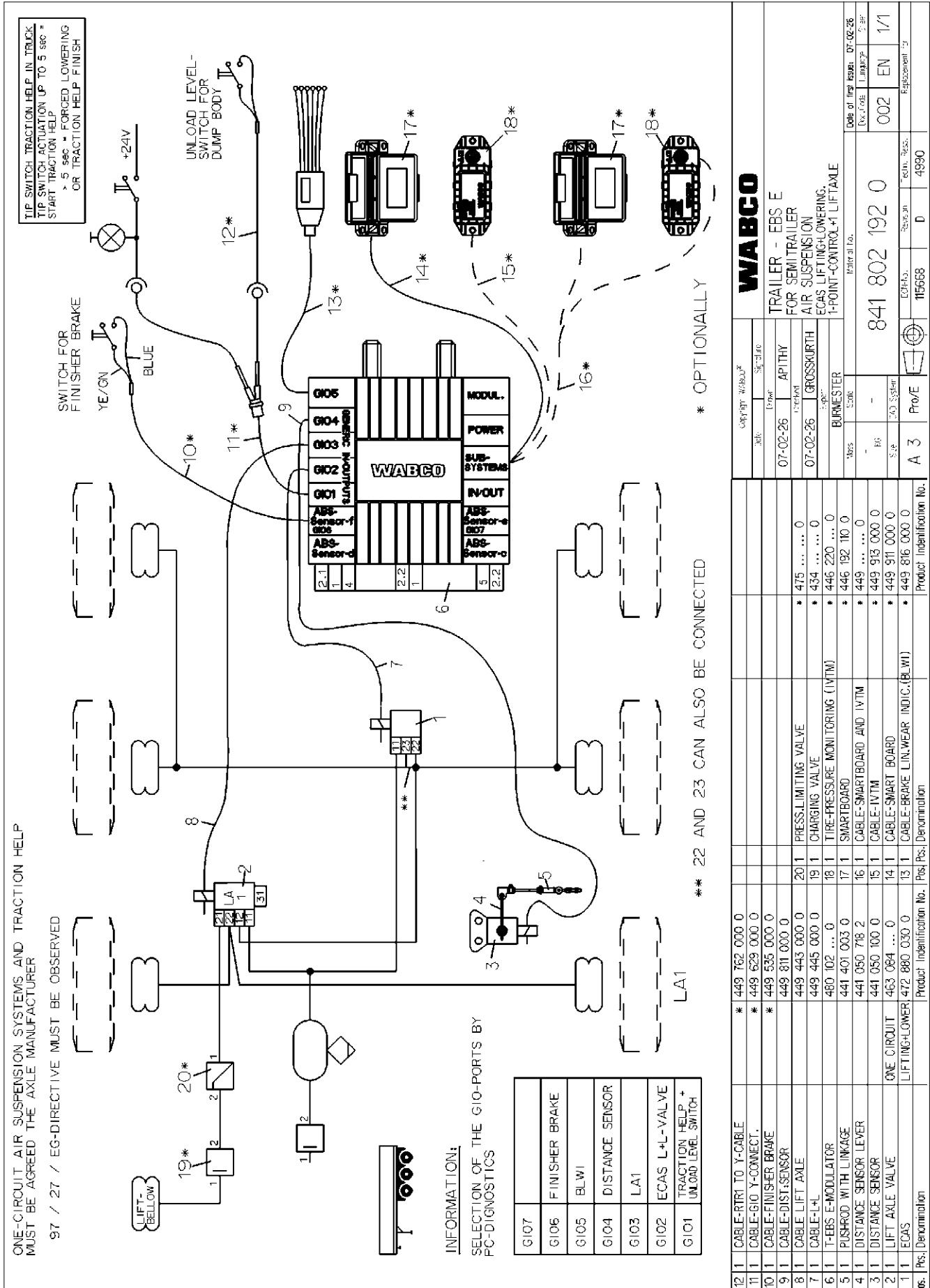

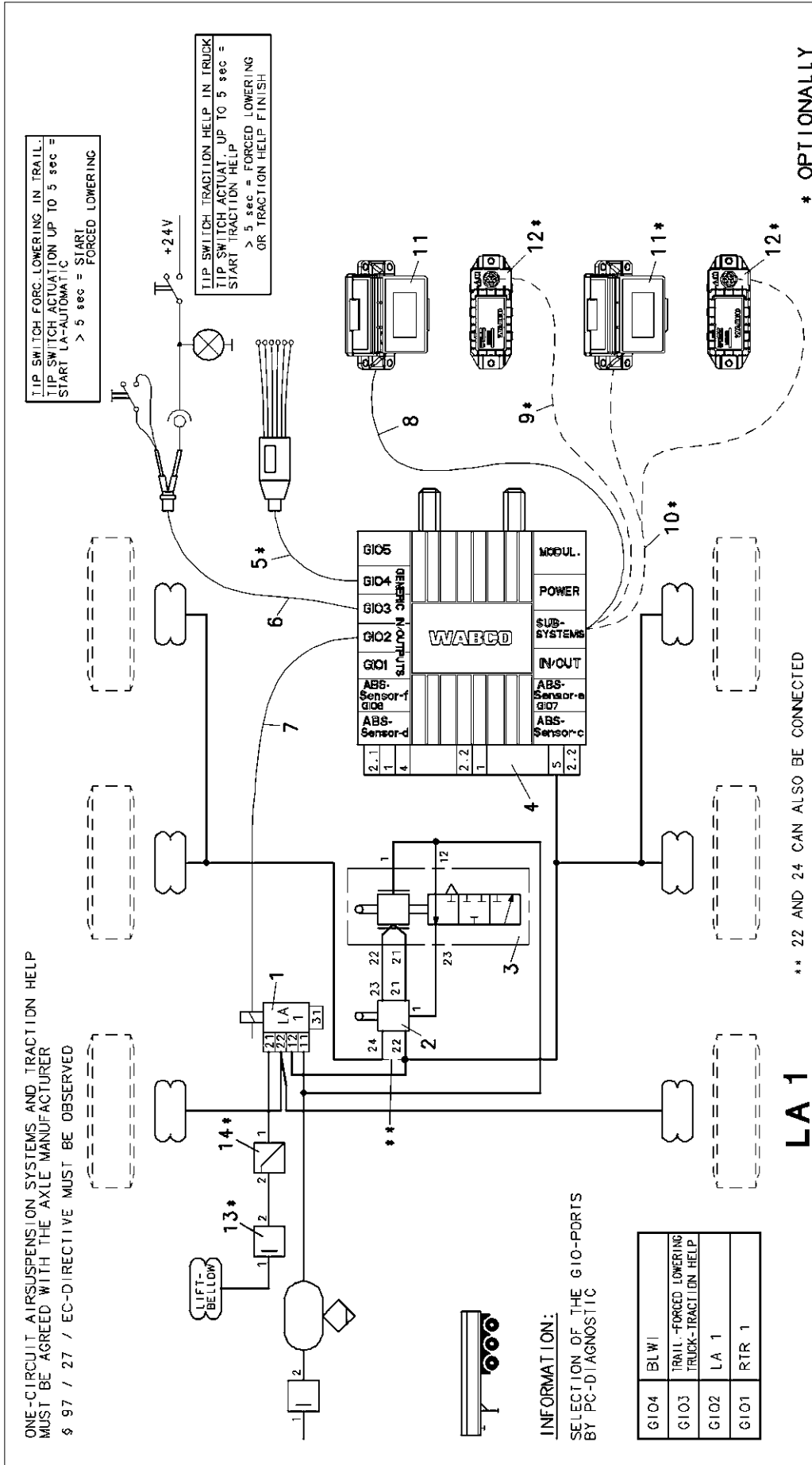

FIG. NOS.	DENOMINATION	PRODOT IDENTIFICATION NO.	FIG.	POS.	DENOMINATION	PRODOT IDENTIFICATION NO.	FIG.	DATE
13	1 CHARGING VALVE	434 ... 0	434	...	0			
12	1 TIRE-PRESSURE MONITOR RING (I/VM) *	446 220 ... 0	446	220	...	0		
11	1 SMARTBOARD	446 182 110 0	446	182	110	0		
10	1 CABLE-SMARTBOARD AND IVTM	449 ... 0	449	0		
9	1 CABLE-IVTM	449 913 000 0	449	913	000	0		
8	1 CABLE-LIFTAXLE	449 443 000 0	449	443	000	0		
7	1 CABLE-TRACT.HELP AND FORCED LOWER.	449 815 000 0	449	815	000	0		
6	1 CABLE- BRAKE LIN.WEAR INDIC.(BLWI) *	480 102 ... 0	480	102	...	0		
5	1 T-EBS E-MODULATOR	464 006 100 0	464	006	100	0		
4	1 LEVELLING VALVE	463 032 020 0	463	032	020	0		
3	1 ROTARY SLIDE VALVE	463 084 ... 0	463	084	...	0		
2	1 LIFT AXLE VALVE	ONE-CIRCUIT	475	0		
1	1 PRESSURE LIMITING V.	...	475	0		

FIG. NOS.	DENOMINATION	PRODOT IDENTIFICATION NO.	FIG.	DATE
13	1 CHARGING VALVE	434 ... 0	434	...
12	1 TIRE-PRESSURE MONITOR RING (I/VM) *	446 220 ... 0	446	...
11	1 SMARTBOARD	446 182 110 0	446	...
10	1 CABLE-SMARTBOARD AND IVTM	449 ... 0	449	...
9	1 CABLE-IVTM	449 913 000 0	449	...
8	1 CABLE-LIFTAXLE	449 443 000 0	449	...
7	1 CABLE-TRACT.HELP AND FORCED LOWER.	449 815 000 0	449	...
6	1 CABLE- BRAKE LIN.WEAR INDIC.(BLWI) *	480 102 ... 0	480	...
5	1 T-EBS E-MODULATOR	464 006 100 0	464	...
4	1 LEVELLING VALVE	463 032 020 0	463	...
3	1 ROTARY SLIDE VALVE	463 084 ... 0	463	...
2	1 LIFT AXLE VALVE	ONE-CIRCUIT	475	...
1	1 PRESSURE LIMITING V.	...	475	...

LA 1 ** 22 AND 24 CAN ALSO BE CONNECTED

WABCO
 TRAILER -- EBS E
 FOR SEMITRAILER
 AIR SUSPENSION
 W. LEVELLING VALVE A. ONE-CIRC. LIFT AXLE VALVE

CAD/DRAWING CONTROL	DATE	SIGNATURE
DRAWN	07-07-31	APHITHY
CHECKED	07-07-31	CHRONIS
STANDARDIZATION	PRODUCT IDENTIFICATION NO.	
T.R.I.	171	841 802 193 0
SIZE	A 3	002en 01
CODE FOR FUNCTION	0425	REPLACEMENT FOR
CODE FOR DOCUMENT SHEET		

INFORMATION:

SELECTION OF THE GIO-PORTS BY PC-DIAGNOSTIC

GIO4	BLWI
GIO3	TRAIL-FORCED LOWERING TRUCK-TRACTION HELP
GIO2	LA 1
GIO1	RTR 1

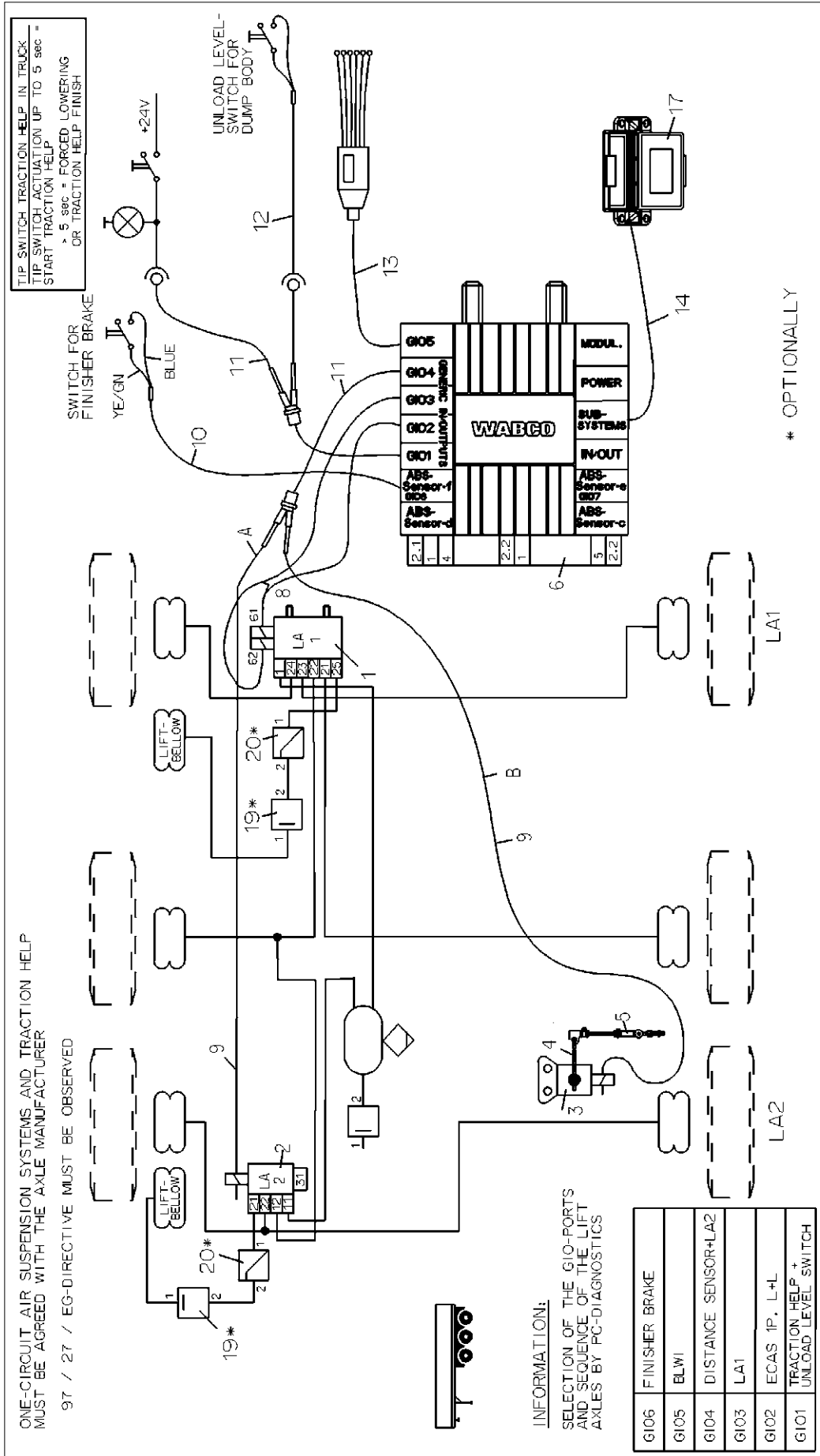

Pos./Pos.	Denomination	Product Identification No.	Pos./Pos.	Denomination	Product Identification No.	Quantity WABCO®		Date of first issue: 2008-01-14	
						Part	Signature		
12	CABLE-UNLOAD LEVEL	449 762 000 0	17	SMART BOARD	446 192 110 0	2008-01-14	BURMESTER	2008-01-14	
11	CABLE-G10 Y-CONNECTOR	449 629 000 0	18	CABLE SMART BOARD	443 003 000 0	2008-01-14	GROSSKURTH	2008-01-14	
10	CABLE-FINISHER BRAKE	449 535 000 0	19	CABLE-BRAKE LINWEAR INDIC. (BLWI)	449 816 000 0	2008-01-14	BURMESTER	2008-01-14	
9	CABLE-DISTANCE SENSOR/LA	449 752 000 0	20	CABLE-BRAKE LINWEAR INDIC. (BLWI)	449 816 000 0	2008-01-14	GROSSKURTH	2008-01-14	
8	CABLE-ECAS	449 445 000 0	21	CABLE-BRAKE LINWEAR INDIC. (BLWI)	449 816 000 0	2008-01-14	BURMESTER	2008-01-14	
7	T-ECAS E-MODULATOR	480 102 ... 0	22	CABLE-BRAKE LINWEAR INDIC. (BLWI)	449 816 000 0	2008-01-14	BURMESTER	2008-01-14	
6	PUSH ROD WITH LINKAGE	433 401 003 0	23	CABLE-BRAKE LINWEAR INDIC. (BLWI)	449 816 000 0	2008-01-14	BURMESTER	2008-01-14	
5	DISTANCE SENSOR LEVER	441 050 718 2	24	CABLE-BRAKE LINWEAR INDIC. (BLWI)	449 816 000 0	2008-01-14	BURMESTER	2008-01-14	
4	DISTANCE SENSOR	441 050 100 0	25	CABLE-BRAKE LINWEAR INDIC. (BLWI)	449 816 000 0	2008-01-14	BURMESTER	2008-01-14	
3	LIFT AXLE VALVE	463 064 ... 0	26	CABLE-BRAKE LINWEAR INDIC. (BLWI)	449 816 000 0	2008-01-14	BURMESTER	2008-01-14	
2	LIFT AXLE BLOCK	472 905 114 0	27	CABLE-BRAKE LINWEAR INDIC. (BLWI)	449 816 000 0	2008-01-14	BURMESTER	2008-01-14	
1	ECAS-BLOCK	472 905 114 0	28	CABLE-BRAKE LINWEAR INDIC. (BLWI)	449 816 000 0	2008-01-14	BURMESTER	2008-01-14	
							Material No.:	841 802 194 0	Replacement for
							Part No.:	002	EN
							Rev. No.:	1/1	
							Part No.:	4990	

WABCO

TRAILER - EBS E
 FOR SEMITRAILER
 AIR SUSPENSION

* OPTIONALLY

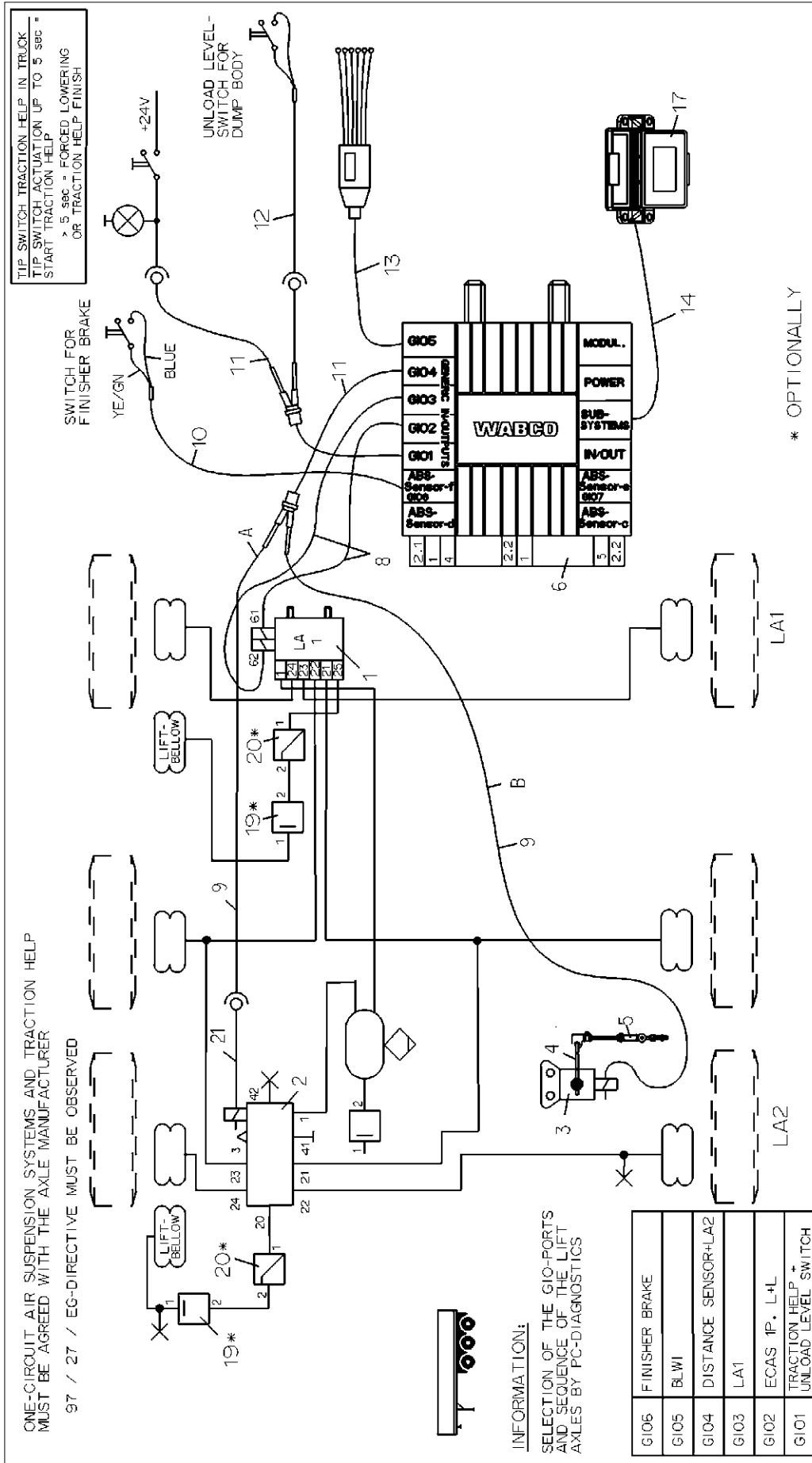

* OPTIONALLY

Copyright WABCO®		WABCO	
Info	Part	Signature	
2008-01-29	BURMESTER		
2008-01-29	GROSSKURTH		
Burmeister		ECAS LIFTING+LOWERING, 1-POINT-CONTROL+2 LIFTAXLE	
Mod.	Part	Model No.	
		841 802 195 0	
Rev.			
Sup.	Part	Part	
A 3	Pro/E		
Product Identification No.		4990	

12 1	CABLE-UNLOAD-LEVEL	449 762 000 0	
11 2	CABLE-G10 Y-CONNECTOR	449 629 000 0	
10 1	CABLE-FINISHER BRAKE	449 535 000 0	
9 2	CABLE-DISTANCE SENSOR/LA	449 752 000 0	21 1
8 1	CABLE-ECAS	449 445 000 0	20 2
7			19 2
6 1	T-EBS E-MODULATOR	480 102 ... 0	18
5 1	PUSH ROD WITH LINKAGE	433 401 003 0	17 1
4 1	DISTANCE SENSOR LEVER	441 050 718 2	16
3 1	DISTANCE SENSOR	441 050 100 0	15
2 1	LIFT AXLE VALVE	463 084 010 0	14 1
1 1	ECAS-BLOCK	472 905 114 0	13 1
Pos/Pos	Denomination	Product Identification No.	Pos./Pos.

TIP SWITCH TRACTION HELP IN TRUCK
 TIP SWITCH TRACTION HELP UP TO 5 sec -
 START TRACTION HELP
 > 5 sec - FORCED LOWERING
 OR TRACTION HELP FINISH

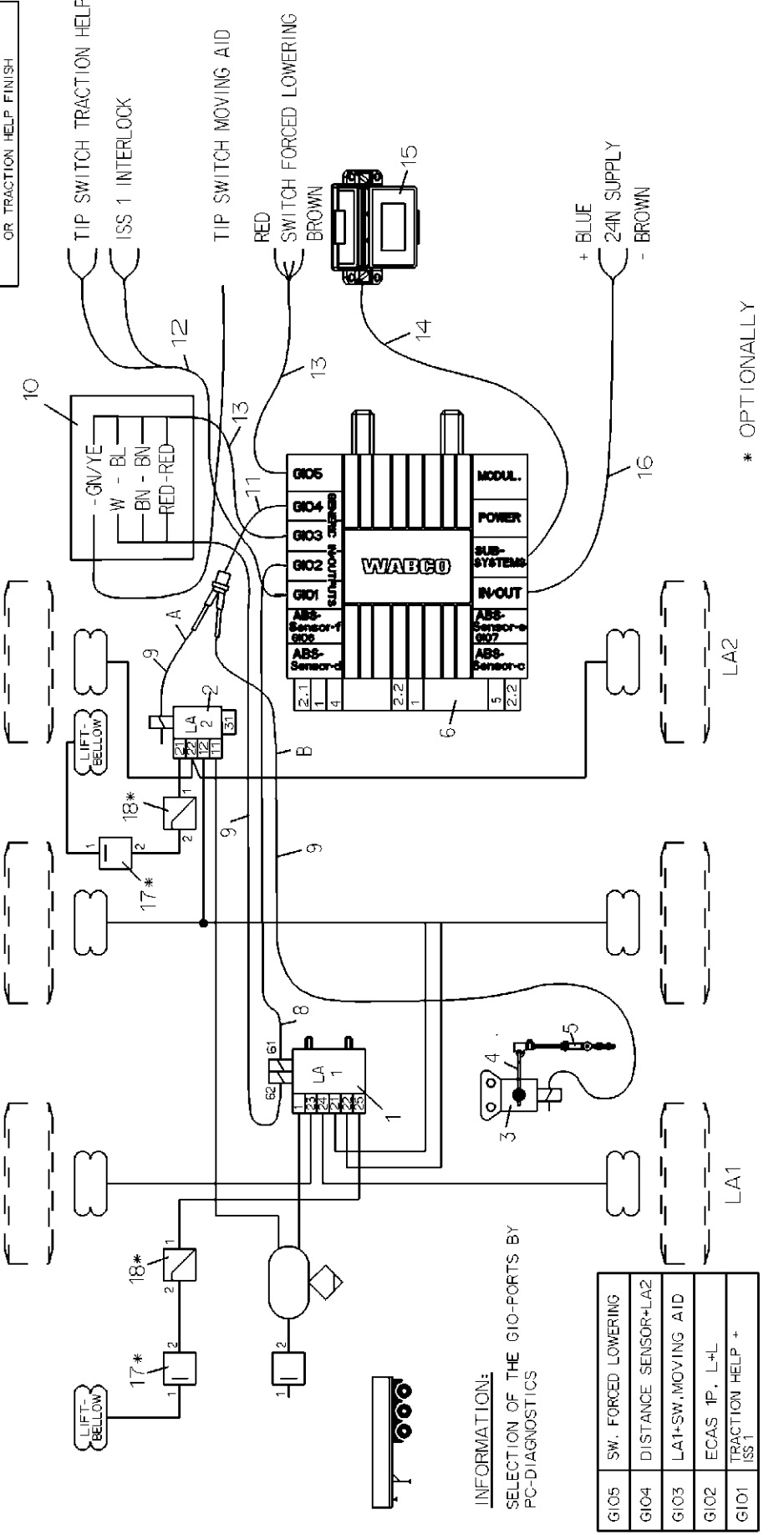

ONE-CIRCUIT AIR SUSPENSION SYSTEMS AND TRACTION HELP
 MUST BE AGREED THE AXLE MANUFACTURER
 § 97 / 27 / EG-DIRECTIVE MUST BE OBSERVED

INFORMATION:
 SELECTION OF THE GIO-PORTS BY
 PC-DIAGNOSTICS

GIO5	SW. FORCED LOWERING
GIO4	DISTANCE SENSOR+LA2
GIO3	LA1+SW.MOVING AID
GIO2	ECAS IP, L+L
GIO1	TRACTION HELP + ISS1

* OPTIONALLY

Date		Signature		WABCO	
2008-10-08		BURMESTER		TRAILER - EBS E FOR SEMI TRAILER AIR SUSPENSION	
2008-10-08		CHRONIS		ECAS LIFTING-LOWERING, 1-POINT-CONTROL, +2 LIFTAXLES	
Burmes		State		Date of first issue: 2008-10-08	
-		-		Part No.	
-		-		841 802 196 0	
A 3		Pro/E		Techn. Resp.	
449 815 253 0		449 629 022 0		449 752 ... 0	
449 445 ... 0		480 102 ... 0		433 401 003 0	
441 050 718 2		441 050 100 0		463 084 ... 0	
472 905 114 0		449 627 060 0		449 535 060 0	
449 815 253 0		449 629 022 0		449 752 ... 0	
449 445 ... 0		480 102 ... 0		433 401 003 0	
441 050 718 2		441 050 100 0		463 084 ... 0	
472 905 114 0		449 627 060 0		449 535 060 0	
449 815 253 0		449 629 022 0		449 752 ... 0	
449 445 ... 0		480 102 ... 0		433 401 003 0	
441 050 718 2		441 050 100 0		463 084 ... 0	
472 905 114 0		449 627 060 0		449 535 060 0	

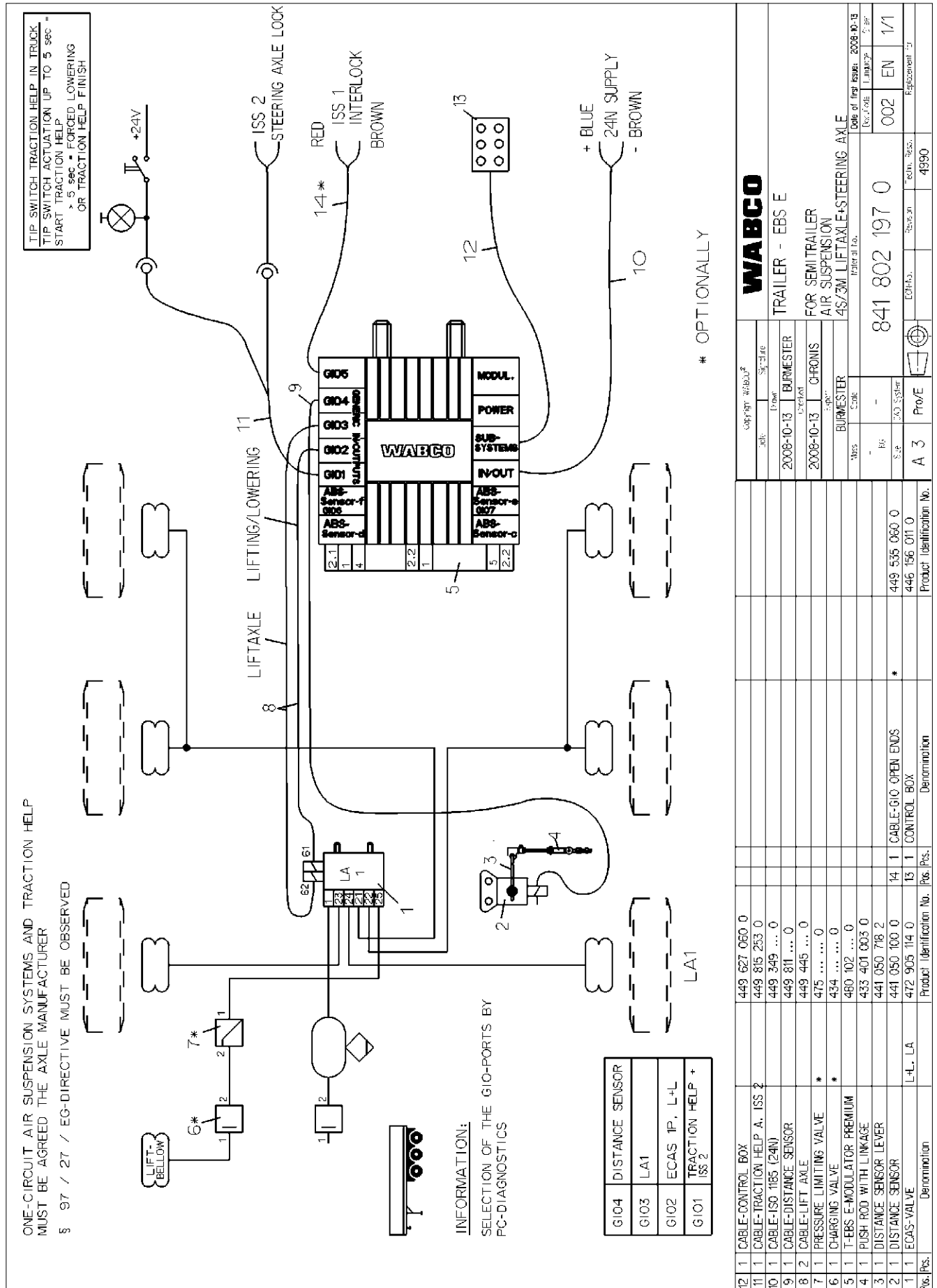

TIP SWITCH TRACTION HELP IN TRUCK
 TIP SWITCH ACTUATION UP TO 5 sec=
 START TRACTION HELP
 > 5 sec = FORCED LOWERING
 OR TRACTION HELP FINISH

PROXIMITY SWITCH AS
 UNLOAD LEVEL SWITCH

ONE-CIRCUIT AIR SUSPENSION SYSTEMS AND TRACTION HELP
 MUST BE AGREED THE AXLE MANUFACTURER

§ 97 / 27 / EG-DIRECTIVE MUST BE OBSERVED

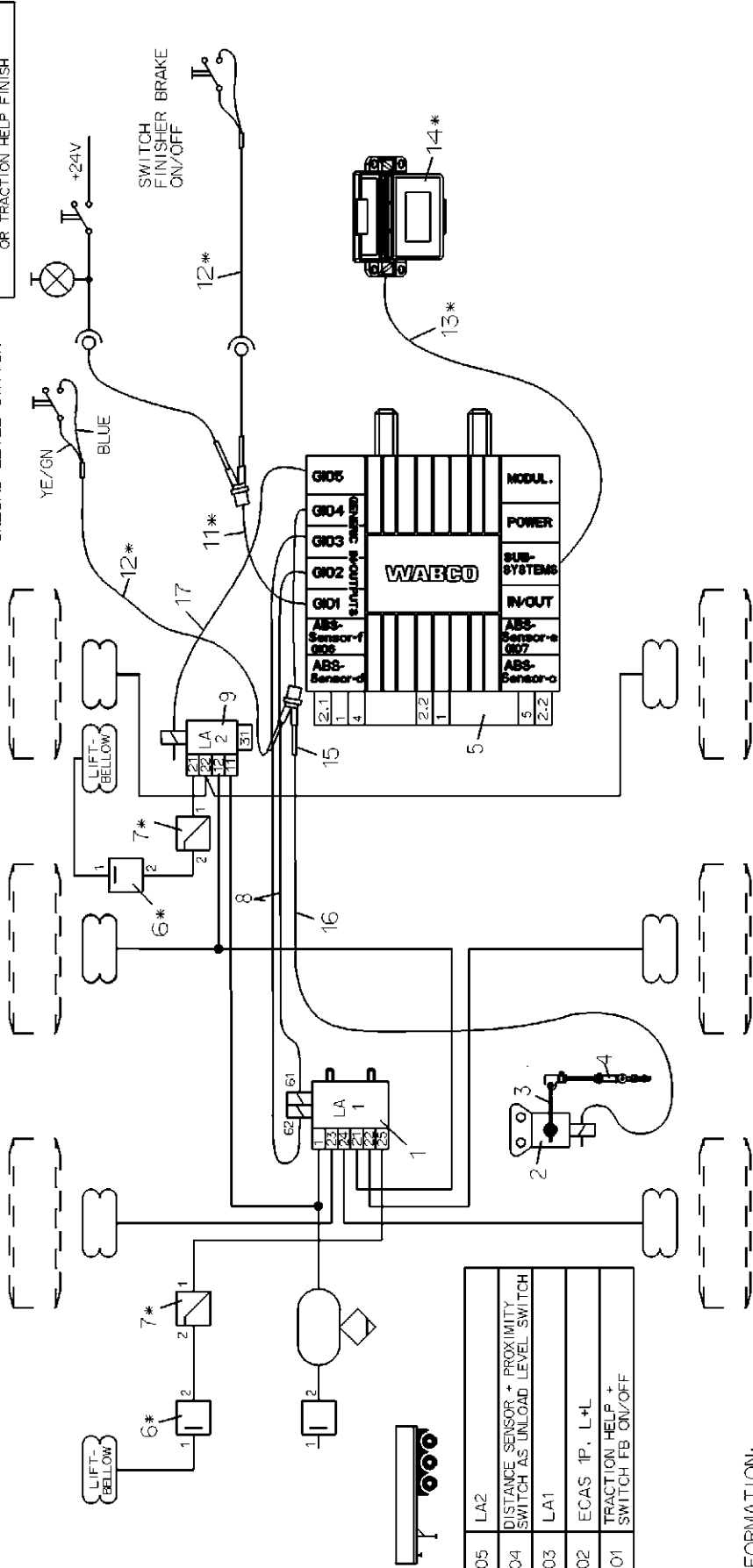

*OPTIONALLY

INFORMATION:
 SELECTION OF THE GIO-PORTS BY
 PC-DIAGNOSTICS

Pos./Pos.	Denomination	Product Identification No.	Pos./Pos.	Denomination	Product Identification No.
12 2	CABLE-RTTR1 TO Y-CABLE	449 762 000 0	17 1	CABLE-LIFTAXLE	449 443 000 0
11 1	CABLE-G10 Y-CONNECTOR	449 629 000 0	16 1	CABLE-DISTANCE SENSOR	449 752 000 0
9 1	LIFTAXLE VALVE	463 084 ... 0	15 1	Y-CONNECTOR	449 629 000 0
8 1	CABLE-LIFT AXLE	449 445 000 0	14 1	SMARTBOARD	446 192 110 0
7 2	PRESSURE LIMITING VALVE	475 ... 0	13 1	CABLE-SMARTBOARD	449 911 000 0
6 2	CHARGING VALVE	434 ... 0			
5 1	T-EBS E-MODULATOR (E1)	480 102 ... 0			
4 1	PUSH ROD WITH LINKAGE	433 401 003 0			
3 1	DISTANCE SENSOR LEVER	441 050 718 2			
2 1	DISTANCE SENSOR	441 050 100 0			
1 1	ECAS-BLOCK	472 905 114 0			

Copy right WABCO®	Part No.	Symbol	Doc. Code	Date of first issue: 2008-05-19
	2008-05-19	BURMESTER	841 802 198 0	EN 1/1
	2008-05-19	GROSSKURTH		
TRAILER - EBS E FOR SEMITRAILER (VARIANTE L) AIR SUSPENSION WITH T-EBS E1 ECAS LIFTING-LOWERING, 1-POINT-CONTROL + 2 LIFTAXLES				
Mod.	300.7	Mod. No.	4990	
Rev.	-	Doc. Code	841 802 198 0	
SP	LA0 System	Proj. No.	120591	
A 3	Pro/E	Rev. No.	B	

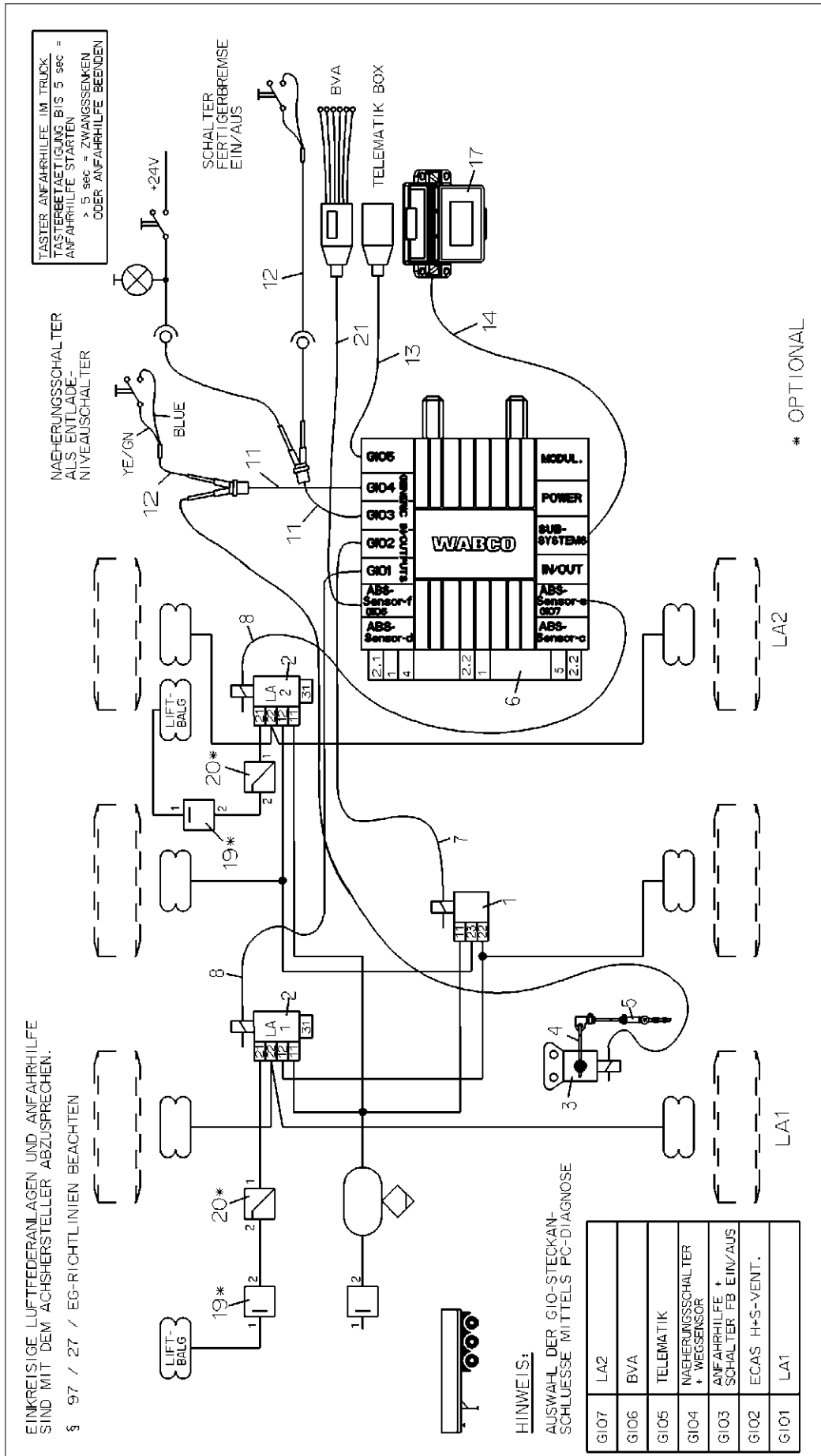

Date		Signature	
2008-05-20	BURMESTER	449 816 000 0	
2008-05-20	GROSSKURTH	* 475 ... 0	
		* 434 ... 0	
		* 446 220 ... 0	
		* 446 192 110 0	
		* 449 ... 0	
		* 449 913 000 0	
		* 449 911 000 0	
		449 915 000 0	

WABCO
TRAILER - EBS E
FLUR SATTELANHAENGER 2S/2M
LUFTFEDERUNG MIT T-EBS ET
ECAS HEBBEN-SENKEN. 1-PKT.-REGLG. + 2 LIFTACHSEN

841 802 199 0

Page of 1
Date of first issue: 2008-05-20
Doc. No. 841 802 199 0
Sheet 1/1

Pro/E A 3
SCHUB. 4990
Techn. Rep. 4990

Product Identification No. 449 762 000 0
449 629 000 0
449 443 000 0
449 445 000 0
480 102 ... 0
433 401 003 0
441 050 718 2
441 050 100 0
463 084 ... 0
472 880 030 0

Product Identification No. 449 816 000 0
* 475 ... 0
* 434 ... 0
* 446 220 ... 0
* 446 192 110 0
* 449 ... 0
* 449 913 000 0
* 449 911 000 0
449 915 000 0

Denomination

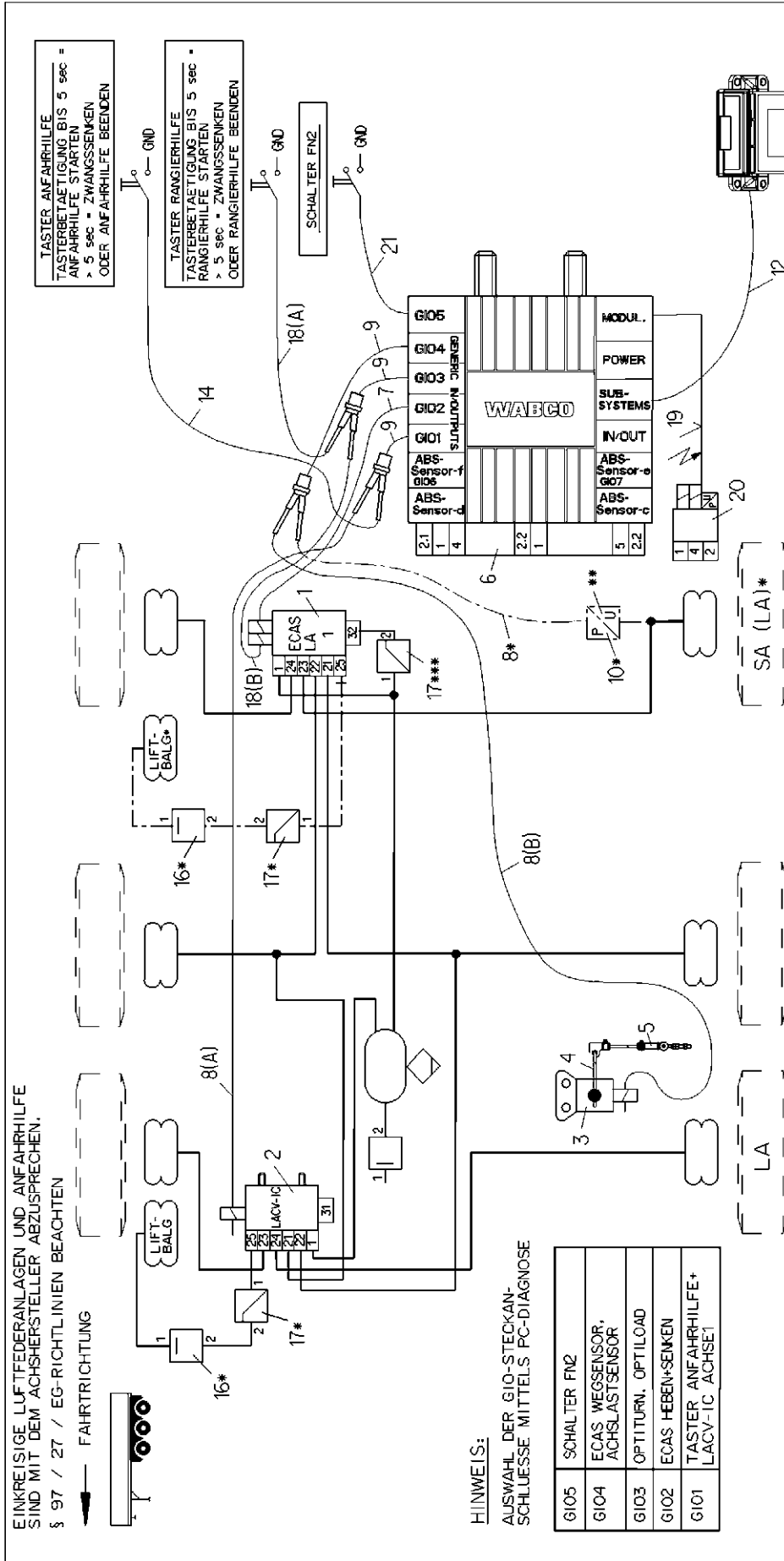

INDEX G DATUM 2015-01-19 BESCHREIBUNG DER AENDERUNG POS.11: GELOESCHT POS.8: ANZAHL GEÄNDERT IN 3

Copyright WABCO		WABCO	
Jahr	Stapel	TRAILER - EBS E PREMIUM	
2009-08-24	BURMESTER	FUER SATTELANHAENGER	
2009-08-24	LANGOWICZ	4S/3M, ECAS HS, OPTITURN/OPTILOAD M. ECAS, ANFAHRHILFE, AUF ACHSE1, SCHLEPPA. SMARTBOARD	
Mod.	Stapel	841 802 235 0	
13	20	002 DE 1/1	
A 3	Pro/E	6 4990 HWR 00658	
Product Identification No.		Denomination	

* OPTIONAL, SONST ANSCHLUSS 25 BEI ECAS LA1 VERSCHLOSSEN
 ** IN VERANTWORTUNG DES FAHRZEUGHERSTELLERS, JE NACH FAHRZEUGKONSTRUKTION
 *** NUR BEI SCHLEPPACHSEN, OPTIONAL AB EBS E 2.0

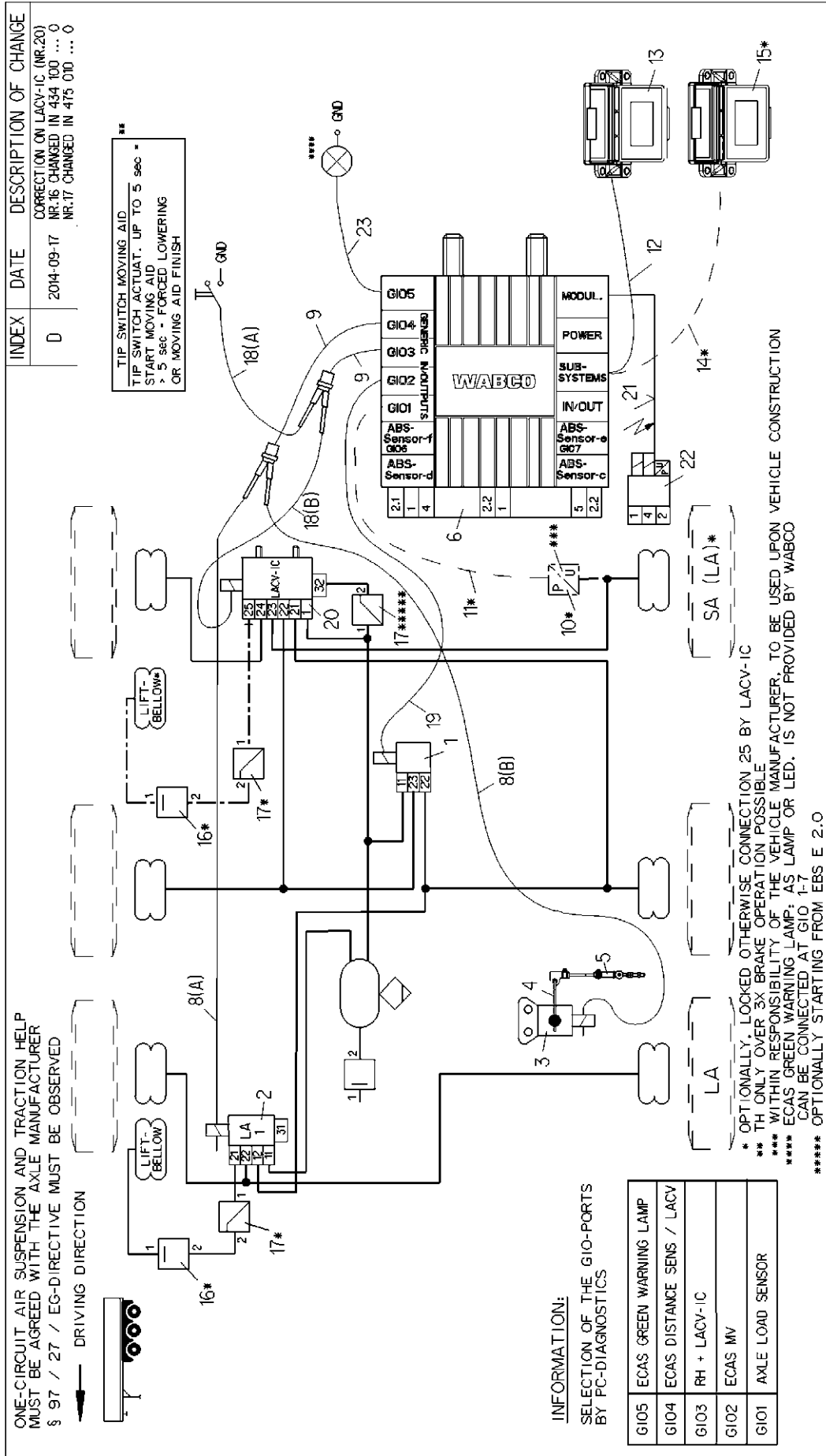

Pos./Pos.	Denomination	Product Identification No.	Pos. Pos.	Denomination	Product Identification No.
12	CABLE-SMART BOARD	449 911 000 0			
11	CABLE-PRESSURE SENSOR	* 449 812 ... 0	23	1	CABLE TO WARNING LAMP
10	PRESSURE SENSOR	* 441 044 ... 0	22	1	EBS RV
9	CABLE-GIO Y-DISTRIBUTOR	449 629 000 0	21	1	CABLE TO EBS RV
8	CABLE-DISTANCE SENSOR/LA	449 752 000 0	20	1	LACV-IC
7	T-EBS E-MODULATOR	480 102 ... 0	19	1	CABLE-ECAS BLOCK
6	PUSH ROD WITH LINKAGE	433 401 003 0	18	2	RH-SWITCH CABLE A, LACV-IC CABLE
5	DISTANCE SENSOR LEVER	441 050 718 2	17	3	PRESSURE LIMITING VALVE
4	DISTANCE SENSOR	441 050 100 0	16	2	CHARGING VALVE
3	LIFT AXLE VALVE	463 084 ... 0	15	1	CONTROL BOX
2	ECAS-BLOCK	472 860 030 0	14	1	CABLE-CONTROL BOX
1			13	1	SMART BOARD

WABCO
TRAILER - EBS E1 PREMIUM
FOR SEMI-TRAILER
4S/3M, ECAS L4L, OPTI TURN A, OPTILOAD, GN-WARNING LAMP
LIFT-AXLE ON AXLE 1, DRAGGING AXLE ON AXLE 3, SMARTB.

841 802 236 0

002 EN 1/1

4990

HMR 00858

841 802 237 0

ONE-CIRCUIT AIR SUSPENSION SYSTEMS AND TRACTION HELP
MUST BE AGREED WITH THE AXLE MANUFACTURER
§ 97 / 27 / EG-DIRECTIVE MUST BE OBSERVED

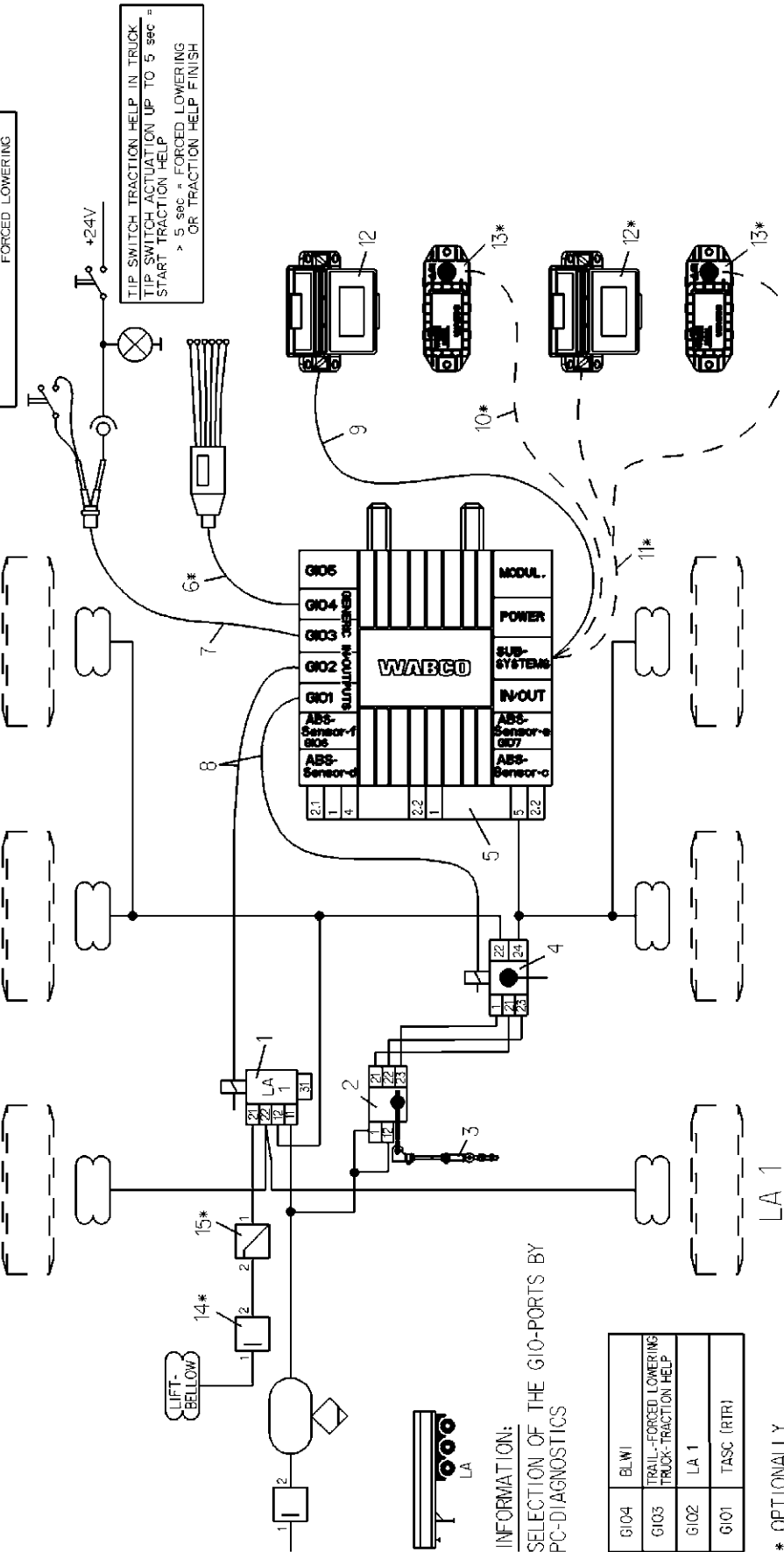

INFORMATION:
SELECTION OF THE GIO-PORTS BY
PC-DIAGNOSTICS

GIO4	BLW1
GIO3	TRAIL-FORCED LOWERING TRUCK-TRACTION HELP
GIO2	LA 1
GIO1	TASC (TR)

* OPTIONALLY

WABCO			2009-11-23 BURMESTER				2009-11-23 LANGOWICZ			
TRAILER - EBS E			BURMESTER				LANGOWICZ			
FOR SEMITRAILER			BURMESTER				BURMESTER			
AIR SUSPENSION			BURMESTER				BURMESTER			
W-LEVELLING VALVE AND ONE-CIRCUIT LIFTAXLE VALVE			BURMESTER				BURMESTER			
841 802 237 0			841 802 237 0				841 802 237 0			
Pro/E			A 3				A 3			
123662			123662				123662			
EN 1/1			EN 1/1				EN 1/1			
4990			4990				4990			

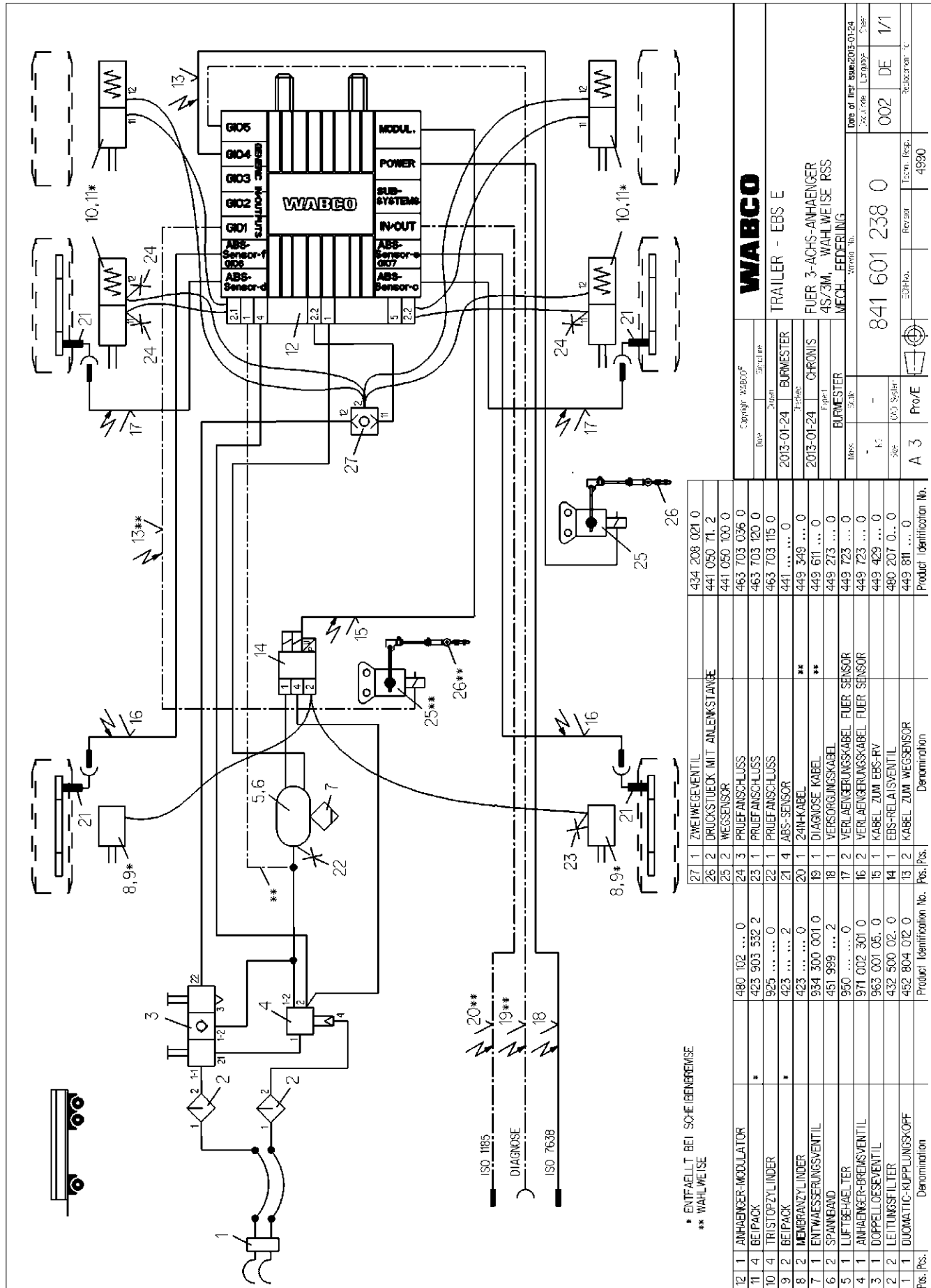

* ENTFABRT BEI SCHEIBENBREMSE
 ** WAHLWEISE

12	1 ANHAENGER-MODULATOR	480 102 ... 0	27 1 ZWEIFLUECHTIGES	434 208 021 0
11	4 BEIPACK	423 903 532 2	26 2 DRUCKSTUECK MIT ANLENKSTANGE	441 050 71 2
10	4 TRISTOPZYLINDER	925 0	25 2 WEGSENSOR	441 050 100 0
9	2 BEIPACK	423 2	24 3 PRUEFANSCHLUSS	463 703 036 0
8	2 MEMBRANZYLINDER	423 0	23 1 PRUEFANSCHLUSS	463 703 120 0
7	1 ENTWASSERUNGSVENTIL	934 300 001 0	22 1 PRUEFANSCHLUSS	463 703 115 0
6	2 SPANNBAND	451 999 ... 2	21 4 ABS-SENSOR	441 0
5	1 LUFTBEHAELTER	950 0	20 1 2-IN-KABEL	449 349 ... 0
4	1 ANHAENGER-BREMSENVENTIL	971 002 301 0	19 1 DIAGNOSE KABEL	449 611 ... 0
3	1 DOBELLEINLEITER	963 001 05 0	18 1 VERSORGNUNGSKABEL	449 273 ... 0
2	2 LEITUNGSFILTER	432 500 02 0	17 2 VERLAEGERUNGSKABEL FUER SENSOR	449 723 ... 0
1	1 DUCOMATIC-KUPPLUNGSKOPF	452 804 012 0	16 2 VERLAEGERUNGSKABEL FUER SENSOR	449 723 ... 0
Pos./Pos.	Denomination	Product Identification No.	Pos./Pos.	Denomination

WABCO
 TRAILER - EBS E
 FUER 3-ACHS-ANHAENGER
 4S/3M, WAHLWEISE RSS
 MECH. FEDERUNG

Copyright WABCO®
 Rep: 2013-01-24
 Model: BURMESTER
 Part: 2013-01-24
 Part: CHRONIS
 Part: BURMESTER

Vertraulich!
 Date of first issue: 2013-01-24
 Drawn: 002
 Checked: DE
 Scale: 1/1
 Techn. Resp.: 4990

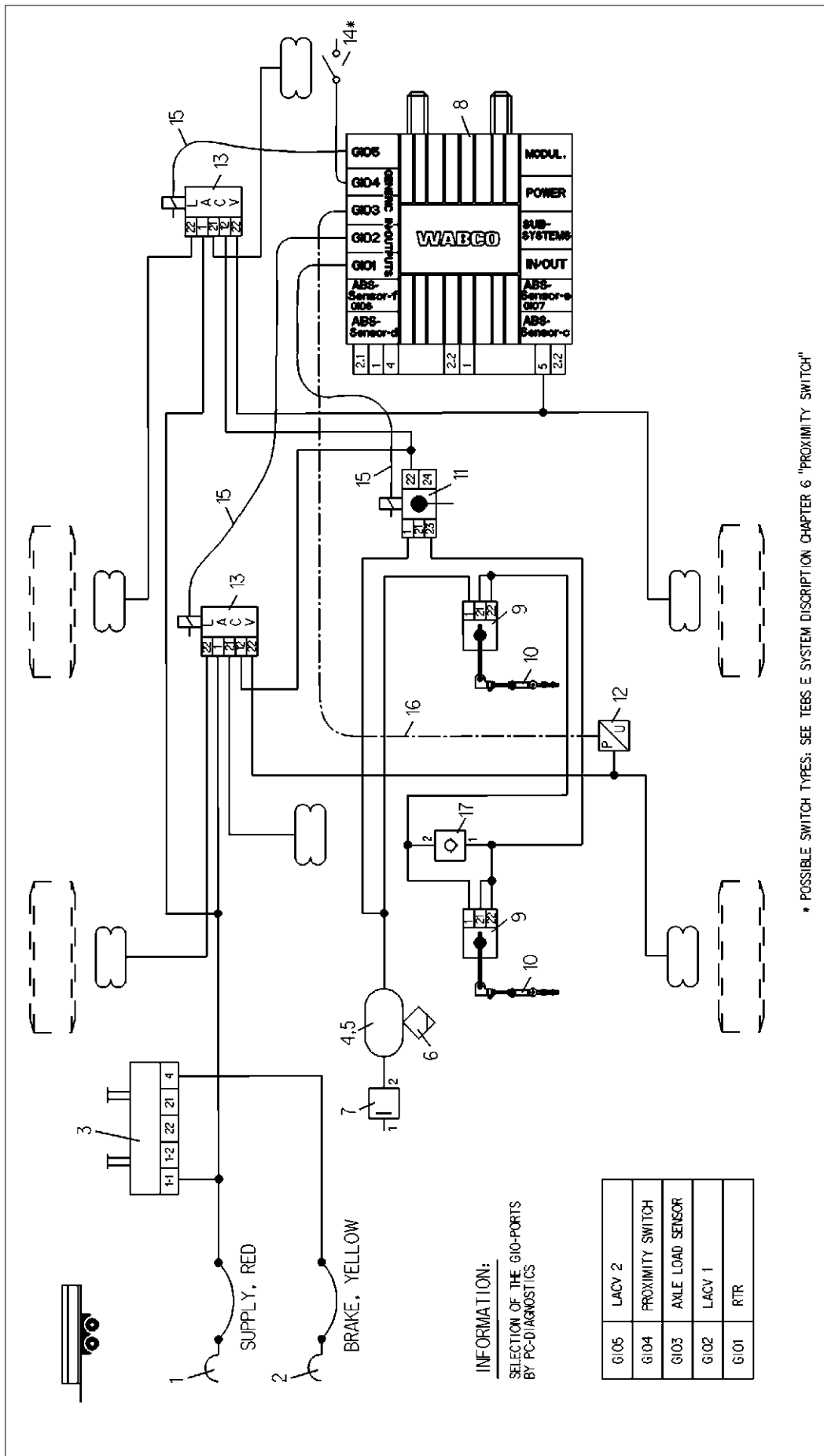

12	1	PRESSURE SENSOR	441 044 102 0					
11	1	ROTARY-SLIDE V. W. RTR-FUNCT. (TASC)	463 090 020 0					
10	2	PUSH ROD WITH LINKAGE	433 401 003 0					
9	2	LEVELLING VALVE	464 006 010 0					
8	1	TRAILER MODULATOR	480 102 ... 0					
7	1	CHARGING VALVE	434 100 ... 0					
6	1	DRAIN VALVE	934 300 001 0					
5	2	HOSE CLAMP	451 999 ... 2					
4	1	AIR RESERVOIR	950 0					
3	1	PARK-RELEASE-EMERG. VALVE (PREV)	971 002 9... 0					
2	1	COUPLING HEAD W. INT. LINE FILTER	952 201 ... 0					
1	1	COUPLING HEAD W. INT. LINE FILTER	952 201 ... 0					

Product Identification No.	434 014 000 0	434 535 ... 0	449 443 ... 0	TEB5 SYSTEM DISCR.	463 084 042 0
Denomination	CHECK VALVE	CABLE PRESSURE SENSOR	CABLE LIFT AXLE VALVE/RTR	PROXIMITY SWITCH	LIFT AXLE VALVE

17	1	CHECK VALVE	434 014 000 0		
16	1	CABLE PRESSURE SENSOR	434 535 ... 0		
15	3	CABLE LIFT AXLE VALVE/RTR	449 443 ... 0		
14	1	PROXIMITY SWITCH	TEB5 SYSTEM DISCR.		
13	2	LIFT AXLE VALVE	463 084 042 0		

Copyright WABCO®	Table	Signature	2013-11-27	2013-11-27	60MG	BURMESTER	1/3	CAU System	NO	1/3	434 014 000 0	434 535 ... 0	449 443 ... 0	TEB5 SYSTEM DISCR.	463 084 042 0
Drawn	2013-11-27	BURMESTER	Checked	2013-11-27	60MG	BURMESTER	1/3	CAU System	NO	1/3	434 014 000 0	434 535 ... 0	449 443 ... 0	TEB5 SYSTEM DISCR.	463 084 042 0
Scale	MATERIAL No.														
Eqpt	841 802 239 0														
Revision	A 3														
Techn. Resp.	4990														
Replacement for	002 EN 1/1														
Date of first issue: 2013-08-27															
Doc. Code															
Language															

ONE-CIRCUIT AIR SUSPENSION SYSTEMS AND TRACTION HELP MUST BE AGREED WITH THE AXLE MANUFACTURER
 § 97 / 27 / EG-DIRECTIVE MUST BE OBSERVED

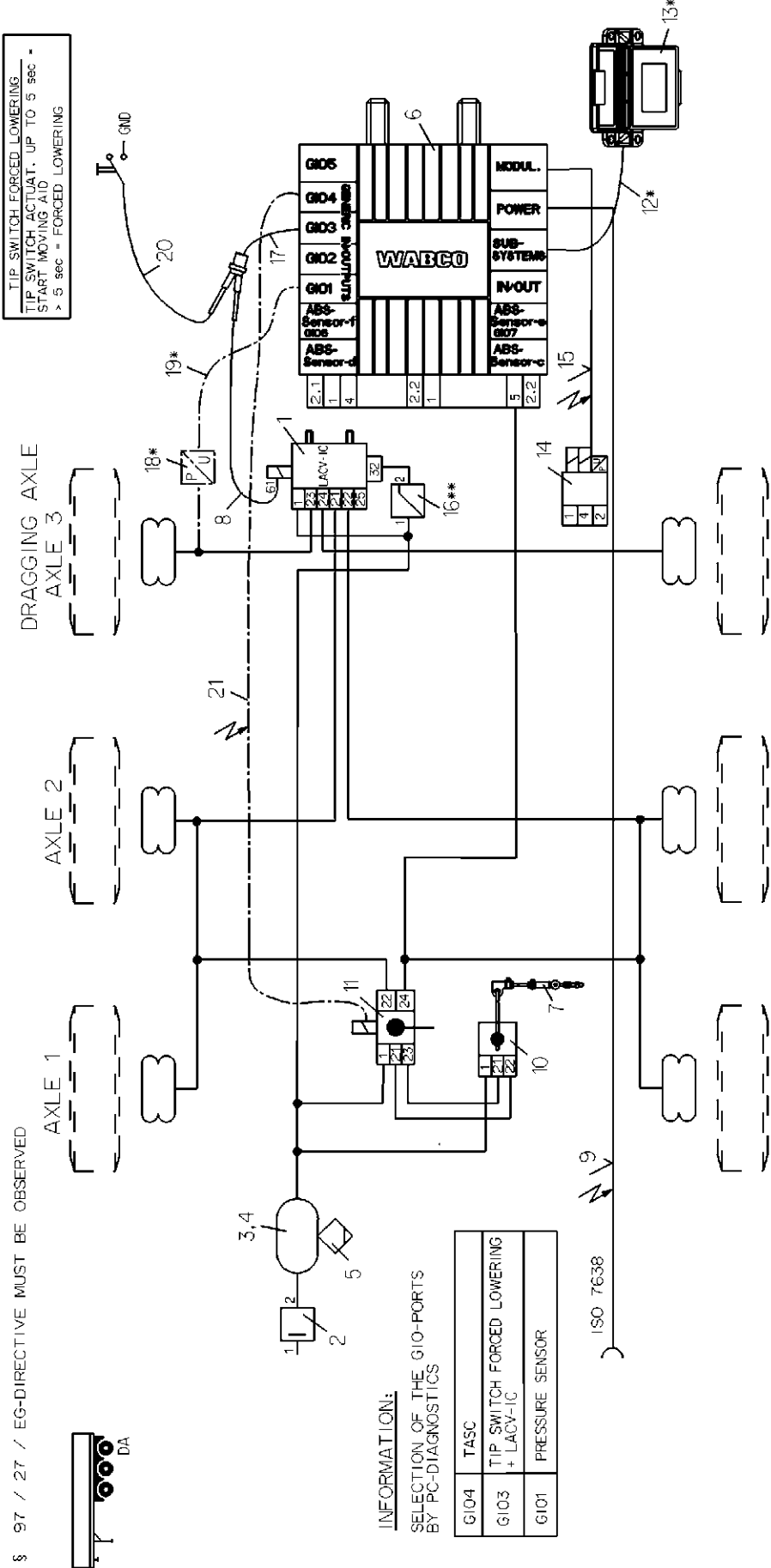

** OPTIONALLY STARTING FROM EBS E 2.0, RESIDUAL STRESS ATTITUDE CAN STARTING FROM E 2.0 WITH INTERNAL PARAMETERS REALIZES

12	1	CABLE SMART BOARD	*	449 911 ... 0				
11	1	TASC		463 090 00 0				
10	1	LEVELLING VALVE W/O HIGHT LIMITATION		464 006 002 0				
9	1	SUPPLY (POWER) CABLE		449 173 ... 0	21	1	CABLE FOR TASC	449 443 ... 0
8	1	IR-SWITCH CABLE A, LACV-IC CABLE		449 761 030 0	20	1	CABLE-FORCED LOWERING	449 718 ... 0
7	1	PUSH ROD WITH LINKAGE		433 401 003 0	19	1	CABLE TO PRESSURE SENSOR	* 449 812 ... 0
6	1	T-EBS E-MODULATOR		480 102 06 0	18	1	PRESSURE SENSOR	* 441 044 ... 0
5	1	DRAIN VALVE		934 300 003 0	17	1	CABLE-GIO Y-DISTRIBUTOR	449 629 000 0
4	2	HOSE CLAMP		451 999 ... 0	16	1	PRESSURE LIMITING VALVE	475 079 000 0
3	1	AIR RESERVOIR		950 ... 0	15	1	CABLE TO EBS-RV	449 429 ... 0
2	1	CHARGING VALVE		434 100 125 0	14	1	EBS-RELAY VALVE	480 207 ... 0
1	1	LACV-IC		463 084 100 0	13	1	SMART BOARD	* 446 192 110 0
Denomination				Product Identification No.	Pos.	Pcs.	Denomination	Product Identification No.
841 802 240 0				123925	E	4990		
TRAILER - EBS E1 PREMIUM								
FOR SEMITRAILER								
4S/3M, AIR SUSPENSION, LACV-IC								
DRAGGING AXLE, SMARTBOARD								
Date of first release: 07-09								
No. Code								
Language								
Sheet								
002								1/1
EN								
Replacement No.								

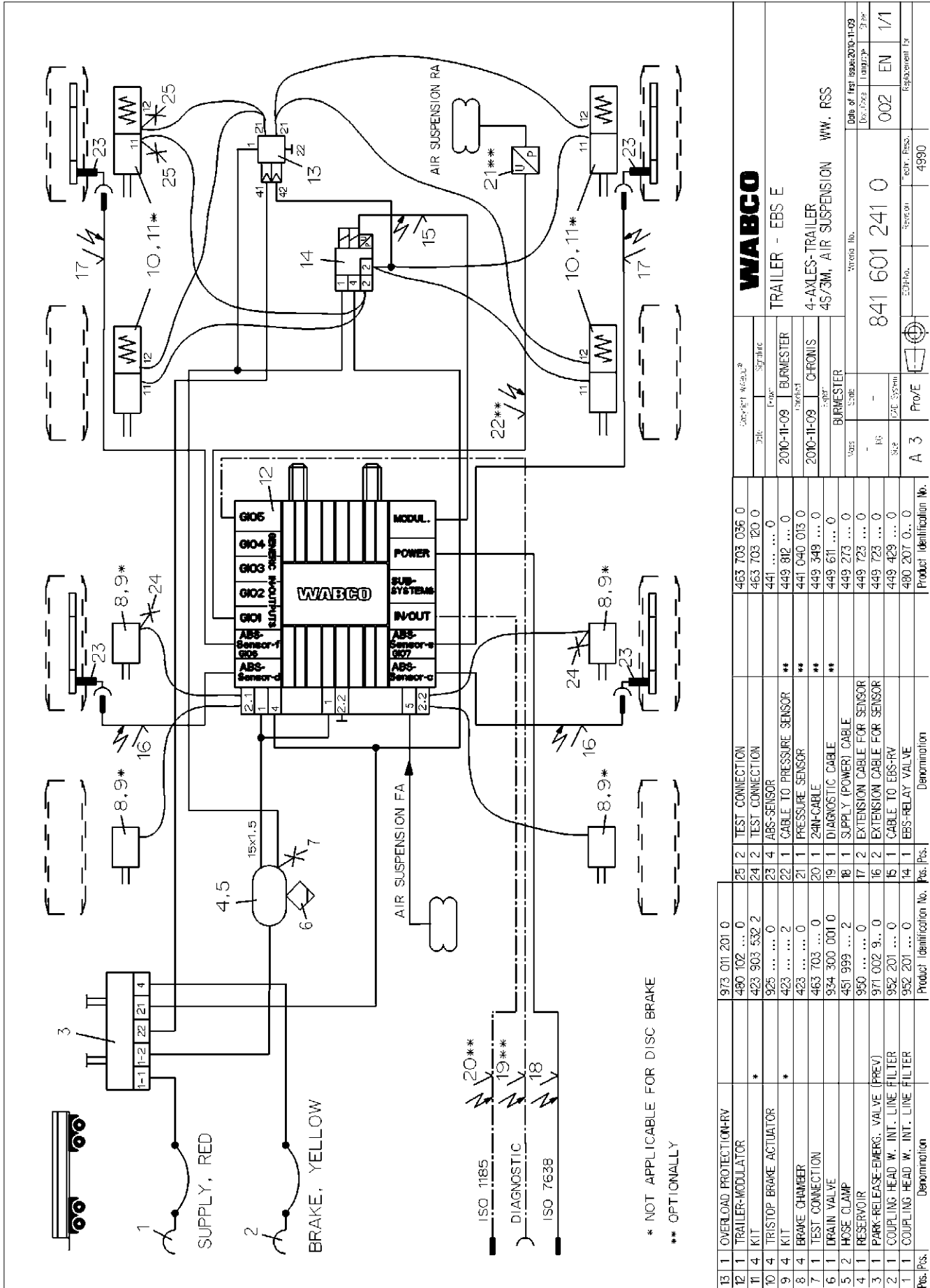

* NOT APPLICABLE FOR DISC BRAKE
 ** OPTIONALLY

Part No.		Description		Product Identification No.	
13	1	OVERLOAD PROTECTION/RV	973 011 201 0		
12	1	TRAILER-MODULATOR	480 102 ... 0	25	2
11	4	KIT	423 903 532 2	24	2
10	4	TRISTOP BRAKE ACTUATOR	925 0	23	4
9	4	KIT	423 2	22	1
8	4	BRAKE CHAMBER	423 0	21	1
7	1	TEST CONNECTION	463 703 ... 0	20	1
6	1	DRAIN VALVE	934 300 001 0	19	1
5	2	HOSE CLAMP	451 999 ... 2	18	1
4	1	RESERVOIR	950 0	17	2
3	1	PARK-RELEASE-EMERG. VALVE (PREV)	971 002 9... 0	16	2
2	1	COUPLING HEAD W. INT. LINE FILTER	952 201 ... 0	15	1
1	1	COUPLING HEAD W. INT. LINE FILTER	952 201 ... 0	14	1
Denomination		Product Identification No.		Denomination	
A 3		841 601 241 0		4990	

WABCO	
TRAILER - EBS E	
4-AXLES-TRAILER	
4S/3M, AIR SUSPENSION WW, RSS	
Part No.	841 601 241 0
Rev. No.	002
Lang. Code	EN
Date of first issue	2010-11-09

Doc. No.	841 601 241 0
Rev. No.	002
Lang. Code	EN
Date of first issue	2010-11-09

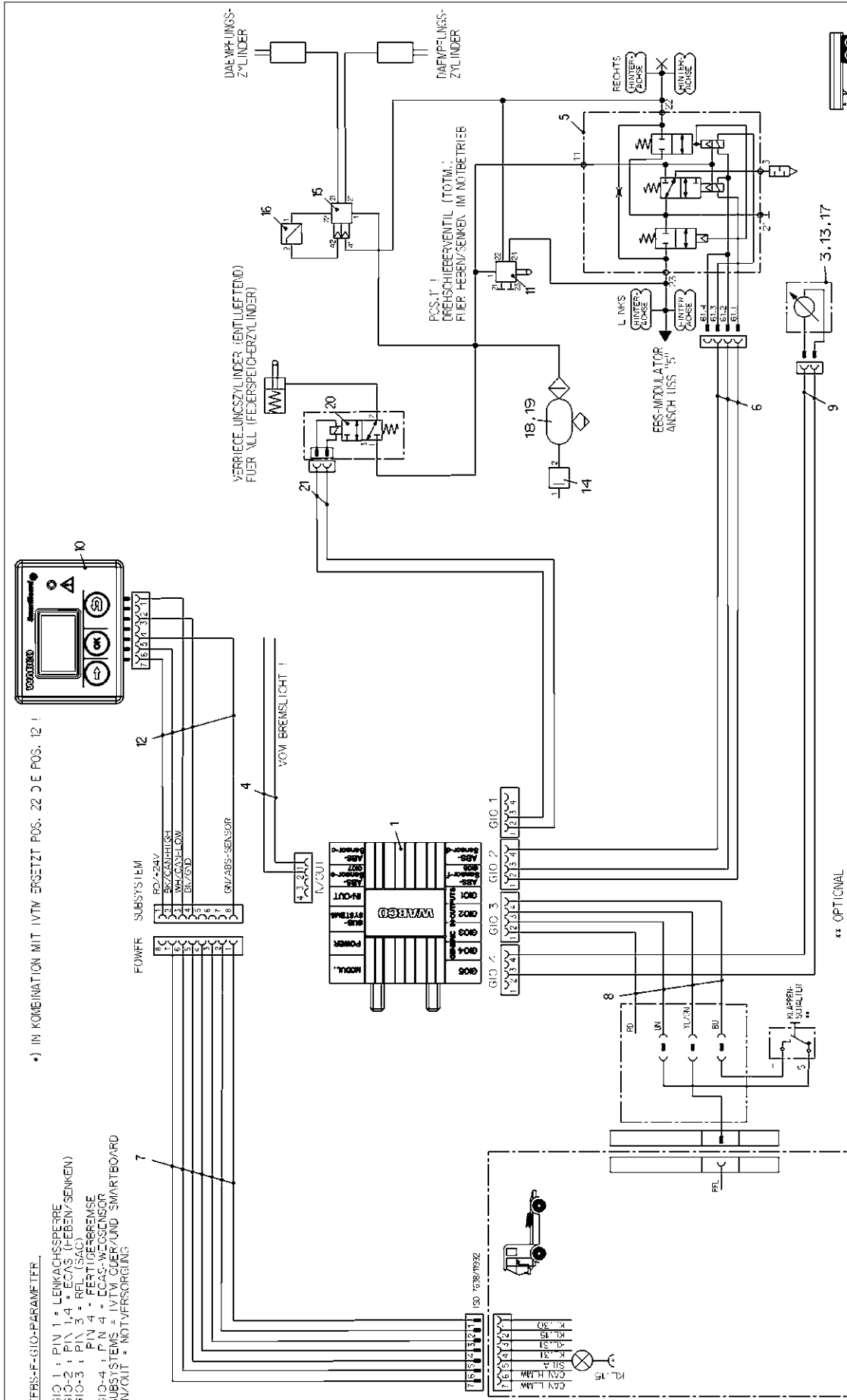

*) IN KOMBINATION MIT 1VTW ERSETZT POS. 22 DE POS. 12 !

VERKABELUNGSSCHHEMA

WABCO

2009-09-26

2009-09-26

841 802 244 0

002 DE V1

4990

23778

4990

WABCO

VERKABELUNGSSCHHEMA

2009-09-26

2009-09-26

841 802 244 0

002 DE V1

4990

23778

4990

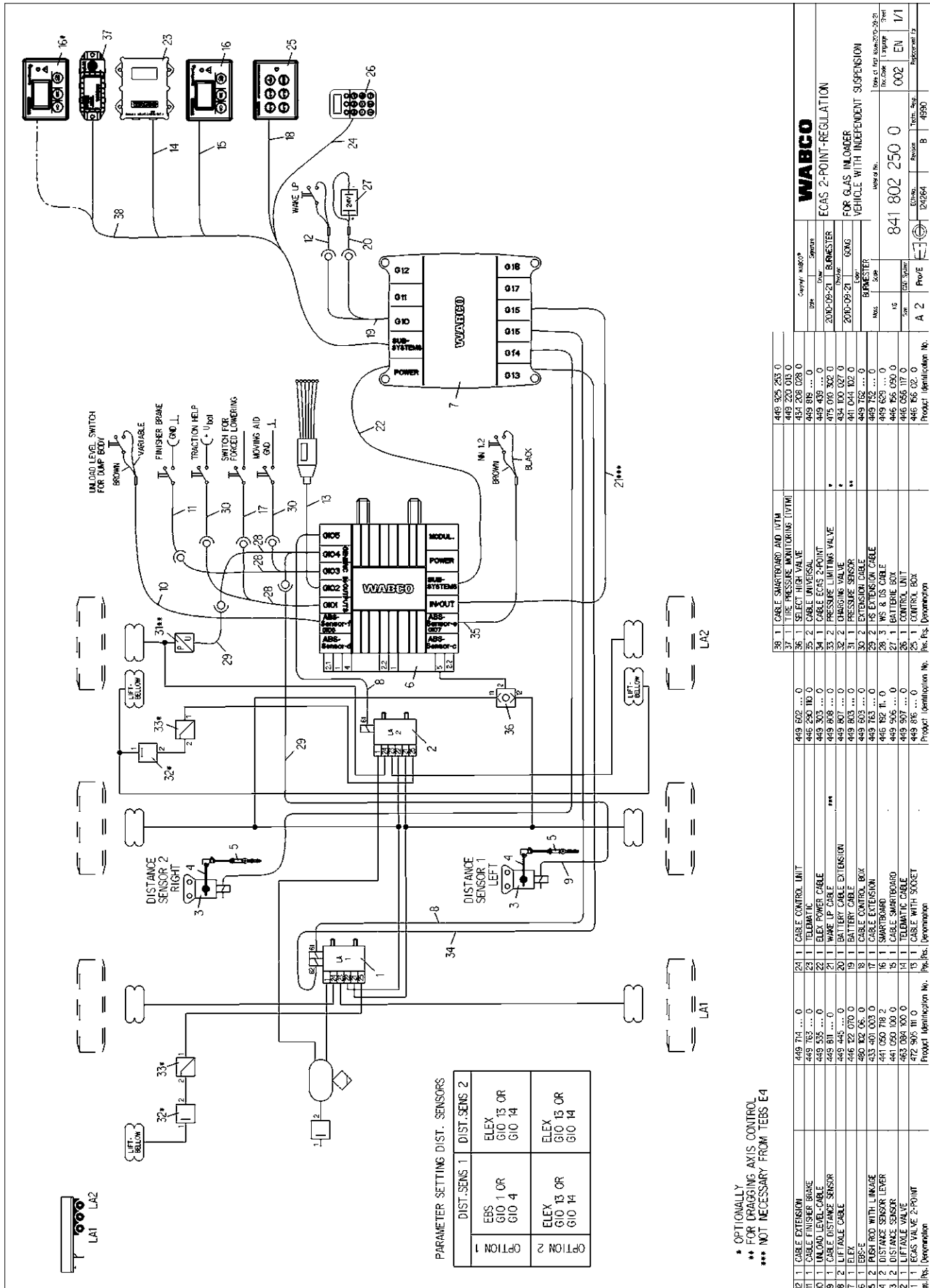

PARAMETER SETTING DIST. SENSORS

DIST.SENS 1	DIST.SENS 2
EBS GIO 1 OR GIO 4	ELEX GIO 13 OR GIO 14
OPTION 2	ELEY GIO 13 OR GIO 14

* OPTIONALLY
 ** FOR DRAGGING AXIS CONTROL
 *** NOT NECESSARY FROM TEB5 E4

No.	Description	Qty.	Part No.	Dependent
12	1	1	449 714 ... 0	24
13	1	1	449 763 ... 0	23
14	1	1	449 535 ... 0	22
15	1	1	449 811 ... 0	21
16	1	1	449 445 ... 0	20
17	1	1	446 822 070 0	19
18	1	1	449 803 ... 0	18
19	1	1	449 763 ... 0	17
20	1	1	449 714 ... 0	16
21	1	1	441 650 100 0	15
22	1	1	449 505 ... 0	14
23	1	1	449 505 ... 0	13
24	1	1	449 811 ... 0	12
25	1	1	449 811 ... 0	11
26	1	1	449 811 ... 0	10
27	1	1	449 811 ... 0	9
28	1	1	449 811 ... 0	8
29	1	1	449 811 ... 0	7
30	1	1	449 811 ... 0	6
31	1	1	449 811 ... 0	5
32	1	1	449 811 ... 0	4
33	1	1	449 811 ... 0	3
34	1	1	449 811 ... 0	2
35	1	1	449 811 ... 0	1
36	1	1	449 811 ... 0	0
37	1	1	449 811 ... 0	0
38	1	1	449 811 ... 0	0

841 802 252 0

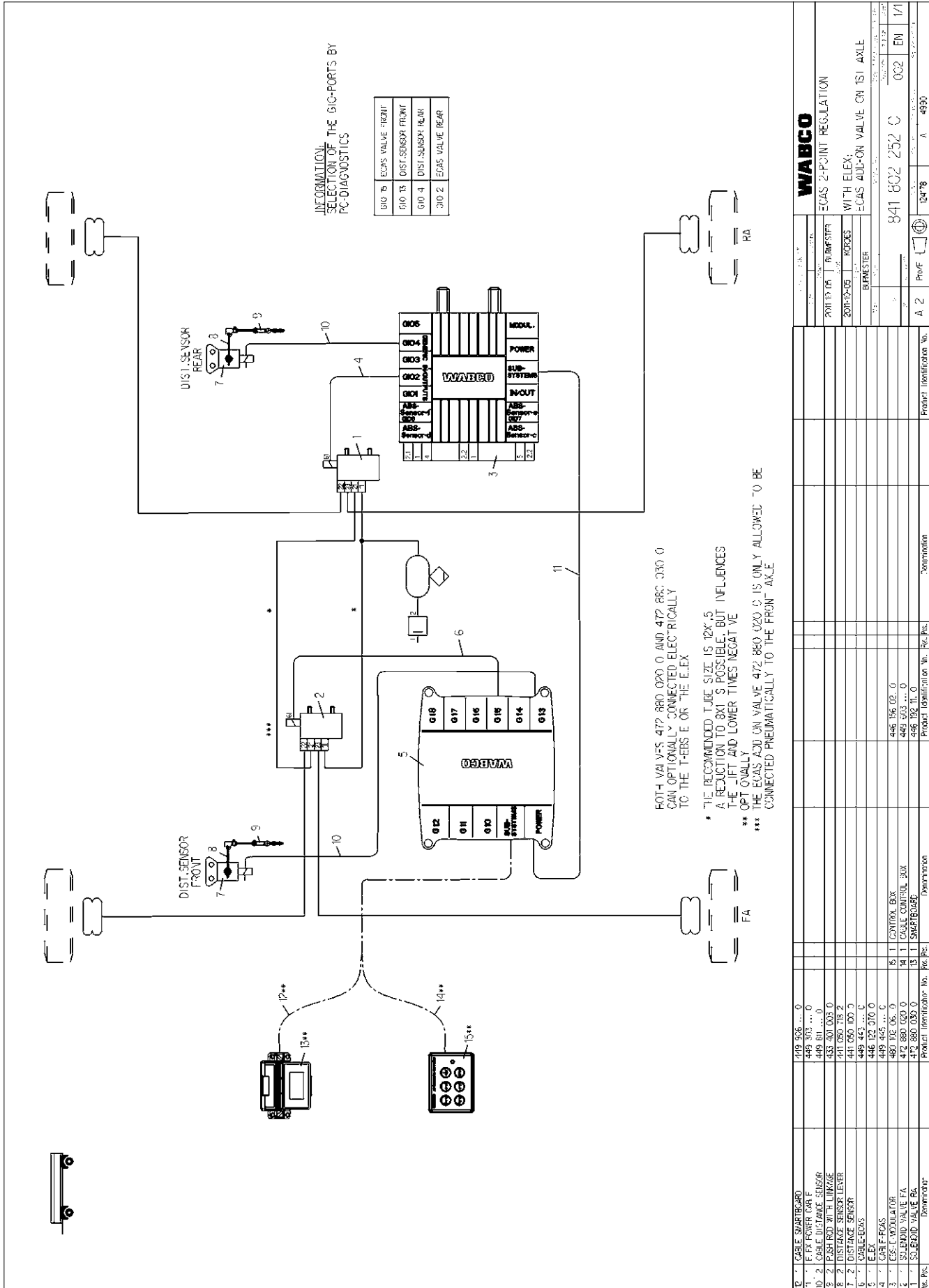

WABCO	
ECAS 2-POINT REGULATION	
20110301	REVISION
20110305	REVISION
WITH E-LEX: ECAS ADD-ON VALVE ON 1ST AXLE	
841 802 252 0	
A 2	PROF
0478	REV
A	0990
Product Identification No.	
Part No.	
Description	
119 306 ... 0	CABLE SHARBOARD
449 307 ... 0	1 - FX POWER BAR F
449 801 ... 0	2 - CABLE DISTANCE SENSOR
435 301 003 0	3 - PUSH ROD WITH LINKAGE
111 050 718 2	4 - DISTANCE SENSOR LEVER
441 050 100 0	5 - DISTANCE SENSOR
449 442 ... 0	6 - E-LEX
446 122 070 0	7 - CABLE-ECAS
449 445 ... 0	8 - CABLE-ECAS
480 302 06 0	9 - E-LE-VALVE/RELAY
472 880 030 0	10 - SOLENOID VALVE FA
472 880 020 0	11 - SOLENOID VALVE RA
Product Identification No.	
Part No.	
Description	

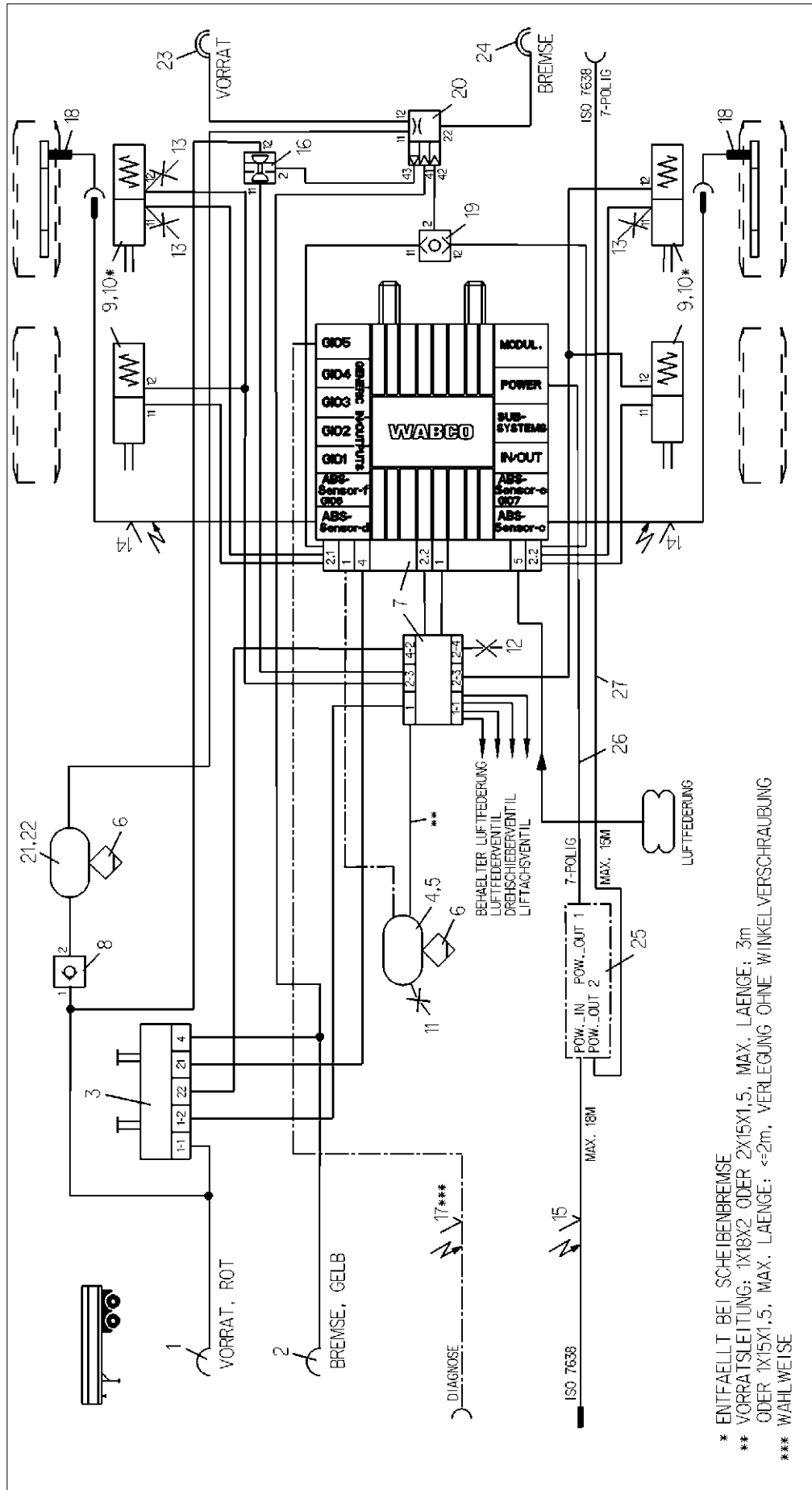

* ENTFALLT BEI SCHEIBENBREMSE
 ** VORRATSLAUFLEITUNG: 1X18X2 ODER 2X15X1,5, MAX. LAENGE: 3m
 ODER 1X15X1,5, MAX. LAENGE: <2m, VERLEGUNG OHNE WINKELVERSCHAUBUNG
 *** WAHLWEISE

Pos. / Pos.	Denomination	Product identification No.	Pos. / Pos.	Denomination	Product identification No.
14 2	VERLAENGERUNGSKABEL FUER SENSOR	449 723 ... 0	28		
13 3	PRUEFANSCHLUSS	463 703 036 0	27 1	VERSORGUNGSKABEL	449 135 ... 0
12 1	PRUEFANSCHLUSS	463 703 120 0	26 1	VERSORGUNGSKABEL	449 347 ... 0
11 1	PRUEFANSCHLUSS	463 703 115 0	25 1	CAN-ROUTER	446 122 050 0
10 4	BEIPACK	* 423 903 532 2	24 1	KUPPLUNGSKOPF AUTOM. BREMSE	962 200 222 0
9 4	TRISTOPZYLINDER	925 ... 0	23 1	KUPPLUNGSKOPF AUTOM. VORRAT	962 200 221 0
8 1	RUECKSCHLAGVENTIL	434 014 000 0	22 2	SPANNBAND	451 999 ... 2
7 1	AH-Modulator MAXENSION MODUL	480 102 ... 0	21 1	LUFTBEHAELTER	960 ... 0
6 2	ENTWAESSERUNGSVENTIL	934 300 001 0	20 1	AH-STEUERVENTIL	973 ... 0
5 2	SPANNBAND	451 999 ... 2	19 1	ZWEIWEVENTIL	434 208 02 0
4 1	LUFTBEHAELTER	950 ... 0	18 2	ABS-SENSOR	441 032 8.. 0
3 1	PARK-LOESE-SICHERH.-VENT. (PREV)	971 002 9.. 0	17 1	DIAGNOSKABEL	*** 449 611 ... 0
2 1	KUPPLUNGSKOPF M. INT. LEITUNGSFILTER	952 201 ... 0	16 1	DUPPEL ABS-FERVENTIL	434 500 003 0
1 1	KUPPLUNGSKOPF M. INT. LEITUNGSFILTER	952 201 ... 0	15 1	VERSORGUNGSKABEL	449 133 ... 0

WABCO
 TRAILER - EBS E
 FUER 2-ACHS-SATTELANFAEHRER
 MIT CAN-ROUTER
 2S/2M

WABCO No. 841 701 271 0
 Date of first issue: 2012-07-11
 Rev. 002 DE 1/1

Part No. 841 701 271 0
 Part. Res. 4990

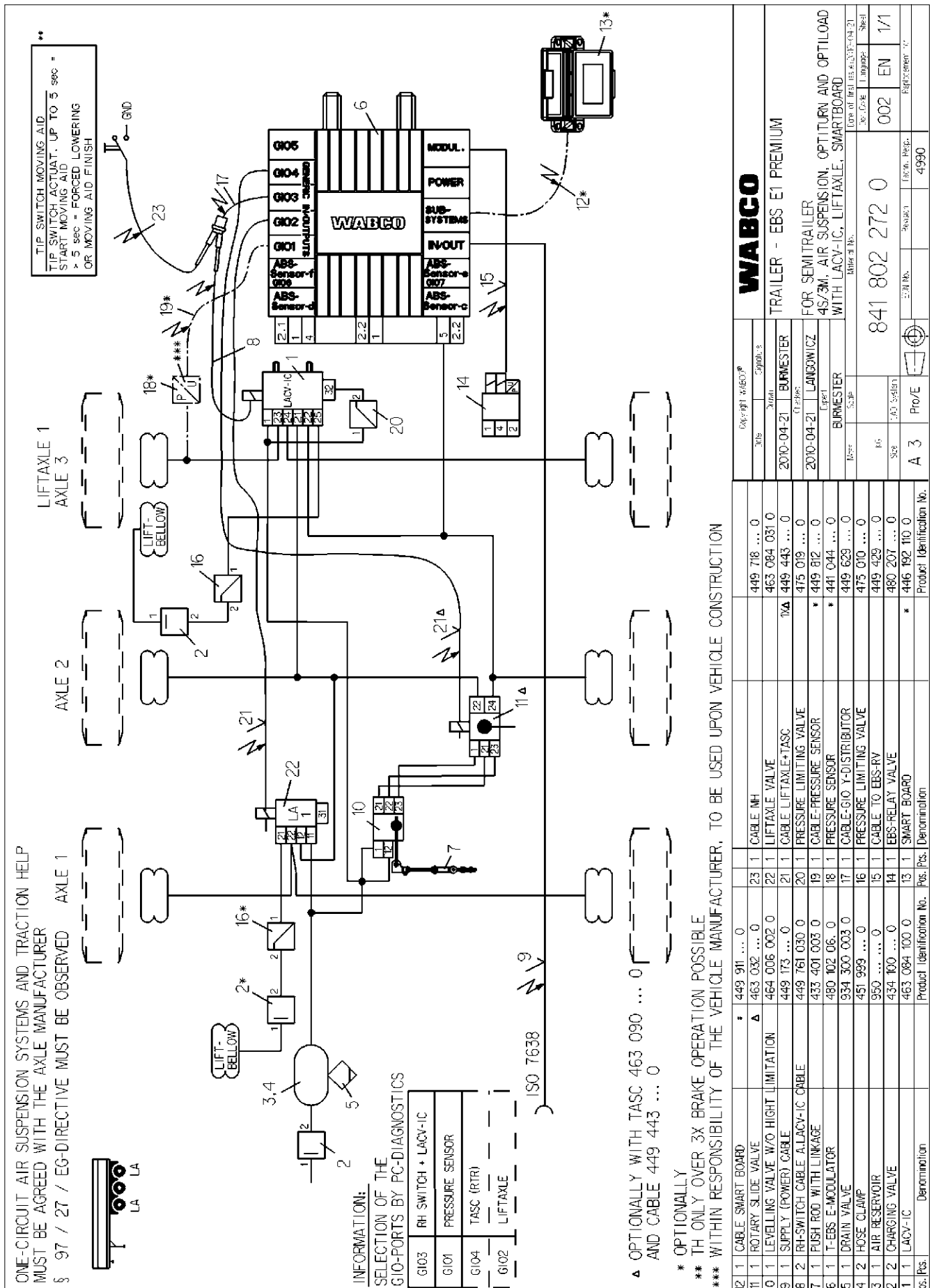

Cable No.		Signal	
2010-04-21		BURMESTER	
2010-04-21		LANGOWICZ	
BURMESTER		BURMESTER	
Date of first release: 07.04.21			
Part No.		Part. No.	
841 802 272 0		4990	
Revision		Revision	
002		EN 1/1	
Language		Shell	

Pos.	Denomination	Pos.	Denomination
12	1 CABLE SMART BOARD	11	1 CABLE MH
11	1 ROTARY SLIDE VALVE	23	1 CABLE MH
10	1 LEVELLING VALVE W/O HEIGHT LIMITATION	22	1 LIFTAXLE VALVE
9	1 SUPPLY (POWER) CABLE	21	1 CABLE LIFTAXLE+TASC
8	2 RH-SWITCH CABLE-A.LACV-IC CABLE	20	1 PRESSURE LIMITING VALVE
7	1 PUSH ROD WITH LINKAGE	19	1 CABLE-PRESSURE SENSOR
6	1 T-EBS E-MODULATOR	18	1 PRESSURE SENSOR
5	1 DRAIN VALVE	17	1 CABLE-GIO Y-DISTRIBUTOR
4	2 HOSE CLAMP	16	1 PRESSURE LIMITING VALVE
3	1 AIR RESERVOIR	15	1 CABLE TO EBS-RV
2	2 CHARGING VALVE	14	1 EBS-RELAY VALVE
1	1 LACV-IC	13	1 SMART BOARD

841 802 274 0

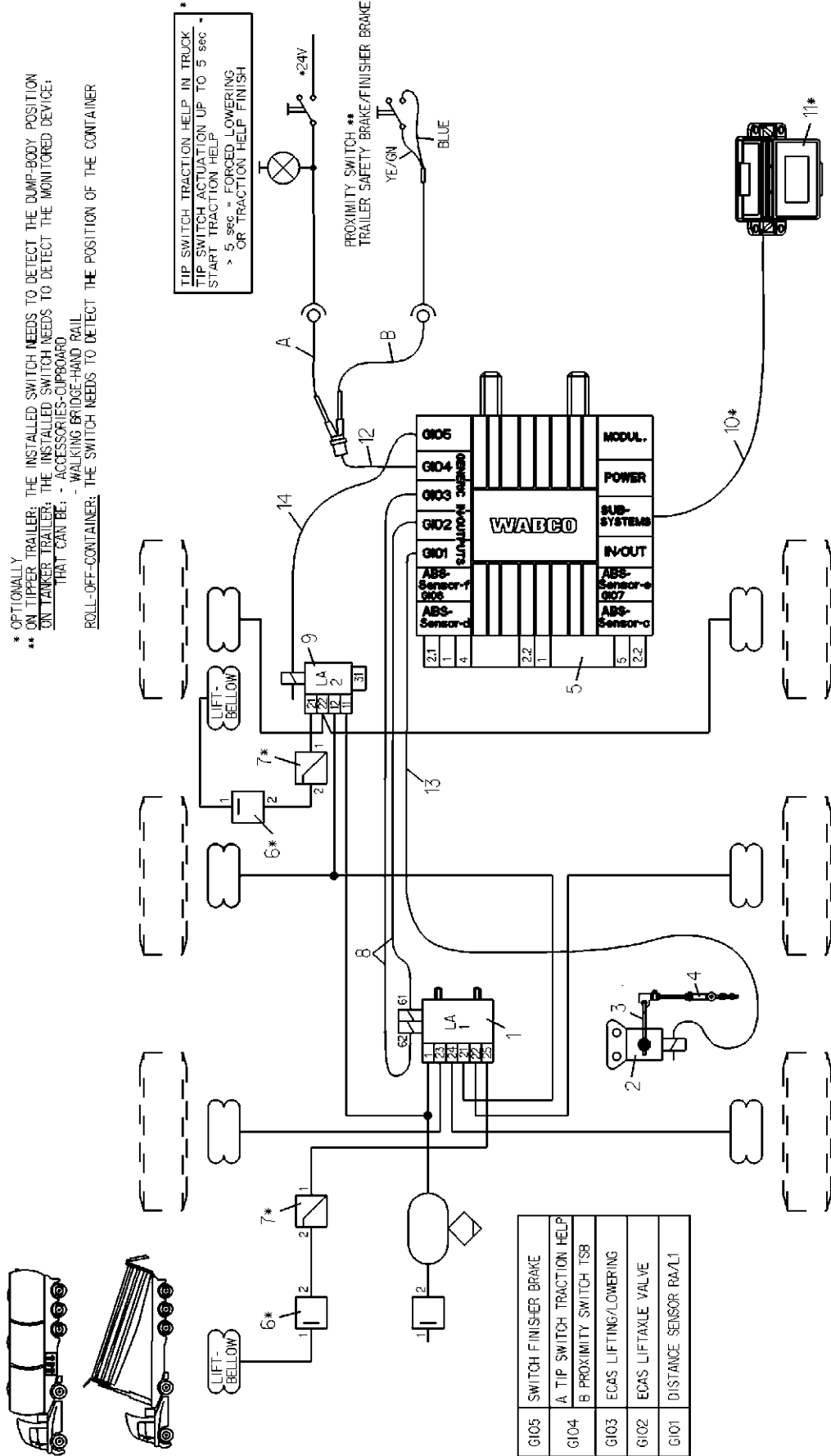

<p>WABCO</p> <p>TRAILER - EBS E FOR SEMITRAILER WITH TRAILER SAFETY BRAKE AND ECAS</p>		<p>Doc. Code: 411.3.002</p> <p>Date of first issue: 2015-02-06</p>	
<p>841 802 274 0</p>		<p>EN 1/1</p>	
<p>4990</p>		<p>4990</p>	

12	1	Y-CONNECTOR	449 629 000 0		
11	1	SMART BOARD	446 182 110 0		
10	1	CABLE-SMART BOARD	449 911 000 0		
9	1	LIFTAXLE VALVE	463 084 ... 0		
8	2	CABLE-LIFTAXLE/ECAS	449 445 000 0		
7	2	PRESSURE LIMITING VALVE	475 0		
6	2	CHARGING VALVE	434 0		
5	1	T-EBS E-MODULATOR	480 102 ... 0		
4	1	PUSH ROD WITH LINKAGE	433 401 003 0		
3	1	DISTANCE SENSOR LEVER	441 050 718 2		
2	1	DISTANCE SENSOR	441 050 100 0	14	1
1	1	ECAS-BLOCK	472 905 114 0	13	1

Pos. Pts.	Denomination	Product Identification No.	Pos. Pts.	Denomination	Product Identification No.

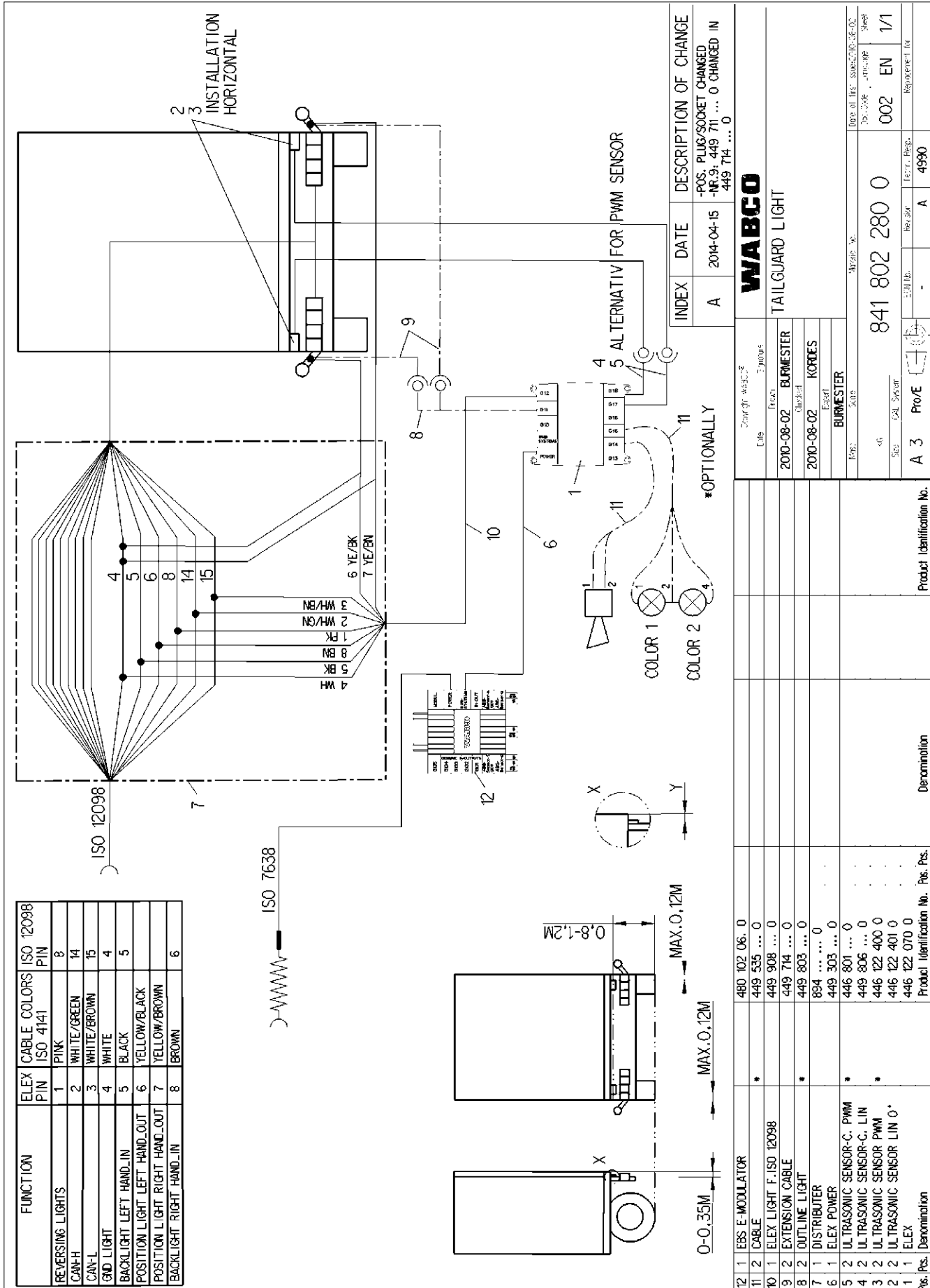

INDEX	DATE	DESCRIPTION OF CHANGE
A	2014-04-15	-POS. PLUS/sockets CHANGED -NR.9, 449 711 ... 0 CHANGED IN 449 714 ... 0

WABCO		
TAILGUARD LIGHT		
2010-08-02	BURMESTER	
2010-08-02	KORRES	
BURMESTER		
841 802 280 0		
002	EN	1/1

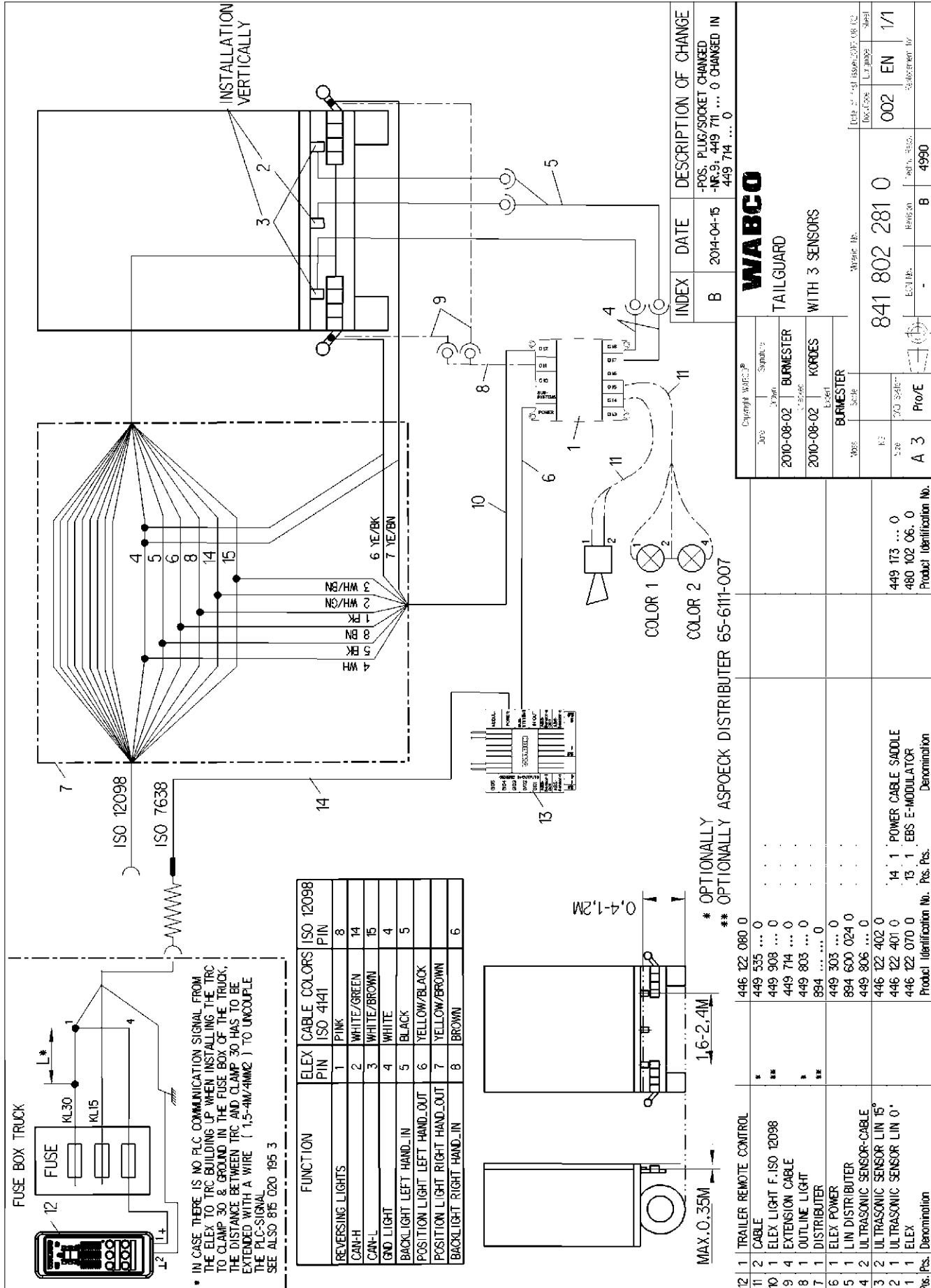

IN CASE THERE IS NO PLC COMMUNICATION SIGNAL FROM THE ELEX TO TRC BUILDING UP WHEN INSTALLING THE TRC TO CLAMP 30 & GROUND IN THE FUSE BOX OF THE TRUCK, THE DISTANCE BETWEEN TRC AND CLAMP 30 HAS TO BE EXTENDED WITH A WIRE (1,5-4M/4MM2) TO UNCOUPLE THE PLC-SIGNAL
SEE ALSO 815 020 195 3

FUNCTION	ELEX CABLE COLORS	ISO 4141	ISO 12098
	PIN	PIN	PIN
REVERSING LIGHTS	1	PINK	8
CAN-H	2	WHITE/GREEN	14
CAN-L	3	WHITE/BROWN	15
GND LIGHT	4	WHITE	4
BACKLIGHT LEFT HAND..IN	5	BLACK	5
POSITION LIGHT LEFT HAND..OUT	6	YELLOW/BLACK	
POSITION LIGHT RIGHT HAND..OUT	7	YELLOW/BROWN	
BACKLIGHT RIGHT HAND..IN	8	BROWN	6

* OPTIONALLY
** OPTIONALLY ASPOECK DISTRIBUTER 65-6111-007

Copyright WABCO® Date: 2010-08-02 Status: BURMESTER Version: 1.0 Part No.: 841 802 281 0 Description: TAILGUARD WITH 3 SENSORS		INDEX: B DATE: 2014-04-15 DESCRIPTION OF CHANGE: -POS. PLUG/SOCKET CHANGED -NR.9, 449 711 ... 0 CHANGED IN 449 714 ... 0
Part No.: 841 802 281 0 Description: TAILGUARD WITH 3 SENSORS Revision: B Date: 2014-04-15 Author: EN 1/1 Checked: EN 1/1 Drawn: EN 1/1 Approved: EN 1/1		Part No.: 841 802 281 0 Description: TAILGUARD WITH 3 SENSORS Revision: B Date: 2014-04-15 Author: EN 1/1 Checked: EN 1/1 Drawn: EN 1/1 Approved: EN 1/1
Part No.: 841 802 281 0 Description: TAILGUARD WITH 3 SENSORS Revision: B Date: 2014-04-15 Author: EN 1/1 Checked: EN 1/1 Drawn: EN 1/1 Approved: EN 1/1		Part No.: 841 802 281 0 Description: TAILGUARD WITH 3 SENSORS Revision: B Date: 2014-04-15 Author: EN 1/1 Checked: EN 1/1 Drawn: EN 1/1 Approved: EN 1/1

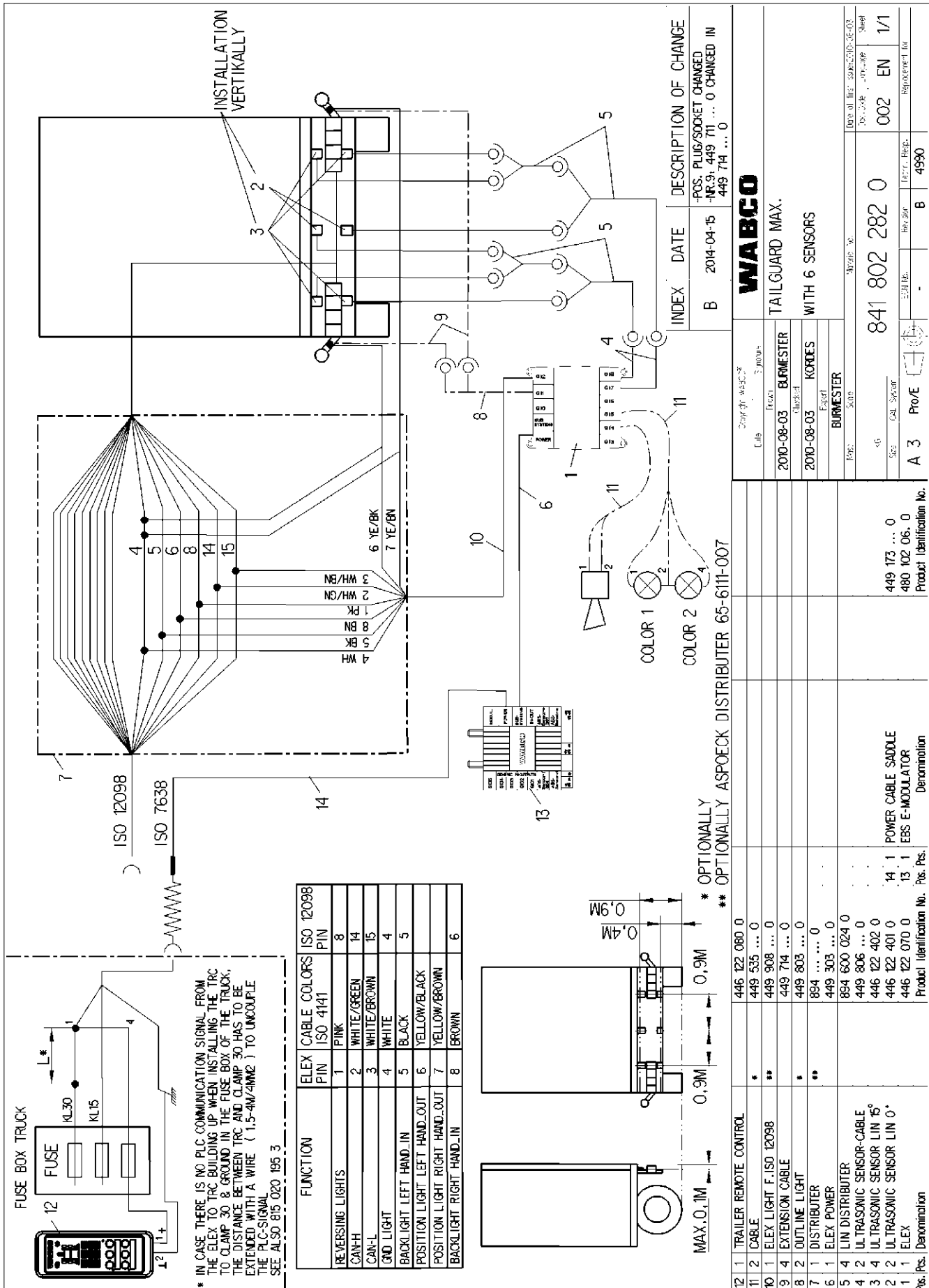

INDEX	DATE	DESCRIPTION OF CHANGE
B	2014-04-15	-POS. PLUG/SOCKET CHANGED -NR.9, 449 714 ... 0 CHANGED IN 449 714 ... 0

WABCO

TAILGUARD MAX.
WITH 6 SENSORS

2010-08-03 BURMESTER
2010-08-03 KORDES
BURMESTER

Part No. 841 802 282 0

Rev. 300 B

449 173 ... 0
480 102 06 ... 0

Product Identification No. Denomination

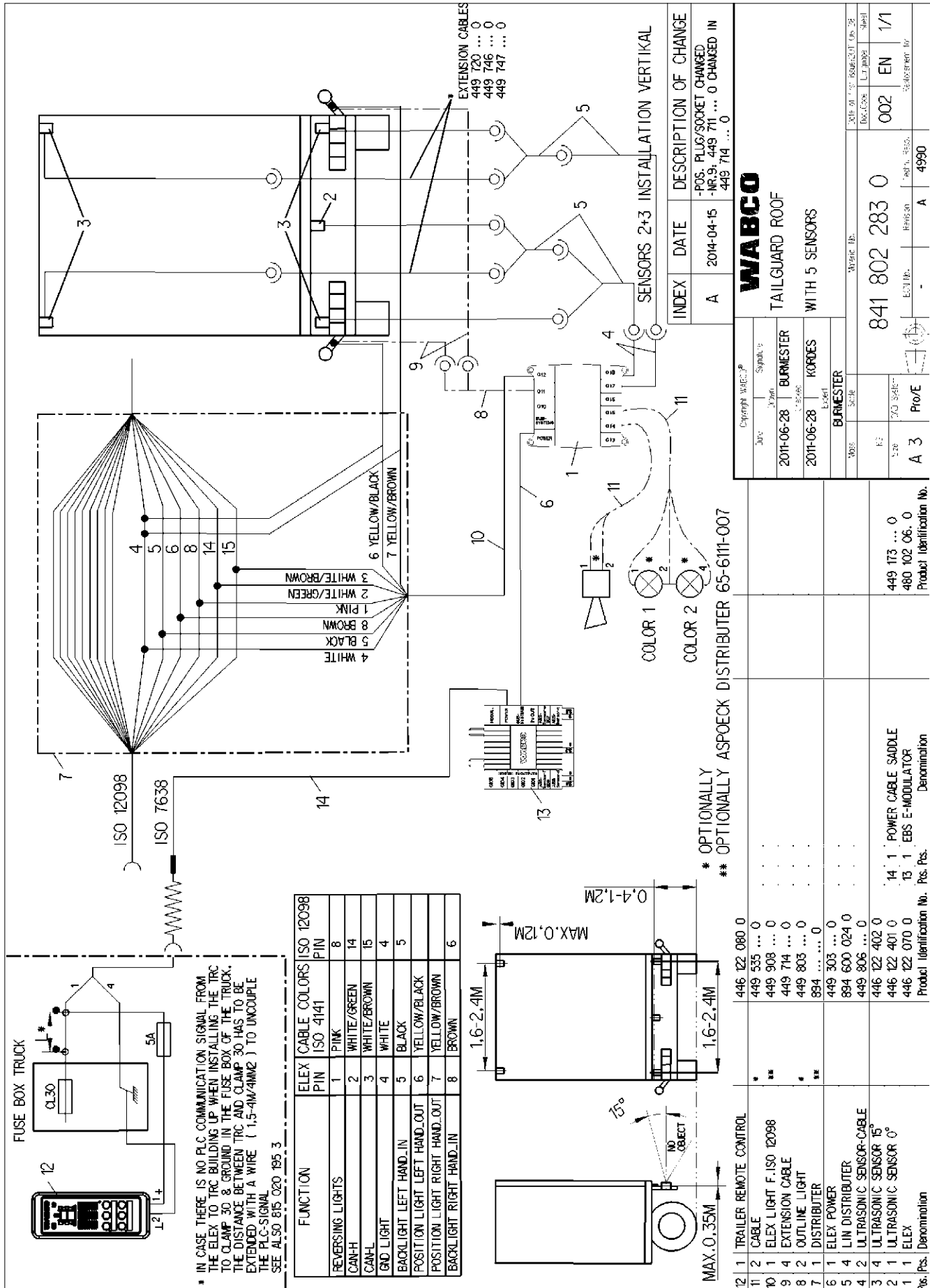

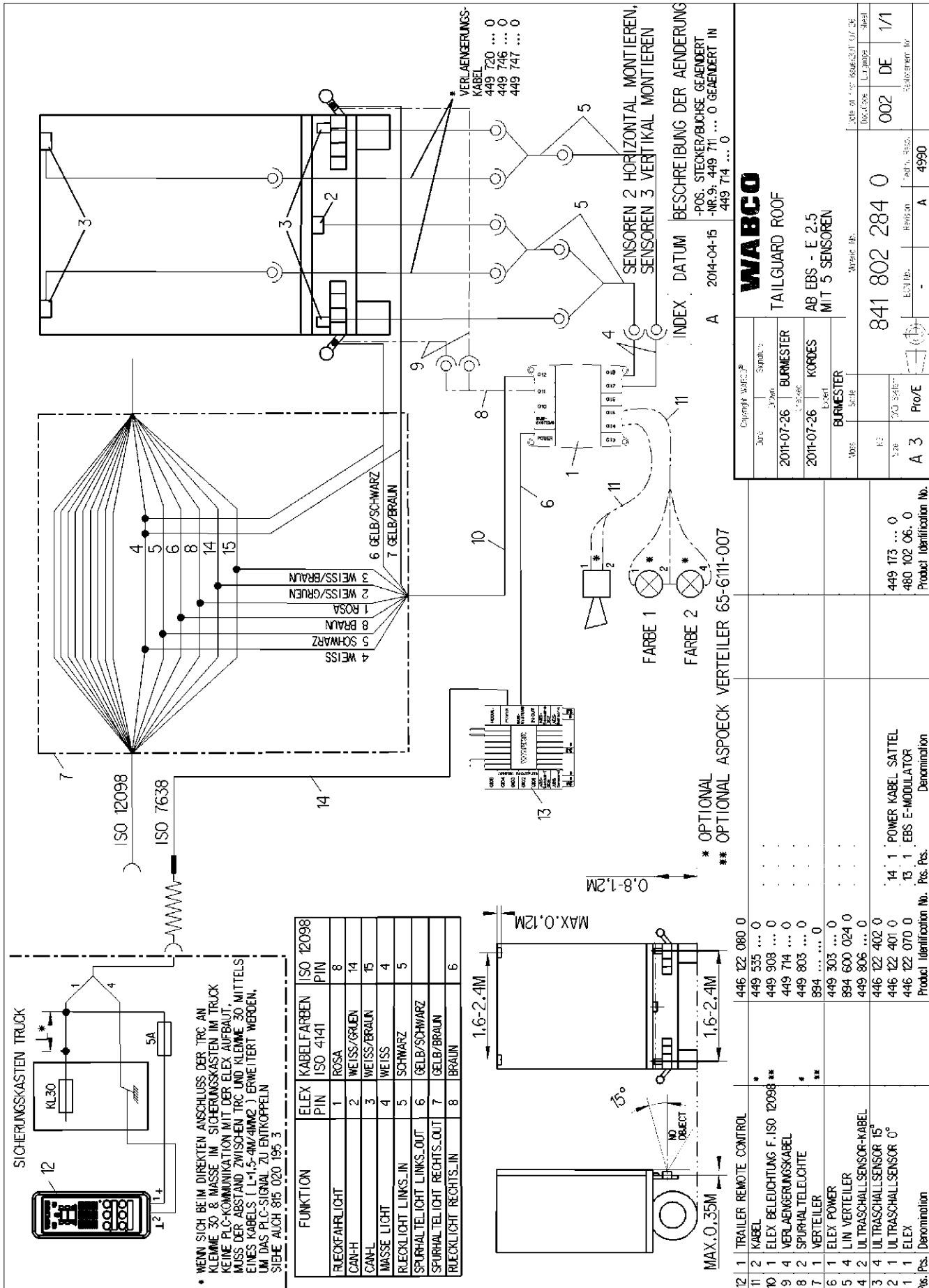

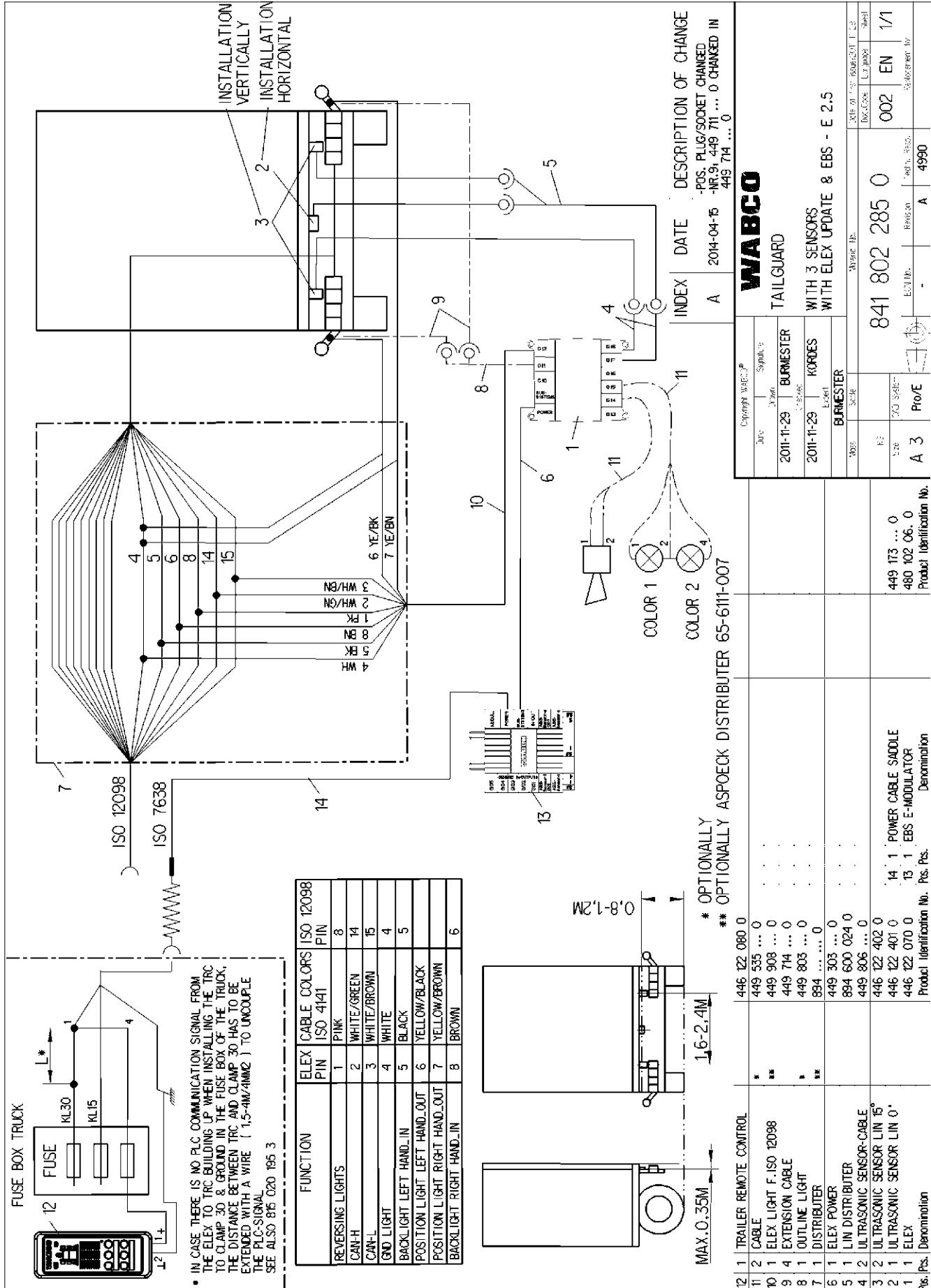

• IN CASE THERE IS NO PLC COMMUNICATION SIGNAL FROM THE ELEX TO TRC BUILDING UP WHEN INSTALLING THE TRC TO CLAMP 30 & GROUND IN THE FUSE BOX OF THE TRUCK, THE DISTANCE BETWEEN TRC AND CLAMP 30 HAS TO BE EXTENDED WITH A WIRE (1,5-4M/4MM²) TO UNCOUPLE THE PLC-SIGNAL
SEE ALSO 816 020 195 3

FUNCTION	ELEX PIN	CABLE COLORS ISO 4141	ISO 12098 PIN
REVERSING LIGHTS	1	PINK	8
CAN-H	2	WHITE/GREEN	14
CAN-L	3	WHITE/BROWN	15
GNL LIGHT	4	WHITE	4
BACKLIGHT LEFT HAND-IN	5	BLACK	5
POSITION LIGHT LEFT HAND-OUT	6	YELLOW/BLACK	
POSITION LIGHT RIGHT HAND-OUT	7	YELLOW/BROWN	
BACKLIGHT RIGHT HAND-IN	8	BROWN	6

* OPTIONALLY
** OPTIONALLY ASPOECK DISTRIBUTER 65-6111-007

INDEX DATE DESCRIPTION OF CHANGE
A 2014-04-15 -POS. PLUG/SOCKET CHANGED
-NR.9, 449 711 ... 0 CHANGED IN
449 714 ... 0

WABCO
TAILGUARD
WITH 3 SENSORS
WITH ELEX UPDATE & EBS - E 2.5

Doc. Code	841 802 285 0	Rev. Code	002	EN	1/1
Doc. Title	841 802 285 0				
Doc. No.	841 802 285 0				
Doc. Rev.	002				
Doc. Issue Date	2014-04-15				
Doc. Issue No.	4990				

Pos.	Denomination	Product Identification No.	Pos.	Denomination	Product Identification No.
12	TRAILER REMOTE CONTROL	446 122 080 0	14	POWER CABLE SADDLE	449 173 ... 0
11	CABLE	449 535 ... 0	13	EBS E-MODULATOR	480 102 06. 0
10	ELEX LIGHT F.ISO 12098	449 908 ... 0			
9	EXTENSION CABLE	449 714 ... 0			
8	OUTLINE LIGHT	449 803 ... 0			
7	DISTRIBUTER	894 ... 0			
6	ELEX POWER	449 303 ... 0			
5	LINE DISTRIBUTER	894 600 024 0			
4	ULTRASONIC SENSOR-CABLE	449 806 ... 0			
3	ULTRASONIC SENSOR LIN 15°	446 122 402 0			
2	ULTRASONIC SENSOR LIN 0°	446 122 401 0			
1	ELEX	446 122 070 0			

ONE-CIRCUIT AIR SUSPENSION SYSTEMS AND TRACTION HELP MUST BE AGREED WITH THE AXLE MANUFACTURER § 97 / 27 / EG-DIRECTIVE MUST BE OBSERVED

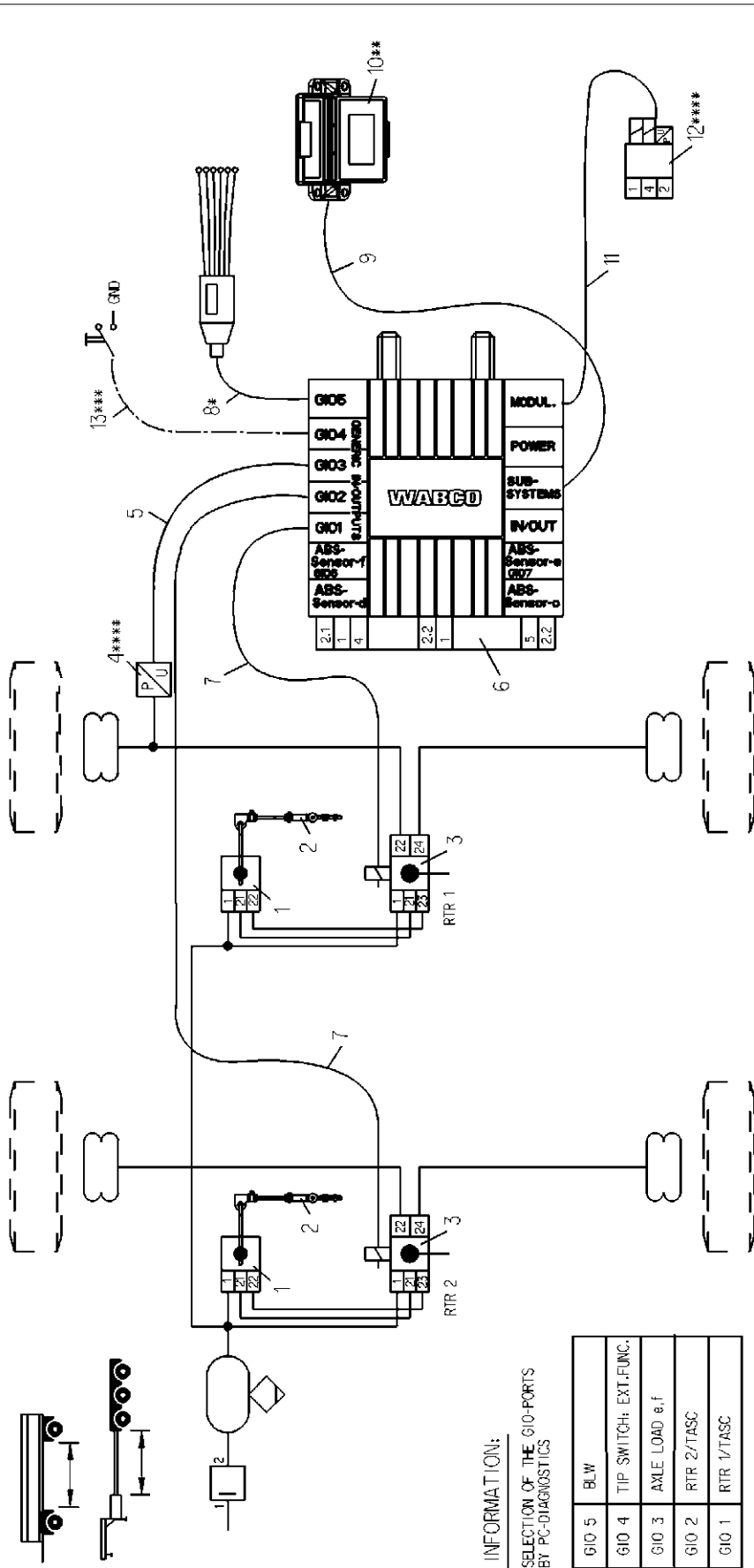

INFORMATION:

SELECTION OF THE GIO-PORTS BY PC-DIAGNOSTICS

GIO 5	BLW
GIO 4	TIP SWITCH; EXT-FUNC.
GIO 3	AXLE LOAD e.f
GIO 2	RTR 2/TASC
GIO 1	RTR 1/TASC

* OPTIONALLY
** ACTIVATION OF "TRAILER EXTENDING CONTROL" WITH SMARTBOARD REQUIRED
*** OPTIONALLY; SWITCH FOR ACTIVATION OF "TRAILER EXTENDING CONTROL"
**** FOR DRAWBAR TRAILER 4S/3M AND ADDITIONAL PRESSURE SENSOR REQUIRED

Copyright WABCO®			WABCO		
Date:	2010-07-26	Signal:	TRAILER - EBS E		
Part:	2010-07-26	Location:	BURMESTER FOR EXTENDABLE OR TELESCOPIC TRAILER		
Part Name:	2010-07-26	Brand:	BURMESTER		
Version:	2010-07-26	Scale:			
Part No.:	449 535 ... 0	Part No. - EBS:	841 802 290 0		
Product No.:	449 535 ... 0	Part No. - ABS:	002 EN 1/1		
Product Denomination:		Revision:	4990		

841 802 292 0

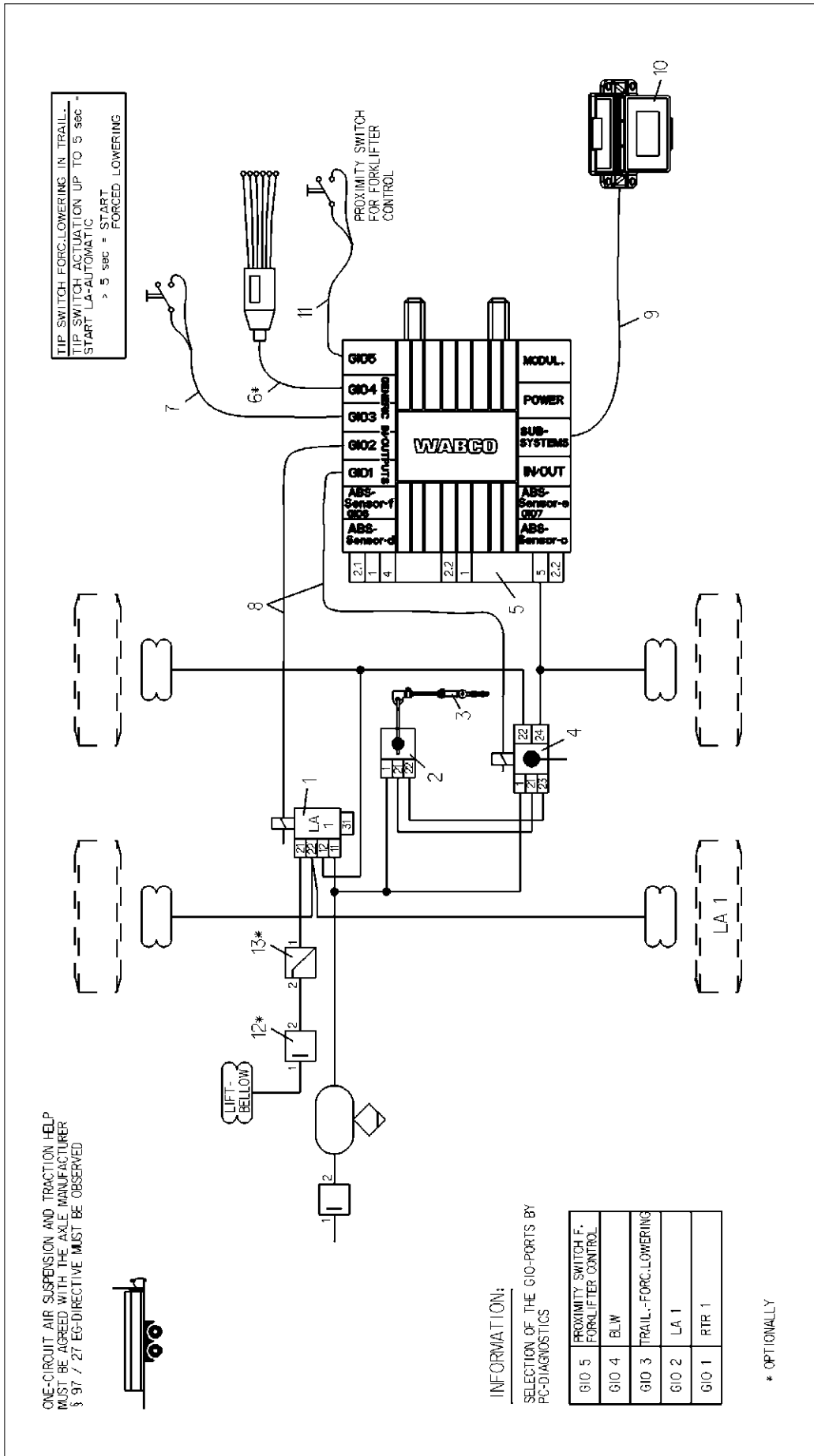

12	1	CHARGING VALVE	* 434 ... 0		
11	1	CABLE PROXIMITY SWITCH	449 ... 0		
10	1	SMARTBOARD	446 192 110 0		
9	1	CABLE-SMARTBOARD	449 911 ... 0		
8	2	CABLE-TASC (RTR) AND LIFTAXLE	449 443 ... 0		
7	1	CABLE-TRAC-ION HELP A: FORCED LOWERING	449 813 ... 0		
6	1	CABLE-BRAKE LIN. WEAR INDIC. (BLW)	* 449 816 ... 0		
5	1	T-EBS E-MODULATOR	480 102 ... 0		
4	1	ROTARY-SLIDE V. W. RTR-FUNCT(ION) ITASC	463 090 00... 0		
3	1	PUSHROD WITH LINKAGE	433 401 003 0		
2	1	LEVELLING VALVE W/O HEIGHT LIMIT.	464 006 010 0		
1	1	LIFTAXLE VALVE	463 084 ... 0	13	1
					Product Identification No. / Denomination
					Product Identification No. / Denomination
					Product Identification No. / Denomination
					Product Identification No. / Denomination
					Product Identification No. / Denomination
					Product Identification No. / Denomination
					Product Identification No. / Denomination
					Product Identification No. / Denomination
					Product Identification No. / Denomination
					Product Identification No. / Denomination

WABCO
TRAILER - EBS E
CONV. AIR SUSPENSION/LA ON AXLE1
FOR CENTRAL AXLE TRAILER
WITH FORKLIFTER CONTROL

Part No.	841 802 292 0
Rev.	EN 1/1
Page	4/9

Part No. 841 802 292 0 Rev. EN 1/1 Page 4/9

841 802 295 0

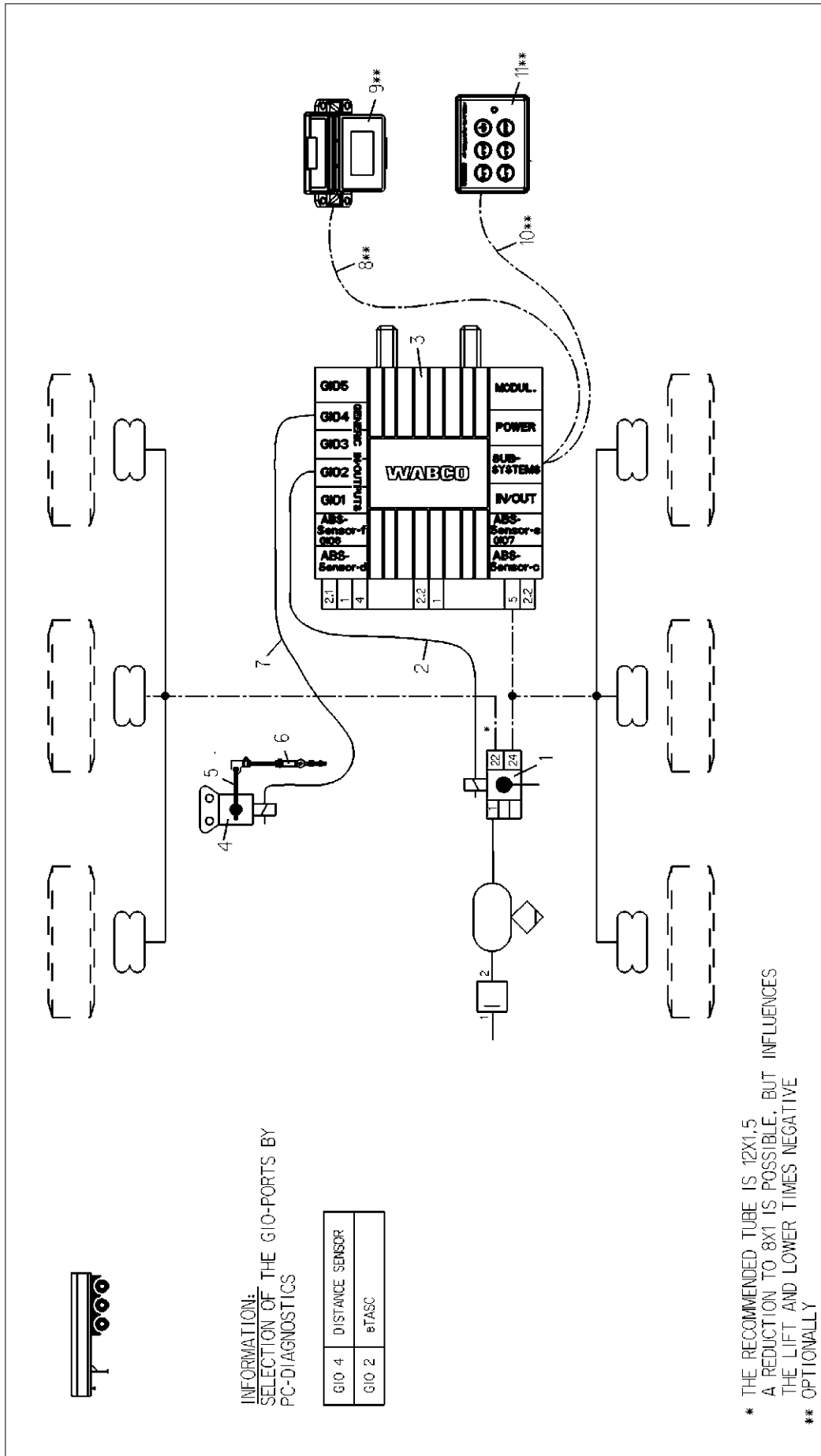

INFORMATION:
SELECTION OF THE GIO-PORTS BY
PC-DIAGNOSTICS

GIO 4	DISTANCE SENSOR
GIO 2	eTASC

* THE RECOMMENDED TUBE IS 12X1,5
A REDUCTION TO 8X1 IS POSSIBLE, BUT INFLUENCES
THE LIFT AND LOWER TIMES NEGATIVE
** OPTIONALLY

Pos.	Qty.	Description	Product Identification No.	Pos.	Qty.	Description	Product Identification No.
11	1	CONTROL BOX	446 156 02. 0	1			
10	1	CABLE CONTROL BOX	449 627 ... 0	2			
9	1	SMARTBOARD	446 192 1. 0	3			
8	1	CABLE SMARTBOARD	449 911 ... 0	4			
7	1	CABLE DISTANCE SENSOR	449 811 ... 0	5			
6	1	PUSH ROD WITH LINKAGE	433 401 003 0	6			
5	1	DISTANCE SENSOR LEVER	441 050 718 2	7			
4	1	DISTANCE SENSOR	441 050 100 0	8			
3	1	EBE-E-MODULATOR	480 102 06. 0	9			
2	1	CABLE eTASC	449 445 ... 0	10			
1	1	eTASC	463 090 5. 0	11			

Copyright WABCO				WABCO			
Part	Year	Signal					
2011-10-04	BURMESTER			TRAILER - EBS E			
2011-10-04	KORDES			FOR SEMITRAILER			
	Lock			2-CIRCUIT			
	Scale			WITHOUT LA			
Part	Year	Scale					
83		20 Scale		Part n. - des.		4990	
Part	Year	20 Scale		ECU ID			
A 3	Pro/E			ECU ID			
Product Identification No.	841 802 295 0	Revision		Part n. - des.			
Product Identification No.		Revision		Part n. - des.			

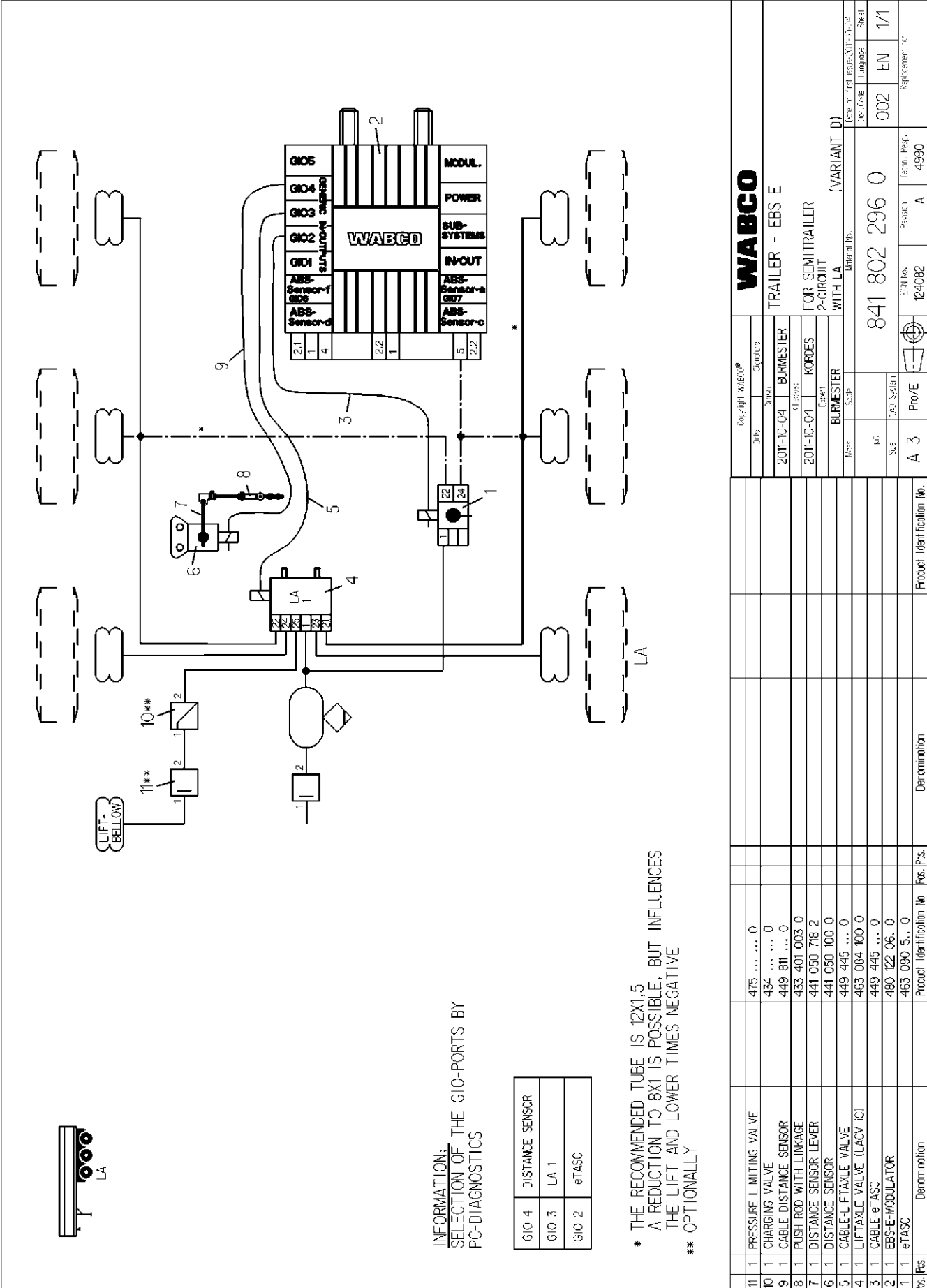

Part No.		Type		Signal	
2011-10-04	BURMESTER	2011-10-04	BURMESTER	2011-10-04	BURMESTER
2011-10-04	KORDES	2011-10-04	KORDES	2011-10-04	KORDES
BURMESTER	BURMESTER	BURMESTER	BURMESTER	BURMESTER	BURMESTER
16	16	16	16	16	16
3	3	3	3	3	3
Pro/E	Pro/E	Pro/E	Pro/E	Pro/E	Pro/E
Product Identification No.		Product Identification No.		Product Identification No.	
4860 122 06 0		4860 122 06 0		4860 122 06 0	
463 050 5.. 0		463 050 5.. 0		463 050 5.. 0	
449 445 ... 0		449 445 ... 0		449 445 ... 0	
441 050 100 0		441 050 100 0		441 050 100 0	
433 401 003 0		433 401 003 0		433 401 003 0	
449 811 ... 0		449 811 ... 0		449 811 ... 0	
434 ... 0		434 ... 0		434 ... 0	
475 ... 0		475 ... 0		475 ... 0	

WABCO
TRAILER - EBS E
FOR SEMITRAILER
2-CIRCUIT
WITH LA (VARIANT D)

Order No. 841 802 296 0
Type Code EN
Language 1/1
Revision No. 002

Order No. 124082
Product A
Factory Part No. 4990

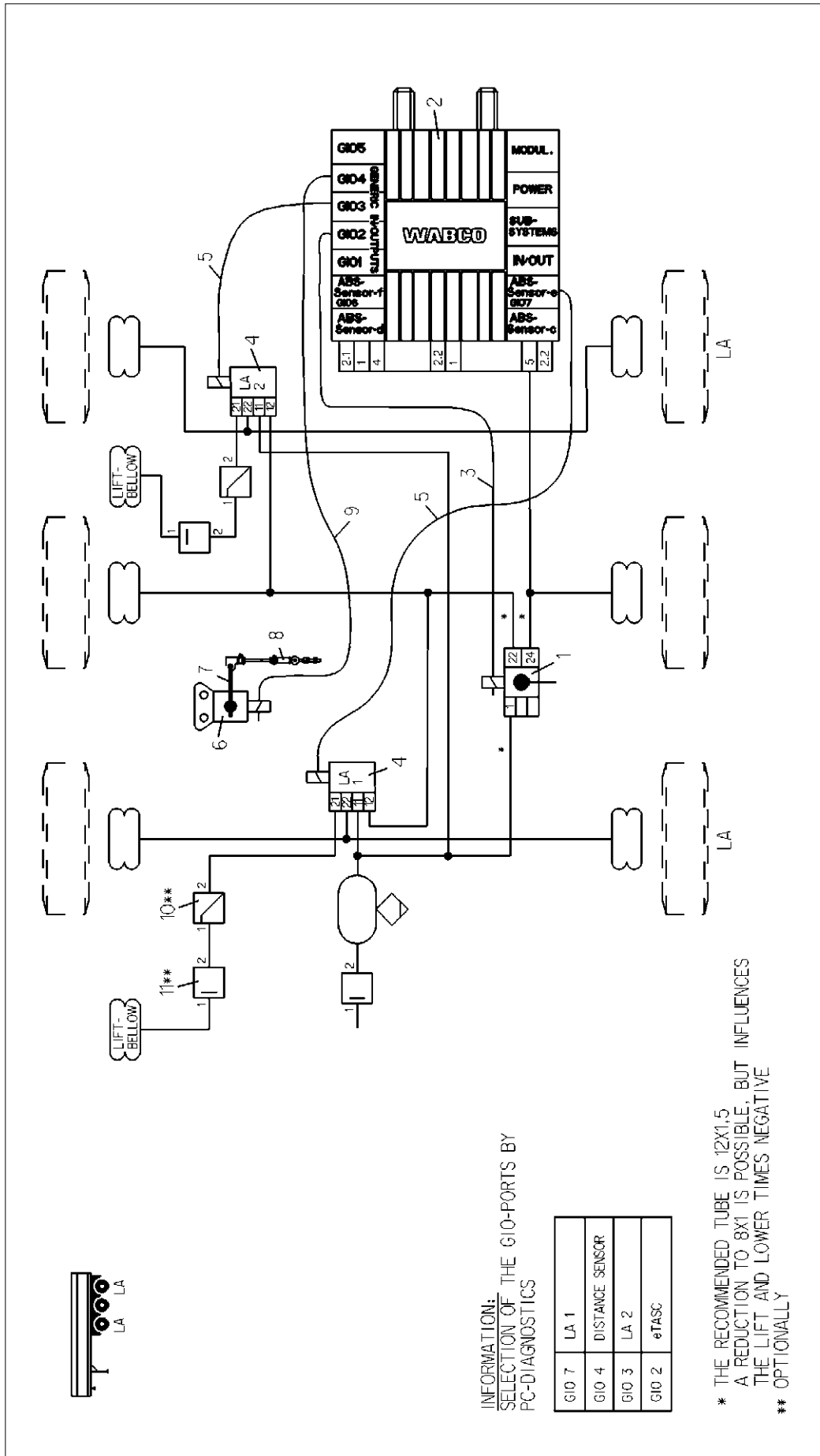

INFORMATION:
SELECTION OF THE GIO-PORTS BY
PC-DIAGNOSTICS

GIO 7	LA 1
GIO 4	DISTANCE SENSOR
GIO 3	LA 2
GIO 2	eTASC

* THE RECOMMENDED TUBE IS 12X1,5
A REDUCTION TO 8X1 IS POSSIBLE, BUT INFLUENCES
THE LIFT AND LOWER TIMES NEGATIVE
** OPTIONALLY

Copyright WABCO®		Date:		Signal: y	
		2011-10-04		BURMESTER	
		2011-10-04		KORDES	
		BURMESTER		SCALE	
		K2		20 Scale	
		A 3		Pro/E	
Product Identification No.		841 802 297 0		Revision	
Denomination		TRAILER - EBS E		Part n. des.	
Product Identification No.		4990		Revision for	
Denomination		FOR SEMITRAILER		Doc. Code	
Product Identification No.		LA 1+3 (VARIANTE N)		Language	
Denomination		2-CIRCUIT		Sheet	
Product Identification No.		002		EN	
Denomination		1/1			

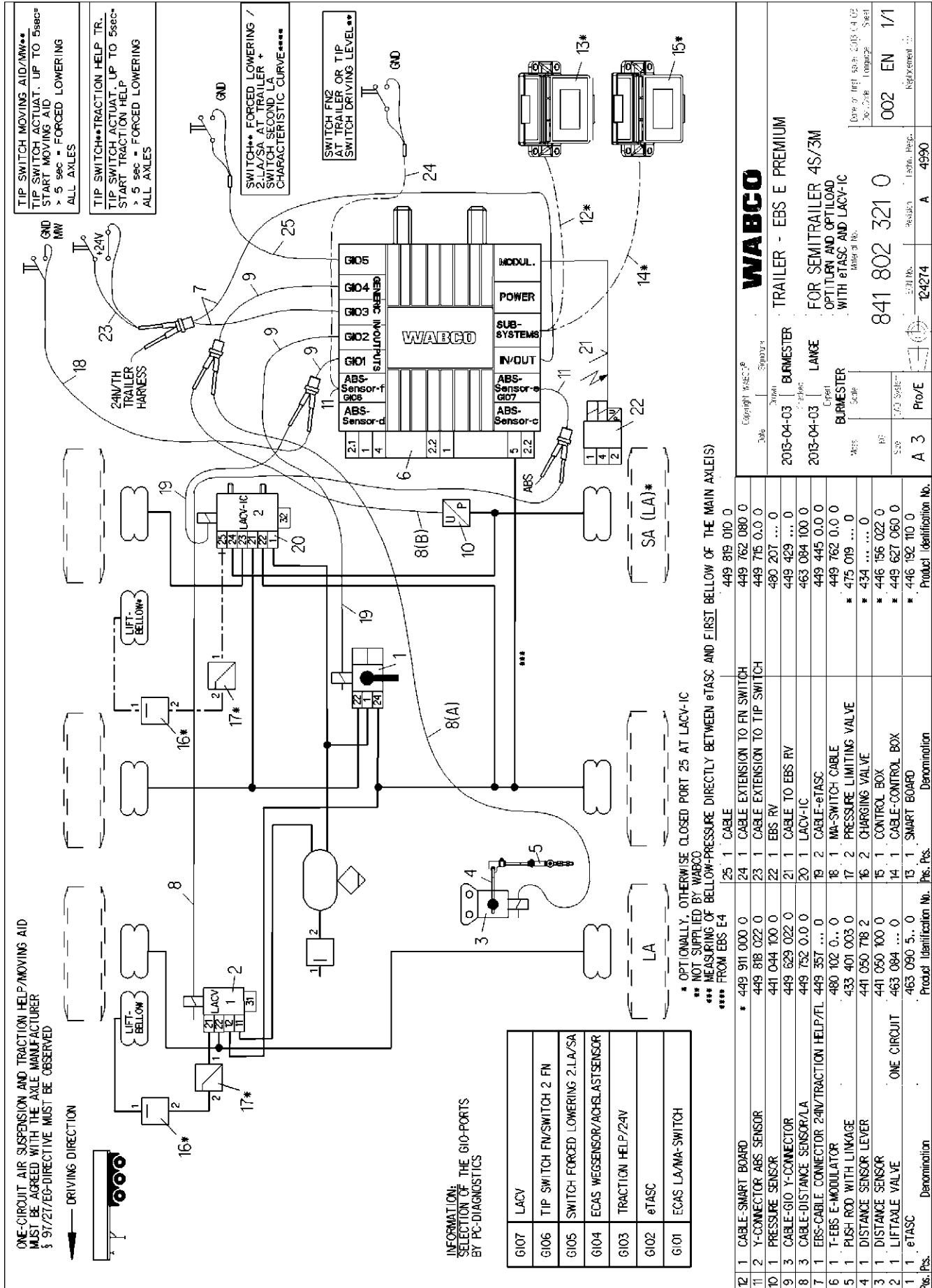

WABCO
 TRAILER - EBS E PREMIUM
 FOR SEMITRAILER 4S/3M
 OPTIFURN AND OPTILOAD
 WITH eTASC AND LACV-IC

Part No. 841 802 321 0
 Revision: 124274 A
 Date: 02/2014

Scale: 1:1
 Drawing No. 841 802 321 0
 Language: EN

Part No. 4990
 Revision: A
 Date: 02/2014

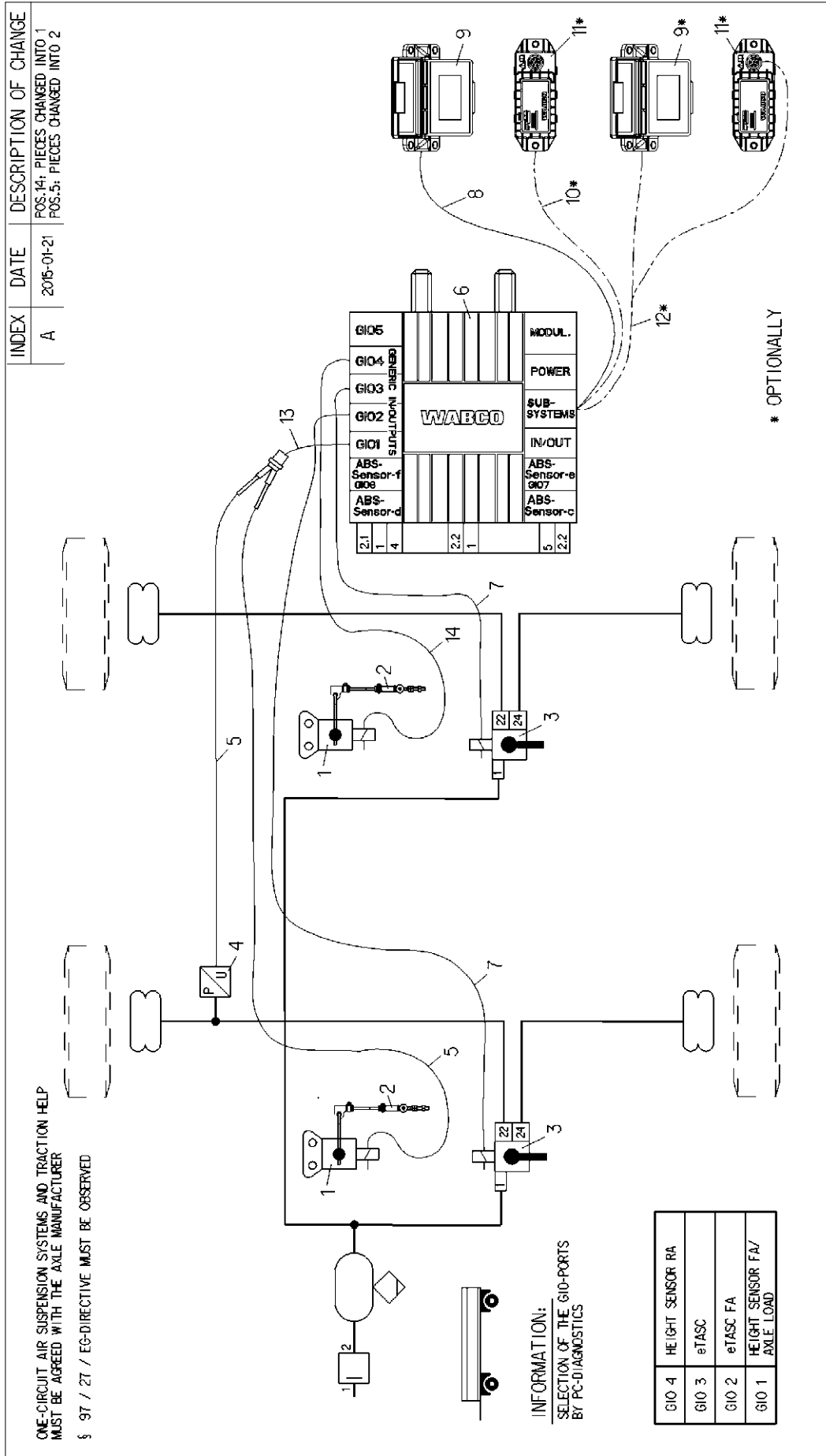

INDEX	DATE	DESCRIPTION OF CHANGE
A	2015-01-21	POS.14: PIECES CHANGED INTO 1 POS.5: PIECES CHANGED INTO 2

Year	Start	End	Subst.
2014-03-10	BURMESTER		
2014-03-10	GOING		

Mass	Scale	Unit	Part No.
BURMESTER			
132			
A 3	CREO		

Doc. Code	Doc. Title	Doc. No.	Doc. Rev.
002	EN	1/1	

Part No.	Part Name	Revision
841 802 322 0	TRAILER - EBS E FOR TRAILER AIR SUSPENSION	A

Product Identification No.	Denomination
449 811 ... 0	CABLE HEIGHT SENSOR
449 629 ... 0	Y-CABLE

ONE-CIRCUIT AIR SUSPENSION SYSTEMS AND TRACTION HELP MUST BE AGREED WITH THE AXLE MANUFACTURER
 § 97 / 27 / EG-DIRECTIVE MUST BE OBSERVED

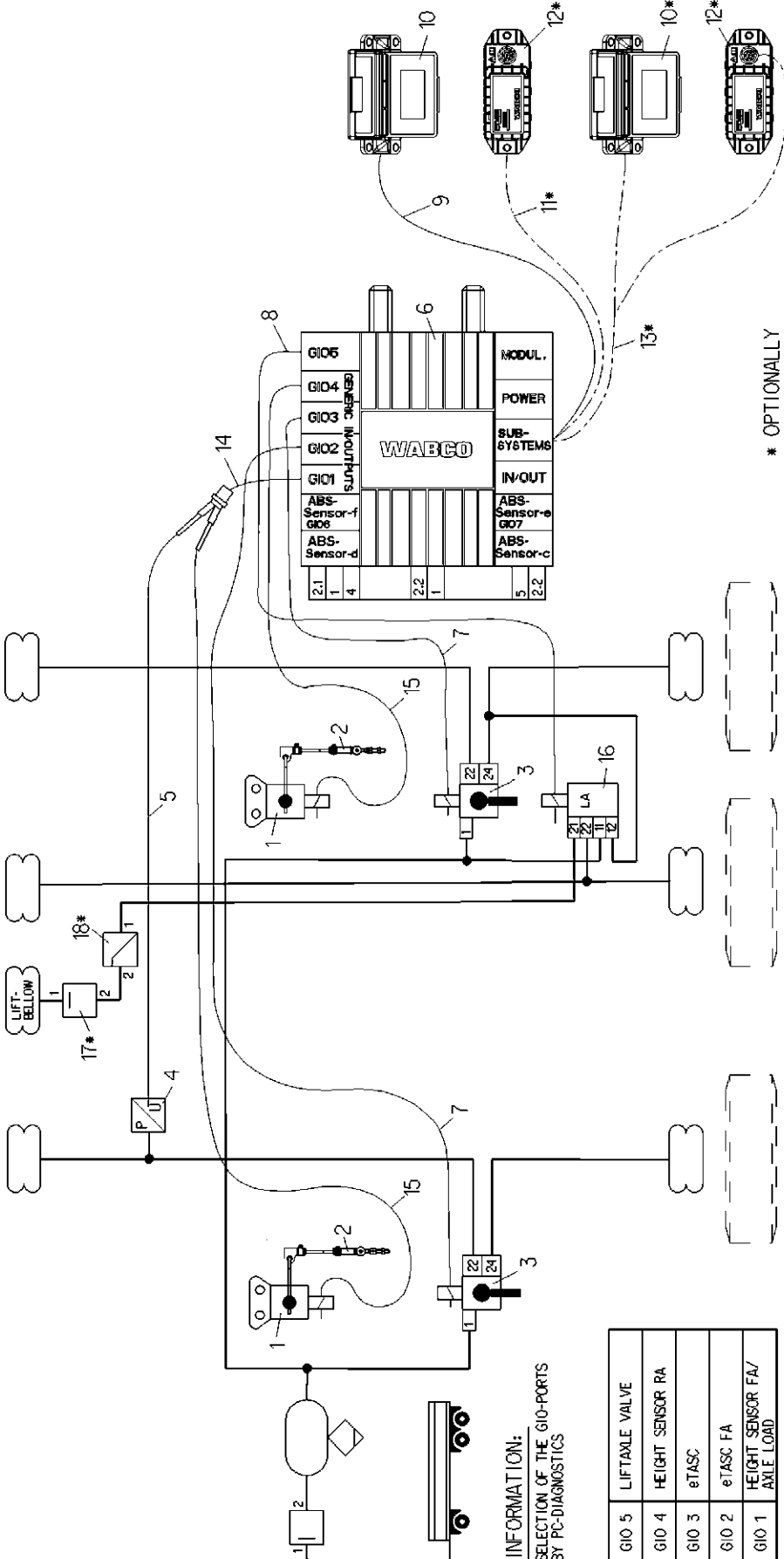

INFORMATION:
 SELECTION OF THE GIO-PORTS
 BY PC-DIAGNOSTICS

GIO 5	LIFTAXLE VALVE
GIO 4	HEIGHT SENSOR RA
GIO 3	eTASC
GIO 2	eTASC FA
GIO 1	HEIGHT SENSOR FA / AXLE LOAD

* OPTIONALLY

		TRAILER - EBS E FOR DRAWBAR TRAILER AIR SUSPENSION	
2014-04-15 Checked		BURMESTER	
2014-04-15 Approved		GONG	
46 Subst. Code		BURMESTER	
A 3 Prod. System		WITH LIFTAXLE AND eTASC Airtec Inc.	
446 220 ... 0 * 449 913 000 0 * 446 192 110 0 * 449 911 000 0 * 449 443 ... 0 * 449 445 000 0 * 480 102 ... 0 * 449 752 000 0 * 441 040 ... 0 * 463 090 5... 0 * 433 401 003 0 * 441 050 100 0		* 434 ... 0 * 475 ... 0 * 463 084 031 0 * 449 811 ... 0 * 449 629 ... 0 * 449 ... 0	
Pos./Pos. Denomination		Pos./Pos. Denomination	
Product Identification No.		Product Identification No.	
841 802 325 0		4990	
002 EN 1/1		4990	

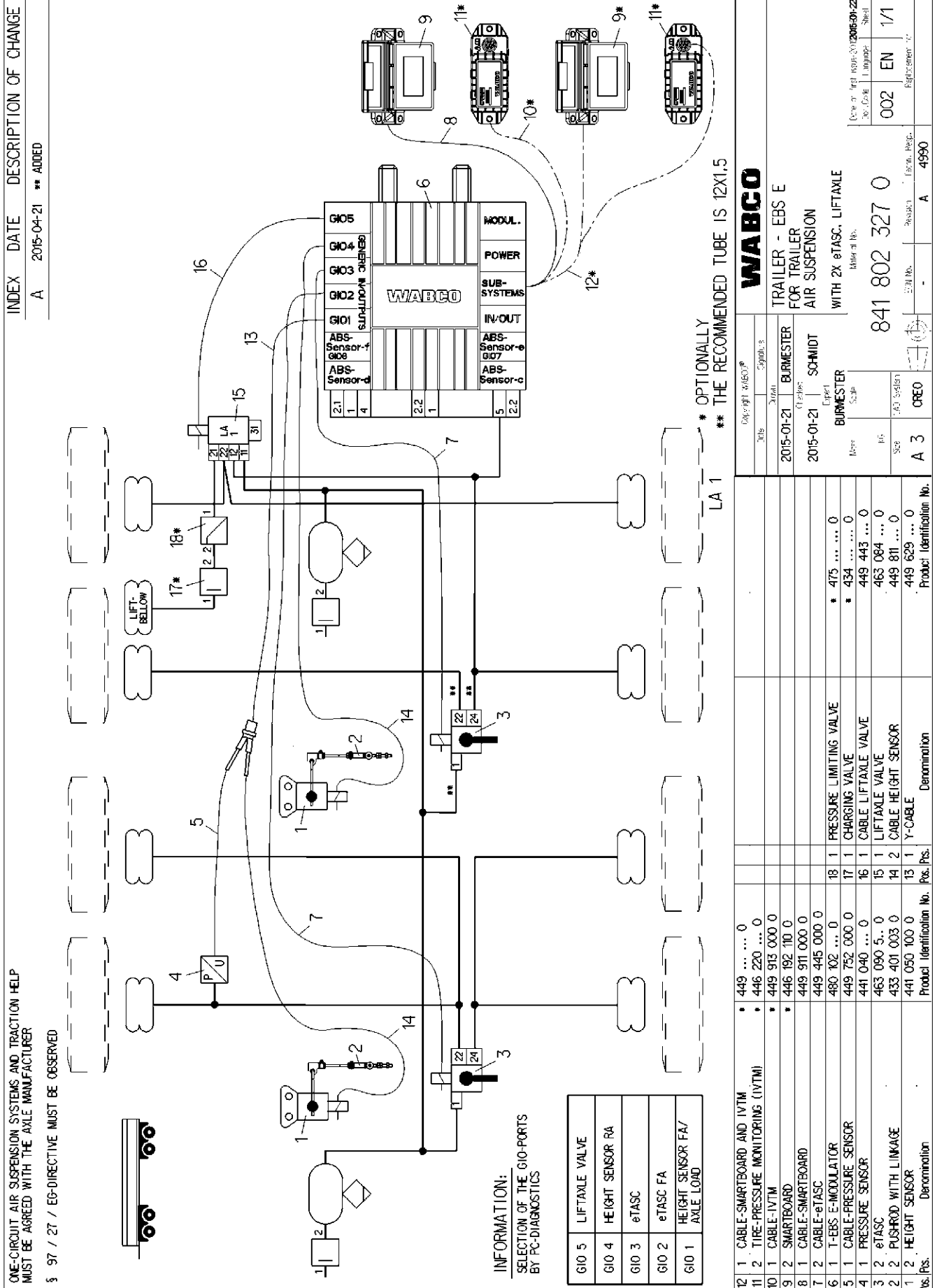

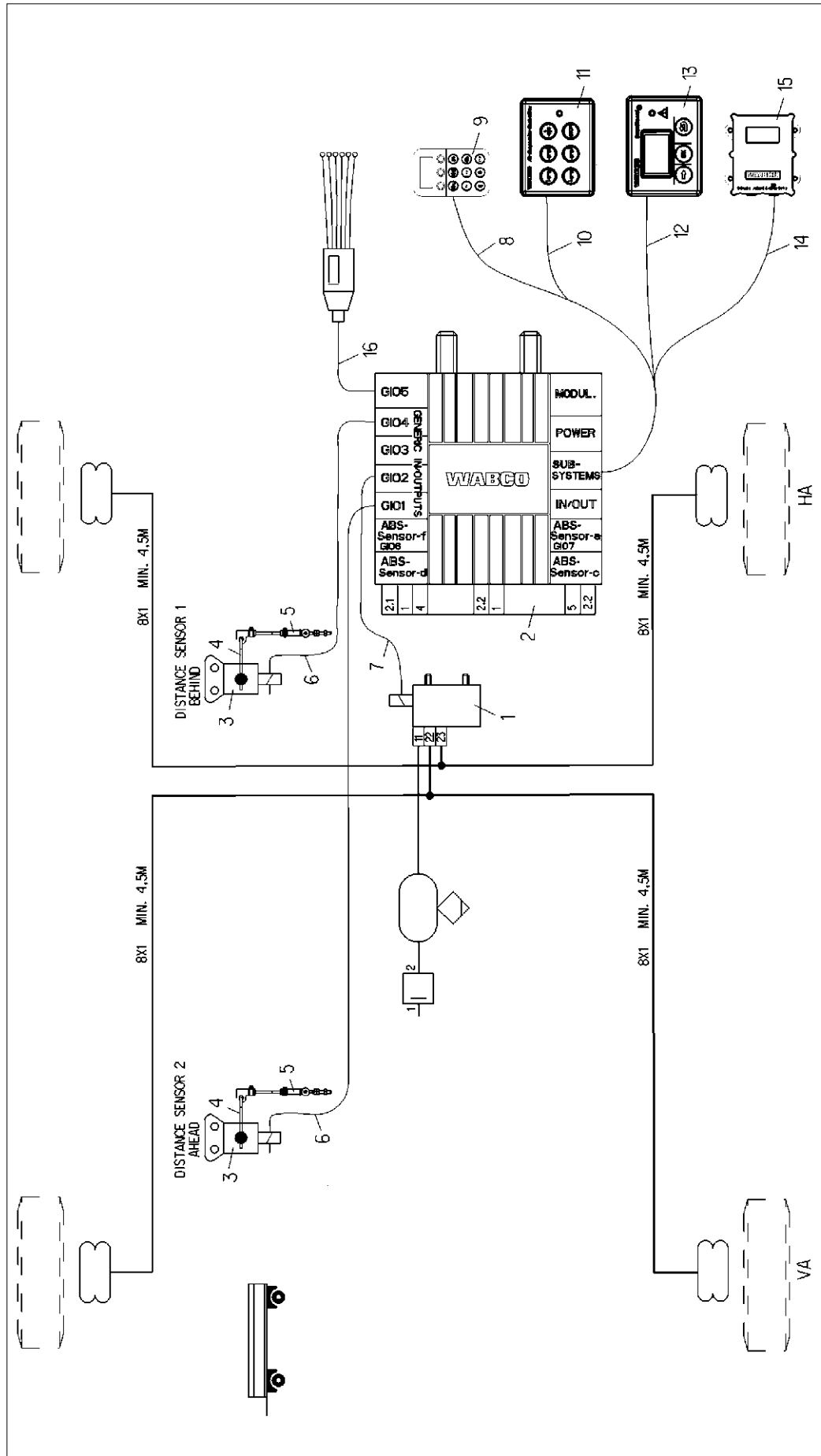

12	1	CABLE SMARTBOARD	449 911 ... 0	24			
11	1	CONTROL BOX	446 156 02. 0	23			
10	1	CABLE CONTROL BOX	449 627 ... 0	22			
9	1	CONTROL UNIT	446 056 117 0	21			
8	1	CABLE CONTROL UNIT	449 628 ... 0	20			
7	1	CABLE ECAS VALVE	449 439 ... 0	19			
6	2	CABLE DISTANCE SENSOR	449 811 ... 0	18			
5	2	PUSH ROD WITH LINKAGE	433 401 003 0	17			
4	2	DISTANCE SENSOR LEVER	441 050 718 2	16	1	CABLE WITH SOCKET	449 816 ... 0
3	2	DISTANCE SENSOR	441 050 100 0	15	1	TELEMATIC	446 290 110 0
2	1	ECAS-MODULATOR	480 102 ... 0	14	1	CABLE TELEOMATIC	449 917 ... 0
1	1	ECAS VALVE	472 860 001 0	13	1	SMARTBOARD	446 192 11. 0
Pos.	Pos.	Denomination	Product Identification No.	Pos. Pos.	Denomination	Product Identification No.	

Copyright WABCO®		Date: 2014-12-02		Signal's: BURMESTER		Date of issue: 2014-12-02	
Date: 2014-12-02		Scale: BURMESTER		Part n. desig.: 841 802 329 0		Revision: 002	
Part n. desig.: BURMESTER		Scale: 1:1		Part n. desig.: 841 802 329 0		Revision: EN 1/1	
Part n. desig.: A 3		Scale: CREO		Part n. desig.: 4990		Revision: 4990	

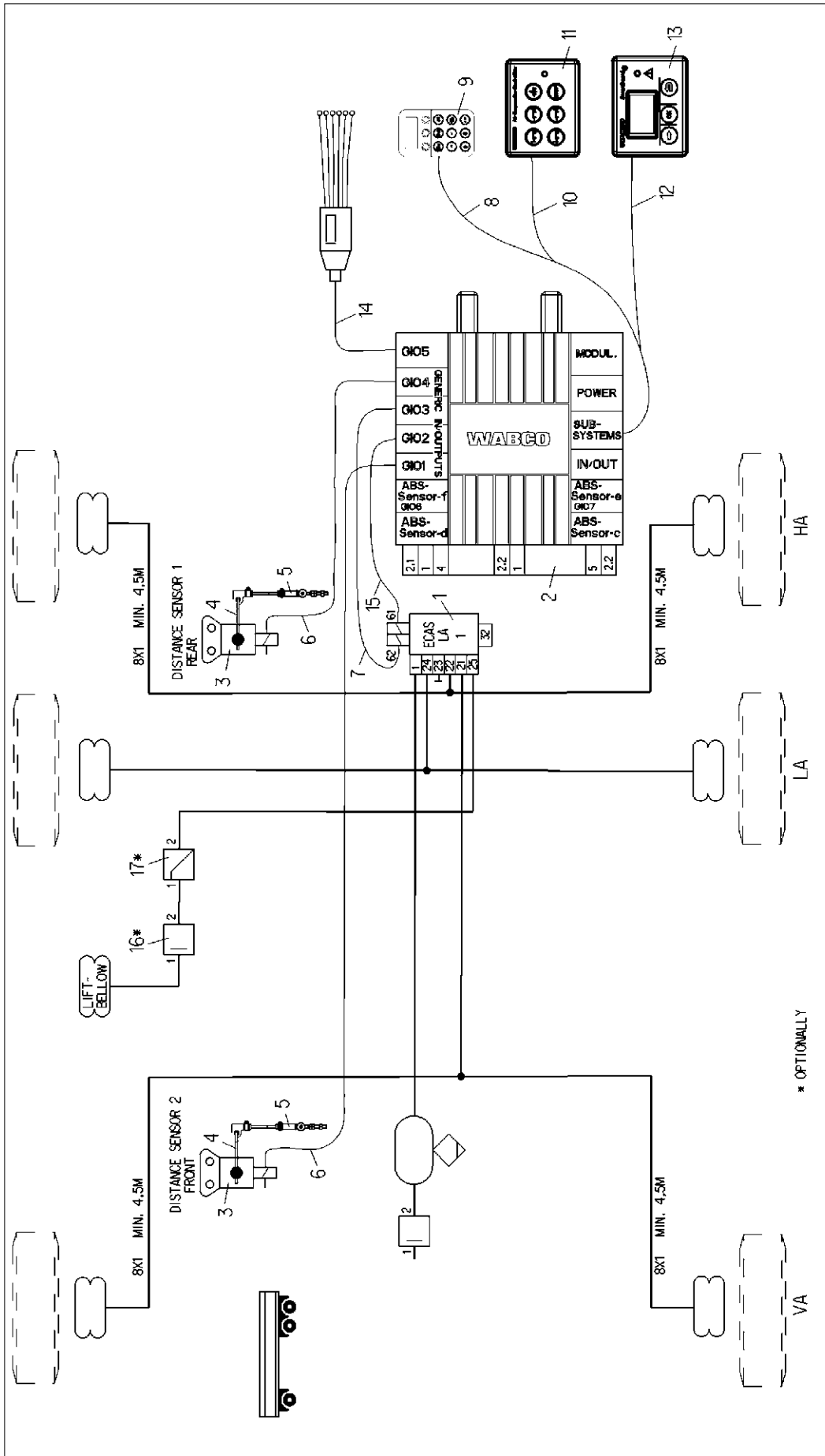

2015-01-26		2015-01-26		2015-01-26		2015-01-26		2015-01-26	
City	From	City	From	City	From	City	From	City	From
	BURMESTER		BURMESTER		BURMESTER		BURMESTER		BURMESTER
	MENTZENDORFF		MENTZENDORFF		MENTZENDORFF		MENTZENDORFF		MENTZENDORFF
	BURMESTER		BURMESTER		BURMESTER		BURMESTER		BURMESTER
	434 ... 0		434 ... 0		434 ... 0		434 ... 0		434 ... 0
	475 ... 0		475 ... 0		475 ... 0		475 ... 0		475 ... 0
	449 439 030 0		449 439 030 0		449 439 030 0		449 439 030 0		449 439 030 0
	449 816 ... 0		449 816 ... 0		449 816 ... 0		449 816 ... 0		449 816 ... 0
	446 192 11 0		446 192 11 0		446 192 11 0		446 192 11 0		446 192 11 0
	Product Identification No.		Product Identification No.		Product Identification No.		Product Identification No.		Product Identification No.
	Denomination		Denomination		Denomination		Denomination		Denomination
	Pos./Pcs.		Pos./Pcs.		Pos./Pcs.		Pos./Pcs.		Pos./Pcs.

Pos./Pcs.	Denomination	Product Identification No.	Pos./Pcs.	Denomination
12 1	CABLE SMARTBOARD	449 911 ... 0	24	
11 1	CONTROL BOX	446 156 02 0	23	
10 1	CABLE CONTROL BOX	449 627 ... 0	22	
9 1	CONTROL UNIT	446 056 11 0	21	
8 1	CABLE CONTROL UNIT	449 628 ... 0	20	
7 1	CABLE ECAS	449 445 ... 0	19	
6 2	CABLE DISTANCE SENSOR	449 811 ... 0	18	
5 2	PUSH ROD WITH LINKAGE	433 401 003 0	17 1	CHARGING VALVE
4 2	DISTANCE SENSOR LEVER	441 050 718 2	16 1	PRESSURE LIMITING VALVE
3 2	DISTANCE SENSOR	441 050 100 0	15 1	CABLE ECAS
2 1	EBS-E-MODULATOR	480 102 0 ... 0	14 1	CABLE WITH SOCKET
1 1	ECAS-BLOCK	472 905 111 0	13 1	SMARTBOARD
	Denomination	Product Identification No.	Pos./Pcs.	Denomination

WABCO		WABCO		WABCO	
City	From	City	From	City	From
	BURMESTER		BURMESTER		BURMESTER
	MENTZENDORFF		MENTZENDORFF		MENTZENDORFF
	BURMESTER		BURMESTER		BURMESTER
	434 ... 0		434 ... 0		434 ... 0
	475 ... 0		475 ... 0		475 ... 0
	449 439 030 0		449 439 030 0		449 439 030 0
	449 816 ... 0		449 816 ... 0		449 816 ... 0
	446 192 11 0		446 192 11 0		446 192 11 0
	Product Identification No.		Product Identification No.		Product Identification No.
	Denomination		Denomination		Denomination
	Pos./Pcs.		Pos./Pcs.		Pos./Pcs.

WABCO		WABCO		WABCO	
City	From	City	From	City	From
	BURMESTER		BURMESTER		BURMESTER
	MENTZENDORFF		MENTZENDORFF		MENTZENDORFF
	BURMESTER		BURMESTER		BURMESTER
	434 ... 0		434 ... 0		434 ... 0
	475 ... 0		475 ... 0		475 ... 0
	449 439 030 0		449 439 030 0		449 439 030 0
	449 816 ... 0		449 816 ... 0		449 816 ... 0
	446 192 11 0		446 192 11 0		446 192 11 0
	Product Identification No.		Product Identification No.		Product Identification No.
	Denomination		Denomination		Denomination
	Pos./Pcs.		Pos./Pcs.		Pos./Pcs.

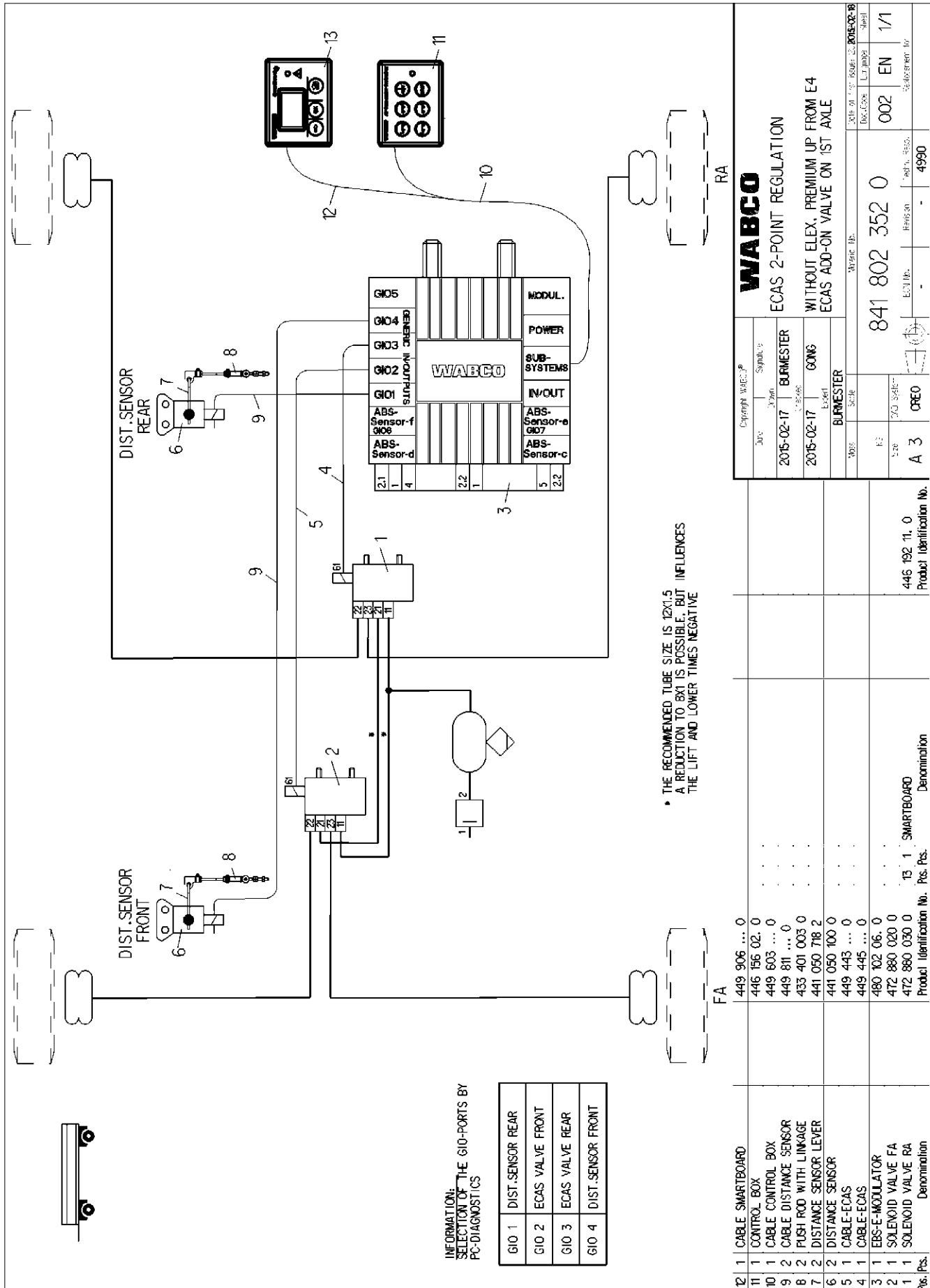

Copyright WABCO®		Date:	2015-02-17	Issue:	2015-02-17
Signal's:		Doc. Code:	BURMESTER	Doc. Code:	BURMESTER
Date:		2015-02-17	Scale:	1:1	Sheet:
Title:		2015-02-17	Scale:	1:1	Sheet:
Part No.:		841 802 352 0	Part No.:	4990	Part No.:
Part No.:		841 802 352 0	Part No.:	4990	Part No.:
Part No.:		841 802 352 0	Part No.:	4990	Part No.:

WABCO
ECAS 2-POINT REGULATION
WITHOUT ELEX, PREMIUM UP FROM E4
ECAS ADD-ON VALVE ON 1ST AXLE

12	1	CABLE SMARTBOARD	449 906 ... 0	Product Identification No.	
11	1	CONTROL BOX	446 156 02. 0	Product Identification No.	
10	1	CABLE CONTROL BOX	449 603 ... 0	Product Identification No.	
9	2	CABLE DISTANCE SENSOR	449 811 ... 0	Product Identification No.	
8	2	PUSH ROD WITH LINKAGE	433 401 003 0	Product Identification No.	
7	2	DISTANCE SENSOR LEVER	441 050 718 2	Product Identification No.	
6	2	DISTANCE SENSOR	441 050 100 0	Product Identification No.	
5	1	CABLE-ECAS	449 443 ... 0	Product Identification No.	
4	1	CABLE-ECAS	449 445 ... 0	Product Identification No.	
3	1	ECAS-E-MODULATOR	480 102 06. 0	Product Identification No.	
2	1	SOLENOID VALVE FA	472 880 020 0	Product Identification No.	
1	1	SOLENOID VALVE RA	472 880 030 0	Product Identification No.	
Pos. Pcs.		Denomination			
		Denomination			

841 802 353 0

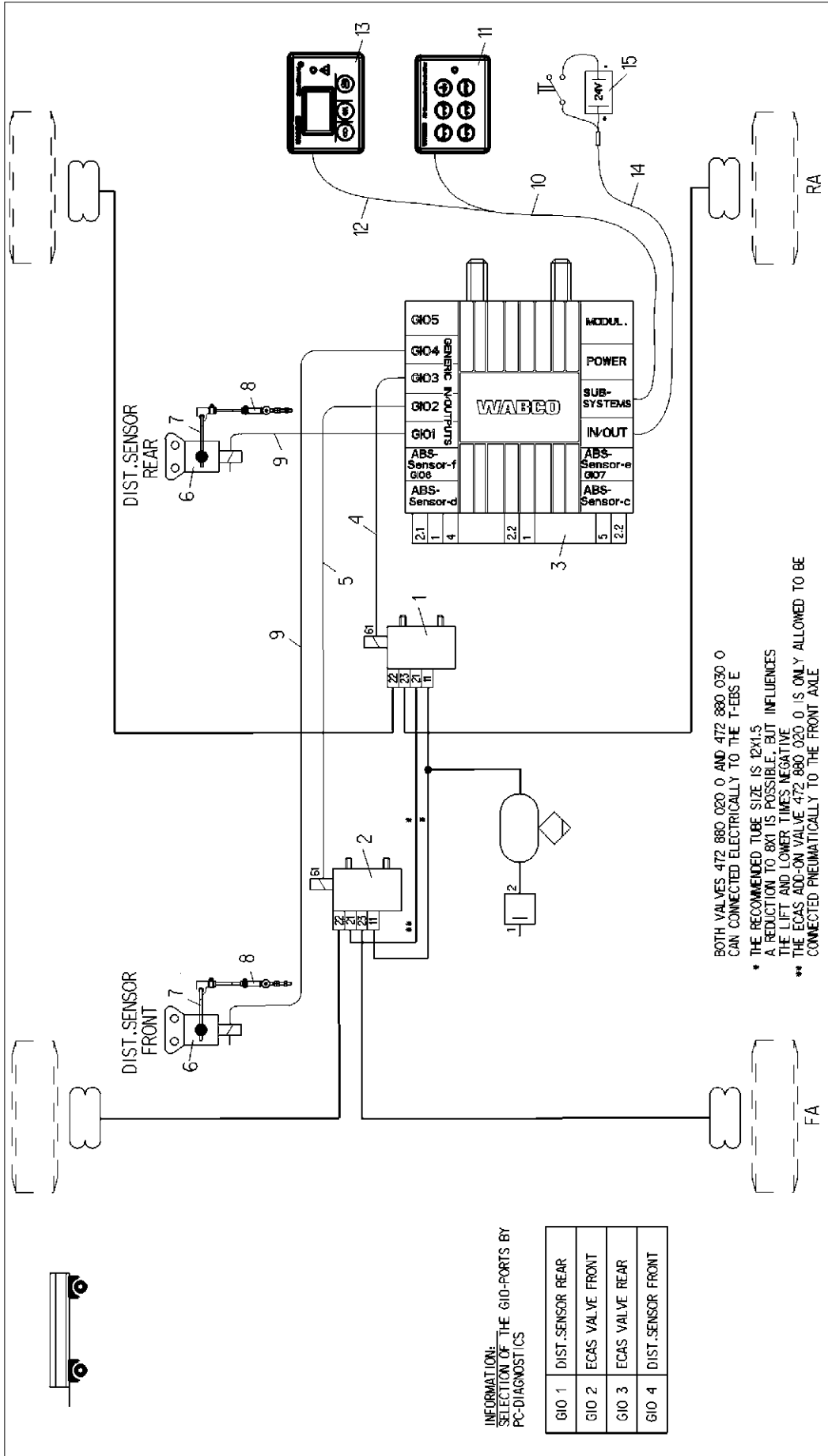

INFORMATION:
SELECTION OF THE GIO-PORTS BY
PC-DIAGNOSTICS

GIO 1	DIST. SENSOR REAR
GIO 2	ECAS VALVE FRONT
GIO 3	ECAS VALVE REAR
GIO 4	DIST. SENSOR FRONT

BOTH VALVES 472 880 020 0 AND 472 880 030 0 CAN CONNECTED ELECTRICALLY TO THE T-ABS E

- * THE RECOMMENDED TUBE SIZE IS 12X1.5 A REDUCTION TO 8X1 IS POSSIBLE, BUT INFLUENCES THE LIFT AND LOWER TIMES. NEGATIVE
- ** CONNECTED PNEUMATICALLY TO THE FRONT AXLE

12 1 CABLE SMARTBOARD		449 906 ... 0	<p>WABCO ECAS 2-POINT REGULATION WITHOUT ELEX, PREMIUM UP FROM E4 ECAS ADD-ON VALVE ON 1ST AXLE</p> <p>2015-02-17 2015-02-17 GONG BURMESTER</p> <p>WABCO Part No. 841 802 353 0 Issue Date: 2015-02-17 Doc. Code: EN 1/1 Regulation for: 4990</p>
11 1 CONTROL BOX		446 156 02. 0	
10 1 CABLE CONTROL BOX		449 603 ... 0	
9 2 CABLE DISTANCE SENSOR		449 811 ... 0	
8 2 PUSH ROD WITH LINKAGE		433 401 003 0	
7 2 DISTANCE SENSOR LEVER		441 050 718 2	
6 2 DISTANCE SENSOR		441 050 100 0	
5 1 CABLE-ECAS		449 443 ... 0	
4 1 CABLE-ECAS		449 445 ... 0	
3 1 EBS-E-MODULATOR		480 102 06. 0	
2 1 SOLENOID VALVE FA		472 880 020 0	
1 1 SOLENOID VALVE RA		472 880 030 0	
Pos.	Pos.	Product Identification No.	Denomination
		449 349 ... 0	
		446 192 11. 0	
A 3		CREO	
E3			
12			
12		Product Identification No.	

2 Braking diagrams

2.1 Semitrailer

AXLE(S)	ABS SYSTEM	NUMBER	TRISTOP™	OVERLOAD PROTECTION VALVE	PEM	MECHANICAL SUSPENSION	ADDITIONAL TRAILER	PREV	COMMENT	PAGE
1	2S/2M	841 701 180 0	x	x				x		72
1	2S/2M	841 701 181 0	x				x	x	Dolly / hydraulic suspension	73
1	2S/2M	841 701 182 0	x		x			x		74
1	2S/2M	841 701 183 0	x	x				x	12 V	75
1	2S/2M	841 701 201 0	x					x		76
1	2S/2M	841 701 202 0	x							77
1	2S/2M	841 701 203 0								78
2	4S/2M 2S/2M	841 701 190 0	x	x				x		79
2	4S/3M	841 701 191 0	x	x				x		80
2	2S/2M	841 701 192 0	x	x						81
2	4S/2M 2S/2M	841 701 193 0	x		x			x		82
2	4S/3M	841 701 195 0	x		x			x	Only one axle Tristop™	83
2	4S/3M	841 701 196 0	x		x			x		84
2	4S/2M 2S/2M	841 701 197 0	x		x	x		x		85
2	4S/2M 2S/2M	841 701 198 0	x			x		x	one Tristop™ separate	86
2	4S/3M	841 701 199 0	x	x			x	x	CAN router	87
2	4S/2M 2S/2M	841 701 270 0	x	x			x	x	CAN router	88
2	2S/2M	841 701 271 0	x		x			x	CAN router	89
2	4S/3M	841 701 272 0	x					x		90
2	4S/2M 2S/2M	841 701 273 0	x					x		91
2	4S/2M 2S/2M	841 701 276 0								92
2	2S/2M	841 701 277 0	x	x				x	Select Low	93
2	2S/2M	841 701 278 0	x	x		x		x	Select Low / optional RSS	94
3	4S/3M	841 701 050 0	x					x		95
3	4S/3M	841 701 055 0	x						CAN repeater	96
3	4S/3M	841 701 057 0	x	x				x	CAN repeater and Select Low	97
3	4S/3M	841 701 058 0	x	x				x	CAN repeater	98
3	4S/2M 2S/2M	841 701 100 0	x							99
3	4S/2M 2S/2M	841 701 101 0	x					x		100
3	2S/2M	841 701 102 0	x					x	Select Low	101
3	4S/2M+1M	841 701 103 0	x					x		102
3	4S/2M 2S/2M	841 701 104 0	x					x	Trailer Central Electronic	103
3	4S/2M+1M	841 701 105 0	x			x		x		104
3	4S/2M 2S/2M	841 701 106 0	x	x				x		105

Braking diagrams

Semitrailer

AXLE(S)	ABS SYSTEM	NUMBER	TRISTOP™	OVERLOAD PROTECTION VALVE	PEM	MECHANICAL SUSPENSION	ADDITIONAL TRAILER	PREV	COMMENT	PAGE
3	2S/2M	841 701 107 0	x	x				x	Select Low	106
3	2S/2M	841 701 108 0	x		x			x	Select Low (relay valve)	107
3	2S/2M	841 701 109 0	x					x	Select Low (relay valve)	108
3	4S/2M 2S/2M	841 701 110 0	x		x			x	Tristop axles 1 + 2	109
3	4S/3M	841 701 111 0	x		x			x		110
3	2S/2M	841 701 112 0	x	x				x	Select Low (relay valve)	111
3	4S/3M	841 701 113 0	x	x				x		112
3	4S/3M	841 701 114 0	x	x						113
3	4S/2M	841 701 115 0	x		x			x	Internal loader	114
3	4S/2M 2S/2M	841 701 116 0	x	x			x	x		115
3	2S/2M	841 701 117 0	x		x			x	Select Low	116
3	4S/2M+1M	841 701 118 0	x		x			x		117
3	4S/3M	841 701 119 0	x		x			x	EBS relay on axle 1	118
3	4S/2M+1M	841 701 221 0	x		x			x		119
3	4S/2M 2S/2M	841 701 222 0								120
3	4S/2M+1M	841 701 223 0	x	x				x		121
3	4S/3M	841 701 224 0								122
3	4S/2M 2S/2M	841 701 227 0	x		x			x	Immobilizer	123
3	4S/2M 2S/2M	841 701 228 0	x		x		x	x	CAN router	124
3	4S/2M 2S/2M	841 701 229 0	x	x			x	x	CAN router	125
3	4S/2M+1	841 701 230 0	x		x		x	x	CAN router	126
3	4S/2M 2S/2M	841 701 231 0	x		x			x	3 axles Tristop™	127
3	4S/3M	841 701 232 0	x		x			x		128
3	4S/3M	841 701 234 0	x		x		x	x	CAN router	129
3	4S/3M	841 701 235 0	x	x			x	x	CAN router	130
3	2S/2M	841 701 236 0	x		x			x	Select Low + optional relay	131
3	4S/2M 2S/2M	841 701 237 0	x					x		132
3	4S/3M	841 701 238 0	x					x		133
3	4S/2M 2S/2M	841 701 239 0	x		x			x		134
3	4S/2M 2S/2M	841 701 260 0	x	x				x	Multi-voltage	135
3	4S/2M 2S/2M	841 701 261 0	x					x		136
3	4S/2M	841 701 263 0	x	x				x	CAN repeater / 6x Tristop™	137
3	4S/2M 2S/2M	841 701 264 0	x		x			x	LACV / electronic parking brake	138
3	4S/3M	841 701 265 0	x		x			x	3 axles Tristop™	139
4	4S/3M	841 701 050 0	x					x		140
4	4S/3M	841 701 051 0	x	x					Select Low 1st axle	141

Braking diagrams

Semitrailer

AXLE(S)	ABS SYSTEM	NUMBER	TRISTOP™	OVERLOAD PROTECTION VALVE	PEM	MECHANICAL SUSPENSION	ADDITIONAL TRAILER	PREV	COMMENT	PAGE
4	4S/3M	841 701 052 0	x		x			x	Select Low 1st axle (relay valve)	142
4	4S/3M	841 701 053 0	x		x			x	CAN repeater extendable	143
4	4S/3M	841 701 054 0	x		x			x	CAN repeater extendable	144
4	4S/3M	841 701 055 0	x						CAN repeater extendable	145
4	4S/3M	841 701 056 0	x		x			x	Hydraulic suspension	146
4	4S/3M	841 701 059 0	x	x				x	Auxiliary relay	147
4	4S/3M	841 701 240 0	x	x				x	CAN repeater extendable	148
4	4S/3M	841 701 241 0 (only in German available)	x		x			x		149
4	4S/3M	841 701 242 0	x		x			x	3 axles Tristop™	150
4	4S/3M	841 701 244 0	x		x			x	3 axles Tristop™/ optional PR switch	151
4	4S/3M	841 701 245 0	x	x				x	Auxiliary relay at front	152
4	4S/3M	841 701 246 0	x	x				x	Select Low 1st axle / relay at front	153
4	4S/3M	841 701 247 0	x	x				x	CAN repeater / auxiliary relay and air reservoir	154
4	4S/3M	841 701 248 0	x	x				x	CAN repeater / auxiliary relay and air reservoir	155
6	2S/2M + 2S/2M	841 701 300 0	x		x				CAN router 2x ECU	156
7	4S/3M + 2S/2M	841 701 171 0 (only in German available)	x	x				x	CAN router 2x ECU	157
7	4S/3M	841 701 210 0	x					x	Hydraulic suspension	158
7	4S/3M + 2S/2M	841 701 211 0	x		x				CAN router 2x ECU	159
8	2S/2M + 4S/3M	841 701 301 0	x		x				CAN router 2x ECU	160
9	4S/3M + 4S/3M	841 701 302 0	x		x				CAN router 2x ECU	161

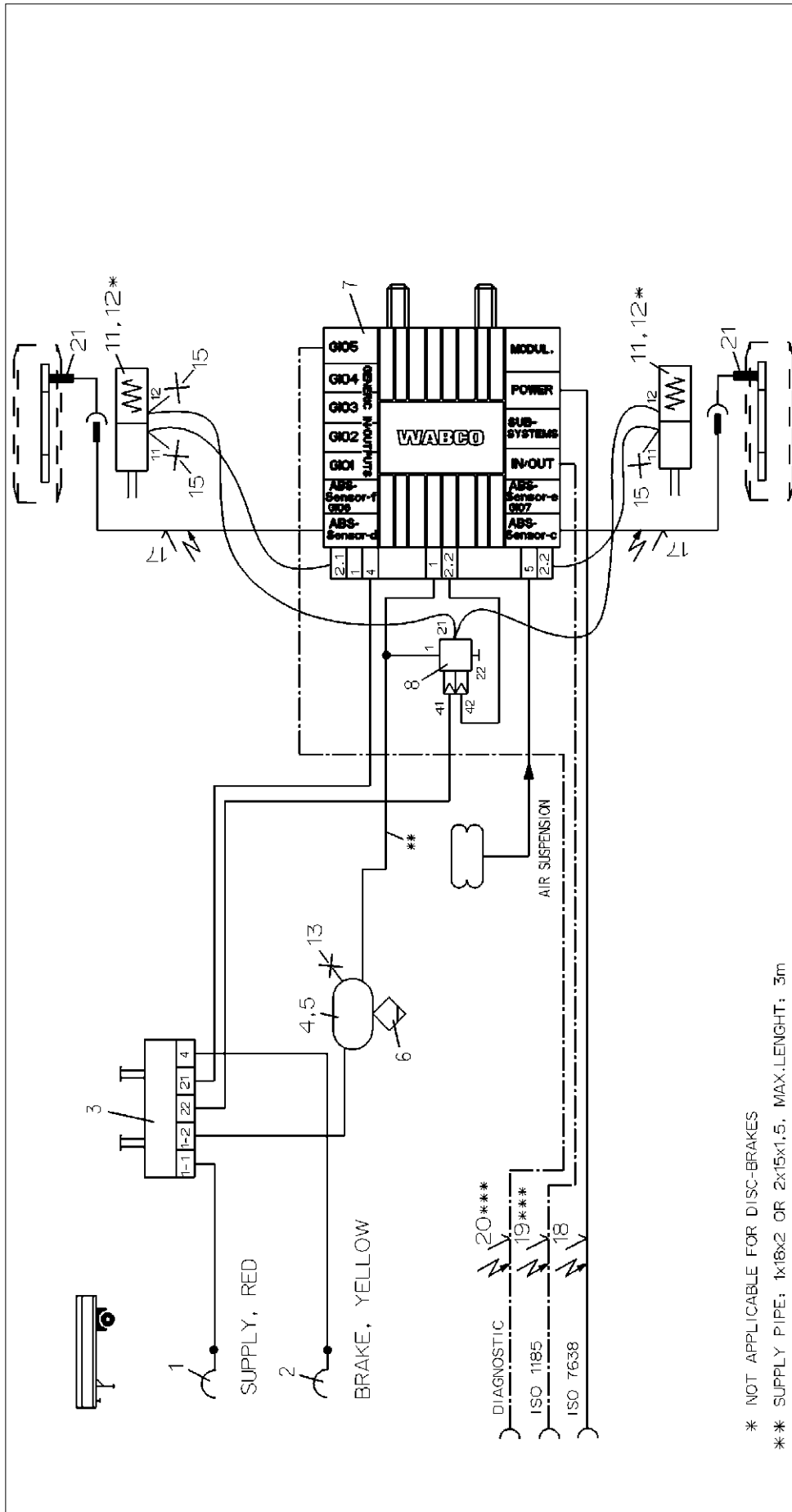

* NOT APPLICABLE FOR DISC-BRAKES
 ** SUPPLY PIPE: 1x18x2 OR 2x15x1.5, MAX. LENGTH: 3m
 PIPING WITHOUT THREAD PIPE ANGLE
 *** OPTIONAL

Pos./Pcs.	Denomination	Product Identification No.	Pos./Pcs.	Denomination	Product Identification No.	Coppertech Wabco, s.p.a.		
						Year	Subst.	Signo. 2
13	TEST CONNECTION	463 703 115 0	25					
12	2 KIT	423 903 532 2	24					
11	TRISTOP BRAKE ACTUATOR	925 0	23					
10			22					
9			21					
8	1 OVERLOAD-PROTECTION-RV	973 011 201 0	21	2	ABS-SENSOR	441 032 8... 0		
7	1 TRAILER-MODULATOR	480 102 ... 0	20	1	DIAGNOSTIC CABLE	449 611 ... 0		
6	1 DRAIN VALVE	934 300 001 0	19	1	24M-CABLE	449 349 ... 0		
5	2 HOSE CLAMP	451 999 ... 2	18	1	SUPPLY (POWER) CABLE	449 173 ... 0		
4	1 LUFTHAEHLER	950 0	17	2	EXTENSION CABLE FOR SENSOR	449 723 ... 0		
3	1 PARK-RELEASE-EMERGENCY VALVE (PREV)	971 002 9... 0	16					
2	1 COUPLING HEAD W.INT. LINE FILTER	952 201 ... 0	15	3	TEST CONNECTION	463 703 036 0		
1	1 COUPLING HEAD W.INT. LINE FILTER	952 201 ... 0	14					

WABCO		Version No.	841 701 180 0	Techn. dep.	4990
TRAILER - EBS E		Year		Drawn by	
FOR 1-AXLE-SEMI TRAILER		Subst.		Checked by	
2S/2M		Signo. 2		Approved by	
BURMESTER		Year		Drawn by	
Date of first issue: 2006-10-06		Subst.		Checked by	
Date of this issue: 2006-10-06		Signo. 2		Approved by	
Version No.		Year		Drawn by	
841 701 180 0		Subst.		Checked by	
Techn. dep.		Signo. 2		Approved by	
4990		Year		Drawn by	

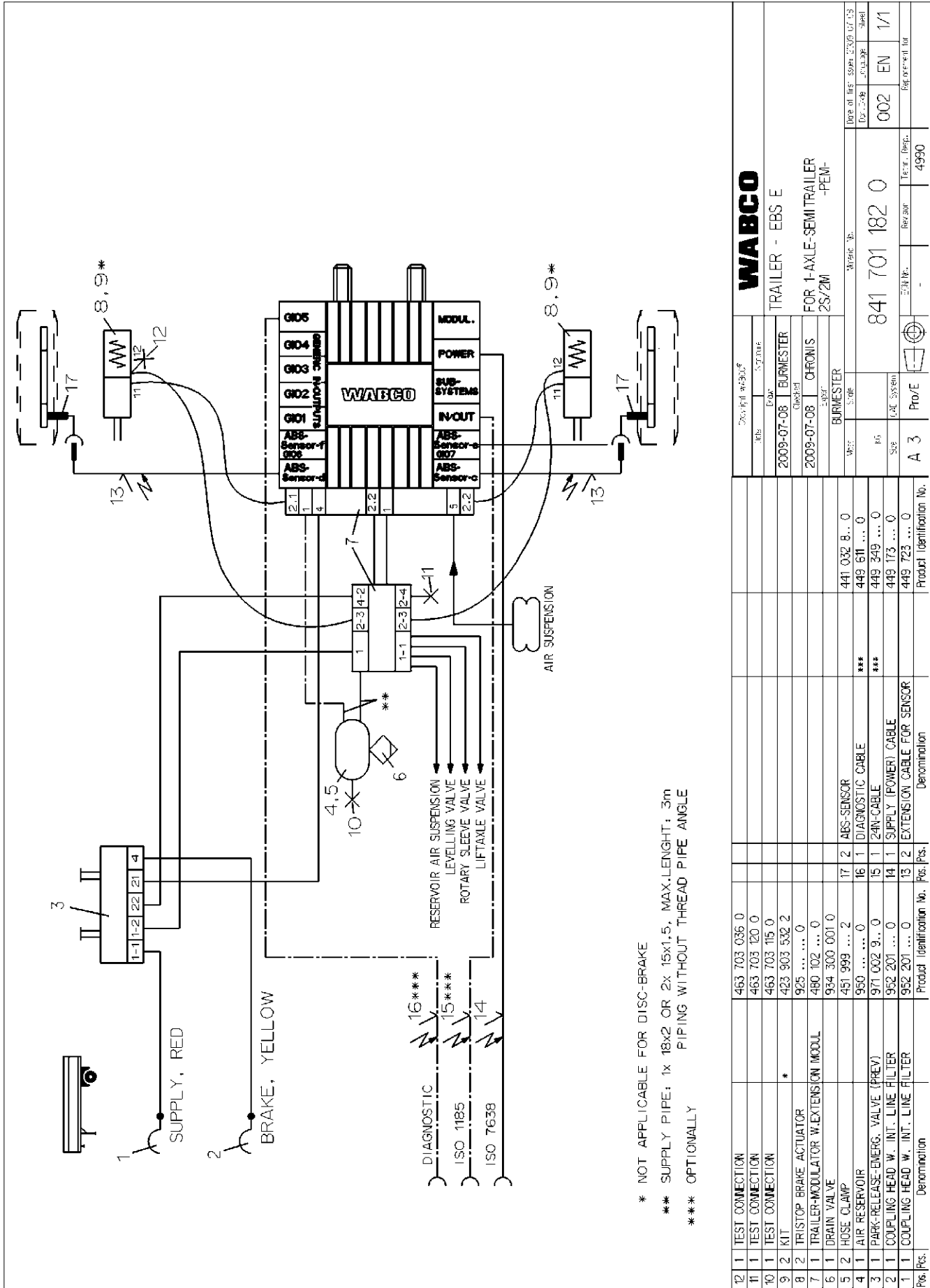

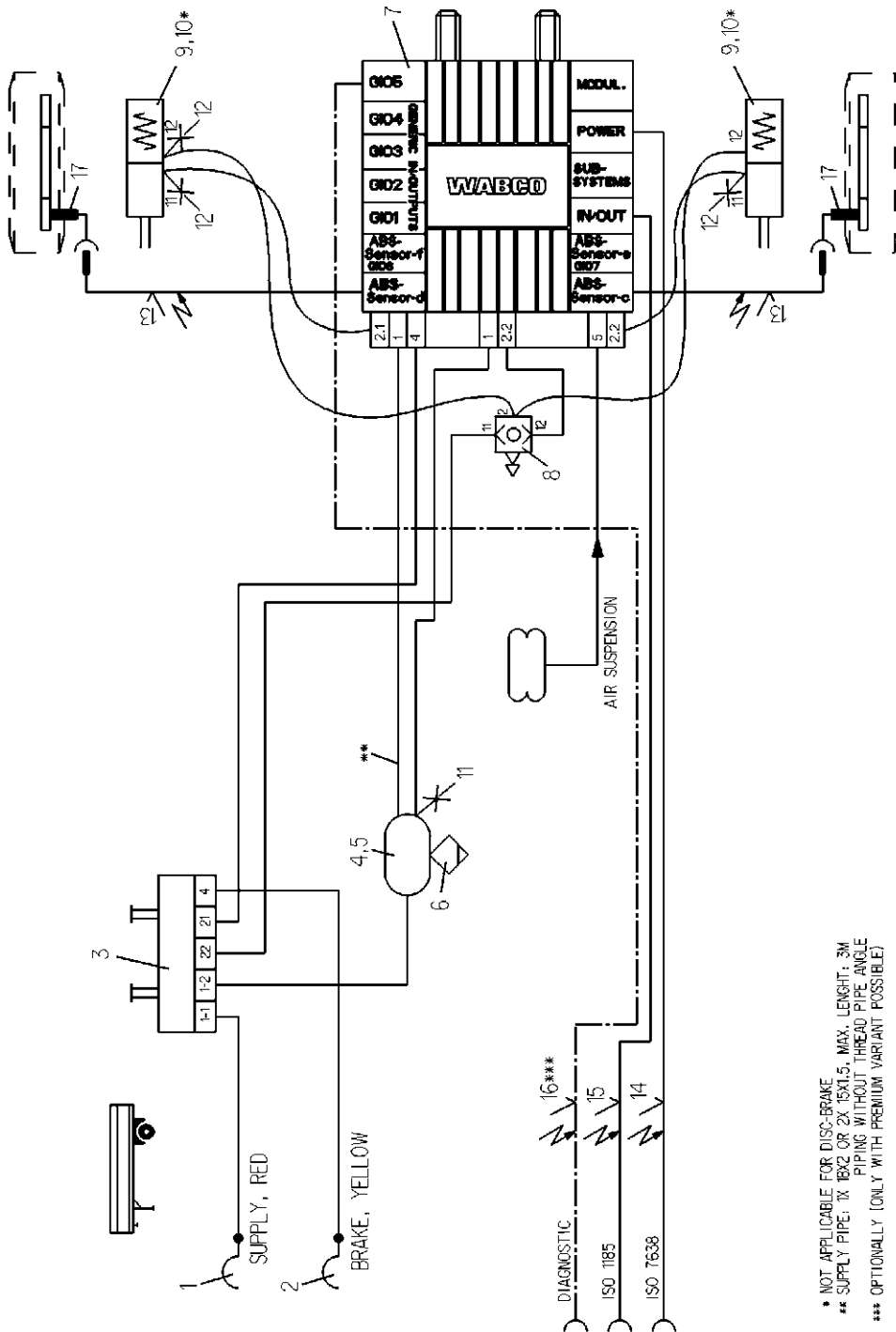

* NOT APPLICABLE FOR DISC-BRAKE
 ** SUPPLY PIPE: 1X 1/2X2 OR 2X 1/2X1.5. MAX. LENGTH: 3M
 PIPING WITHOUT THREAD PIPE ANGLE
 *** OPTIONALLY (ONLY WITH PREMIUM VARIANT POSSIBLE)

Pos./Pos.	Denomination	Product Identification No.	Pos.	Pos.
12	TEST CONNECTION	463 703 036 0		
11	TEST CONNECTION	463 703 115 0		
10	KIT	423 903 532 2		
9	TRISTOP BRAKE ACTUATOR	925 0		
8	2-WAY QUICK RELEASE VALVE	973 500 061 0		
7	TRAILER-MODULATOR	480 102 ... 0		
6	DRAIN VALVE	934 300 001 0		
5	HOSE CLAMP	451 999 ... 2	17	2
4	AIR RESERVOIR	950 0	16	1
3	PARK-RELEASE-EMERGENCY VALVE (PREV)	971 002 9... 0	15	1
2	COUPLING HEAD W. INT. LINE FILTER	952 201 ... 0	14	1
1	COUPLING HEAD W. INT. LINE FILTER	952 201 ... 0	13	2

Copyright: WABCO®		Part No.	Part No.	Part No.
2012-07-16	BURMESTER	2012-07-16	CHRONIS	BURMESTER
WABCO TRAILER - EBS E FOR 1-AXLE-SEMITRAILER 2S/2M				
Material No.:	841 701 201 0			
Part No.	Part No.	Part No.	Part No.	Part No.
4990	4990	4990	4990	4990

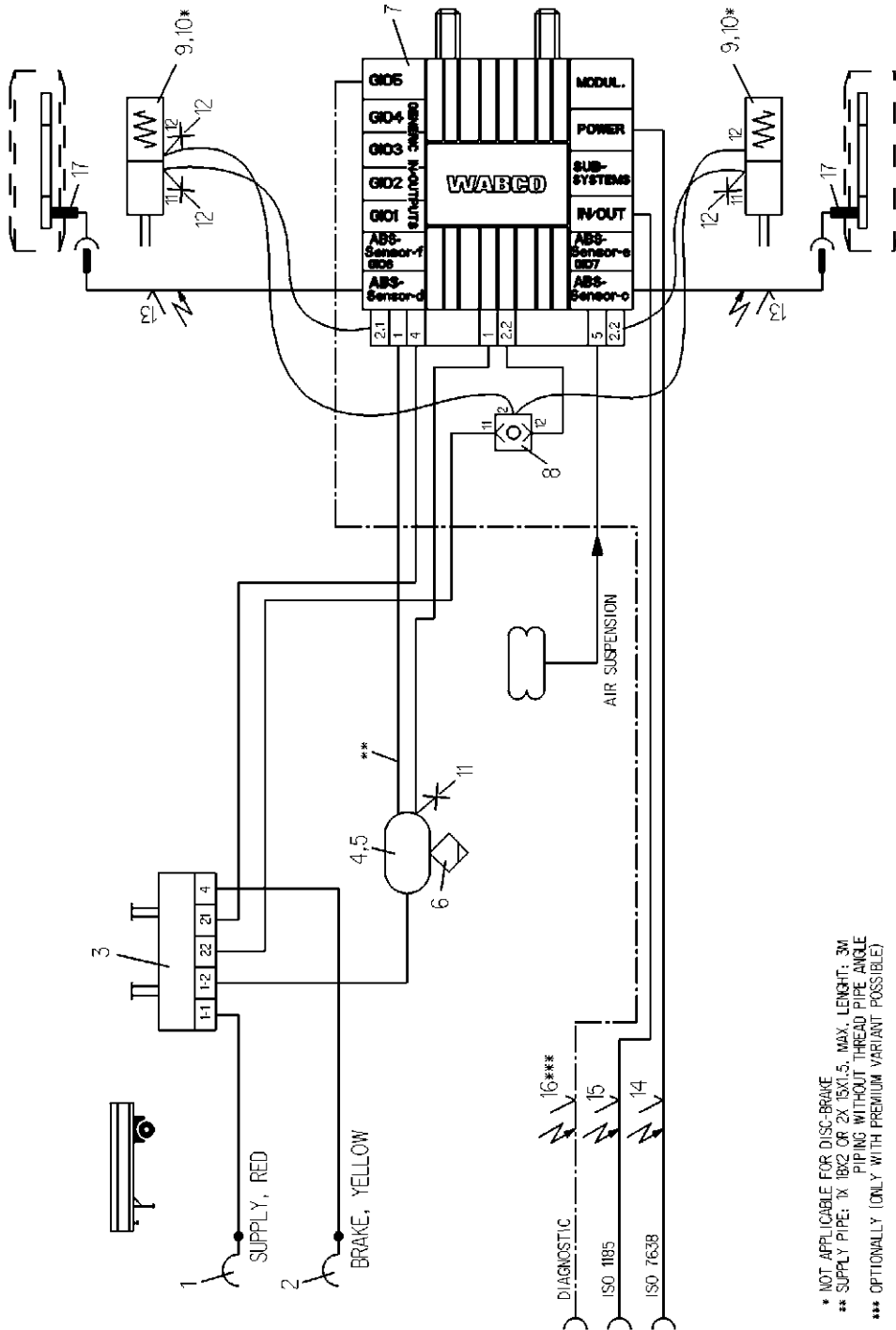

* NOT APPLICABLE FOR DISC-BRAKE
 ** SUPPLY PIPE: 1x 1/2" OR 2x 1/4" I.D., MAX. LENGTH: 3M
 PIPING WITHOUT THREAD PIPE ANGLE
 *** OPTIONALLY (ONLY WITH PREMIUM VARIANT POSSIBLE)

3		11		10		9		8		7		6		5		4		3		2		1			
Qty./Pcs.	Denomination	Qty./Pcs.	Denomination	Qty./Pcs.	Denomination	Qty./Pcs.	Denomination	Qty./Pcs.	Denomination	Qty./Pcs.	Denomination	Qty./Pcs.	Denomination	Qty./Pcs.	Denomination	Qty./Pcs.	Denomination	Qty./Pcs.	Denomination	Qty./Pcs.	Denomination	Qty./Pcs.	Denomination		
	TEST CONNECTION		463 703 036 0		463 703 115 0		423 903 532 2		925 0		434 204 0... 0		934 300 001 0		451 999 ... 2		990 0		971 002 9... 0		952 201 ... 0		952 201 ... 0		Product Identification No. 449 173 ... 0
	TEST CONNECTION		463 703 115 0		423 903 532 2		925 0		434 204 0... 0		934 300 001 0		451 999 ... 2		990 0		971 002 9... 0		952 201 ... 0		952 201 ... 0		952 201 ... 0		Product Identification No. 449 173 ... 0
	KIT		423 903 532 2		925 0		434 204 0... 0		934 300 001 0		451 999 ... 2		990 0		971 002 9... 0		952 201 ... 0		952 201 ... 0		952 201 ... 0		952 201 ... 0		Product Identification No. 449 173 ... 0
	TRISTOP BRAKE ACTUATOR		925 0		434 204 0... 0		934 300 001 0		451 999 ... 2		990 0		971 002 9... 0		952 201 ... 0		952 201 ... 0		952 201 ... 0		952 201 ... 0		952 201 ... 0		Product Identification No. 449 173 ... 0
	2-WAY VALVE		434 204 0... 0		934 300 001 0		451 999 ... 2		990 0		971 002 9... 0		952 201 ... 0		952 201 ... 0		952 201 ... 0		952 201 ... 0		952 201 ... 0		952 201 ... 0		Product Identification No. 449 173 ... 0
	TRAILER-MODULATOR		934 300 001 0		451 999 ... 2		990 0		971 002 9... 0		952 201 ... 0		952 201 ... 0		952 201 ... 0		952 201 ... 0		952 201 ... 0		952 201 ... 0		952 201 ... 0		Product Identification No. 449 173 ... 0
	HOSE CLAMP		451 999 ... 2		990 0		971 002 9... 0		952 201 ... 0		952 201 ... 0		952 201 ... 0		952 201 ... 0		952 201 ... 0		952 201 ... 0		952 201 ... 0		952 201 ... 0		Product Identification No. 449 173 ... 0
	AIR RESERVOIR		990 0		971 002 9... 0		952 201 ... 0		952 201 ... 0		952 201 ... 0		952 201 ... 0		952 201 ... 0		952 201 ... 0		952 201 ... 0		952 201 ... 0		952 201 ... 0		Product Identification No. 449 173 ... 0
	PARK-RELEASE-EMERGENCY VALVE (PREV)		971 002 9... 0		952 201 ... 0		952 201 ... 0		952 201 ... 0		952 201 ... 0		952 201 ... 0		952 201 ... 0		952 201 ... 0		952 201 ... 0		952 201 ... 0		952 201 ... 0		Product Identification No. 449 173 ... 0
	COUPLING HEAD W. INT. LINE FILTER		952 201 ... 0		952 201 ... 0		952 201 ... 0		952 201 ... 0		952 201 ... 0		952 201 ... 0		952 201 ... 0		952 201 ... 0		952 201 ... 0		952 201 ... 0		952 201 ... 0		Product Identification No. 449 173 ... 0
	COUPLING HEAD W. INT. LINE FILTER		952 201 ... 0		952 201 ... 0		952 201 ... 0		952 201 ... 0		952 201 ... 0		952 201 ... 0		952 201 ... 0		952 201 ... 0		952 201 ... 0		952 201 ... 0		952 201 ... 0		Product Identification No. 449 173 ... 0
	Denomination		Product Identification No. 463 703 036 0		Product Identification No. 463 703 115 0		Product Identification No. 423 903 532 2		Product Identification No. 925 0		Product Identification No. 434 204 0... 0		Product Identification No. 934 300 001 0		Product Identification No. 451 999 ... 2		Product Identification No. 990 0		Product Identification No. 971 002 9... 0		Product Identification No. 952 201 ... 0		Product Identification No. 952 201 ... 0		Product Identification No. 449 173 ... 0

WABCO

TRAILER - EBS E
 FOR 1-AXLE-SEMI TRAILER
 2S/2M

Doc. Code	1	Doc. Title	841 701 202 0
Doc. Code	002	Doc. Title	EN 1/1
Doc. Code	002	Doc. Title	EN 1/1

Material No.	841 701 202 0
Part No.	841 701 202 0
Part No.	841 701 202 0

Part No.	841 701 202 0
Part No.	841 701 202 0

Part No.	841 701 202 0
Part No.	841 701 202 0

Part No.	841 701 202 0
Part No.	841 701 202 0

Part No.	841 701 202 0
Part No.	841 701 202 0

Part No.	841 701 202 0
Part No.	841 701 202 0

Part No.	841 701 202 0
Part No.	841 701 202 0

Part No.	841 701 202 0
Part No.	841 701 202 0

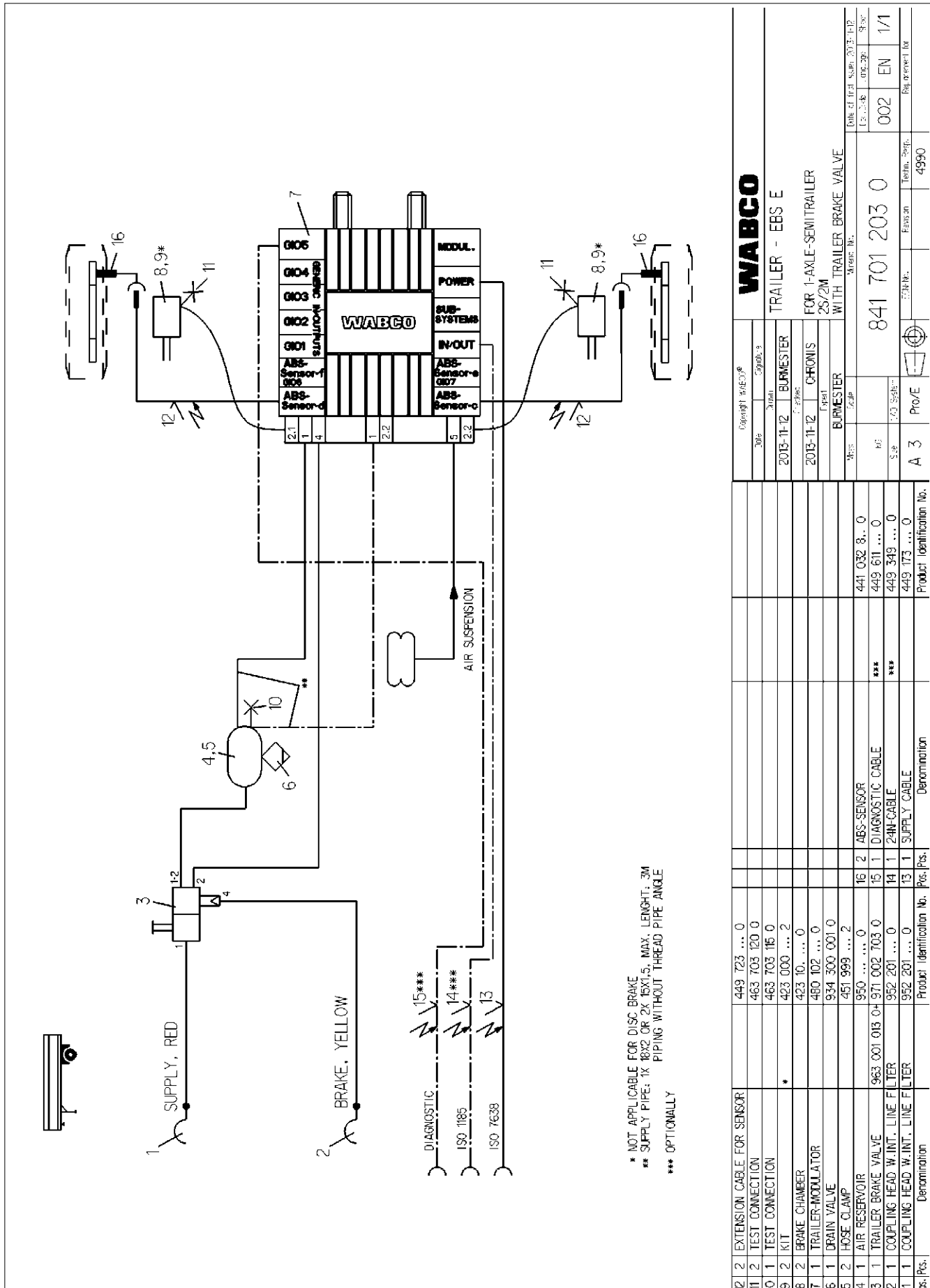

* NOT APPLICABLE FOR DISC BRAKE
 *** SUPPLY PIPE: 1X 18X2 OR 2X 15X1.5, MAX. LENGTH: 3M
 PIPING WITHOUT THREAD PIPE ANGLE
 *** OPTIONALLY

Copyright WABCO®		WABCO																	
Part No.	Signal No.	Part No.	Signal No.																
2013-11-12	BURMESTER	2013-11-12	CHRONIS																
FOR 1-AXLE-SEMITRILER 2S/2M		FOR 1-AXLE-SEMITRILER 2S/2M																	
WITH TRAILER BRAKE VALVE		WITH TRAILER BRAKE VALVE																	
<table border="1"> <tr> <td>Part No.</td> <td>Signal No.</td> <td>Part No.</td> <td>Signal No.</td> </tr> <tr> <td>441 032</td> <td>8... 0</td> <td>449 611</td> <td>... 0</td> </tr> <tr> <td>449 611</td> <td>... 0</td> <td>449 349</td> <td>... 0</td> </tr> <tr> <td>449 349</td> <td>... 0</td> <td>449 173</td> <td>... 0</td> </tr> </table>				Part No.	Signal No.	Part No.	Signal No.	441 032	8... 0	449 611	... 0	449 611	... 0	449 349	... 0	449 349	... 0	449 173	... 0
Part No.	Signal No.	Part No.	Signal No.																
441 032	8... 0	449 611	... 0																
449 611	... 0	449 349	... 0																
449 349	... 0	449 173	... 0																
Date of first issue: 2013-11-12		Date of first issue: 2013-11-12																	
13.000		13.000																	
002		EN																	
1/1		1/1																	
Requirement for		Requirement for																	
4990		4990																	

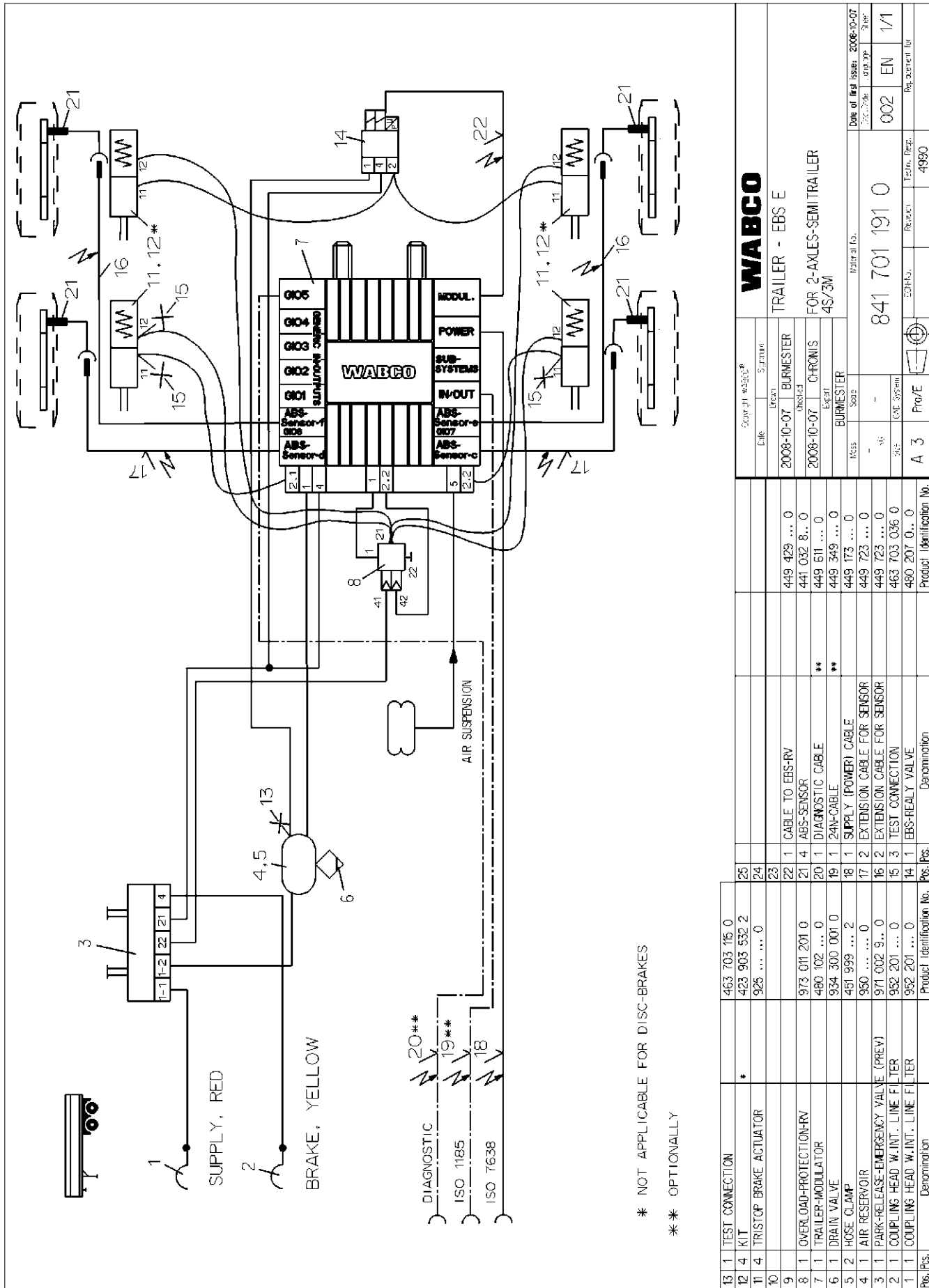

13	1	TEST CONNECTION	463 703 115 0	Product Identification No.	Pos./Pcs.	Denomination
12	4	KIT	423 903 532 2			
11	4	TRISTOP BRAKE ACTUATOR	925 0			
10						
9						
8	1	OVERLOAD-PROTECTION-RV	973 011 201 0			
7	1	TRAILER-MODULATOR	480 102 ... 0	**		
6	1	DRAIN VALVE	934 300 001 0	**		
5	2	HOSE CLAMP	451 999 ... 2			
4	1	AIR RESERVOIR	950 0			
3	1	PARK-RELEASE-EMERGENCY VALVE (PREV)	971 002 9.. 0			
2	1	COUPLING HEAD W.INT. LINE FILTER	952 201 ... 0			
1	1	COUPLING HEAD W.INT. LINE FILTER	952 201 ... 0			

25						
24						
23						
22	1	CABLE TO EBS-RV	449 429 ... 0			
21	4	ABS-SENSOR	441 032 8.. 0			
20	1	DIAGNOSTIC CABLE	449 611 ... 0	**		
19	1	24N-CABLE	449 349 ... 0	**		
18	1	SUPPLY (POWER) CABLE	449 173 ... 0			
17	2	EXTENSION CABLE FOR SENSOR	449 723 ... 0			
16	2	EXTENSION CABLE FOR SENSOR	449 723 ... 0			
15	3	TEST CONNECTION	463 703 036 0			
14	1	EBS-REALY VALVE	460 207 0.. 0			

WABCO TRAILER - EBS E FOR 2-AXLES-SEMI TRAILER 4S/3M		Date of first issue: 2008-10-07 Rev. Code: up to 07 002 EN 1/1 Reg. center for
2008-10-07 BURMESTER 2008-10-07 CHRONIS BURMESTER	841 701 191 0	4990
2008-10-07 2008-10-07 BURMESTER	449 429 ... 0 441 032 8.. 0 449 611 ... 0 449 349 ... 0 449 173 ... 0 449 723 ... 0 449 723 ... 0 463 703 036 0 460 207 0.. 0	Product Identification No.

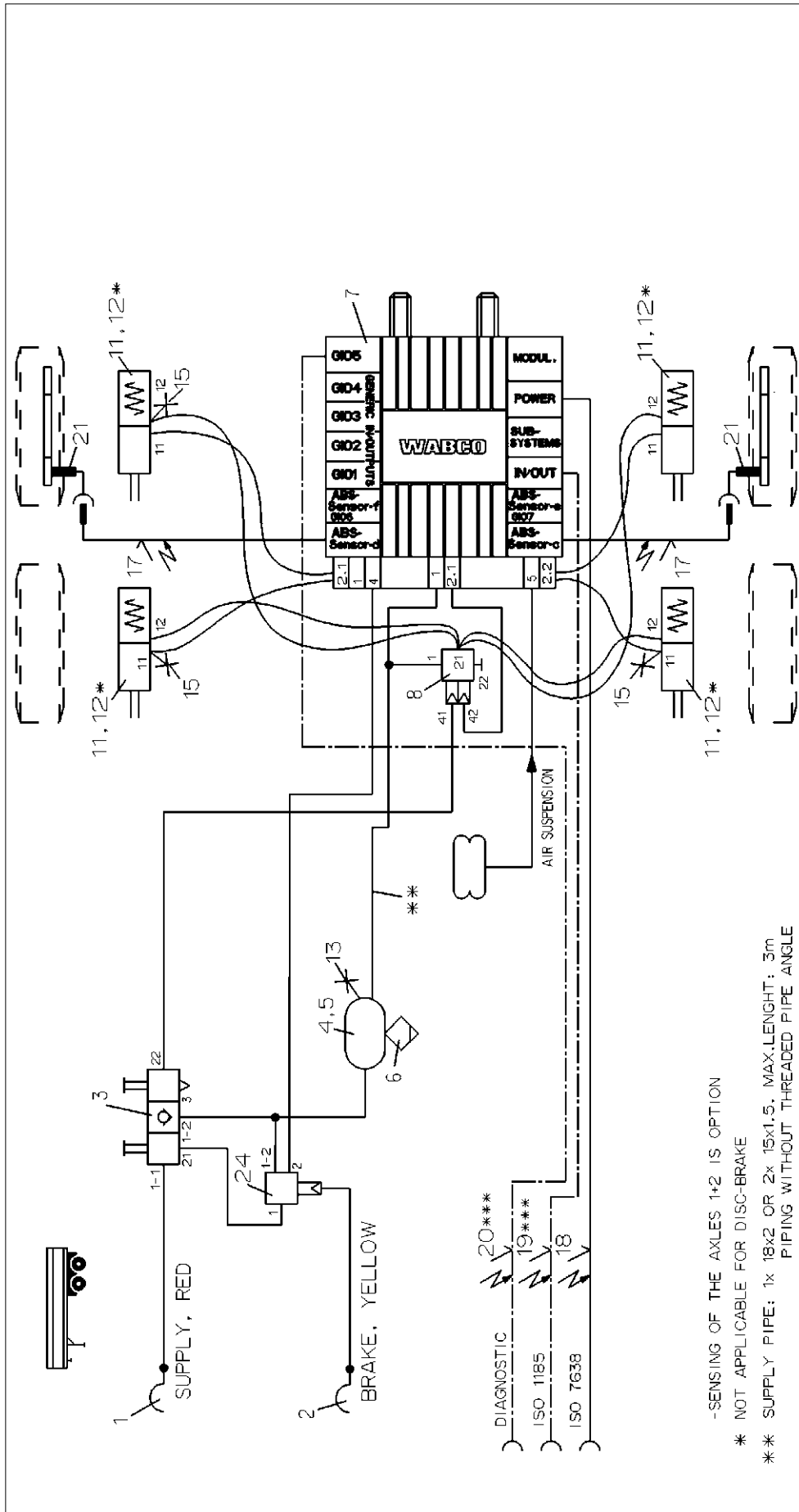

-SENSING OF THE AXLES 1+2 IS OPTION
 * NOT APPLICABLE FOR DISC-BRAKE
 ** SUPPLY PIPE: 1x 18x2 OR 2x 15x1.5, MAX. LENGTH: 3m
 PIPING WITHOUT THREADED PIPE ANGLE
 *** OPTIONALLY

WABCO TRAILER - EBS E FOR 2-AXLES-SEMITRAILER 2S/2M		Date of first issue: 2009-03-03 Issue No.: 0002/09 Revision: 1/1 Approval No.: 4990	
Date: 2009-03-03 Drawn: BURMESTER Checked: CHRONIS Part No.: 841 701 192 0 Title: TRAILER - EBS E	Product Identification No.: 971 002 301 0 Denomination:	Pos./Pcs.: Denomination:	Product Identification No.: 463 703 115 0 Denomination:

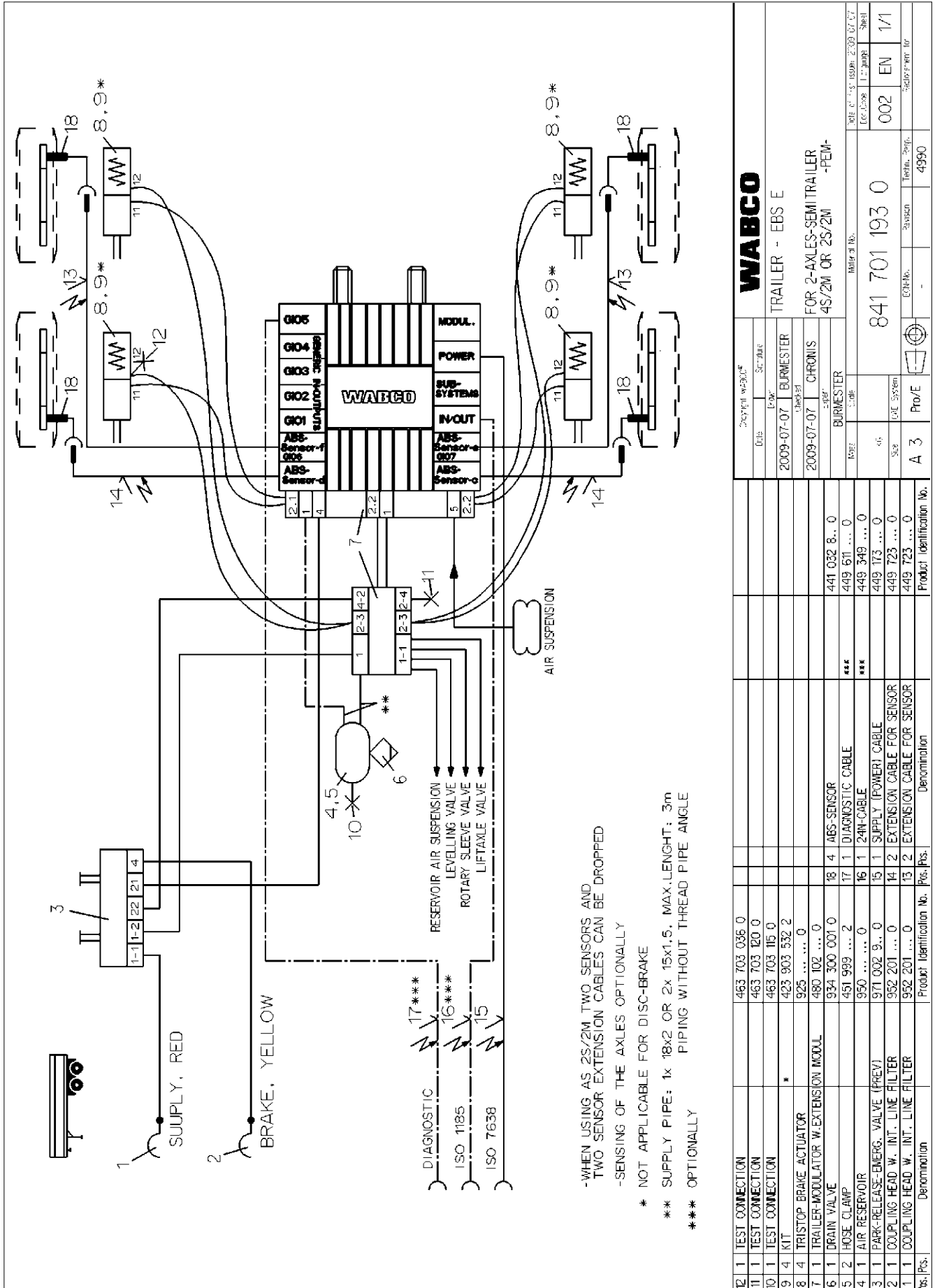

-WHEN USING AS 2S/2M TWO SENSORS AND TWO SENSOR EXTENSION CABLES CAN BE DROPPED
-SENSING OF THE AXLES OPTIONALLY
* NOT APPLICABLE FOR DISC-BRAKE
** SUPPLY PIPE: 1x 18x2 OR 2x 15x1,5, MAX.LENGTH: 3m
PIPING WITHOUT THREAD PIPE ANGLE
*** OPTIONALLY

Part no. WABCO*		
Qty	Part no.	Unit
12	463 703 036 0	TEST CONNECTION
11	463 703 120 0	TEST CONNECTION
10	463 703 115 0	TEST CONNECTION
9	423 903 532 2	KIT
8	925	TRISTOP BRAKE ACTUATOR
7	480 102 ... 0	TRAILER-MODULATOR W.EXTENSION MODUL
6	934 300 001 0	DRAIN VALVE
5	451 999 ... 2	HOSE CLAMP
4	950 0	AIR RESERVOIR
3	971 002 9... 0	PARK-RELEASE-EMERG. VALVE (PREV)
2	952 201 ... 0	COUPLING HEAD W. INT. LINE FILTER
1	952 201 ... 0	COUPLING HEAD W. INT. LINE FILTER
Pos./Pcs.	Denomination	Product Identification No. / Pcs./Pcs. / Denomination
12	463 703 036 0	TEST CONNECTION
11	463 703 120 0	TEST CONNECTION
10	463 703 115 0	TEST CONNECTION
9	423 903 532 2	KIT
8	925	TRISTOP BRAKE ACTUATOR
7	480 102 ... 0	TRAILER-MODULATOR W.EXTENSION MODUL
6	934 300 001 0	DRAIN VALVE
5	451 999 ... 2	HOSE CLAMP
4	950 0	AIR RESERVOIR
3	971 002 9... 0	PARK-RELEASE-EMERG. VALVE (PREV)
2	952 201 ... 0	COUPLING HEAD W. INT. LINE FILTER
1	952 201 ... 0	COUPLING HEAD W. INT. LINE FILTER
Pos./Pcs.	Denomination	Product Identification No. / Pcs./Pcs. / Denomination

WABCO
TRAILER - EBS E
FOR 2-AXLES-SEMI TRAILER
4S/2M OR 2S/2M -PEW-

Order No.	2009-07-07	BURMESTER
Part No.	2009-07-07	CHRONIS
Year		BURMESTER
Part No.	441 032 8... 0	ABS-SENSOR
Part No.	449 611 ... 0	DIAGNOSTIC CABLE
Part No.	449 349 ... 0	24IN-CABLE
Part No.	449 173 ... 0	SUPPLY (POWER) CABLE
Part No.	449 723 ... 0	EXTENSION CABLE FOR SENSOR
Part No.	449 723 ... 0	EXTENSION CABLE FOR SENSOR

Material No. 841 701 193 0
Rev. 002
EN 1/1
4990

841 701 195 0

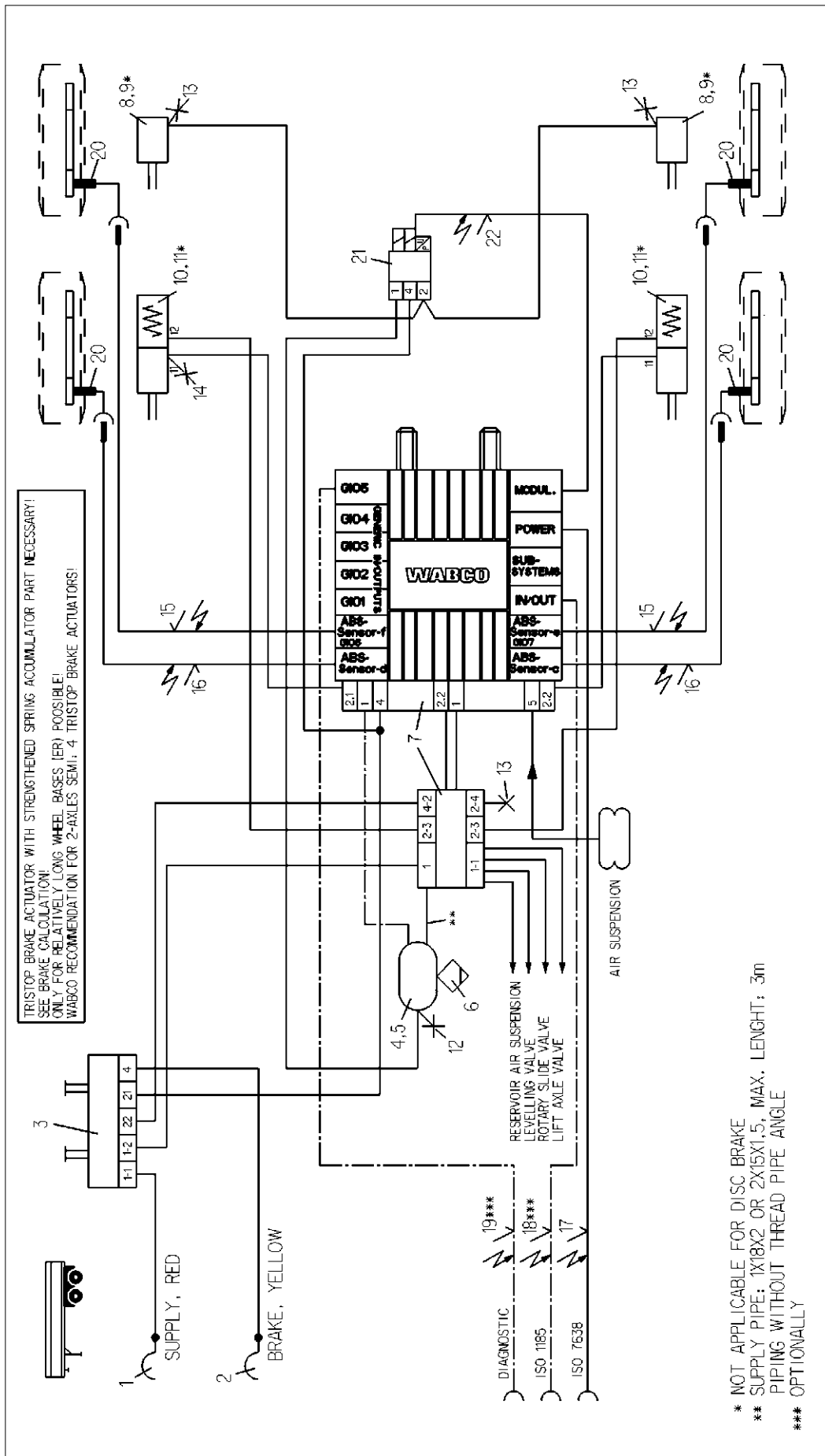

Original WABCO			WABCO		
Part No.	Symbol	Part No.	Part No.	Description	Part No.
449 429 ... 0		2010-03-15	BURMESTER	TRAILER - EBS E	
480 207 001 0		2010-03-15	CHRONIS	FOR 2-AXLES-SEMI-TRAILER	
441 032 8... 0					
449 611 ... 0		4S/3M		- WITH EXTENSION MODUL-	
449 349 ... 0		BURMESTER			
449 173 ... 0					
449 723 ... 0					
449 723 ... 0					
463 703 036 0					
463 703 120 0					
463 703 120 0					
Product Identification No.	841 701 195 0		Revision		002 EN 1/1
Product Identification No.	A 3		Part. No.		4990

* NOT APPLICABLE FOR DISC BRAKE
 ** SUPPLY PIPE: 1X18X2 OR 2X15X1,5, MAX. LENGTH: 3m
 PIPING WITHOUT THREAD PIPE ANGLE
 *** OPTIONALLY

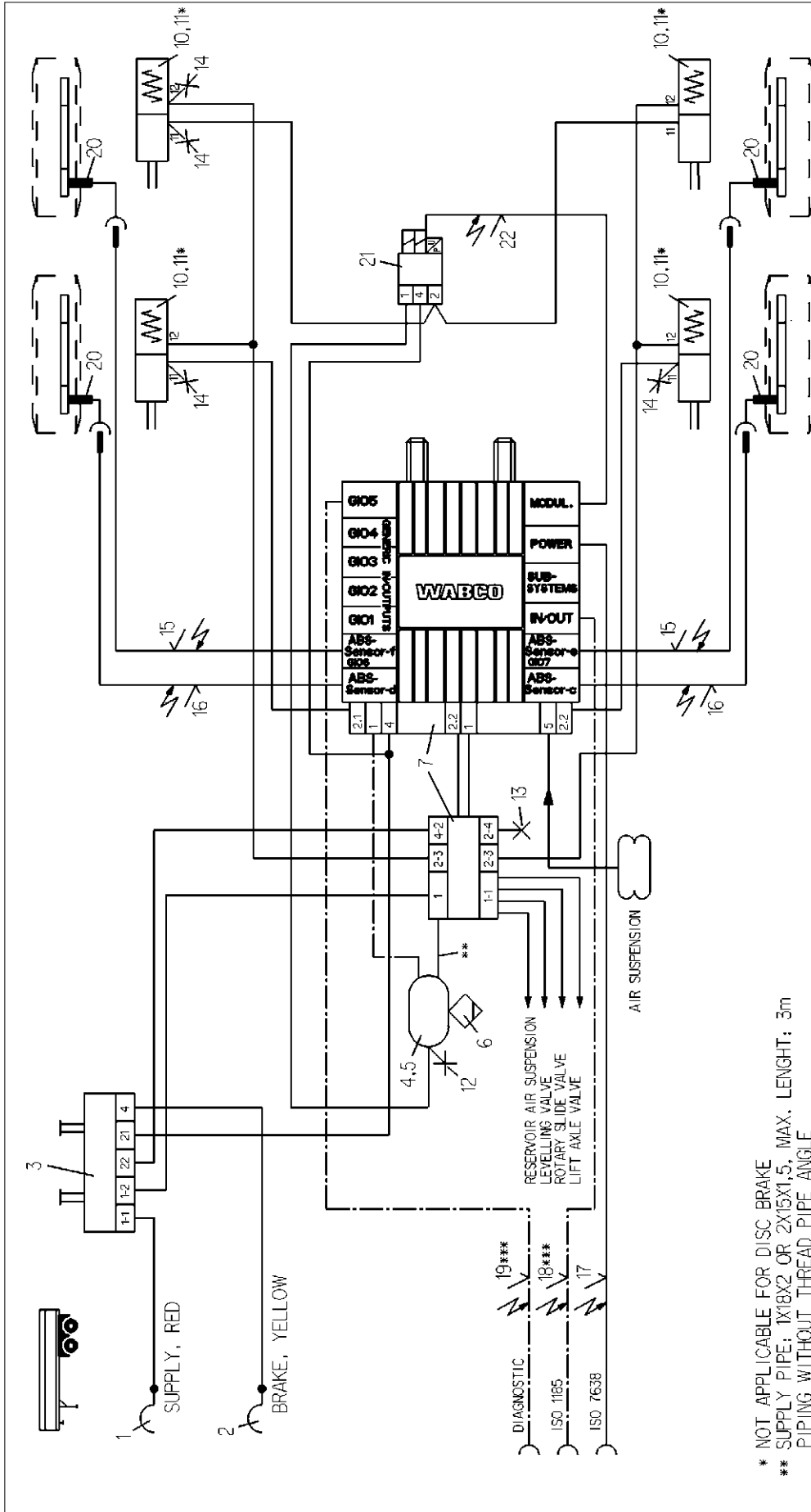

* NOT APPLICABLE FOR DISC BRAKE
 ** SUPPLY PIPE: 1X18X2 OR 2X15X1,5, MAX. LENGTH: 3m
 PIPING WITHOUT THREAD PIPE ANGLE
 *** OPTIONALLY

Part No.	Description	Qty	Part No.	Description	Qty
12	1 TEST CONNECTION	463 703 ... 0	12	1 TRAILER-MODULATOR w. EXTENSION MODUL.	480 102 ... 0
11	4 KIT	423 903 532 2	13	1 DRAIN VALVE	934 300 001 0
10	4 TRISTOP BRAKE ACTUATOR	925 ... 0	14	1 HOSE CLAMP	451 999 ... 2
9			15	1 AIR RESERVOIR	990 ... 0
8			16	1 PARK-RELEASE-EMERG.-VALVE (PREV)	971 002 9... 0
7	TRAILER-MODULATOR w. EXTENSION MODUL.	480 102 ... 0	17	1 COUPLING HEAD W. INT-LINE FILTER	952 201 001 0
6	1 DRAIN VALVE	934 300 001 0	18	1 TEST CONNECTION	463 703 036 0
5	2 HOSE CLAMP	451 999 ... 2	19	1 SUPPLY (POWER) CABLE	449 173 ... 0
4	1 AIR RESERVOIR	990 ... 0	20	2 EXTENSION CABLE FOR SENSOR	449 723 ... 0
3	1 PARK-RELEASE-EMERG.-VALVE (PREV)	971 002 9... 0	21	1 EXTENSION CABLE FOR SENSOR	449 723 ... 0
2	1 COUPLING HEAD W. INT-LINE FILTER	952 201 001 0	22	1 TEST CONNECTION	463 703 036 0
1	1 COUPLING HEAD W. INT-LINE FILTER	952 201 002 0			



TRAILER - EBS E
 FOR 2-AXLES-SEMI TRAILER
 4S/3M - PEM-
 841 701 196 0

Doc	Rev	Part No.	Part No.	Part No.	Part No.
2010-04-13	BURMESTER	449 429 ... 0	480 207 001 0	441 032 8... 0	449 611 ... 0
2010-04-13	CHRONIS	449 349 ... 0	449 173 ... 0	449 723 ... 0	463 703 036 0
BURMESTER	449 349 ... 0	449 173 ... 0	449 723 ... 0	449 723 ... 0	463 703 036 0
Part No.	Part No.	Part No.	Part No.	Part No.	Part No.
449 173 ... 0	449 723 ... 0	449 723 ... 0	449 723 ... 0	463 703 036 0	463 703 036 0
449 723 ... 0	449 723 ... 0	463 703 036 0	463 703 036 0	463 703 036 0	463 703 036 0

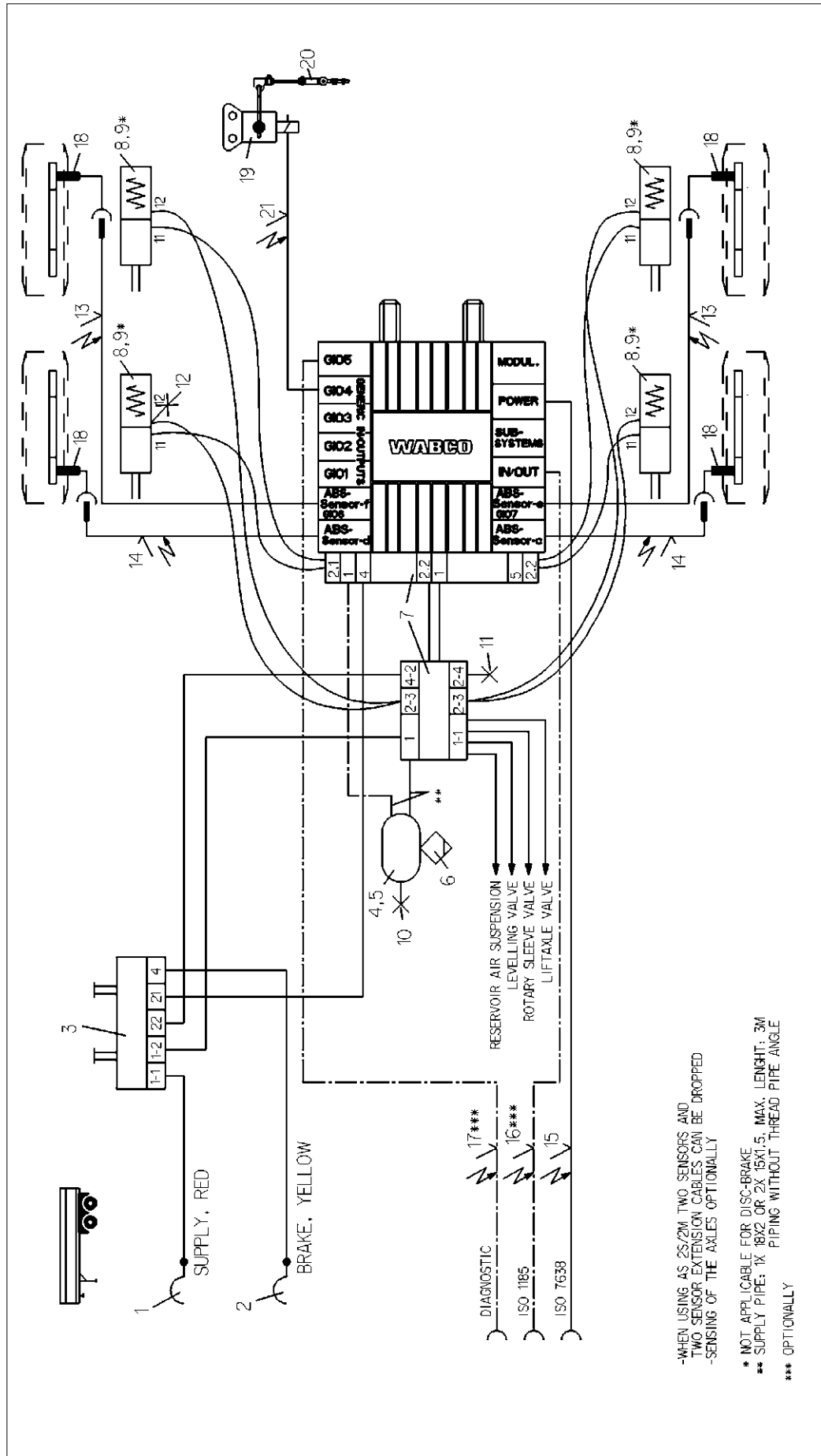

-WHEN USING AS 2S/2M TWO SENSORS AND TWO SENSOR EXTENSION CABLES CAN BE DROPPED
 -SENSING OF THE AXLES OPTIONALLY
 * NOT APPLICABLE FOR DISC-BRAKE
 ** SUPPLY PIPE: 1X 18X2 OR 2X 15X1,5. MAX. LENGTH: 3M
 PIPING WITHOUT THREAD PIPE ANGLE
 *** OPTIONALLY

Pos./Pcs.	Denomination	Product Identification No.	Pos./Pcs.	Denomination	Product Identification No.
12 1	TEST CONNECTION	463 703 036 0			
11 1	TEST CONNECTION	463 703 120 0			
10 1	TEST CONNECTION	463 703 115 0			
9 4	KIT	423 903 532 2	21 1	GIO-CABLE-DISTANCE SENSOR	449 811 ... 0
8 4	TRISTOP BRAKE ACTUATOR	925 ... 0	20 1	LINKAGE	433 401 003 0
7 1	TRAILER-MODULATOR W/ EXTENSION MODUL	480 102 ... 0	19 1	DISTANCE SENSOR	441 050 100 0
6 1	DRAIN VALVE	934 300 001 0	18 4	ABS-SENSOR	441 032 8... 0
5 2	HOSE CLAMP	451 999 ... 2	17 1	DIAGNOSTIC CABLE	449 611 ... 0
4 1	AIR RESERVOIR	950 ... 0	16 1	24N-CABLE	449 349 ... 0
3 1	PARK-RELEASE-EMERG. VALVE (PREV)	971 002 9... 0	15 1	SUPPLY (POWER) CABLE	449 173 ... 0
2 1	COUPLING HEAD W. INT. LINE FILTER	952 201 ... 0	14 2	EXTENSION CABLE FOR SENSOR	449 723 ... 0
1 1	COUPLING HEAD W. INT. LINE FILTER	952 201 ... 0	13 2	EXTENSION CABLE FOR SENSOR	449 723 ... 0

WABCO TRAILER - EBS E FOR 2-AXLES-SEMI TRAILER 4S/2M OR 2S/2M -PEM-		WABCO INC. 841 701 197 0 Part No. 4990
Job No. 2010-08-23 Draw No. BURMESTER Date 2010-08-23 Scale CHRONIS Version BURMESTER	Part No. 841 701 197 0 Part No. 002 Part No. EN Part No. 1/1	Date of Issue 2010-08-23 Date of Change Date of Approval

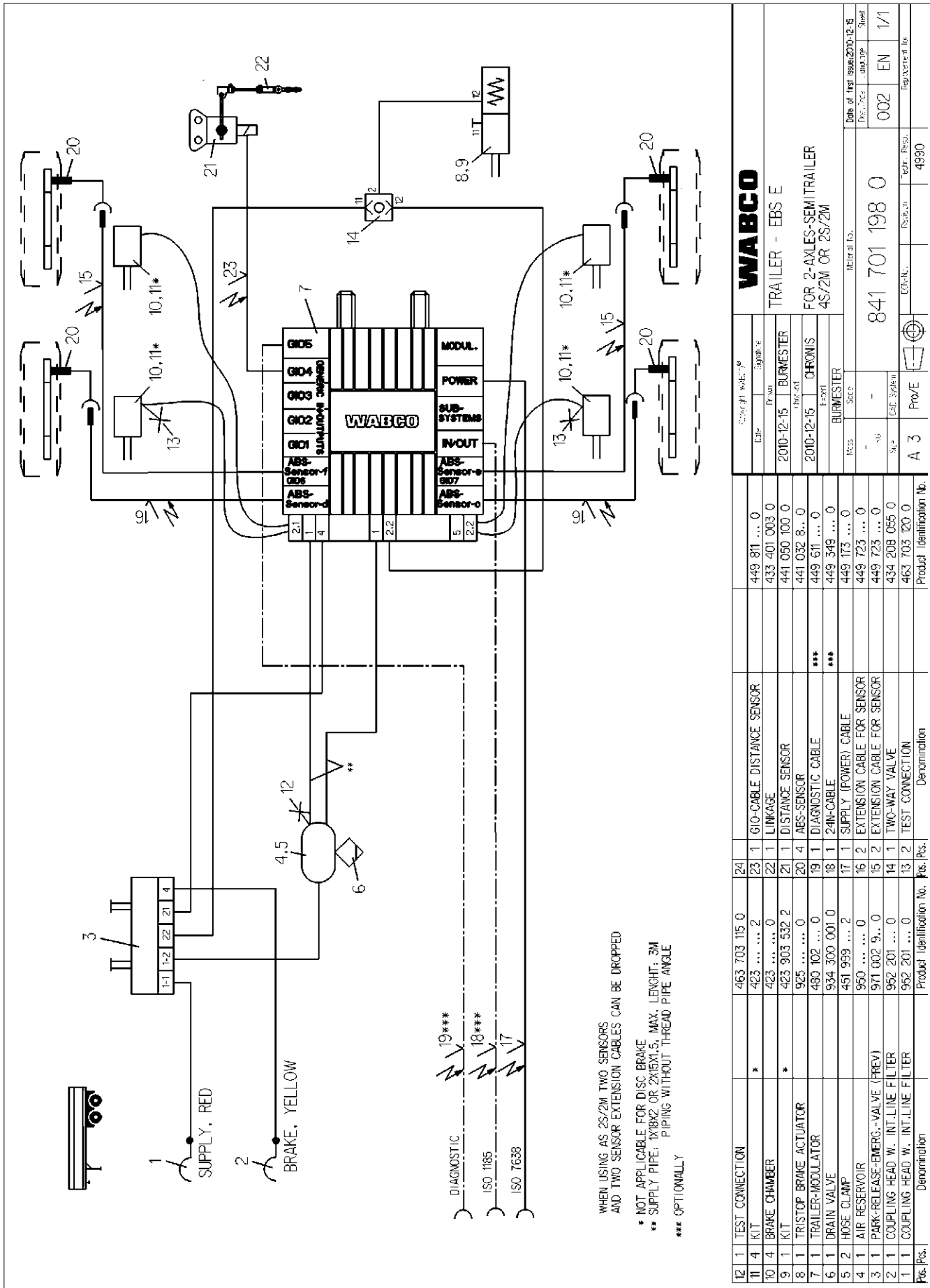

WABCO		Copyright WABCO	
Part No.	841 701 198 0	Part No.	841 701 198 0
Part Name	TRAILER - EBS E	Part Name	TRAILER - EBS E
Part Description	FOR 2-AXLES-SEMITRAILER	Part Description	FOR 2-AXLES-SEMITRAILER
Part Code	4S/2M OR 2S/2M	Part Code	4S/2M OR 2S/2M
Part Status	BURMESTER	Part Status	BURMESTER
Part Date	2010-12-15	Part Date	2010-12-15
Part Type	CHROMIS	Part Type	CHROMIS
Part Material	841 701 198 0	Part Material	841 701 198 0
Part Revision	002	Part Revision	002
Part Drawing	EN	Part Drawing	EN
Part Scale	1/1	Part Scale	1/1
Part Date of Issue	2010-12-15	Part Date of Issue	2010-12-15
Part Date of Rev.	002	Part Date of Rev.	002
Part Date of Exp.	EN	Part Date of Exp.	EN
Part Date of Rep.	4990	Part Date of Rep.	4990

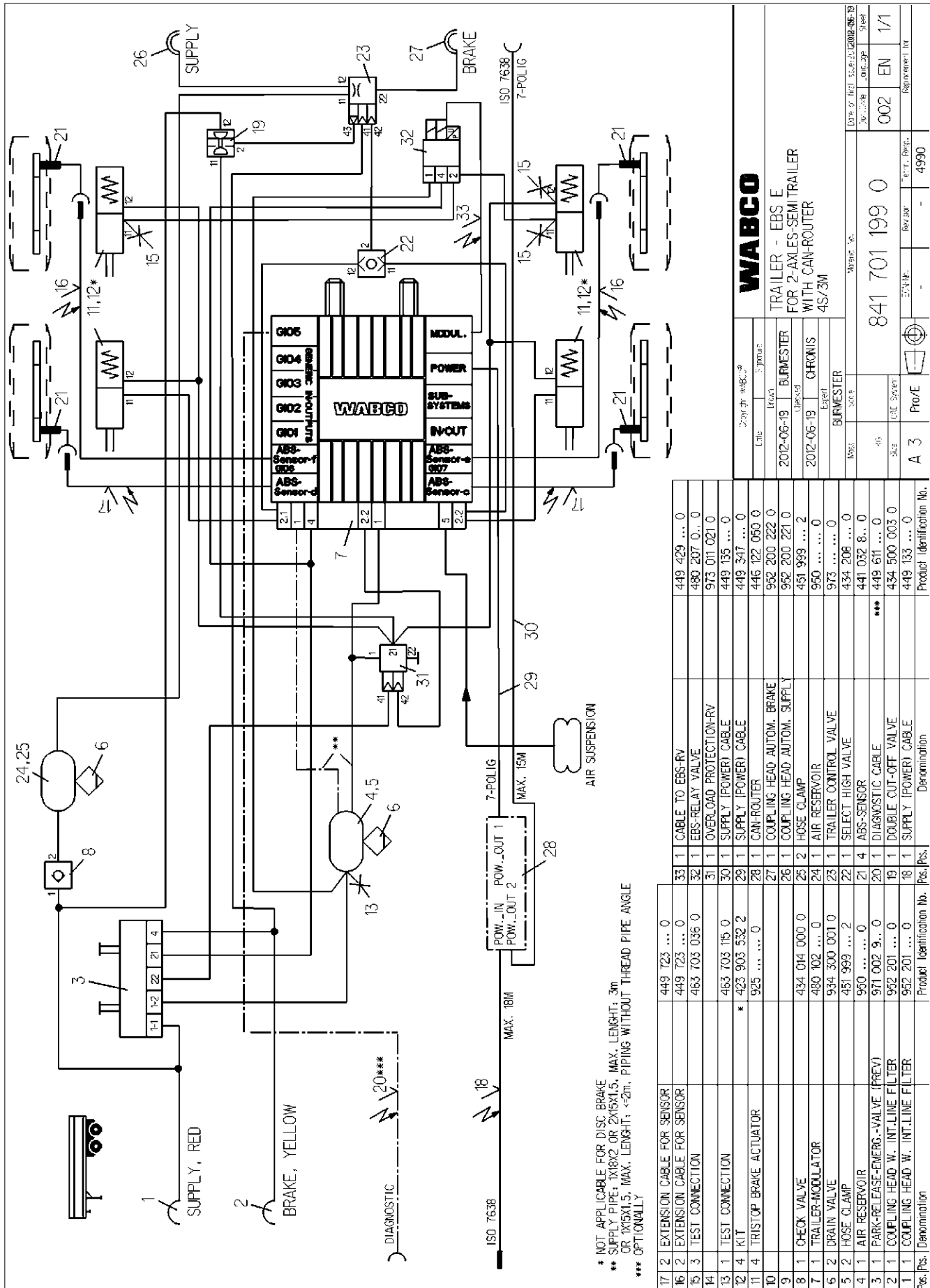

* NOT APPLICABLE FOR DISC BRAKE
 ** SUPPLY PIPE: 1X18X2, OR 2X15X1.5, MAX. LENGTH: 3m.
 OR 1X15X1.5, MAX. LENGTH: <2m. PIPING WITHOUT THREAD PIPE ANGLE
 *** OPTIONAL

17	2	EXTENSION CABLE FOR SENSOR	449 723 ... 0						
16	2	EXTENSION CABLE FOR SENSOR	449 723 ... 0	33	1	CABLE TO EBS-RV	449 429 ... 0		
15	3	TEST CONNECTION	463 703 036 0	32	1	EBS-RELAY VALVE	480 207 0... 0		
14				31	1	OVERLOAD PROTECTION-RV	973 011 021 0		
13	1	TEST CONNECTION	463 703 115 0	30	1	SUPPLY (POWER) CABLE	449 135 ... 0		
12	4	KIT	* 423 903 532 2	29	1	SUPPLY (POWER) CABLE	449 347 ... 0		
11	4	TRISTOP BRAKE ACTUATOR	925 0	28	1	CAN-ROUTER	446 122 050 0		
10				27	1	COUPLING HEAD, AUTOM. BRAKE	932 200 222 0		
9				26	2	COUPLING HEAD, AUTOM. SUPPLY	932 200 221 0		
8	1	CHECK VALVE	434 014 000 0	25	2	HOSE CLAMP	451 999 ... 2		
7	1	TRAILER-MODULATOR	480 102 ... 0	24	1	AIR RESERVOIR	950 0		
6	2	DRAIN VALVE	934 300 001 0	23	1	TRAILER CONTROL VALVE	973 0		
5	2	HOSE CLAMP	451 999 ... 2	22	1	SELECT HIGH VALVE	434 206 ... 0		
4	1	AIR RESERVOIR	950 0	21	4	ABS-SENSOR	441 032 8... 0		
3	1	PARK-RELEASE-EMERG.-VALVE (FREY)	971 002 9... 0	20	1	DIAGNOSTIC CABLE	449 611 ... 0		
2	1	COUPLING HEAD W. INT.LINE FILTER	932 201 ... 0	19	1	DOUBLE CUT-OFF VALVE	434 500 003 0		
1	1	COUPLING HEAD W. INT.LINE FILTER	932 201 ... 0	18	1	SUPPLY (POWER) CABLE	449 133 ... 0		
Pos./Pos.	Denomination	Product Identification No.	Pos./Pos.	Denomination	Product Identification No.	Pos./Pos.	Denomination	Product Identification No.	

WABCO
 TRAILER - EBS E
 FOR 2-AXLES-SEMI TRAILER
 WITH CAN-ROUTER
 4S/3M

Part No.	841 701 199 0	Rev. date	002	EN	1/1
Part No.	841 701 199 0	Rev. date			
Part No.	841 701 199 0	Rev. date			

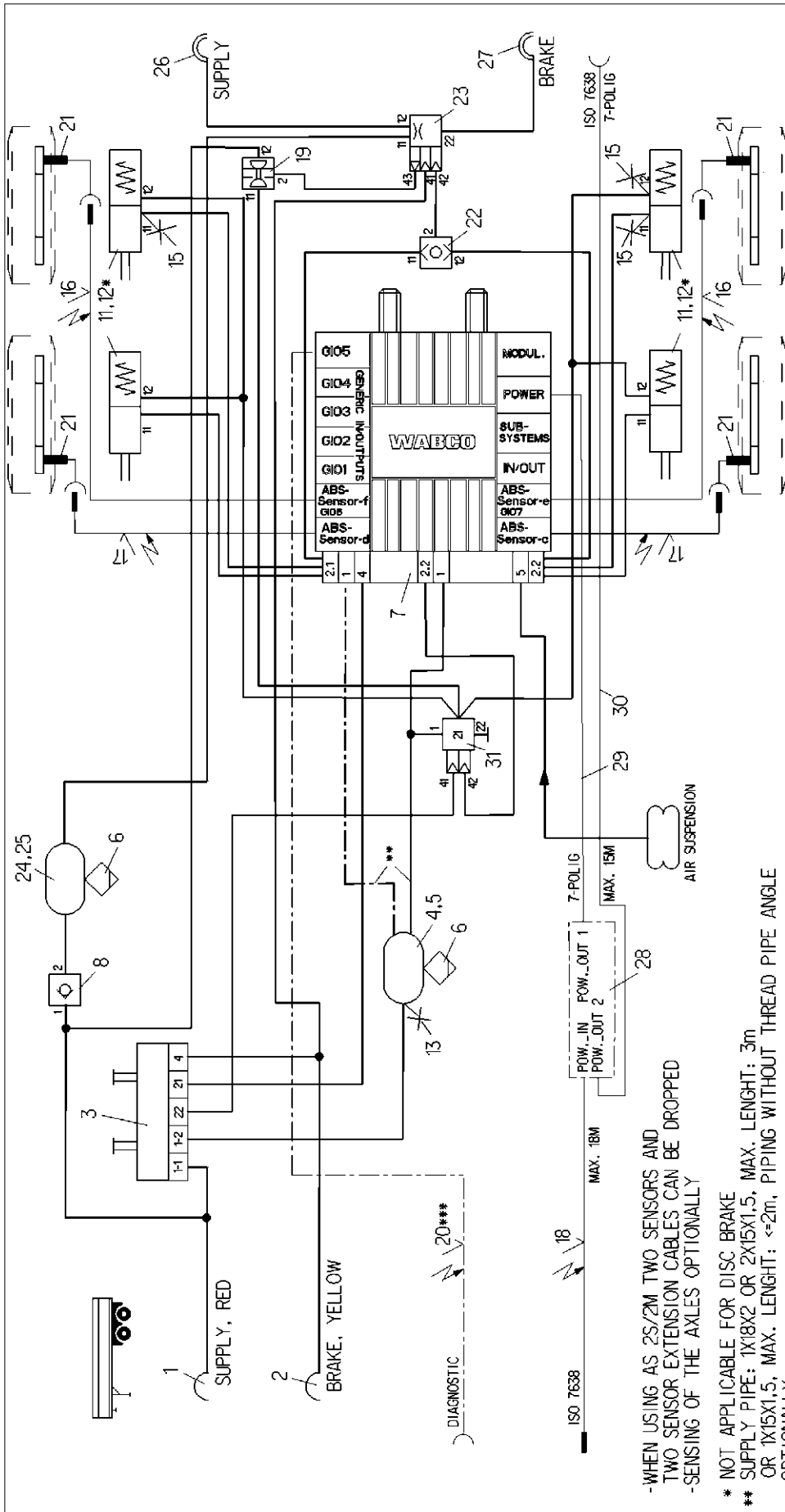

-WHEN USING AS 2S/2M TWO SENSORS AND TWO SENSOR EXTENSION CABLES CAN BE DROPPED
 -SENSING OF THE AXLES OPTIONALLY

* NOT APPLICABLE FOR DISC BRAKE
 ** SUPPLY PIPE: 1X18X2 OR 2X15X1.5, MAX. LENGTH: 3m OR 1X15X1.5, MAX. LENGTH: <=2m, PIPING WITHOUT THREAD PIPE ANGLE OPTIONALLY
 *** OPTIONAL

QTY	TEST CONNECTION	Part No.	Description	Denomination	Product Identification No.	Pos. Nos.
15	3	463 703 036 0	OVERLOAD PROTECTION-RV		973 011 201 0	
14	1	449 135 ... 0	SUPPLY (POWER) CABLE		449 347 ... 0	
13	1	463 703 115 0	CAN-ROUTER		446 122 050 0	
12	4	* 423 903 532 2	COUPLING HEAD AUTOM. BRAKE		952 200 222 0	
11	4	925 0	COUPLING HEAD AUTOM. SUPPLY		451 989 ... 2	
10	2		HOSE CLAMP		950 0	
9	1	434 014 000 0	AIR RESERVOIR		973 0	
8	1	480 102 ... 0	TRAILER CONTROL VALVE		434 208 ... 0	
7	1	934 300 001 0	SELECT HIGH VALVE		441 032 8... 0	
6	2	451 999 ... 2	ABS-SENSOR		*** 449 611 ... 0	
5	2	950 0	DIAGNOSTIC CABLE		434 500 003 0	
4	1	971 002 9... 0	AIR RESERVOIR		449 133 ... 0	
3	1	952 201 ... 0	PARK-RELEASE-EMERG.-VALVE (PREV)		449 723 ... 0	
2	1	952 201 ... 0	COUPLING HEAD W. INT.-LINE FILTER		449 723 ... 0	
1	1	952 201 ... 0	EXTENSION CABLE FOR SENSOR			

INDEX	DATE	DESCRIPTION OF CHANGE
A	2014-04-02	973 011 021 0 CHANGED INTO 973 011 201 0

WABCO
 TRAILER - EBS E
 FOR 2-AXLES-SEMI TRAILER
 WITH CAN-ROUTER
 4S/2M OR 2S/2M

2012-06-19 | BURMESTER
 2012-06-19 | CHRONIS

Part No. 841 701 270 0
 Rev. 002
 Date of first issue: 2012-06-19

Material No. 841 701 270 0
 Part No. 841 701 270 0
 Rev. 002
 Date of first issue: 2012-06-19

Part No. A
 Rev. 002
 Date of first issue: 2012-06-19

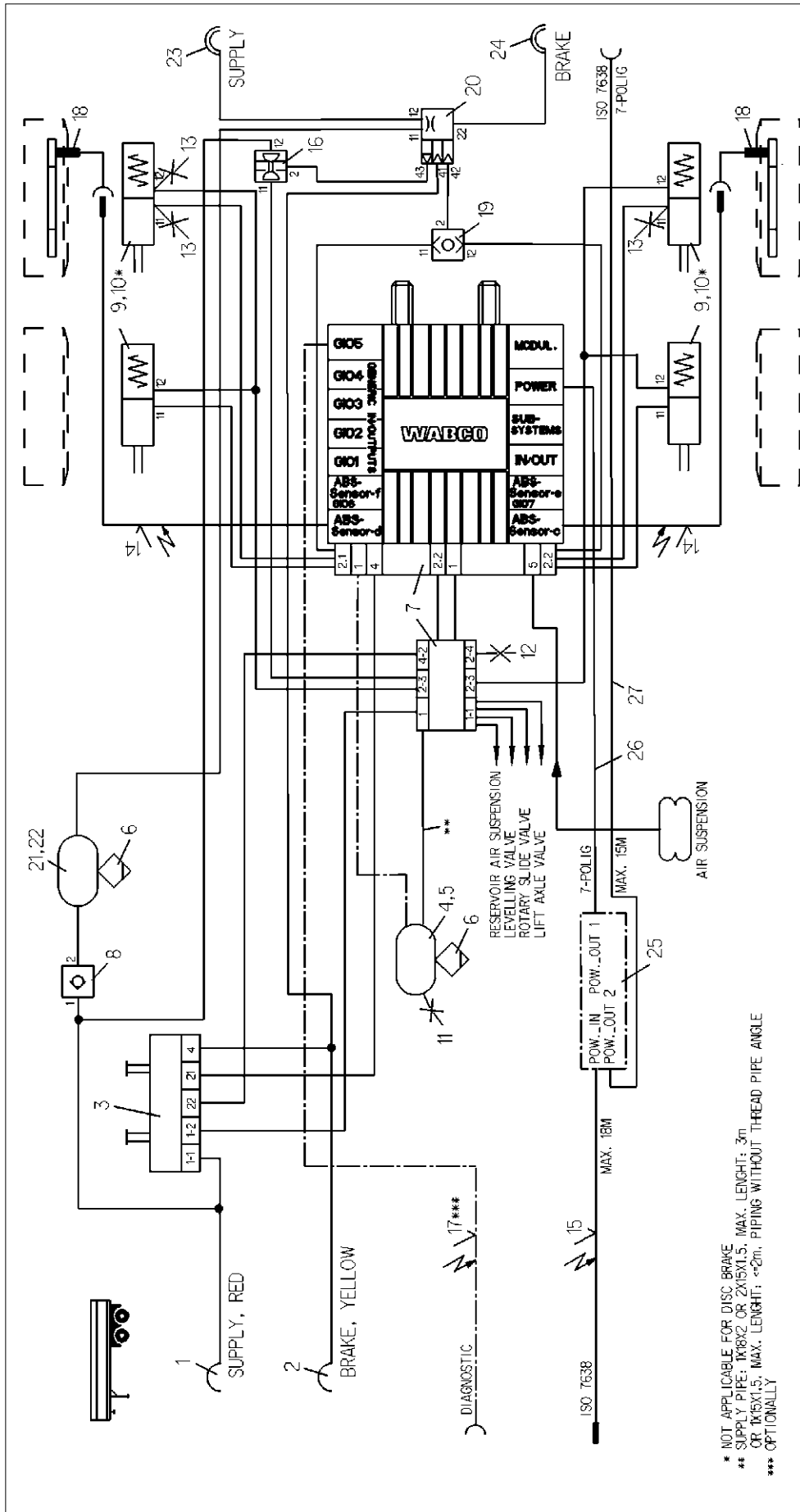

* NOT APPLICABLE FOR DISC BRAKE
 ** SUPPLY PIPE: 1X18X2 OR 2X15X1.5, MAX. LENGTH: 3m
 OR 1X6X1.5, MAX. LENGTH: $\leq 2\text{m}$, PIPING WITHOUT THREAD PIPE ANGLE
 *** OPTIONALLY

Pos./Pos.	Denomination	Product Identification No.	Pos./Pos.	Denomination	Product Identification No.
14	2 EXTENSION CABLE FOR SENSOR	449 723 ... 0	28		
13	3 TEST CONNECTION	463 703 036 0	27	1 SUPPLY (POWER) CABLE	449 135 ... 0
12	1 TEST CONNECTION	463 703 120 0	26	1 SUPPLY (POWER) CABLE	449 347 ... 0
11	1 TEST CONNECTION	463 703 115 0	25	1 CAN-ROUTER	446 122 050 0
10	4 KIT	* 423 903 532 2	24	1 COUPLING HEAD AUTOM. BRAKE	952 200 222 0
9	4 TRISTOP BRAKE ACTUATOR	925 ... 0	23	1 COUPLING HEAD AUTOM. SUPPLY	952 200 221 0
8	1 CHECK VALVE	434 014 000 0	22	2 HOSE CLAMP	451 999 ... 2
7	1 TRAILER-MODULATOR W-EXTENSION MODUL	480 102 ... 0	21	1 AIR RESERVOIR	950 ... 0
6	2 DRAIN VALVE	934 300 001 0	20	1 TRAILER CONTROL VALVE	973 ... 0
5	2 HOSE CLAMP	461 999 ... 2	19	1 TWO WAY VALVE	434 208 02 0
4	1 AIR RESERVOIR	950 ... 0	18	2 ABS-SENSOR	441 032 8 0
3	1 PARK-RELEASE-EMERG.-VALVE (PREV)	971 002 9 ... 0	17	1 DIAGNOSTIC CABLE	449 611 ... 0
2	1 COUPLING HEAD W. INT.LINE FILTER	952 201 ... 0	16	1 DOUBLE OUT-OFF VALVE	434 500 003 0
1	1 COUPLING HEAD W. INT.LINE FILTER	952 201 ... 0	15	1 SUPPLY (POWER) CABLE	449 133 ... 0

WABCO TRAILER - EBS E FOR 2-AXLES-SEMI TRAILER WITH CAN-ROUTER 2S/2M		Date of first issue: 202-07-11 Edition: 002 Sheet: EN 1/1
Part No.: 841 701 271 0 Rev. No.: A 3 Pro/E	Part No.: 4990 Rev. No.: 002 Subcontractor:	Material No.: Part No.: Rev. No.:

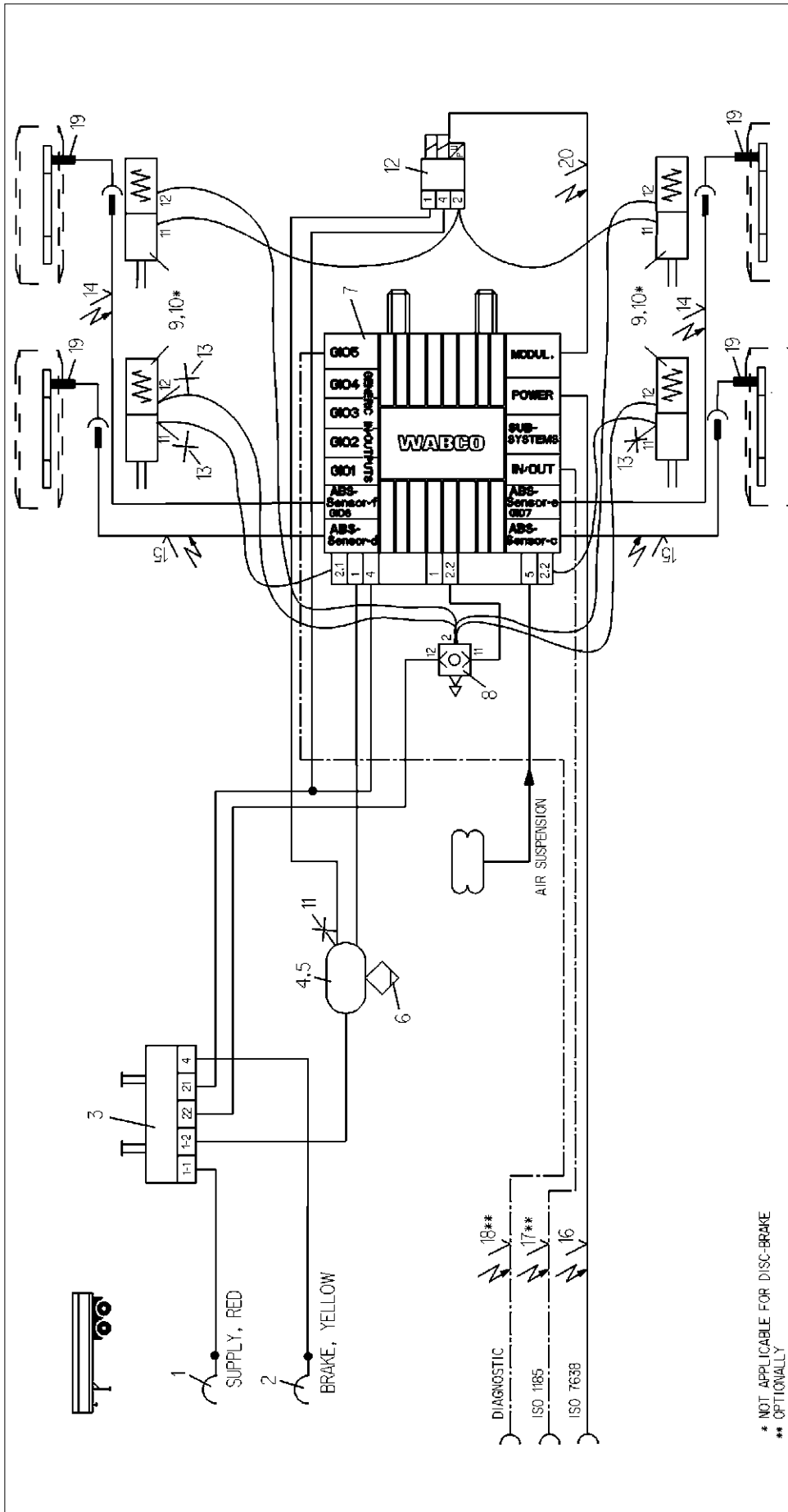

* NOT APPLICABLE FOR DISC-BRAKE
 ** OPTIONALLY

Country		WABCO®		Part No.		Description		Revision		Date of Issue	
File	Signature	Year	Month	Day	Hour	Minute	Second	Year	Month	Day	Hour
2012-07-10	BURMESTER	Checked									
2012-07-10	CHRONIS	Checked									
WABCO		TRAILER - EBS E		841 701 272 0		FOR 2-AXLES-SEMI TRAILER		002		EN 1/1	
4S/3M											
BURMESTER		Mater. No.		841 701 272 0		Tech. Pers.		4890			
A 3		Prov/E		CONTR.		Revised					
Product Identification No.		480 207 0.. 0		24		EBS-RELAY VALVE					
Product Identification No.		463 703 115 0		23		TEST CONNECTION					
Product Identification No.		423 903 532 2		22		KIT					
Product Identification No.		925 0		21		TRISTOP BRAKE ACTUATOR					
Product Identification No.		973 500 051 0		20		2-WAY QUICK RELEASE VALVE					
Product Identification No.		480 102 .. 0		19		TRAILER-MODULATOR					
Product Identification No.		934 300 001 0		18		DRAIN VALVE					
Product Identification No.		451 999 ... 2		17		HOSE CLAMP					
Product Identification No.		950 0		16		AIR RESERVOIR					
Product Identification No.		971 002 9.. 0		15		PARK-RELEASE-EMERGENCY VALVE (PREV)					
Product Identification No.		952 201 ... 0		14		COUPLING HEAD W.INT. LINE FILTER					
Product Identification No.		952 201 ... 0		13		COUPLING HEAD W.INT. LINE FILTER					
Product Identification No.		463 703 036 0		12		TEST CONNECTION					
Product Identification No.		449 429 ... 0		11		CABLE TO EBS-RV					
Product Identification No.		441 032 8.. 0		10		ABS-SENSOR					
Product Identification No.		449 611 ... 0		9		DIAGNOSTIC CABLE					
Product Identification No.		449 349 ... 0		8		24V-CABLE					
Product Identification No.		449 173 ... 0		7		SUPPLY (POWER) CABLE					
Product Identification No.		449 723 ... 0		6		EXTENSION CABLE FOR SENSOR					
Product Identification No.		449 723 ... 0		5		EXTENSION CABLE FOR SENSOR					
Product Identification No.		463 703 036 0		4		TEST CONNECTION					
Product Identification No.		463 703 036 0		3		TEST CONNECTION					
Product Identification No.		463 703 036 0		2		TEST CONNECTION					
Product Identification No.		463 703 036 0		1		TEST CONNECTION					

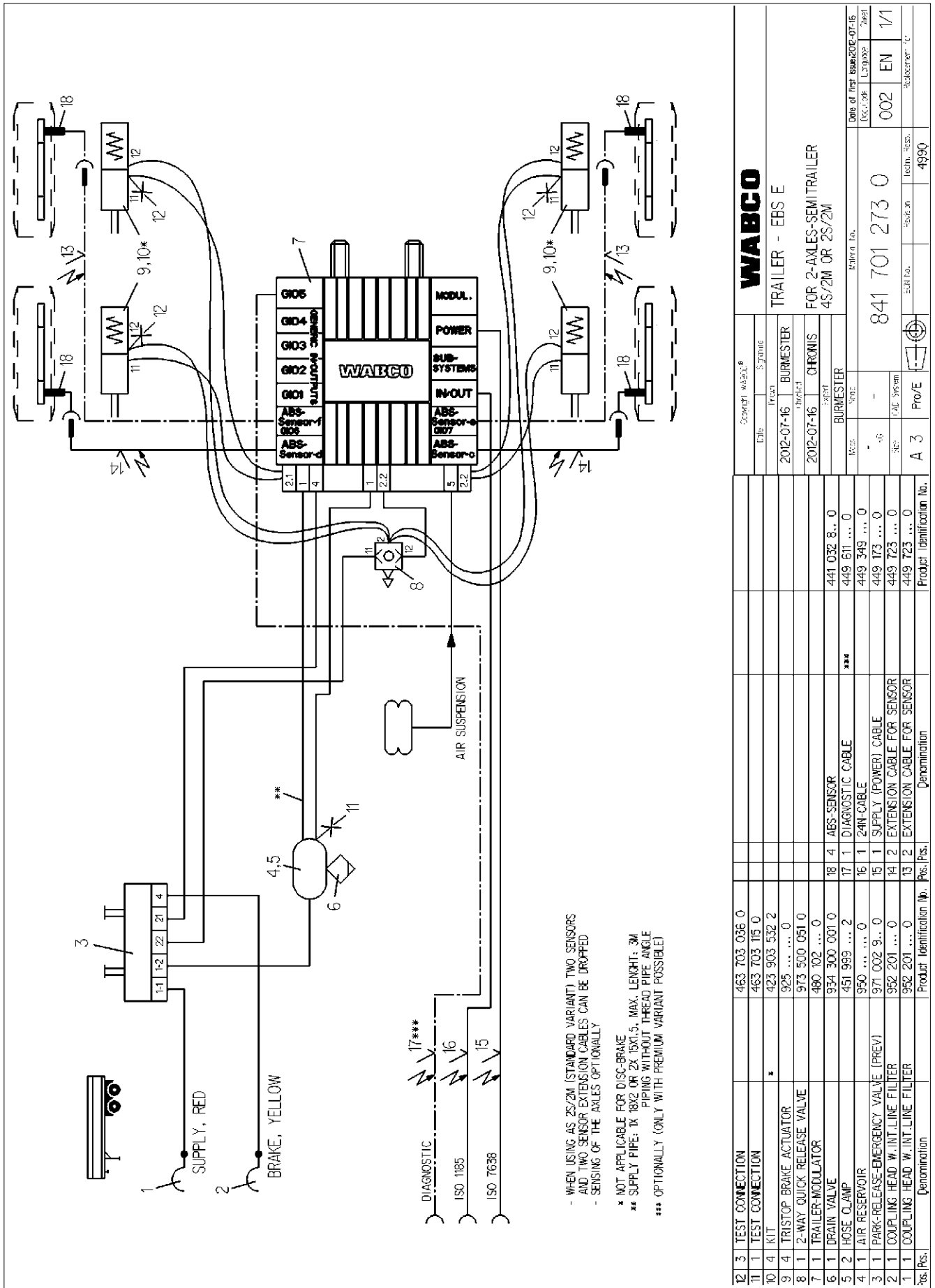

- WHEN USING AS 2S/2M (STANDARD VARIANT) TWO SENSORS AND TWO SENSOR/EXTENSION CABLES CAN BE DROPPED - SENSING OF THE AXLES OPTIONALLY
 * NOT APPLICABLE FOR DISC-BRAKE
 ** SUPPLY PIPE: 1X 8X2 OR 2X 15X1,5, MAX. LENGTH: 3M PIPING WITHOUT THREAD PIPE ANGLE
 *** OPTIONALLY (ONLY WITH PREMIUM VARIANT POSSIBLE)

WABCO
 TRAILER - EBS E
 FOR 2-AXLES-SEMITRAILER
 4S/2M OR 2S/2M

part no. 841 701 273 0
 Date of first issue 2012-07-16

Pro/E A 3
 Rev. 16
 Rev. 26

4990

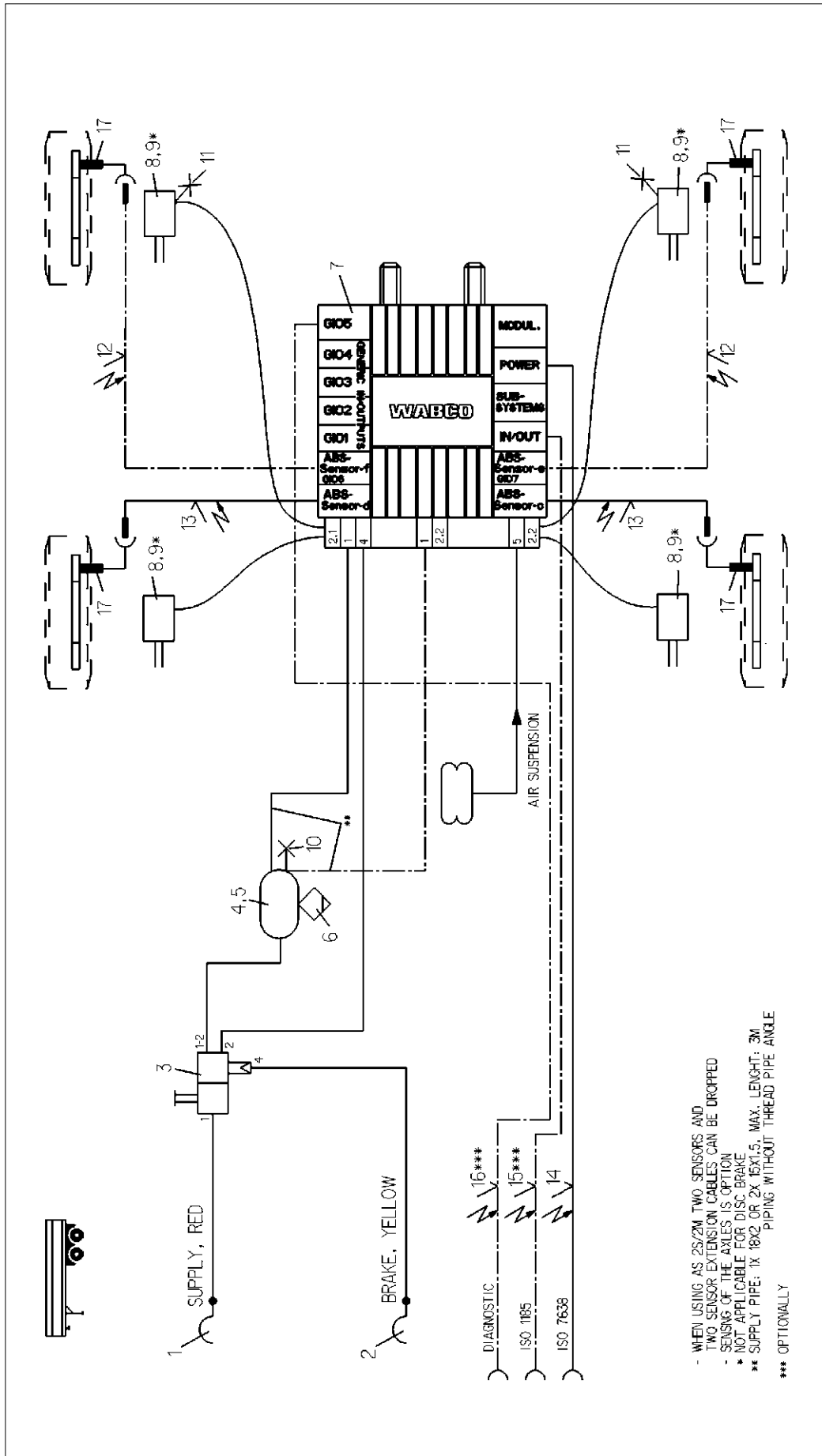

- WHEN USING AS 2S/2M TWO SENSORS AND TWO SENSOR EXTENSION CABLES CAN BE DROPPED
 - SENSING OF THE AXLES IS OPTION
 - NOT APPLICABLE FOR DISC BRAKE
 ** SUPPLY PIPE: 1X 18X2 OR 2X 15X1.5, MAX. LENGTH: 3M
 PIPING WITHOUT THREAD PIPE ANGLE
 *** OPTIONALLY

Copyright WABCO®		Signature	
Part No.	Order Code	Part No.	Order Code
2013-09-25	BURMESTER		
2013-09-25	CHRONIS		
FOR 2-AXLES-SEMITRAILER 4S/2M OR 2S/2M WITH TRAILER BRAKE VALVE		WABCO Part No.	
841 701 276 0		Part No.	Order Code
		841 701 276 0	002 EN 1/1
		Part No.	Order Code
		4990	4990

Product Identification No.	Qty.	Description
449 723 ... 0	17	4 ABS-SENSOR
463 703 120 0	16	1 DIAGNOSTIC CABLE
463 703 115 0	15	1 24M-CABLE
423 000 ... 2	14	1 SUPPLY CABLE
423 10 ... 0	13	2 EXTENSION CABLE FOR SENSOR
934 300 001 0	1	1 TRAILER-MODULATOR
451 999 ... 2	1	1 HOSE CLAMP
950 ... 0	1	1 AIR RESERVOIR
963 001 013 0	1	1 TRAILER BRAKE VALVE
952 201 ... 0	1	1 COUPLING HEAD W.INT. LINE FILTER
952 201 ... 0	1	1 COUPLING HEAD W.INT. LINE FILTER

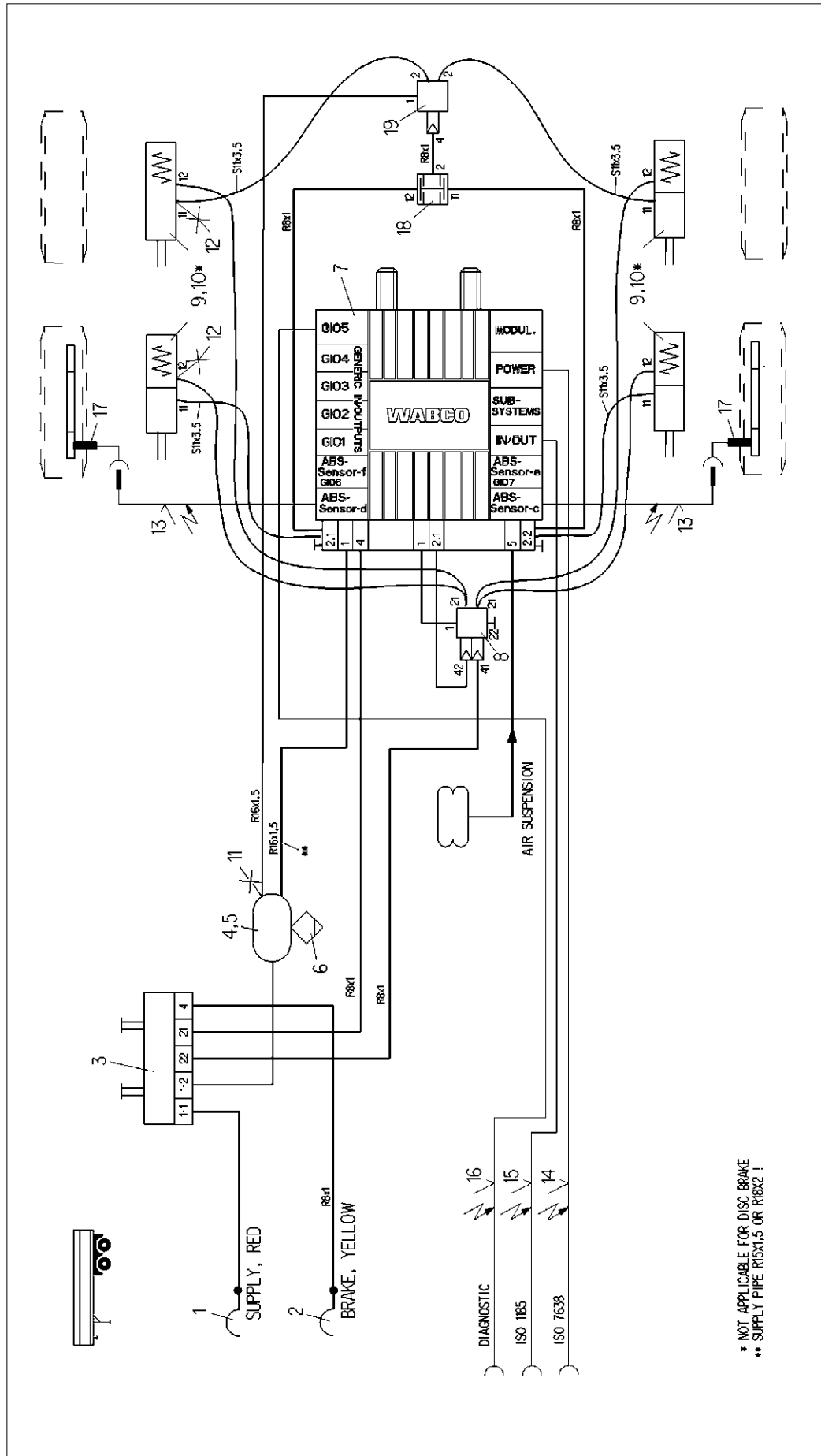

* NOT APPLICABLE FOR DISC BRAKE
 ** SUPPLY PIPE R8x1,5 OR R8x2 !

Qty./Pcs.	Denomination	Product Identification No.	Pcs./Pcs.	Denomination	Product Identification No.
12	TEST CONNECTION	463 703 ... 0	24		
11	TEST CONNECTION	463 703 ... 0	23		
10	4 KIT	423 903 532 2	22		
9	TRISTOP BRAKE ACTUATOR	925 ... 0	21		
9	4 TRISTOP-PROTECTION-RV	973 011 201 0	20		
8	1 TRAILER-MODULATOR	480 702 ... 0	19	1 RELAY VALVE	973 011 ... 0
6	1 DRAIN VALVE	934 300 001 0	18	1 DOUBLE SHUTT-OFF VALVE	434 500 003 0
5	2 HOSE CLAMP	451 999 ... 2	17	2 ABS-SENSOR	441 032 8... 0
4	1 AIR RESERVOIR	950 ... 0	16	1 DIAGNOSTIC CABLE	449 611 ... 0
3	1 PARK-RELEASE-EMERGENCY VALVE (PREV)	971 002 9... 0	15	1 24H-CABLE	449 349 ... 0
2	1 COUPLING HEAD W. INT. LINE FILTER	962 201 ... 0	14	1 SUPPLY (POWER) CABLE	449 173 ... 0
1	1 COUPLING HEAD W. INT. LINE FILTER	952 201 ... 0	13	2 EXTENSION CABLE FOR SENSOR	449 723 ... 0

Copyright WABCO®		Date		2014-11-24	
Signature		Drawn		BURMESTER	
Checked		Approved		C-GRONIS	
Title		Eben		BURMESTER	
Mass		Kg		-	
S/N		CAD Style		-	
A 3		CREO		841 701 277 0	
Product Identification No.		Revision		002 EN 1/1	
Denomination		Termin. Spec.		4990	
HMR 00495		Date of first issue: 2014-11-24		Doc. Lock	
		Library		Check	

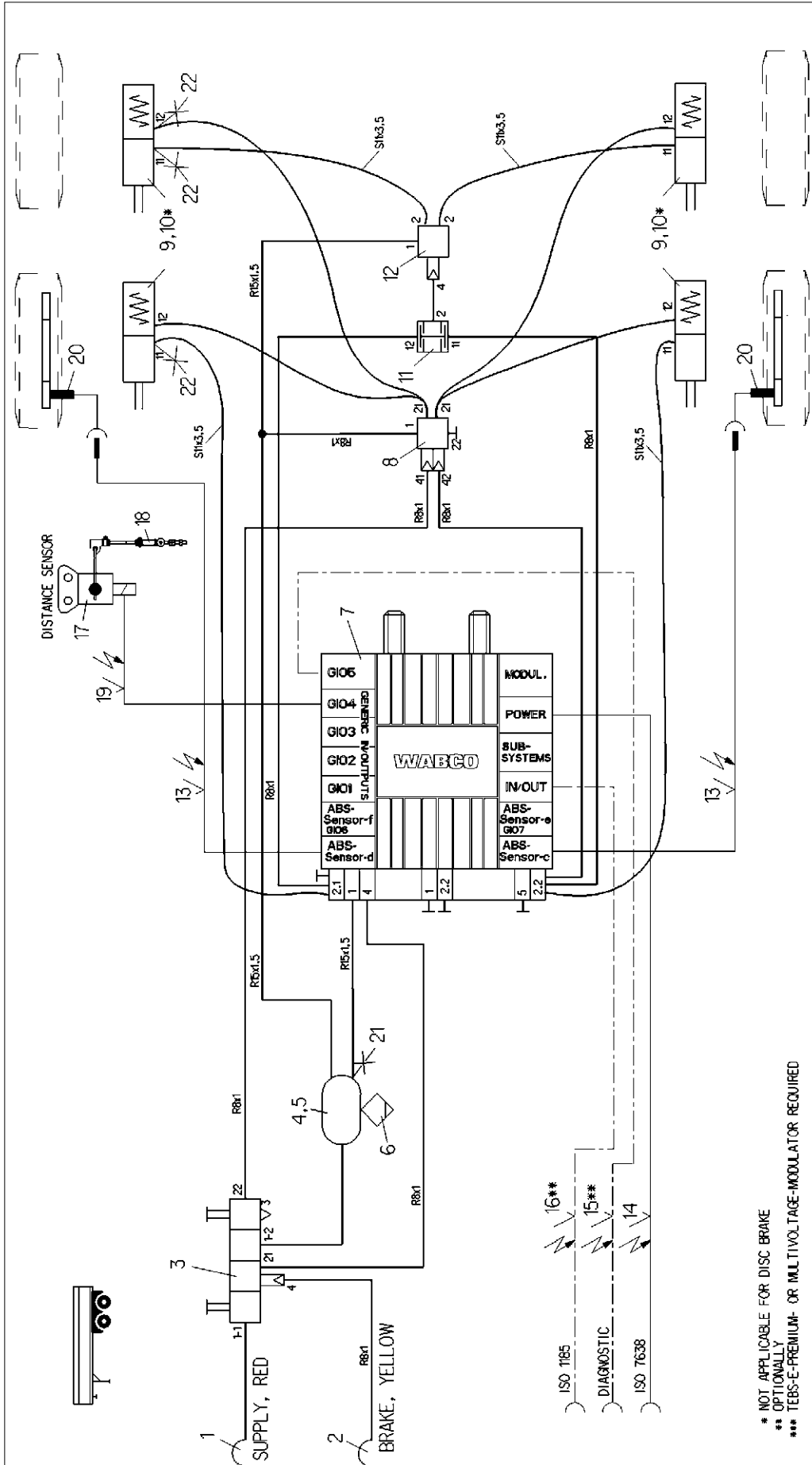

* NOT APPLICABLE FOR DISC BRAKE
 ** OPTIONALLY
 *** TEB5-E-PREMIUM- OR MULTIVOLTAGE-MODULATOR REQUIRED

Pos.	Denomination	Product Identification No.	Pos.	Pos.
1	RELAY VALVE	973 011 000 0	24	
1	DOUBLE CHECK VALVE	434 500 003 0	23	
4	KIT	423 903 532 2	22	3 TEST CONNECTION
4	TRISTOP BRAKE ACTUATOR	925 0	21	1 TEST CONNECTION
1	OVERLOAD-PROTECTION-RV	973 011 201 0	20	2 ABS-SENSOR
1	TRAILER-MODULATOR	480 102 ... 0	19	1 GIO-CABLE DISTANCE SENSOR
1	DRAIN VALVE	934 300 001 0	18	1 LINKAGE
2	HOSE CLAMP	451 999 ... 2	17	1 DISTANCE SENSOR
1	AIR RESERVOIR	930 0	16	1 24N-CABLE
1	PARK-RELEASE-EMERGENCY VALVE (PREV)	971 002 9... 0	15	1 DIAGNOSTIC CABLE
1	COUPLING HEAD W. INT. LINE FILTER	952 201 ... 0	14	1 SUPPLY (POWER) CABLE
1	COUPLING HEAD W. INT. LINE FILTER	952 201 ... 0	13	2 EXTENSION CABLE FOR SENSOR
	Denomination	Product Identification No.		Denomination
A 3	CREO	841 701 278 0	4990	HMR 00496

WABCO

TRAILER - EBS E

FOR 2-AXLES-SEMITRAILER
 2S/2M AND SELECT LOW REGULATION ON AXLE 2
 RSS-FUNCTION (STEEL SUSPENSION)

Date	2014-12-10	Drawn	BURMESTER
Checked	2014-12-10	Checked	CHRONIS
Expert	BURMESTER	Expert	BURMESTER
Appr.	3036	Appr.	3036
Proj. No.	841 701 278 0	Proj. No.	841 701 278 0
Rev. No.	002	Rev. No.	EN
Rev. Date	1/1	Rev. Date	1/1

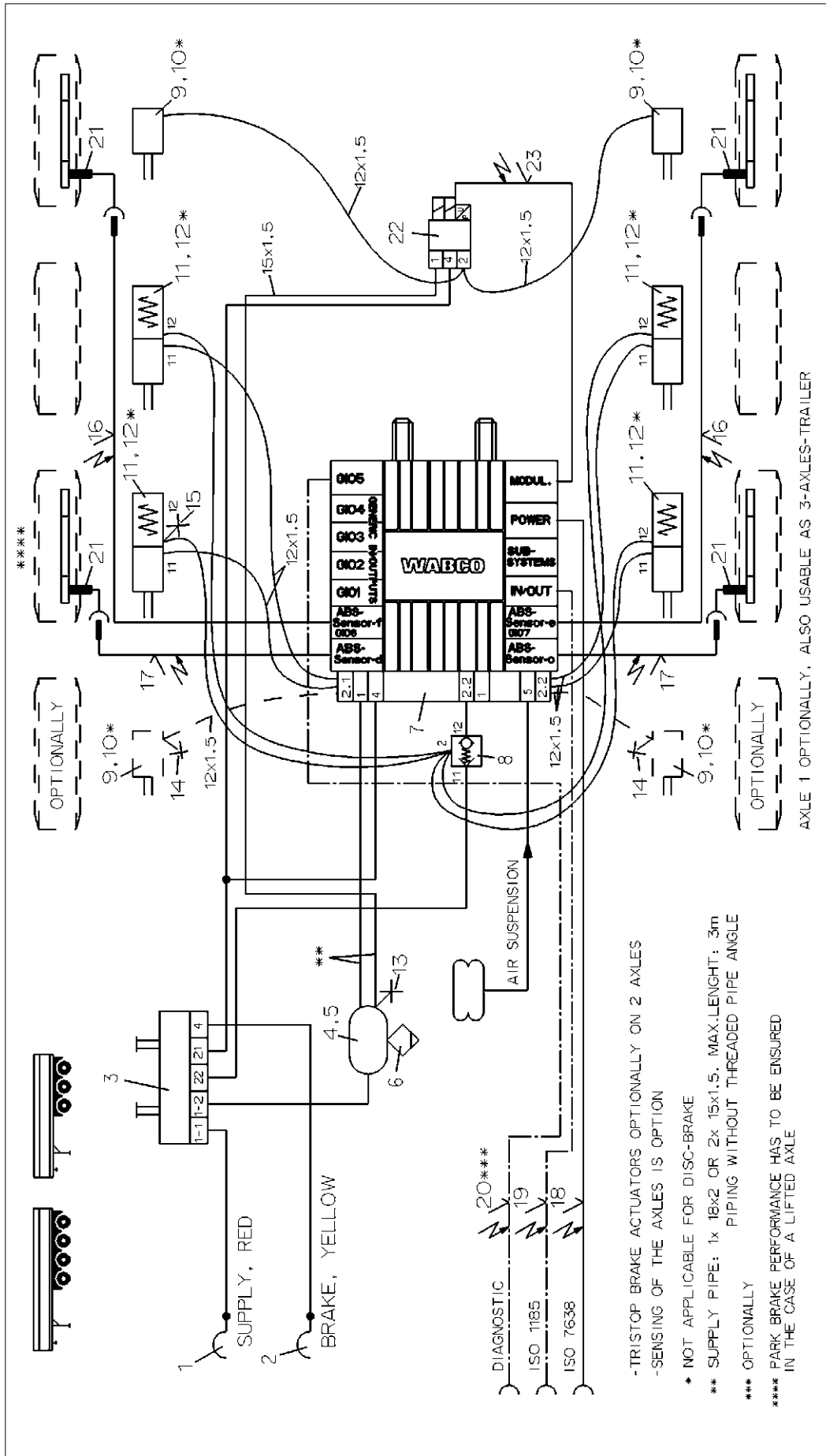

AXLE 1 OPTIONALLY, ALSO USABLE AS 3-AXLES-TRAILER

-TRISTOP BRAKE ACTUATORS OPTIONALLY ON 2 AXLES
-SENSING OF THE AXLES IS OPTION

* NOT APPLICABLE FOR DISC-BRAKE

** SUPPLY PIPE: 1x 18x2 OR 2x 15x1.5. MAX. LENGTH: 3m
PIPING WITHOUT THREADED PIPE ANGLE

*** OPTIONALLY

**** PARK BRAKE PERFORMANCE HAS TO BE ENSURED
IN THE CASE OF A LIFTED AXLE

Pos./Pos.		Denomination		Product Identification No.		Pos./Pos.		Denomination		Product Identification No.			
12	4	*	423 903 532 2	23	1	CABLE TO EBS-RV	449 429 000 0						
11	4	*	925 0	22	1	EBS-RELAY VALVE	480 207 001 0						
10	4	*	423 000 ... 2	21	4	ABS-SENSOR	441 032 8... 0						
9	4		423 10... .. 0	20	1	DIAGNOSTIC CABLE	449 611 000 0						
8	1		434 208 055 0	19	1	24V-CABLE	449 349 000 0						
7	1		480 102 ... 0	18	1	SUPPLY (POWER) CABLE	449 173 000 0						
6	1		934 300 001 0	17	2	EXTENSION CABLE FOR SENSOR	449 723 000 0						
5	2		451 999 ... 2	16	2	EXTENSION CABLE FOR SENSOR	449 723 000 0						
4	1		950 0	15	1	TEST CONNECTION	463 703 035 0						
3	1		971 002 9... 0	14	2	TEST CONNECTION	463 703 120 0						
2	1		982 201 001 0	13	1	TEST CONNECTION	463 703 ... 0						
1	1		982 201 002 0										
											TRISTOP BRAKE ACTUATOR		
											BRAKE CHAMBER		
											TWO-WAY-VALVE		
											TRAILER-MODULATOR		
											DRAIN VALVE		
											HOSE CLAMP		
											AIR RESERVOIR		
											PARK-RELEASE-EMERG.-VALVE (PREV)		
											COUPLING HEAD W. INT. LINE FILTER		
											COUPLING HEAD W. INT. LINE FILTER		



TRAILER - EBS E
FOR 3- AND 4-AXLES-SEMI TRAILER
4S/3M

Date:		06-12-04		Checked:		06-12-04		Status:		GROSSK.	
Title:		TRAILER - EBS E		Author:		BURMESTER		Part No.:		841 701 050 0	
Project No.:		123543		Version:		B		Rev. No.:		4990	
Scale:		A 3		Doc. System:		46		Proj. No.:		123543	
Material No.:		841 701 050 0		Ex. No.:		002		Rev. Date:		EN 1/1	
Product Identification No.:		841 701 050 0		Author:		Burmeister		Appr.:		Burmeister	
Denomination:		TRAILER - EBS E		Scale:		A 3		Proj. No.:		123543	

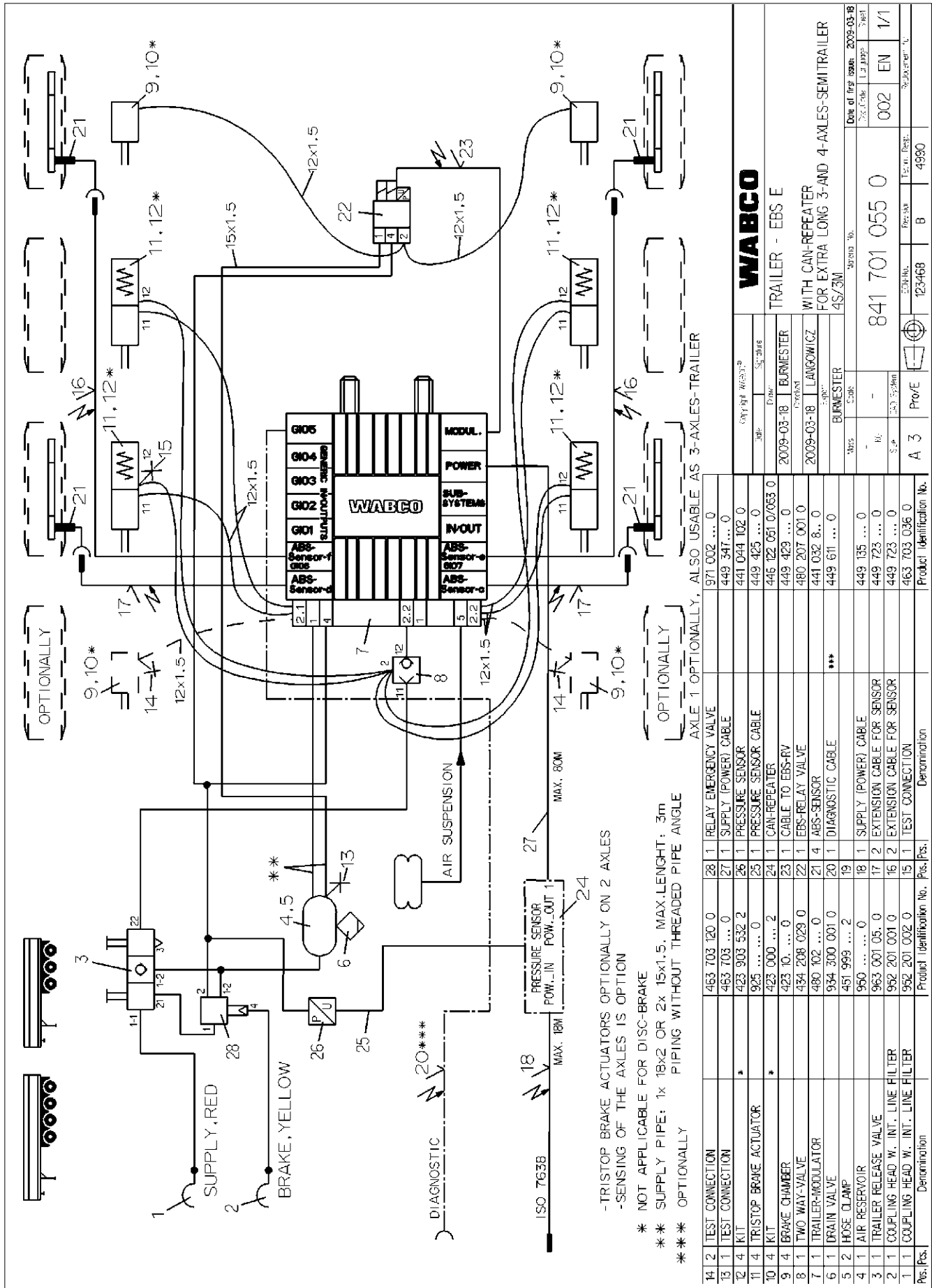

AXLE 1 OPTIONALLY, ALSO USABLE AS 3-AXLES-TRAILER

14	2	TEST CONNECTION	463 703 120 0	28	1	RELAY EMERGENCY VALVE	971 002 ... 0
13	1	TEST CONNECTION	463 703 ... 0	27	1	SUPPLY (POWER) CABLE	449 347 ... 0
12	4	KIT	423 903 532 2	26	1	PRESSURE SENSOR	441 044 102 0
11	4	TRISTOP BRAKE ACTUATOR	925 ... 0	25	1	PRESSURE SENSOR CABLE	449 425 ... 0
10	4	KIT	423 000 ... 2	24	1	CAN-REPEATER	446 122 061 0/063 0
9	4	BRAKE CHAMBER	423 10 ... 0	23	1	CABLE TO EBS-RV	449 429 ... 0
8	1	TWO-WAY-VALVE	434 208 029 0	22	1	EBS-RELAY VALVE	480 207 001 0
7	1	TRAILER-MODULATOR	480 102 ... 0	21	4	ABS-SENSOR	441 032 8 ... 0
6	1	DRAIN VALVE	934 300 001 0	20	1	DIAGNOSTIC CABLE	449 611 ... 0
5	2	HOSE CLAMP	451 999 ... 2	19			
4	1	AIR RESERVOIR	950 ... 0	18	1	SUPPLY (POWER) CABLE	449 135 ... 0
3	1	TRAILER RELEASE VALVE	963 001 05 ... 0	17	2	EXTENSION CABLE FOR SENSOR	449 723 ... 0
2	1	COUPLING HEAD W. INT. LINE FILTER	952 201 001 0	16	2	EXTENSION CABLE FOR SENSOR	449 723 ... 0
1	1	COUPLING HEAD W. INT. LINE FILTER	952 201 002 0	15	1	TEST CONNECTION	463 703 036 0
Pos./Pos.		Denomination	Product Identification No.	Pos./Pos.		Denomination	Product Identification No.

WABCO

TRAILER - EBS E WITH CAN-REPEATER FOR EXTRA LONG 3- AND 4-AXLES-SEMITRAILER 4S/3M

Version No.	841 701 055 0
Part No.	123468
Rev. in Resp.	B
4990	

Doc. Code	1.1.1.1.1.1
Page	3/3
Date of first issue	2009-03-18

* NOT APPLICABLE FOR DISC-BRAKE

** SUPPLY PIPE: 1x 18x2 OR 2x 15x1.5, MAX.LENGTH: 3m PIPING WITHOUT THREADED PIPE ANGLE

*** OPTIONALLY

- TRISTOP BRAKE ACTUATORS OPTIONALLY ON 2 AXLES

- SENSING OF THE AXLES IS OPTION

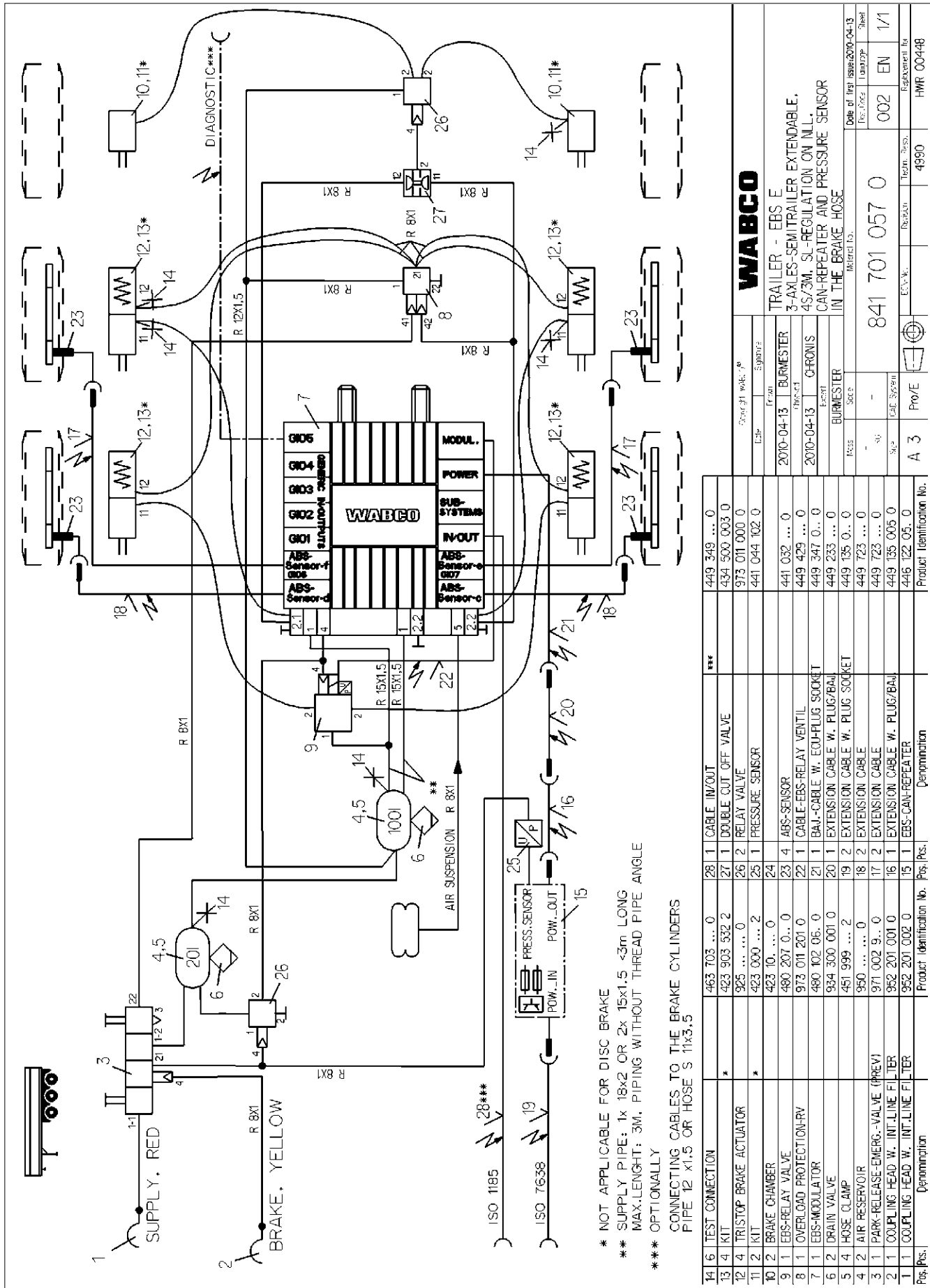

* NOT APPLICABLE FOR DISC BRAKE
 ** SUPPLY PIPE: 1x 18x2 OR 2x 15x1.5 <3m LONG
 MAX. LENGTH: 3M, PIPING WITHOUT THREAD PIPE ANGLE
 *** OPTIONAL

CONNECTING CABLES TO THE BRAKE CYLINDERS
 PIPE 12 x1.5 OR HOSE S 11x3.5

Pos./Pcs.	Denomination	Pos./Pcs.	Denomination
14 6	TEST CONNECTION	463 703 ... 0	28 1 CABLE IN/OUT
13 4	KIT	423 903 532 2	27 1 DOUBLE OUT OFF VALVE
12 4	TRISTOP BRAKE ACTUATOR	923 0	26 2 RELAY VALVE
11 2	KIT	423 000 ... 2	25 1 PRESSURE SENSOR
10 2	BRAKE CHAMBER	423 10 ... 0	24
9 1	EBS-RELAY VALVE	480 207 0.. 0	23 4 ABS-SENSOR
8 1	OVERLOAD PROTECTION-RV	973 011 201 0	22 1 CABLE-EBS-RELAY VENTIL
7 1	EBS-MODULATOR	480 102 06. 0	21 1 BAJ-CABLE W. EQUI-PLUG SOCKET
6 2	DRAIN VALVE	934 300 001 0	20 1 EXTENSION CABLE W. PLUG/BAJ
5 4	HOSE CLAMP	451 999 ... 2	19 2 EXTENSION CABLE W. PLUG SOCKET
4 2	AIR RESERVOIR	950 0	18 2 EXTENSION CABLE
3 1	PARK-RELEASE-EMERG.-VALVE (PREV)	971 002 9.. 0	17 2 EXTENSION CABLE
2 1	COUPLING HEAD W. INT.LINE FILTER	932 201 001 0	16 1 EXTENSION CABLE W. PLUG/BAJ
1 1	COUPLING HEAD W. INT.LINE FILTER	932 201 002 0	15 1 EBS-CAN-REPEATER
	Denomination		Denomination
	Product Identification No.		Product Identification No.
	A 3	Pro/E	4990
	4990	4990	4990
	841 701 057 0	841 701 057 0	841 701 057 0
	EN	EN	EN
	002	002	002
	1/1	1/1	1/1

WABCO

TRAILER - EBS E
 3-AXLES-SEMITRAILER EXTENDABLE,
 4S/3M, SL-REGULATION ON M.L.,
 CAN-REPEATER AND PRESSURE SENSOR
 IN THE BRAKE HOSE

Doc. No.	Language	Sheet
841 701 057 0	EN	1/1

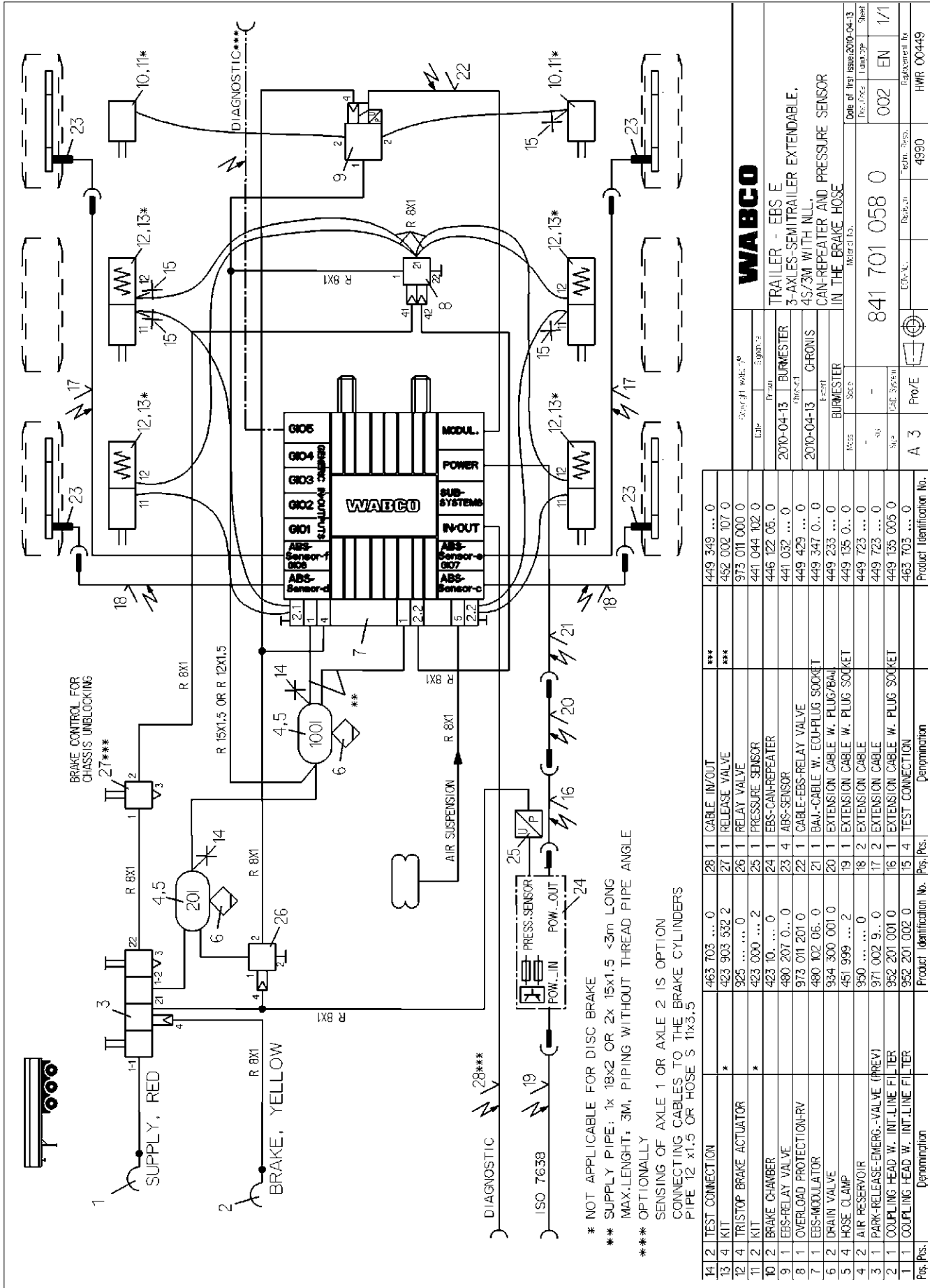

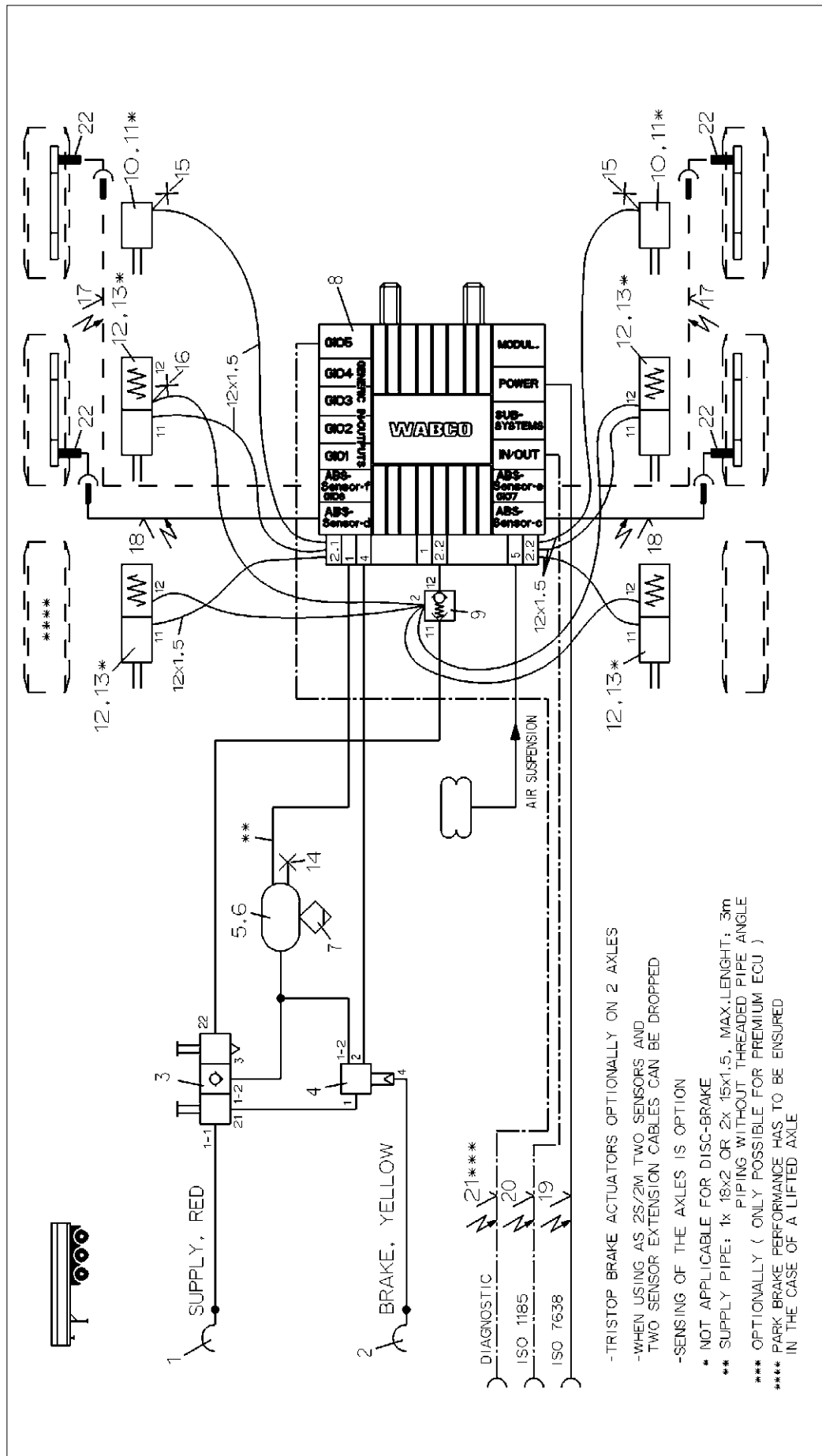

-TRISTOP BRAKE ACTUATORS OPTIONALLY ON 2 AXLES
 -WHEN USING AS 2S/2M TWO SENSORS AND TWO SENSOR EXTENSION CABLES CAN BE DROPPED
 -SENSING OF THE AXLES IS OPTION
 * NOT APPLICABLE FOR DISC-BRAKE
 ** SUPPLY PIPE: 1x 18x2 OR 2x 15x1.5, MAX.LENGTH: 3m PIPING WITHOUT THREADED PIPE ANGLE
 *** OPTIONALLY (ONLY POSSIBLE FOR PREMIUM ECU)
 ***** PARK BRAKE PERFORMANCE HAS TO BE ENSURED IN THE CASE OF A LIFTED AXLE

Part No.	Description	Q'ty	Pos.	Denomination
12	4 TRISTOP BRAKE ACTUATOR	925 ... 0		
11	2 KIT	423 000 ... 2		
10	2 BRAKE CHAMBER	423 10 ... 0	22	4 ABS-SENSOR
9	1 TWO WAY-VALVE	434 208 095 0	21	1 DIAGNOSTIC CABLE
8	1 TRAILER-MODULATOR	480 102 ... 0	20	1 24N-CABLE
7	1 DRAIN VALVE	934 300 001 0	19	1 SUPPLY (POWER) CABLE
6	2 HOSE CLAMP	451 999 ... 0	18	2 EXTENSION CABLE FOR SENSOR
5	1 AIR RESERVOIR	950 ... 0	17	2 EXTENSION CABLE FOR SENSOR
4	1 TRAILER-BRAKE VALVE	971 002 301 0	16	1 TEST CONNECTION
3	1 DOUBLE RELEASE VALVE	963 001 05. 0	15	2 TEST CONNECTION
2	1 COUPLING HEAD W.INT. LINE FILTER	952 201 ... 0	14	1 TEST CONNECTION
1	1 COUPLING HEAD W.INT. LINE FILTER	952 201 ... 0	13	4 KIT

Copyright WABCO®		WABCO	
ITEC	30mm	TRAILER - EBS E	
06-10-11	APITHY	FOR 3-AXLES-SEMI TRAILER	
06-10-11	GROSSK.	4S/2M OR 2S/2M	
BURMESTER		WITH TRAILER-BRAKE VALVE	
Part No. 841 701 100 0			
46	623 Stellen	EN	1/1
A 3	Pro/E	123543 C 4990	

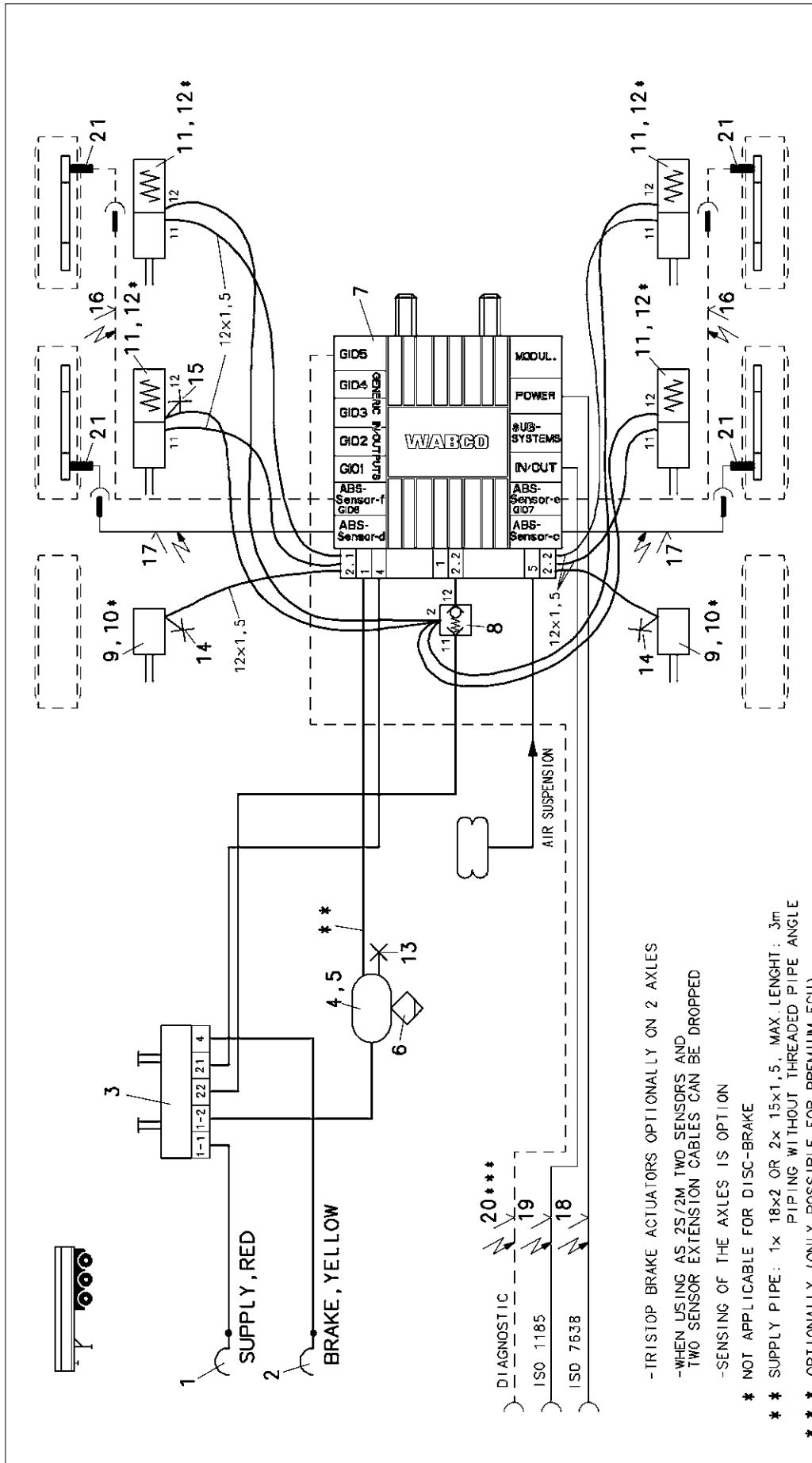

-TRISTOP BRAKE ACTUATORS OPTIONALLY ON 2 AXLES
 -WHEN USING AS 2S/2M TWO SENSORS AND TWO SENSOR EXTENSION CABLES CAN BE DROPPED
 -SENSING OF THE AXLES IS OPTION
 * NOT APPLICABLE FOR DISC-BRAKE
 ** SUPPLY PIPE: 1x 18x2 OR 2x 15x1,5, MAX. LENGTH: 3m PIPING WITHOUT THREADED PIPE ANGLE
 *** OPTIONALLY (ONLY POSSIBLE FOR PREMIUM ECU)

DRAWING NO.		DATE		SIGNATURE		WABCO	
13 1 TEST CONNECTION		463 703 115 0					
12 4 KIT		423 903 532 2		*			
11 4 TRISTOP BRAKE ACT.		925 0					
10 2 KIT		423 000 ... 2		*			
9 2 BRAKE CHAMBER		423 10 0					
8 1 TWO WAY-VALVE		434 208 055 0 21		4 ABS-SENSOR		441 032 8... 0	
7 1 TRAILER-MODULATOR		480 102 0 20		4 DIAGNOSTIC CABLE		449 511 000 0	
6 1 DRAIN VALVE		934 300 001 0 19		1 24N-CABLE		449 349 000 0	
5 2 HOSE CLAMP		451 999 0 18		1 SUPPLY(POWER)-CABLE		449 173 000 0	
4 1 AIR RESERVOIR		950 0 17		2 EXTENSION CABLE		FOR SENSOR	
3 1 PARK-RELEASE-EMERG - VALVE (PREV)		971 002 9... 0 16		2 EXTENSION CABLE		FOR SENSOR	
2 1 COUPLING HEAD W. INT. LINE FILTER		952 201 0 15		1 TEST CONNECTION		449 723 000 0	
-1 1 COUPLING HEAD W. INT. LINE FILTER		952 201 0 14		2 TEST CONNECTION		463 703 035 0	
DENOMINATION		PRODUCT IDENTIFICATION No.		PR. RES.		DENOMINATION	
		463 703 120 0		111301 A		108-10-24	
DCN-NO. (REV)		DATE		CODE FOR FUNCTION		REPLACEMENT FOR	
A 3		111960 B		108-12-21		402 01	
SIZE		171		PRODUCT IDENTIFICATION NO.		CODE FOR DOCUMENT SHEET	
841 701 101 0		171		3124		402 01	
DATE FOR SHAPE		DATE		DATE		DATE	

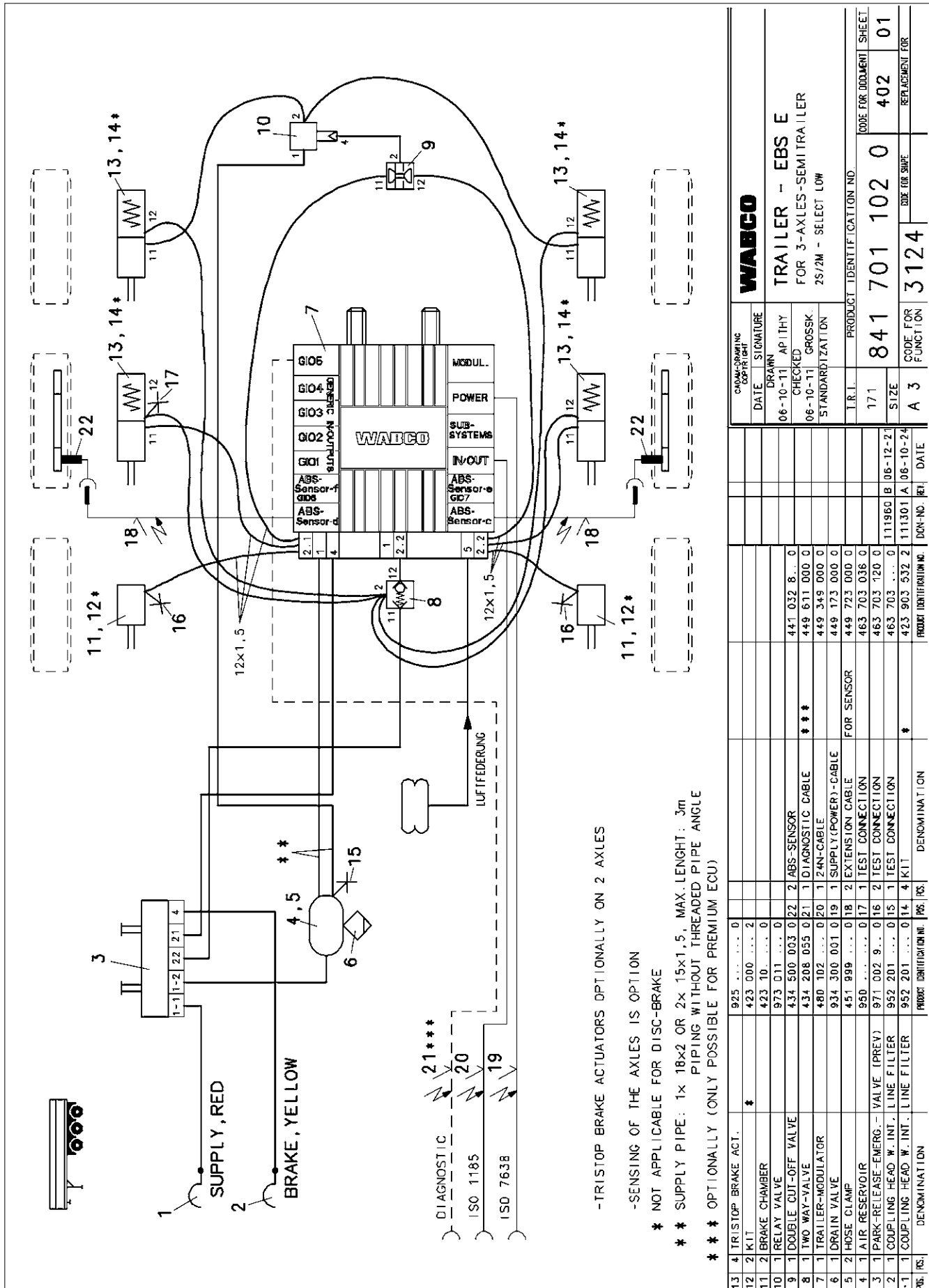

DRAWING CODE		SIGNATURE		WABCO	
DATE	SIGNATURE	DATE	SIGNATURE	TRAILER - EBS E	CODE FOR DOCUMENT SHEET
06-10-11	AP THY	06-10-11	GROSSK.	FOR 3-AXLES-SEMITRAILER	402 01
STANDARDIZATION		PRODUCT IDENTIFICATION NO.		REPLACEMENT FOR	
		171		841 701 102 0	
CODE FOR FUNCTION		CODE FOR SHAPE		CODE FOR DOCUMENT SHEET	
A 3	3124	841 701 102 0		402 01	

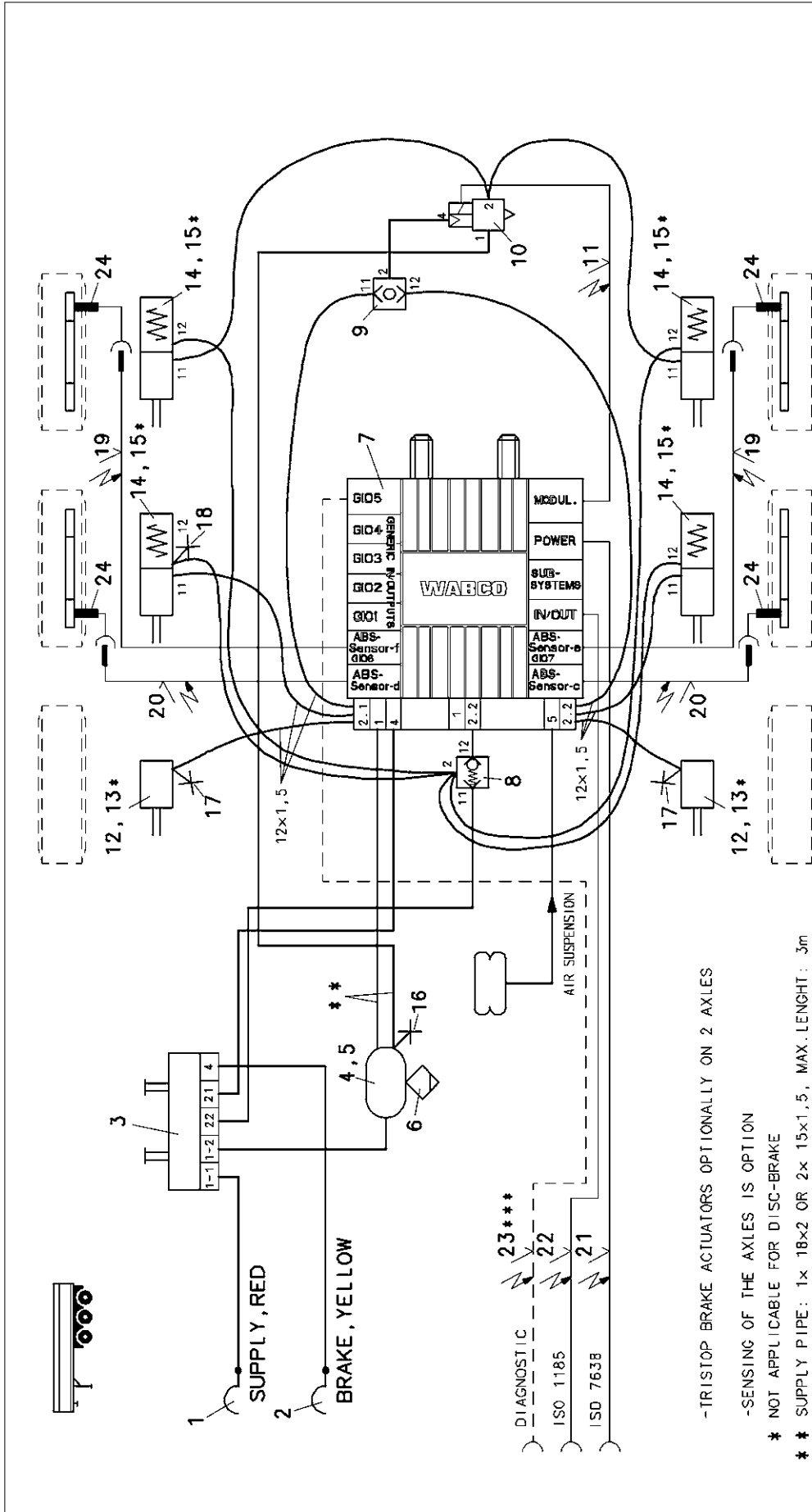

-TRISTOP BRAKE ACTUATORS OPTIONALLY ON 2 AXLES
 -SENSING OF THE AXLES IS OPTION
 * NOT APPLICABLE FOR DISC-BRAKE
 ** SUPPLY PIPE: 1x 18x2 OR 2x 15x1,5, MAX. LENGTH: 3m
 PIPING WITHOUT THREADED PIPE ANGLE
 *** OPTIONALLY (ONLY POSSIBLE FOR PREMIUM ECU)

NO.	QTY.	DESCRIPTION	REF. POS.	DENOMINATION
13	2	KIT		
12	2	BRAKE CHAMBER	423 000 ... 2	
11	1	CABLE TO ABS-RV	449 436 000 0 24	4 ABS-SENSOR
10	1	ABS-RELAY VALVE	472 195 037 0 23	DIAGNOSTIC CABLE
9	1	TWO WAY-VALVE	434 208 0 ... 0 22	1 24N-CABLE
8	1	TWO WAY-VALVE	434 208 055 0 21	1 SUPPLY(POWER)-CABLE
7	1	TRAILER-MODULATOR	480 102 ... 0 20	2 EXTENSION CABLE
6	1	DRAIN VALVE	934 300 001 0 19	2 EXTENSION CABLE
5	2	HOSE CLAMP	451 999 ... 0 18	1 TEST CONNECTION
4	1	AIR RESERVOIR	950 0 17	2 TEST CONNECTION
3	1	PARK-RELEASE-EMERG. VALVE (PREV)	971 002 9 ... 0 16	1 TEST CONNECTION
2	1	COUPLING HEAD W. INT. LINE FILTER	952 201 ... 0 15	4 KIT
-1	1	COUPLING HEAD W. INT. LINE FILTER	952 201 ... 0 14	4 TRISTOP BRAKE ACT.
REF.	POS.	DENOMINATION	POS. POS.	DENOMINATION

DATE	SIGNATURE	DATE	SIGNATURE
06-10-11	AP ITHY	06-10-11	AP ITHY
06-10-11	GROSSK.	06-10-11	GROSSK.

TR.L.R.I.	PRODUCT IDENTIFICATION NO.	CODE FOR DOCUMENT SHEET
171	841 701 103 0	402 01

CODE FOR FUNCTION	CODE FOR SHAPE	REPLACEMENT FOR
A 3	3124	

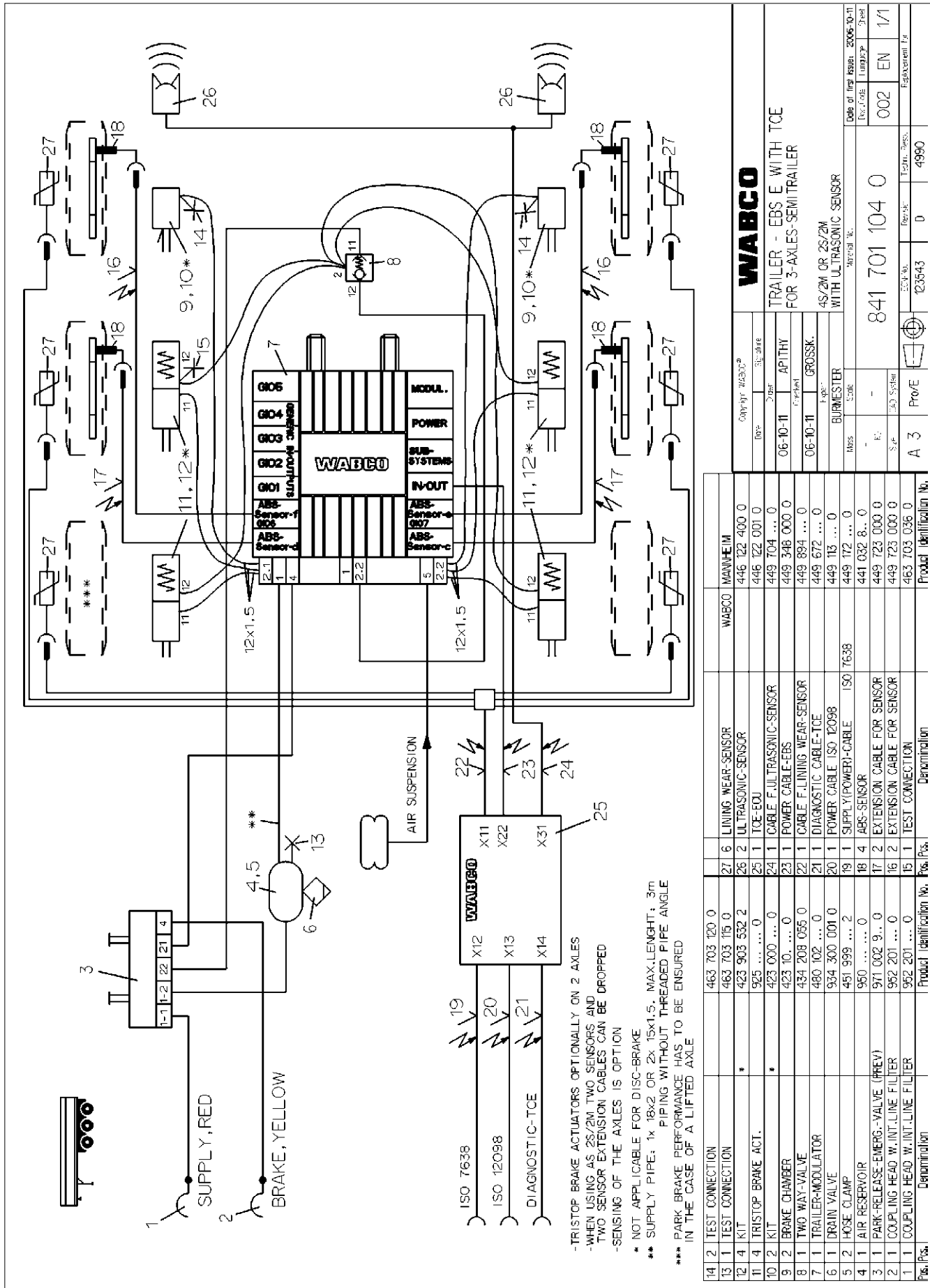

WABCO

TRAILER - EBS E WITH TCE
FOR 3-AXLES-SEMI-TRAILER

4S/2M OR 2S/2M
WITH ULTRASONIC SENSOR

841 701 104 0

Fig. Pos.	Denomination	Product Identification No.	Pos. Pos.	Denomination	Product Identification No.
14	2 TEST CONNECTION	463 703 120 0			
15	1 TEST CONNECTION	463 703 115 0	27	6 LINING WEAR SENSOR	WABCO MAIN/HEIM
16	4 KIT	423 903 532 2	28	2 ULTRASONIC-SENSOR	446 122 400 0
17	4 TRISTOP BRAKE ACT.	925 0	29	1 TCE-EDU	446 122 001 0
18	2 KIT	423 000 ... 0	30	1 CABLE F. ULTRASONIC-SENSOR	449 704 ... 0
19	2 BRAKE CHAMBER	423 10 ... 0	31	1 POWER CABLE-EBS	449 348 000 0
20	1 TWO WAY-VALVE	434 208 095 0	32	1 CABLE F. LINING WEAR-SENSOR	449 894 ... 0
21	1 TRAILER-MODULATOR	480 102 ... 0	33	1 DIAGNOSTIC CABLE-TCE	449 672 ... 0
22	1 DRAIN VALVE	934 300 001 0	34	1 POWER CABLE ISO 12098	449 113 ... 0
23	2 HOSE CLAMP	451 999 ... 2	35	1 SUPPLY(POWER)-CABLE	ISO 7638
24	1 AIR RESERVOIR	950 0	36	4 ABS-SENSOR	441 032 8... 0
25	3 PARK-RELEASE-EMERG.-VALVE (PREV)	971 002 9... 0	37	2 EXTENSION CABLE FOR SENSOR	449 723 000 0
26	1 COUPLING HEAD W. INT. LINE FILTER	952 201 ... 0	38	2 EXTENSION CABLE FOR SENSOR	449 723 000 0
27	1 COUPLING HEAD W. INT. LINE FILTER	952 201 ... 0	39	1 TEST CONNECTION	463 703 036 0
Fig. Pos.	Denomination	Product Identification No.	Pos. Pos.	Denomination	Product Identification No.

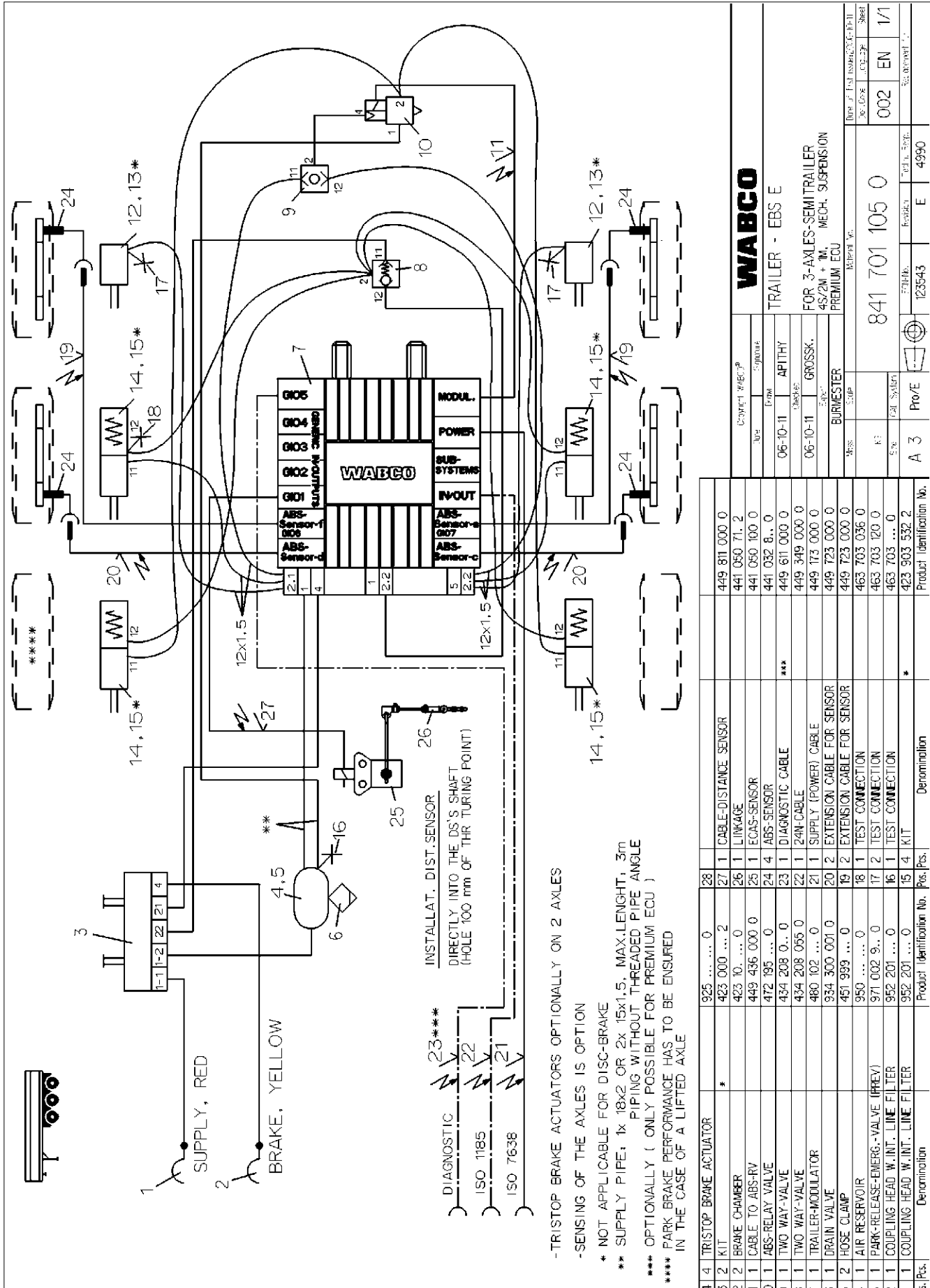

-TRISTOP BRAKE ACTUATORS OPTIONALLY ON 2 AXLES
 -SENSING OF THE AXLES IS OPTION
 * NOT APPLICABLE FOR DISC-BRAKE
 ** SUPPLY PIPE, 1x 18x2 OR 2x 15x1,5, MAX.LENGTH, 3m
 *** OPTIONALLY (ONLY POSSIBLE FOR PREMIUM ECU)
 ***** PARK BRAKE PERFORMANCE HAS TO BE ENSURED
 IN THE CASE OF A LIFTED AXLE

Part No.		Qty.	Description	Unit	Product Identification No.	Pos.	Pcs.
4	TRISTOP BRAKE ACTUATOR	925 ... 0		28			
5	KIT	423 000 ... 2	1 CABLE-DISTANCE SENSOR	449 811 000 0			
2	BRAKE CHAMBER	423 10 ... 0	1 LINKAGE	441 060 71. 2			
2	CABLE TO ABS-DRV	449 436 000 0	1 ECAS-SENSOR	441 060 100 0			
0	ABS-RELAY VALVE	412 195 ... 0	4 ABS-SENSOR	441 032 8.. 0			
1	TWO WAY VALVE	434 208 0.. 0	1 DIAGNOSTIC CABLE	449 611 000 0			
1	TRAILER-MODULATOR	480 102 ... 0	1 24N-CABLE	449 349 000 0			
1	DRAIN VALVE	934 300 001 0	1 SUPPLY (POWER) CABLE	449 173 000 0			
5	HOSE CLAMP	451 999 ... 0	2 EXTENSION CABLE FOR SENSOR	449 723 000 0			
1	AIR RESERVOIR	950 ... 0	1 TEST CONNECTION	463 703 036 0			
3	PARK-RELEASE-EMERG.-VALVE (PREV)	971 002 9.. 0	17 2 TEST CONNECTION	463 703 120 0			
1	COUPLING HEAD W. INT. LINE FILTER	952 201 ... 0	16 1 TEST CONNECTION	463 703 ... 0			
1	COUPLING HEAD W. INT. LINE FILTER	952 201 ... 0	15 4 KIT	423 903 532 2			
1	Denomination		Product Identification No.				

WABCO
 TRAILER - EBS E
 FOR 3-AXLES-SEMITRAILER
 4S/2M + IM. MECH. SUSPENSION
 PREMIUM ECU

Retired No. 841 701 105 0

Part No. 123543

Part No. 4990

Rev. 002 EN 1/1

841 701 106 0

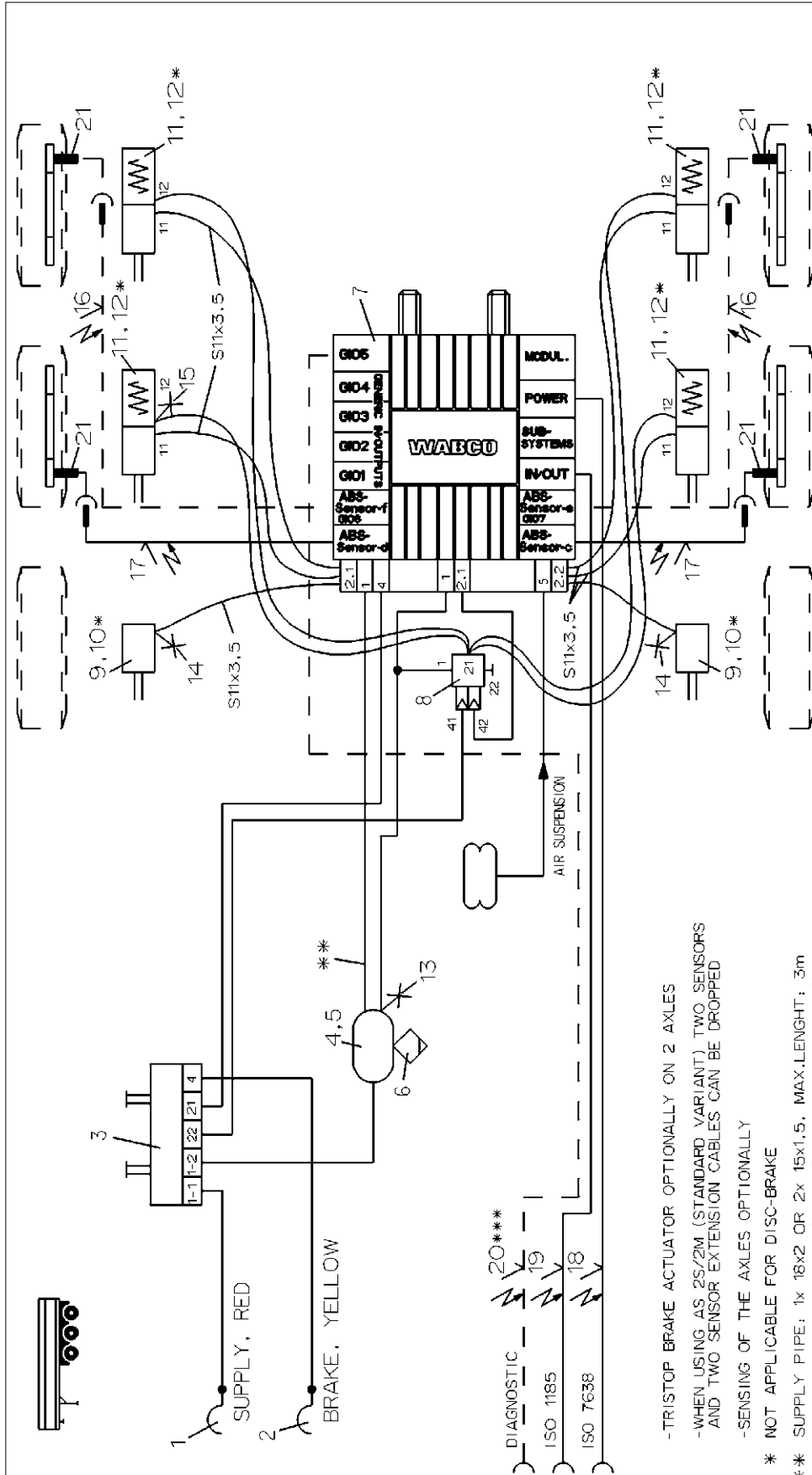

- TRISTOP BRAKE ACTUATOR OPTIONALLY ON 2 AXLES
- WHEN USING AS 2S/2M (STANDARD VARIANT) TWO SENSORS AND TWO SENSOR EXTENSION CABLES CAN BE DROPPED
- SENSING OF THE AXLES OPTIONALLY
- * NOT APPLICABLE FOR DISC-BRAKE
- ** SUPPLY PIPE: 1x 18x2 OR 2x 15x1.5, MAX. LENGTH: 3m PIPING WITHOUT THREAD PIPE ANGLE
- *** OPTIONALLY (ONLY WITH PREMIUM VARIANT POSSIBLE)

13	1	TEST CONNECTION	463 703 115 0			
12	4	KIT	423 903 532 2			
11	4	TRISTOP BRAKE ACTUATOR	923 0			
10	2	KIT	423 000 ... 2			
9	2	BRAKE CHAMBER	423 10 ... 0			
8	1	OVERLOAD-PROTECTION-RV	973 011 201 0	21	4	ABS-SENSOR
7	1	TRAILER-MODULATOR	480 102 ... 0	20	1	DIAGNOSTIC CABLE
6	1	DRAIN VALVE	934 300 001 0	19	1	24N-CABLE
5	2	HOSE CLAMP	451 999 ... 0	18	1	SUPPLY (POWER) CABLE
4	1	AIR RESERVOIR	950 0	17	2	EXTENSION CABLE FOR SENSOR
3	1	PARK-RELEASE-EMERGENCY VALVE (PREV)	971 002 9.. 0	16	2	EXTENSION CABLE FOR SENSOR
2	1	COUPLING HEAD W. INT.-LINE FILTER	982 201 ... 0	15	1	TEST CONNECTION
1	1	COUPLING HEAD W. INT.-LINE FILTER	982 201 ... 0	14	2	TEST CONNECTION
Res./Pcs.		Denomination	Product Identification No.	Pcs./Pcs.	Denomination	

WABCO

TRAILER - EBS E
FOR 3-AXLES-SEMI TRAILER
4S/2M OR 2S/2M

Part No. **841 701 106 0**
E307 No. **4990**

Rev. No. **EN** / **1/1**

Date of final issue: 2008-10-06

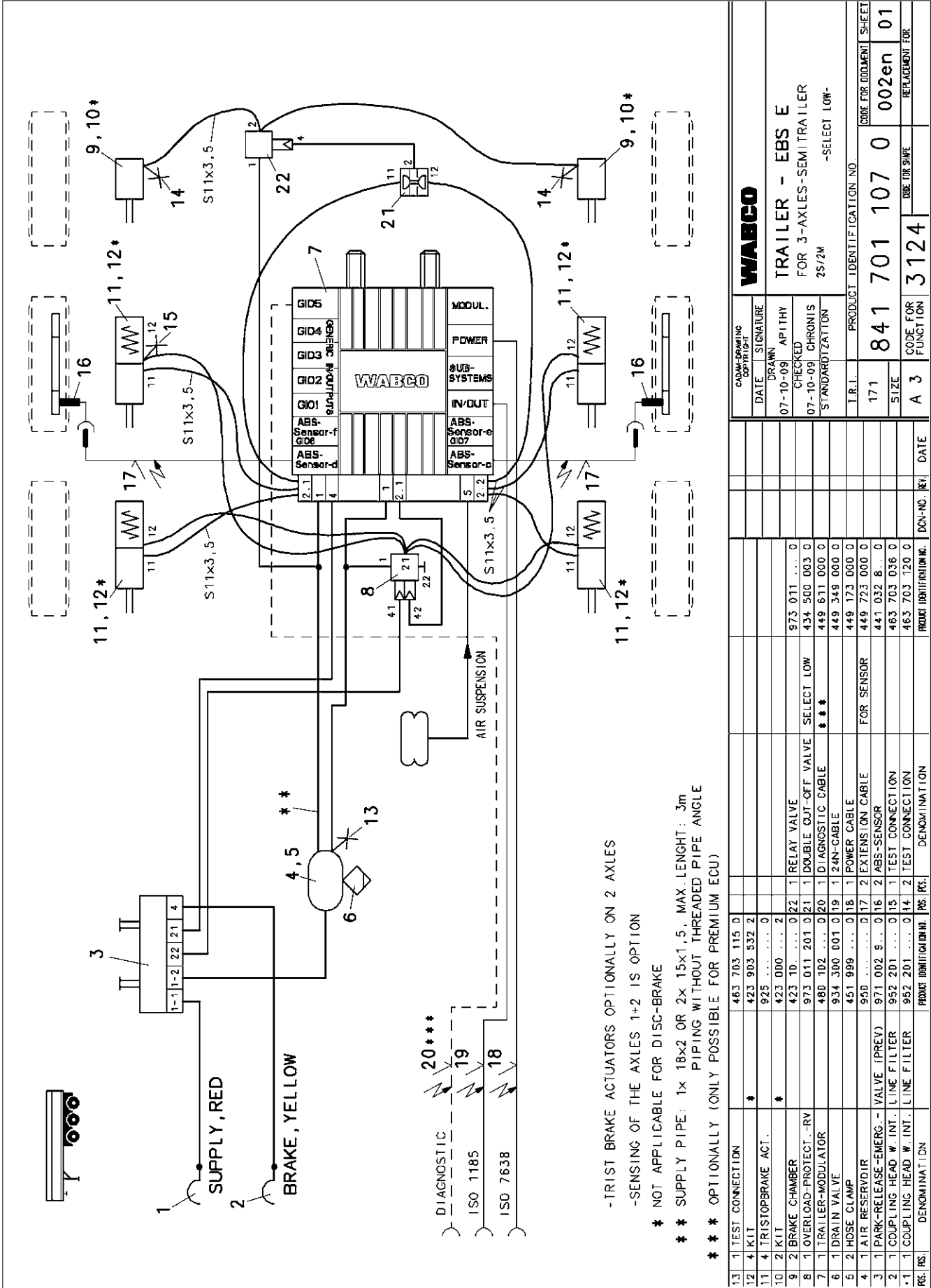

-TRIST BRAKE ACTUATORS OPTIONALY ON 2 AXLES
 -SENSING OF THE AXLES 1+2 IS OPTION
 * NOT APPLICABLE FOR DISC-BRAKE
 ** SUPPLY PIPE: 1x 18x2 OR 2x 15x1,5, MAX. LENGTH: 3m
 PIPING WITHOUT THREADED PIPE ANGLE
 *** OPTIONALLY (ONLY POSSIBLE FOR PREMIUM ECU)

CAD/DRWING DATE		SIGNATURE		WABCO	
07-10-09	AP	PHY	TRAILER - EBS E	FOR 3-AXLES-SEMI TRAILER	
07-10-09	CHRONIS	STANDARDIZATION	2S/2M	-SELECT LOW-	
I.R.I. PRODUCT IDENTIFICATION NO.				CODE FOR DDL/MENT	SHEET
171	841	701	107	0	002en 01
SIZE				CODE FOR FUNCTION	REPLACEMENT FOR
A 3				3124	
PRODUCT IDENTIFICATION NO.		DENOMINATION		PCS.	DATE
463 703 115 0					
423 903 532 2					
925 0					
423 000 2					
423 10 0					
423 10 0			22	1	RELAY VALVE
973 011 ... 0			21	1	DOUBLE CUT-OFF VALVE
434 500 003 0			20	1	DIAGNOSTIC CABLE
449 611 000 0			19	1	2-IN-CABLE
449 349 000 0			18	1	POWER CABLE
449 173 000 0			17	2	EXTENSION CABLE
449 723 000 0			16	2	ABS-SENSOR
441 032 8 ... 0			15	1	TEST CONNECTION
463 703 036 0			14	2	TEST CONNECTION
463 703 120 0			13	1	DIAGNOSTIC

841 701 108 0

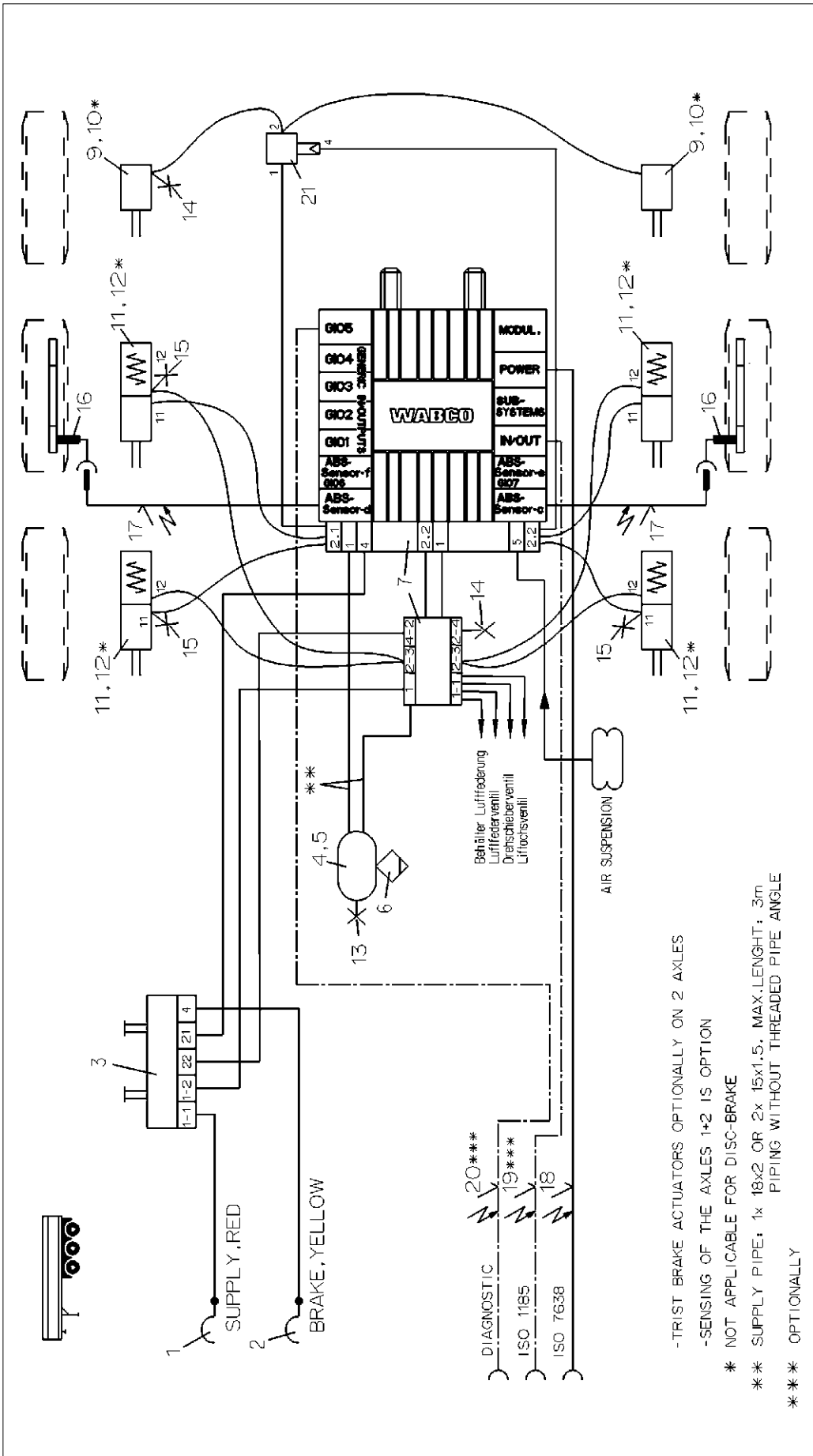

- 12 4 KIT
- 11 4 TRISTOP BRAKE ACTUATOR
- 10 2 KIT
- 9 2 BRAKE CHAMBER
- 8 1 TRAILER-MODULATOR
- 7 1 HOSE CLAMP
- 6 1 PARK-RELEASE-EMERG.-VALVE (PREV)
- 5 2 COUPLING HEAD W.INT.LINE FILTER
- 4 1 COUPLING HEAD W.INT.LINE FILTER

-TRISTOP BRAKE ACTUATORS OPTIONALLY ON 2 AXLES
 -SENSING OF THE AXLES 1+2 IS OPTION
 * NOT APPLICABLE FOR DISC-BRAKE
 ** SUPPLY PIPE: 1x 18x2 OR 2x 15x1.5. MAX.LENTH: 3m
 PIPING WITHOUT THREADED PIPE ANGLE
 *** OPTIONALLY

Copyright Wabco, ®	
Year	Signal
2008-02-20	BURMESTER
2008-02-20	CHRONIS
BURMESTER	
Modul-Nr.	841 701 108 0
Part No.	EN
Revisions-Nr.	1/1
Part No.	002
Revisions-Nr.	EN
Part No.	4990

WABCO
 TRAILER - EBS E
 FOR 3-AXLES-SEMI-TRAILER
 2S/2M
 -SELECT LOW-

Date of first issue: 2008-02-20
 Date of issue: 2010-02-24

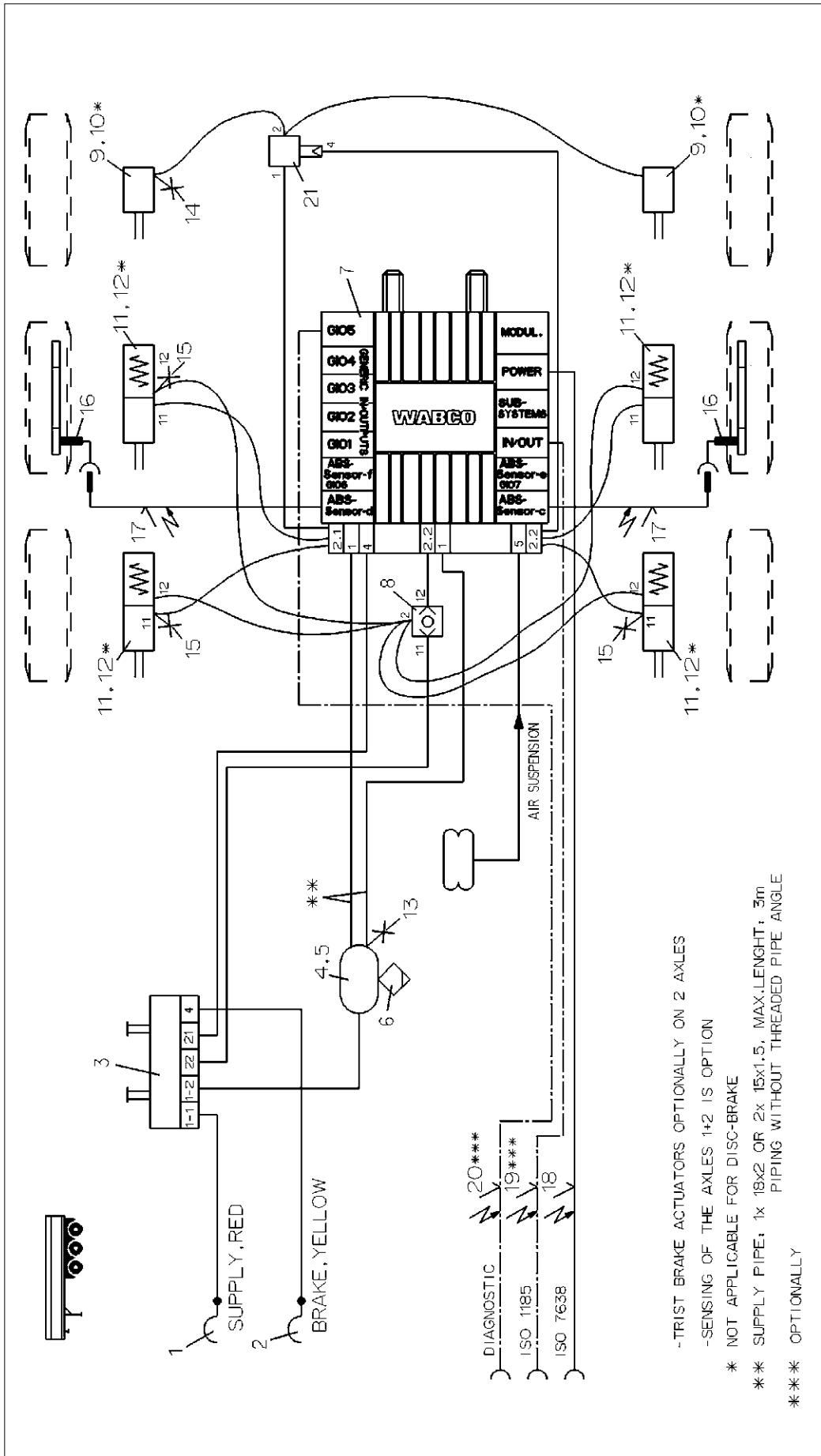

12 4 KIT		* 423 903 532 2								WABCO TRAILER - EBS E FOR 3-AXLES-SEMI TRAILER 2S/2M -SELECT LOW-		Date of first issue: 2008-02-20	
11	4 TRISTOP BRAKE ACTUATOR		925 0									Exc. Code	1/1
10	2 KIT		423 000 ... 2									Library	002
9	2 BRAKE CHAMBER		423 10 ... 0	21	1	RELAY VALVE	973 011 ... 0						Replacement for
8	1 DOUBLE CHECK VALVE		434 208 055 0	20	1	DIAGNOSTIC CABLE	449 611 ... 0						
7	1 TRAILER-MODULATOR		480 102 ... 0	19	1	24N-CABLE	449 349 ... 0						
6	1 DRAIN VALVE		934 300 001 0	18	1	POWER CABLE	449 173 ... 0						
5	2 HOSE CLAMP		451 999 ... 0	17	2	EXTENSION CABLE FOR SENSOR	449 723 ... 0						
4	1 AIR RESERVOIR		950 0	16	2	ABS-SENSOR	441 032 8 ... 0						
3	1 PARK-RELEASE-EMERG.-VALVE (PREV)		971 002 9 ... 0	15	3	TEST CONNECTION	463 703 036 0						
2	1 COUPLING HEAD W. INT. LINE FILTER		952 201 ... 0	14	1	TEST CONNECTION	463 703 120 0						
1	1 COUPLING HEAD W. INT. LINE FILTER		952 201 ... 0	13	1	TEST CONNECTION	463 703 115 0						
Pos./Pcs.	Denomination	Product Identification No.	Pos./Pcs.	Denomination									

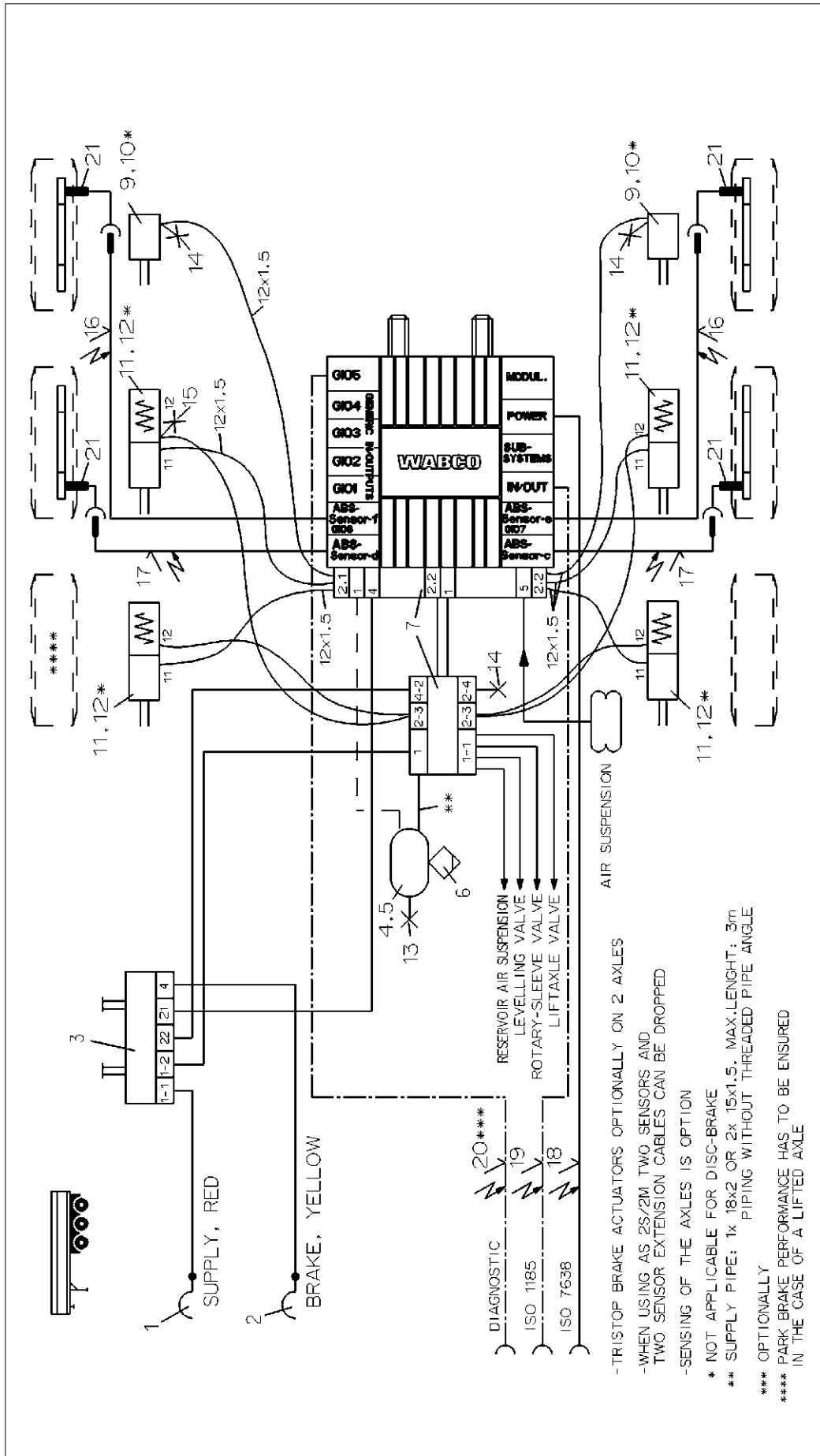

Pos./Pcs.	Denomination	Product Identification No.	Pcs./Pos.	Denomination	Product Identification No.
12 4	KIT	423 903 532 2			
11 4	TRISTOP BRAKE ACTUATOR	925 0			
10 2	KIT	423 000 ... 2			
9 2	BRAKE CHAMBER	423 10. ... 0	21 4	ABS-SENSOR	441 032 8.. 0
8			20 1	DIAGNOSTIC CABLE	449 611 000 0
7 1	TRAIL.-MODULATOR W.EXTENSION MODUL	480 102 ... 0	19 1	24N-CABLE	449 349 000 0
6 1	DRAIN VALVE	934 300 001 0	18 1	SUPPLY (POWER) CABLE	449 173 000 0
5 2	HOSE CLAMP	451 999 ... 2	17 2	EXTENSION CABLE FOR SENSOR	449 723 000 0
4 1	AIR RESERVOIR	950 0	16 2	EXTENSION CABLE FOR SENSOR	449 723 000 0
3 1	PARK-RELEASE-EMERG.-VALVE (PREV)	971 002 9.. 0	15 1	TEST CONNECTION	463 703 036 0
2 1	COUPLING HEAD W. INT. LINE FILTER	952 201 001 0	14 3	TEST CONNECTION	463 703 120 0
1 1	COUPLING HEAD W. INT. LINE FILTER	952 201 002 0	13 1	TEST CONNECTION	463 703 115 0

Copyright WABCO®		WABCO	
Rev.	Signat./s	TRAILER - EBS E	
06-12-04	APITHY	FOR 3-AXLES-SEMITRAILER	
06-12-04	GROSSK.	4S/2M OR 2S/2M	
Date of Issue: 06-12-04		- WITH EXTENSION MODUL -	
Part No.	Part Name	841 701 110 0	
002	EN	1/1	
Revision		123543	
Part No.		4990	

-TRISTOP BRAKE ACTUATORS OPTIONALLY ON 2 AXLES
 -WHEN USING AS 2S/2M TWO SENSORS AND TWO SENSOR EXTENSION CABLES CAN BE DROPPED
 -SENSING OF THE AXLES IS OPTION
 * NOT APPLICABLE FOR DISC-BRAKE
 ** SUPPLY PIPE: 1x 18x2 OR 2x 15x1.5. MAX.LENGTH: 3m
 PIPING WITHOUT THREADED PIPE ANGLE
 *** OPTIONALLY
 ***** PARK BRAKE PERFORMANCE HAS TO BE ENSURED IN THE CASE OF A LIFTED AXLE

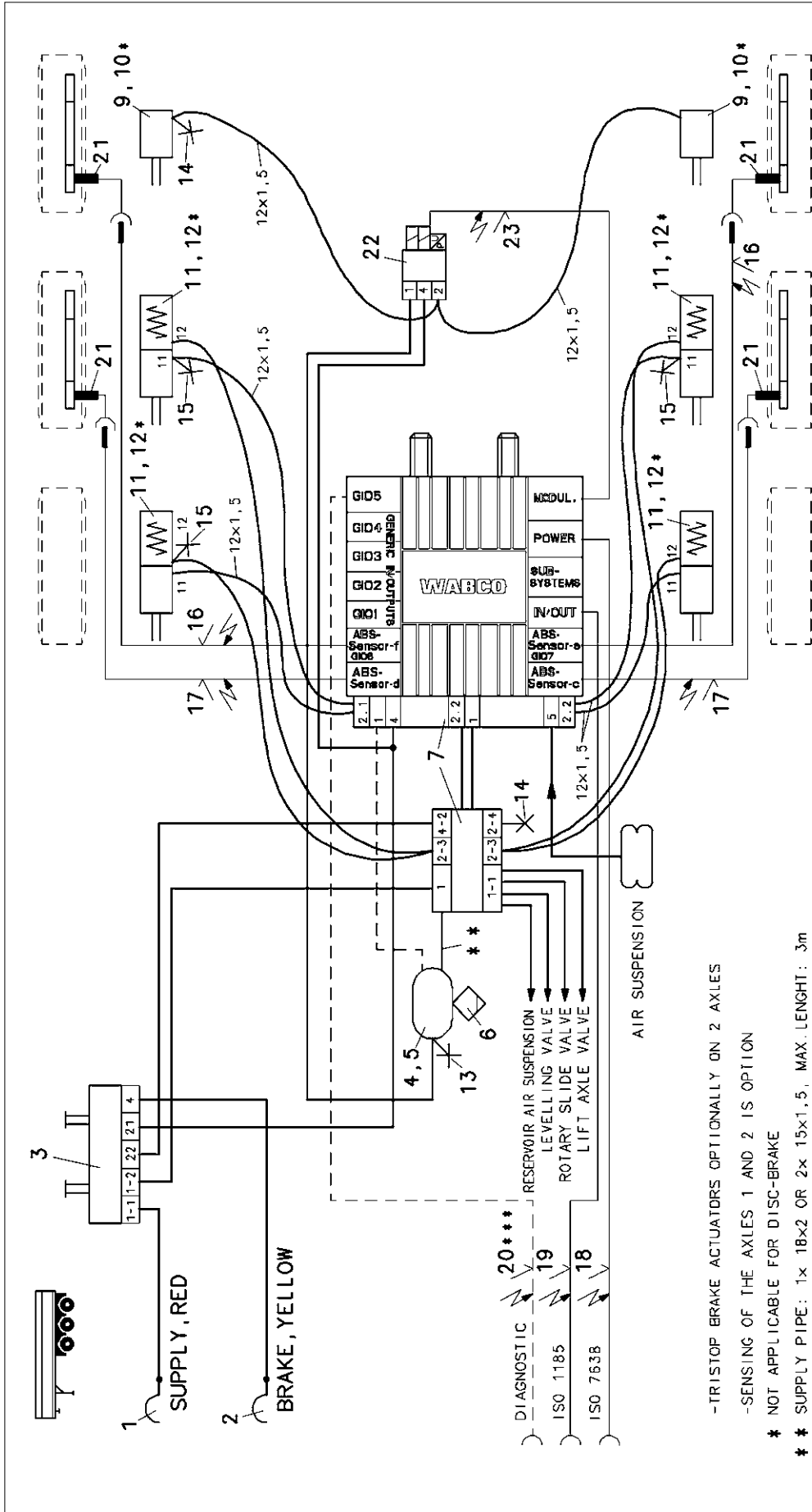

-TRISTOP BRAKE ACTUATORS OPTIONAL ON 2 AXLES
 -SENSING OF THE AXLES 1 AND 2 IS OPTION

* NOT APPLICABLE FOR DISC-BRAKE

** SUPPLY PIPE: 1x 18x2 OR 2x 15x1,5, MAX. LENGTH: 3m
 PIPING WITHOUT THREADED PIPE ANGLE

*** OPTIONAL

NO.	DESCRIPTION	QTY.	REF.	DESIGNATION	PROT. IDENTIFICATION	PROT. IDENTIFICATION	DCN-NO.	REV.	DATE
13	1 TEST CONNECTION	463 703	...	0					
12	4 KIT	423 903	532	2					
11	4 TRISTOP BRAKE ACT.	925	0				
10	2 KIT	423 000	...	2	23	1 CABLE TO EBS-RV	449 429	000	0
9	2 BRAKE CHAMBER	423 10	...	0	22	1 EBS-RELAY VALVE	480 207	001	0
8	21	4 ABS-SENSOR	441 032	8...	0
7	1 TRAIL-MODULATOR W. EXTENSION MOD.	480 102	...	0	20	1 DIAGNOSTIC CABLE	449 611	000	0
6	1 DRAIN VALVE	934 300	001	0	19	1 24N-CABLE	449 349	000	0
5	2 HOSE CLAMP	451 999	...	2	18	1 SUPPLY(POWER)-CABLE	449 173	000	0
4	1 AIR RESERVOIR	950	17	2 EXTENSION CABLE FOR SENSOR	449 723	000	0
3	1 PARK-RELEASE-EMERG. VALVE (PREV)	971 002	9...	0	16	2 EXTENSION CABLE FOR SENSOR	449 723	000	0
2	1 COUPLING HEAD W. INT. LINE FILTER	952 201	001	0	15	3 TEST CONNECTION	463 703	036	0
1	1 COUPLING HEAD W. INT. LINE FILTER	952 201	002	0	14	2 TEST CONNECTION	463 703	120	0

CADD-DRAWING		DATE		SIGNATURE	
DRAWN		07-05-11		AP ITHY	
CHECKED		07-05-11		CHRONIS	
STANDARDIZATION					

WABCO
TRAILER - EBS E
 FOR 3-AXLES-SEMI TRAILER
 4S/3M
 - WITH EXTENSION MODUL-

T.R.L.	PRODUCT IDENTIFICATION NO.	CODE FOR DIMENSIONAL SHEET
171	841 701 111 0	402 01

CODE FOR FUNCTION	CODE FOR SHAPE	REPLACEMENT FOR
A 3	3124	

841 701 112 0

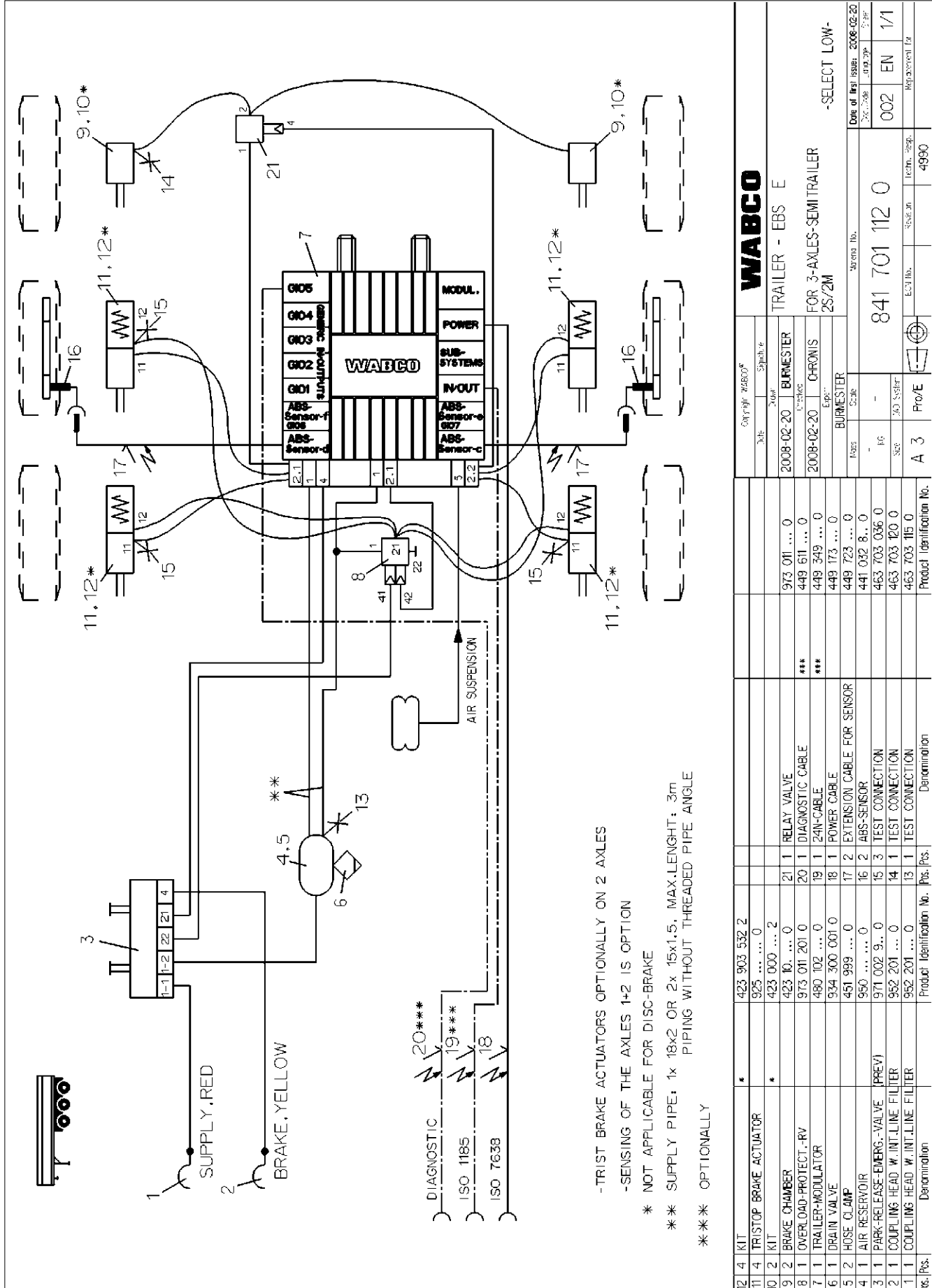

-TRISTOP BRAKE ACTUATORS OPTIONALLY ON 2 AXLES
 -SENSING OF THE AXLES 1+2 IS OPTION
 * NOT APPLICABLE FOR DISC-BRAKE
 ** SUPPLY PIPE; 1x 18x2 OR 2x 15x1.5, MAX.LEN.GHT: 3m
 PIPING WITHOUT THREADED PIPE ANGLE
 *** OPTIONALLY

Copyright WABCO®		Date		Signature	
		2008-02-20		BURNESTER	
		2008-02-20		CHRONIS	
		2008-02-20		BURNESTER	
Date of first issue: 2006-02-20		Version No.		Replacement for	
		841 701 112 0		002 EN 1/1	
Part No.		Scale		Technical description	
841 701 112 0		1:6		4990	
Part Name		Part No.		Part Description	
TRAILER - EBS E		A 3		Pro/E	
FOR 3-AXLES-SEMI TRAILER 2S/2M		4973 011 ... 0		973 011 ... 0	
		449 611 ... 0		449 611 ... 0	
		449 349 ... 0		449 349 ... 0	
		449 173 ... 0		449 173 ... 0	
		449 723 ... 0		449 723 ... 0	
		441 032 8... 0		441 032 8... 0	
		463 703 036 0		463 703 036 0	
		463 703 120 0		463 703 120 0	
		463 703 115 0		463 703 115 0	
Product Identification No.		Product Identification No.		Denomination	

WABCO
 TRAILER - EBS E
 FOR 3-AXLES-SEMI TRAILER
 2S/2M
 -SELECT LOW-

841 701 113 0

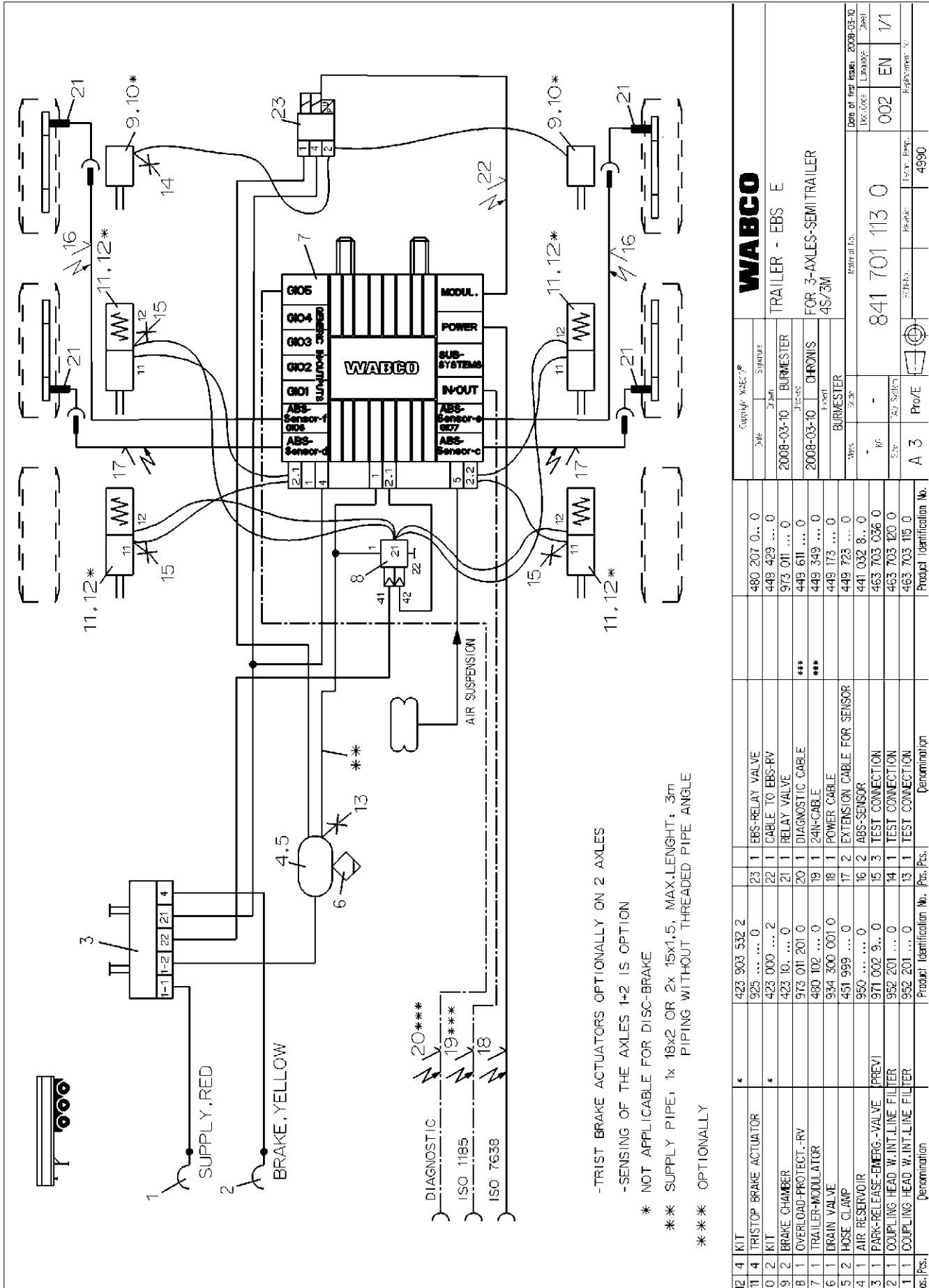

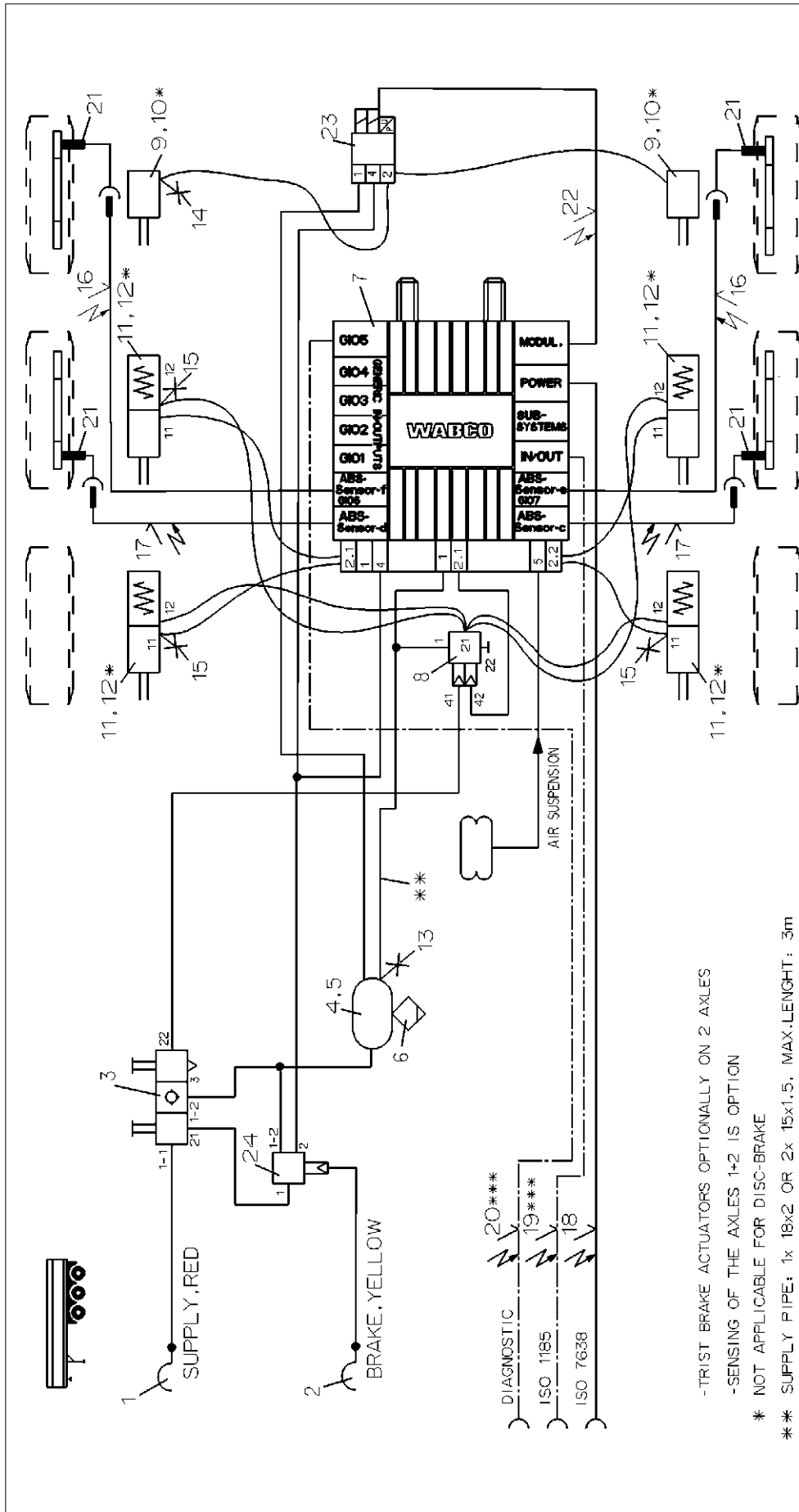

-TRISTOP BRAKE ACTUATORS OPTIONALLY ON 2 AXLES
 -SENSING OF THE AXLES 1-2 IS OPTION
 * NOT APPLICABLE FOR DISC-BRAKE
 ** SUPPLY PIPE: 1x 18x2 OR 2x 15x1.5, MAX-LENGTH: 3m
 PIPING WITHOUT THREADED PIPE ANGLE
 *** OPTIONALLY

12	4	KIT	*	423 903 532 2	24	1	EMERGENCY VALVE	971 002 301 0
11	4	TRISTOP BRAKE ACTUATOR	*	925 ... 0	23	1	EBB-RELAY VALVE	480 207 0... 0
10	2	KIT	*	423 000 ... 2	22	1	CABLE TO EBS-RV	449 429 ... 0
9	2	BRAKE CHAMBER		423 10... 0	21	4	ABS-SENSOR	441 032 8... 0
8	1	OVERLOAD-PROTECT-RV		973 011 201 0	20	1	DIAGNOSTIC CABLE	449 611 ... 0
7	1	TRAILER-MODULATOR		480 102 ... 0	19	1	24N-CABLE	449 349 ... 0
6	1	DRAIN VALVE		934 300 001 0	18	1	POWER CABLE	449 173 ... 0
5	2	HOSE CLAMP		451 999 ... 0	17	2	EXTENSION CABLE FOR SENSOR	449 723 ... 0
4	1	AIR RESERVOIR		950 ... 0	16	2	EXTENSION CABLE FOR SENSOR	449 723 ... 0
3	1	TRAILER-RELEASE-VALVE		963 001 05... 0	15	3	TEST CONNECTION	463 703 036 0
2	1	COUPLING HEAD W. INT. LINE FILTER		952 201 ... 0	14	1	TEST CONNECTION	463 703 120 0
1	1	COUPLING HEAD W. INT. LINE FILTER		952 201 ... 0	13	1	TEST CONNECTION	463 703 115 0
Pos./Pcs.	Denomination	Product Identification No.	Pos./Pcs.	Denomination	Product Identification No.			

WABCO		Copyright WABCO®
File	Drawn	Signature
2008-04-21	BURMESTER	
2008-04-21	CHRONIS	
FOR 3-AXLES-SEMI TRAILER 4S/3M		
Model No.	841 701 114 0	
Part No.		
Rev. No.		
ECN No.		
Pro/E		
Product Identification No.	4990	
Date of first issue: 2008-04-21		
Doc. Code	EN	1/1
Sheet		

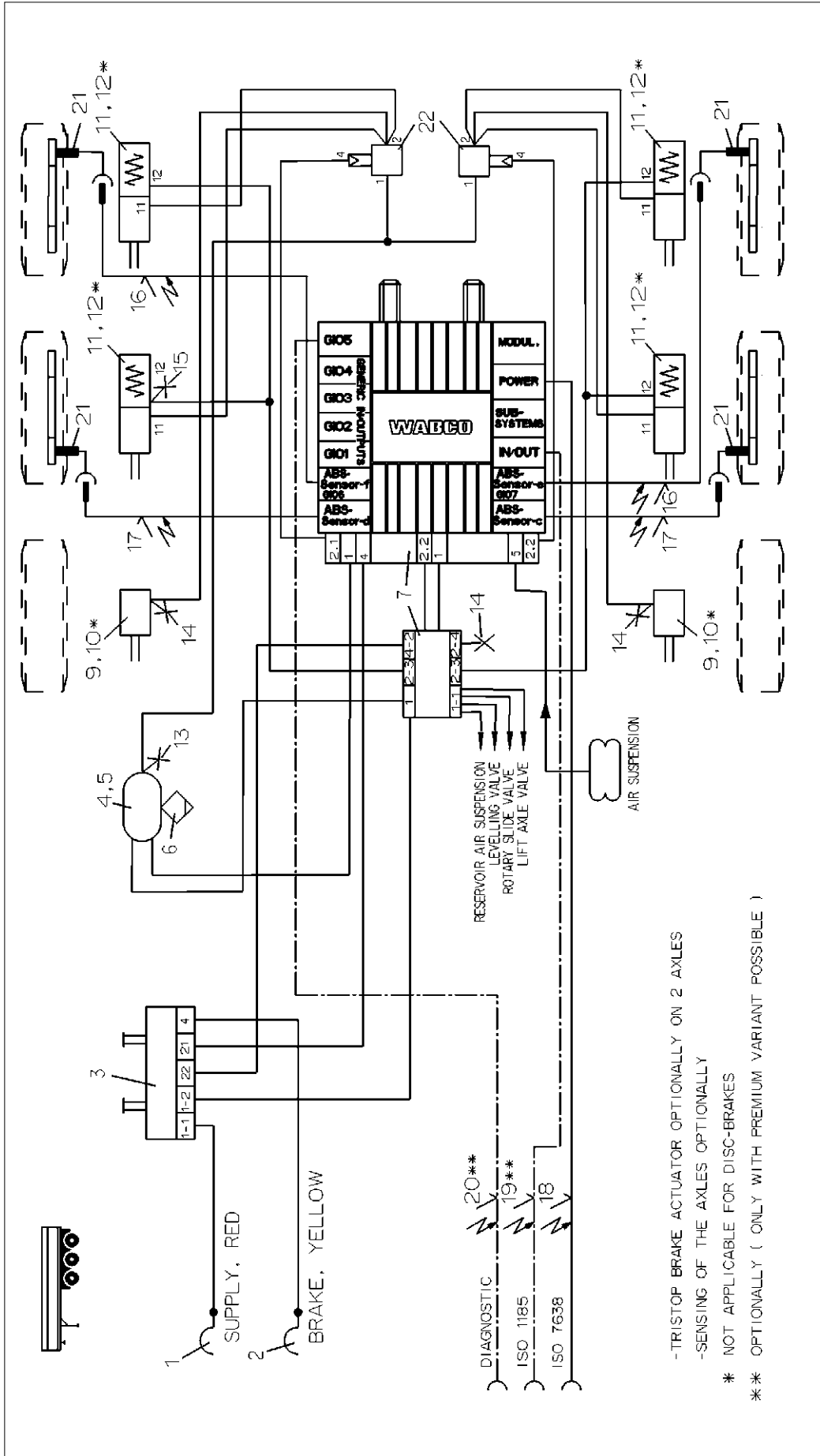

-TRISTOP BRAKE ACTUATOR OPTIONALLY ON 2 AXLES
 -SENSING OF THE AXLES OPTIONALLY
 * NOT APPLICABLE FOR DISC-BRAKES
 ** OPTIONALLY (ONLY WITH PREMIUM VARIANT POSSIBLE)

Part No.		Qty		Description		Remarks	
12	4	KIT	*	423 903 532 2			
11	4	TRISTOP BRAKE ACTUATOR		925 0			
10	2	KIT	*	423 000 2	22	2	RELAY VALVE
9	2	BRAKE CHAMBER		423 10. 0	21	4	ABS-SENSOR
8				449 611 0	20	1	DIAGNOSTIC CABLE
7	1	TRAILER-MODULATOR		480 102 0	19	1	24N-CABLE
6	1	DRAIN VALVE		934 300 001 0	18	1	SUPPLY (POWER) CABLE
5	2	HOSE CLAMP		451 999 0	17	2	EXTENSION CABLE FOR SENSOR
4	1	AIR RESERVOIR		950 0	16	2	EXTENSION CABLE FOR SENSOR
3	1	PARK-RELEASE-EMERGENCY VALVE (PREV)		971 002 9. 0	15	1	TEST CONNECTION
2	1	COUPLING HEAD W.INT. LINE FILTER		952 201 0	14	3	TEST CONNECTION
1	1	COUPLING HEAD W.INT. LINE FILTER		952 201 0	13	1	TEST CONNECTION
Denomination		Product Identification No.		Pos./Pcs.		Denomination	
A 3 Pro/E		463 703 115 0		A 3		463 703 115 0	
ECC-No.		841 701 115 0		ECC-No.		841 701 115 0	
Rec. No.		-		Rec. No.		-	
Tech. Rep.		-		Tech. Rep.		-	
4990		-		4990		-	
Request for		-		Request for		-	
002		-		002		-	
EN		-		EN		-	
1/1		-		1/1		-	
Date of last issue: 2008-10-07		-		Date of last issue: 2008-10-07		-	
Doc. Type: Drawing		-		Doc. Type: Drawing		-	
Sheet		-		Sheet		-	

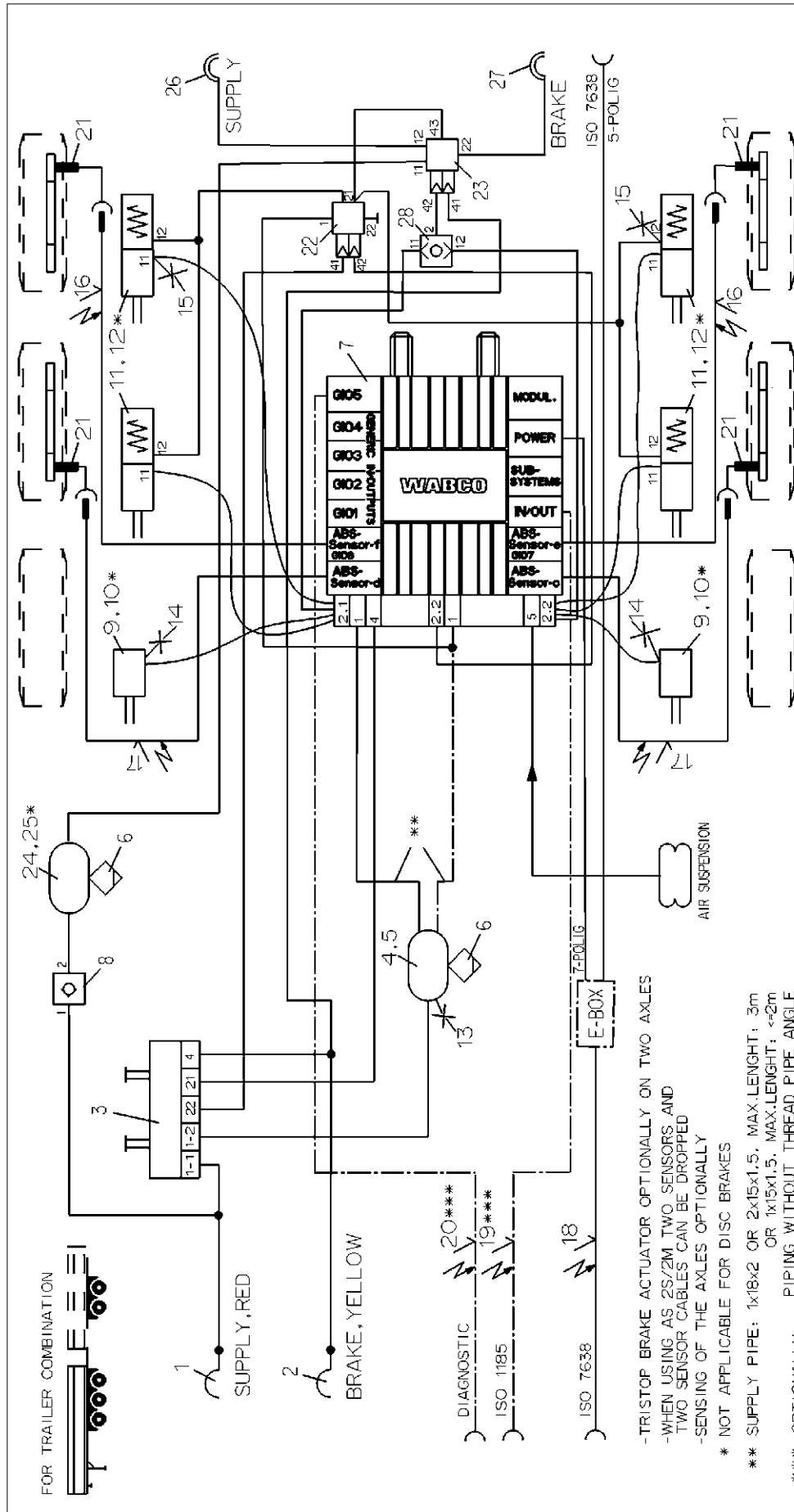

Fig. Pcs.	Denomination	Product Identification No.	Pcs.	Denomination	Product Identification No.
14	2 TEST CONNECTION	463 703 120 0	28	1 TWO WAY VALVE	434 208 029 0
13	1 TEST CONNECTION	463 703 115 0	27	1 COUPLING HEAD AUTOM. BRAKE	952 200 222 0
12	4 KIT	423 903 532 2	26	1 COUPLING HEAD AUTOM. SUPPLY	952 200 221 0
11	4 TRISTOP BRAKE ACTUATOR	925 0	25	2 HOSE CLAMP	451 999 ... 2
10	2 KIT	423 000 ... 0	24	1 AIR RESERVOIR	950 0
9	2 BRAKE CHAMBER	423 10 ... 0	23	1 TRAILER CONTROL VALVE	973 009 002 0
8	1 CHECK VALVE	434 014 000 0	22	1 OVERLOAD PROTECTION RV	973 011 201 0
7	1 TRAILER-MODULATOR W. EXTENSION MODUL	480 102 ... 0	21	4 ABS-SENSOR	441 032 8... 0
6	2 DRAIN VALVE	934 300 001 0	20	1 DIAGNOSTIC CABLE	449 611 ... 0
5	2 HOSE CLAMP	451 999 ... 2	19	1 24N-CABLE	449 349 ... 0
4	1 AIR RESERVOIR	950 0	18	1 SUPPLY (POWER) CABLE	449 173 ... 0
3	1 PARK-RELEASE-EMERG.-VALVE (REV)	971 002 9... 0	17	2 EXTENSION CABLE FOR SENSOR	449 723 ... 0
2	1 COUPLING HEAD W. INT. LINE FILTER	952 201 ... 0	16	2 EXTENSION CABLE FOR SENSOR	449 723 ... 0
1	1 COUPLING HEAD W. INT. LINE FILTER	952 201 ... 0	15	2 TEST CONNECTION	463 703 036 0

-TRISTOP BRAKE ACTUATOR OPTIONALLY ON TWO AXLES
 -WHEN USING AS 2S/2M TWO SENSORS AND TWO SENSOR CABLES CAN BE DROPPED
 -SENSING OF THE AXLES OPTIONALLY
 * NOT APPLICABLE FOR DISC BRAKES
 ** SUPPLY PIPE: 1x18x2 OR 2x15x1.5, MAX. LENGTH: 3m OR 1x15x1.5, MAX. LENGTH: <=2m
 *** OPTIONALLY PIPING WITHOUT THREAD PIPE ANGLE

WABCO

TRAILER - EBS E
 FOR 3-AXLES SEMITRAILER
 4S/2M OR 2S/2M
 WITH CONTROL FOR 2-AXLES-CAT

Part No. 1-91 150-000-000-00-14	Doc. Code	Europe	Sheet
841 701 116 0	002	EN	1/1
Pro/E	A 3	Rev. No.	4990

841 701 117 0

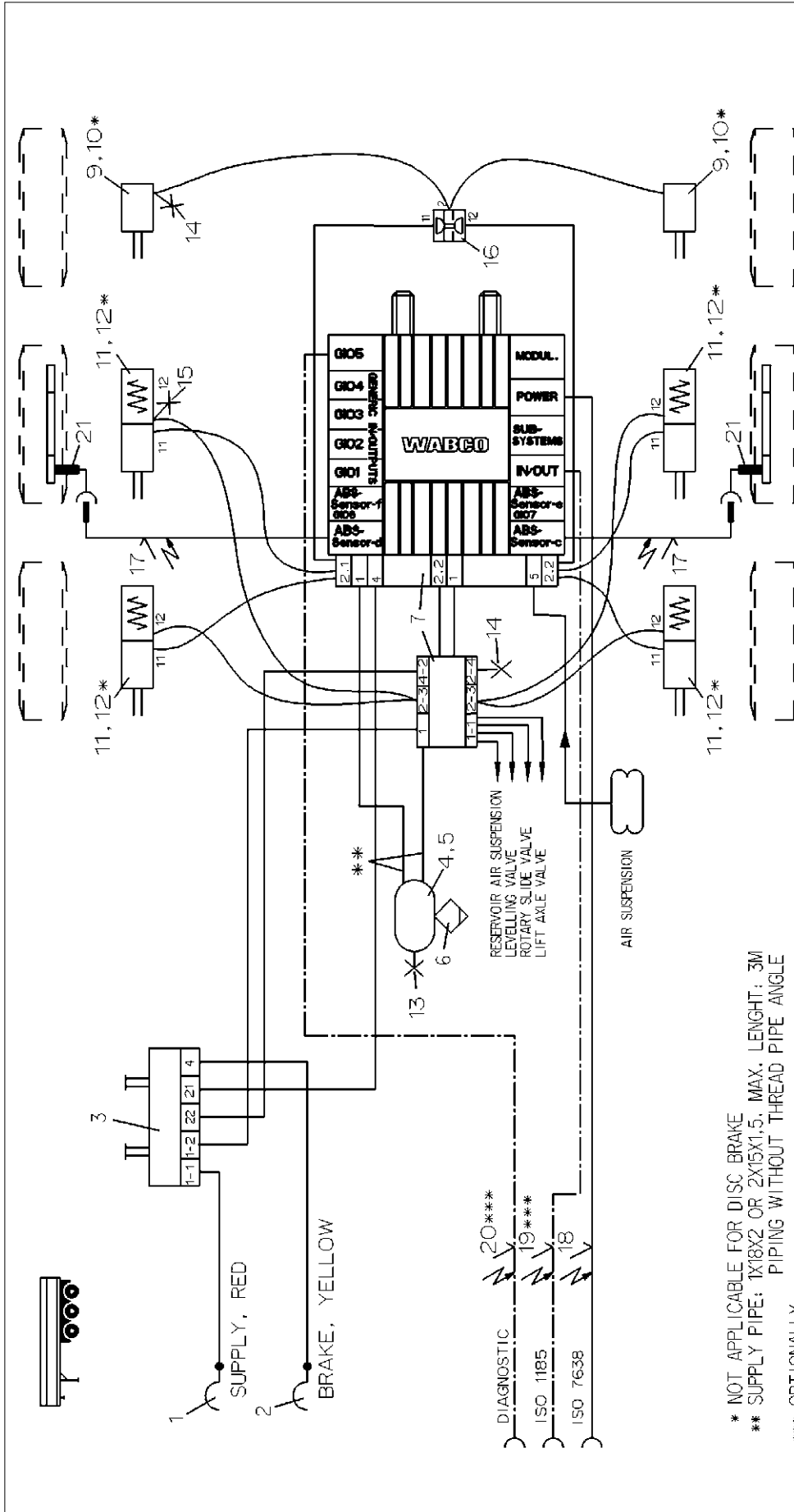

* NOT APPLICABLE FOR DISC BRAKE
 ** SUPPLY PIPE: 1X18X2 OR 2X15X1.5, MAX. LENGTH: 3M
 PIPING WITHOUT THREAD PIPE ANGLE
 *** OPTIONALLY

Part No.		Description		Quantity	
2	4	423 903 532 2			
11	4	925 0			
0	2	423 000 ... 2			
9	2	423 10 ... 0	21	2	ABS-SENSOR
8			20	1	DIAGNOSTIC CABLE
7	1	480 102 ... 0	19	1	24N-CABLE
6	1	934 300 001 0	18	1	SUPPLY (POWER) CABLE
5	2	451 999 ... 2	17	2	EXTENSION CABLE FOR SENSOR
4	1	950 0	16	1	DOUBLE CHECK VALVE
3	1	971 002 9 ... 0	15	1	TEST CONNECTION
2	1	962 201 ... 0	14	2	TEST CONNECTION
1	1	952 201 ... 0	13	1	TEST CONNECTION
Denomination		Product Identification No.	Pos./Pcs.	Denomination	
A 3		841 701 117 0		4990	
Pro/E		EDH.L.	Revis.	4990	
-		841 701 117 0	002	EN 1/1	
-		BURMESTER	002	EN 1/1	
-		2010-06-07		2010-06-07	
-		2010-06-07		2010-06-07	
-		BURMESTER		BURMESTER	
-		441 032 8 ... 0		441 032 8 ... 0	
-		449 611 ... 0		449 611 ... 0	
-		449 349 ... 0		449 349 ... 0	
-		449 173 ... 0		449 173 ... 0	
-		449 723 ... 0		449 723 ... 0	
-		434 500 003 0		434 500 003 0	
-		463 703 036 0		463 703 036 0	
-		463 703 120 0		463 703 120 0	
-		463 703 115 0		463 703 115 0	
-		463 703 115 0		463 703 115 0	

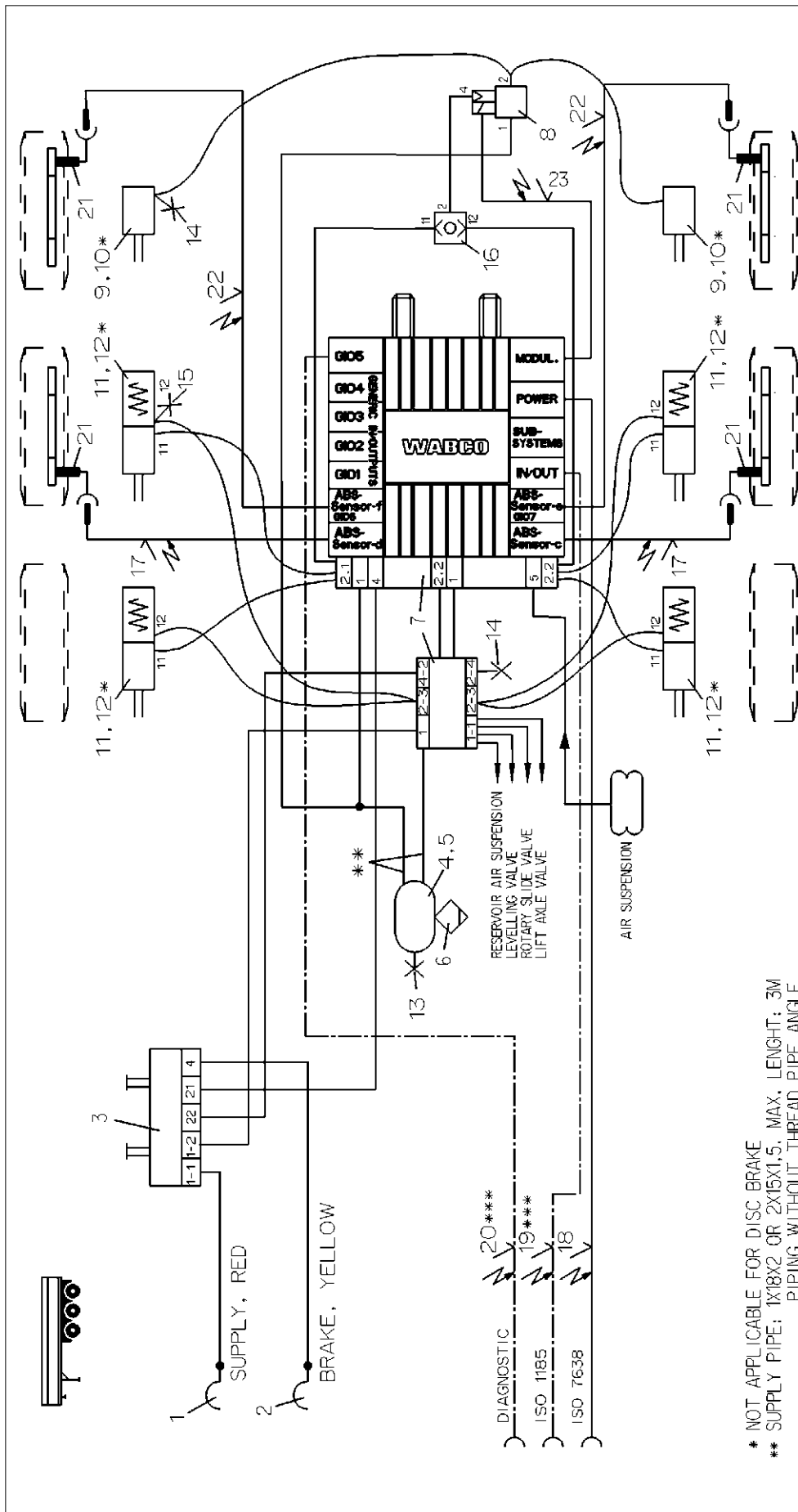

* NOT APPLICABLE FOR DISC BRAKE
 ** SUPPLY PIPE: 1X18X2 OR 2X15X1,5. MAX. LENGTH: 3M
 PIPING WITHOUT THREAD PIPE ANGLE
 *** OPTIONALLY

2	4	Kit	423 903 532 2				23	1				
10	4	TRISTOP BRAKE ACTUATOR	925 0	23	1	CABLE TO ABS-RELAY VALVE	449 436 ... 0					
0	2	KIT	423 000 ... 2	22	2	EXTENSION CABLE FOR SENSOR	449 723 ... 0					
9	2	BRAKE CHAMBER	423 10 0	21	4	ABS-SENSOR	441 032 8 ... 0					
8	1	ABS-RELAY VALVE	972 195 037 0	20	1	DIAGNOSTIC CABLE	449 611 ... 0					
7	1	TRAILER-MODULATOR W. EXTENSION MODUL.	480 102 ... 0	19	1	24M-CABLE	449 349 ... 0					
6	1	HOSE CLAMP	934 300 001 0	18	1	SUPPLY (POWER) CABLE	449 173 ... 0					
5	2	AIR RESERVOIR	451 999 ... 2	17	2	EXTENSION CABLE FOR SENSOR	449 723 ... 0					
4	1	PARK-RELEASE-EMERG.-VALVE (PREVI	950 0	16	1	TWO WAY VALVE	424 208 0 ... 0					
3	1	COUPLING HEAD W. INT.LINE FILTER	971 002 9 ... 0	15	1	TEST CONNECTION	463 703 036 0					
2	1	COUPLING HEAD W. INT.LINE FILTER	952 201 ... 0	14	2	TEST CONNECTION	463 703 129 0					
1	1	COUPLING HEAD W. INT.LINE FILTER	952 201 ... 0	13	1	TEST CONNECTION	463 703 115 0					
1	1	Denominator	Product Identification No. Pos. Pcs.	1	1	Denominator	Product Identification No. Pos. Pcs.					

Citygraph WABCO®		WABCO	
Sub	Spachtel	TRAILER - EBS E FOR 3-AXLES-SEMI TRAILER 4S/2M+TM	
2010-06-07	BURMESTER	-PEM-	
2010-06-07	CHRONIS		
Type: BURMESTER			
Max. Scale		Vehicle No.	
kg		841 701 118 0	
1/1		Date of first issue: 2010-06-07	
A 3 Pro/E		Dwg. Code: L2_A000	
		Sheet	
		002 EN 1/1	
		Application for	
4990		4990	

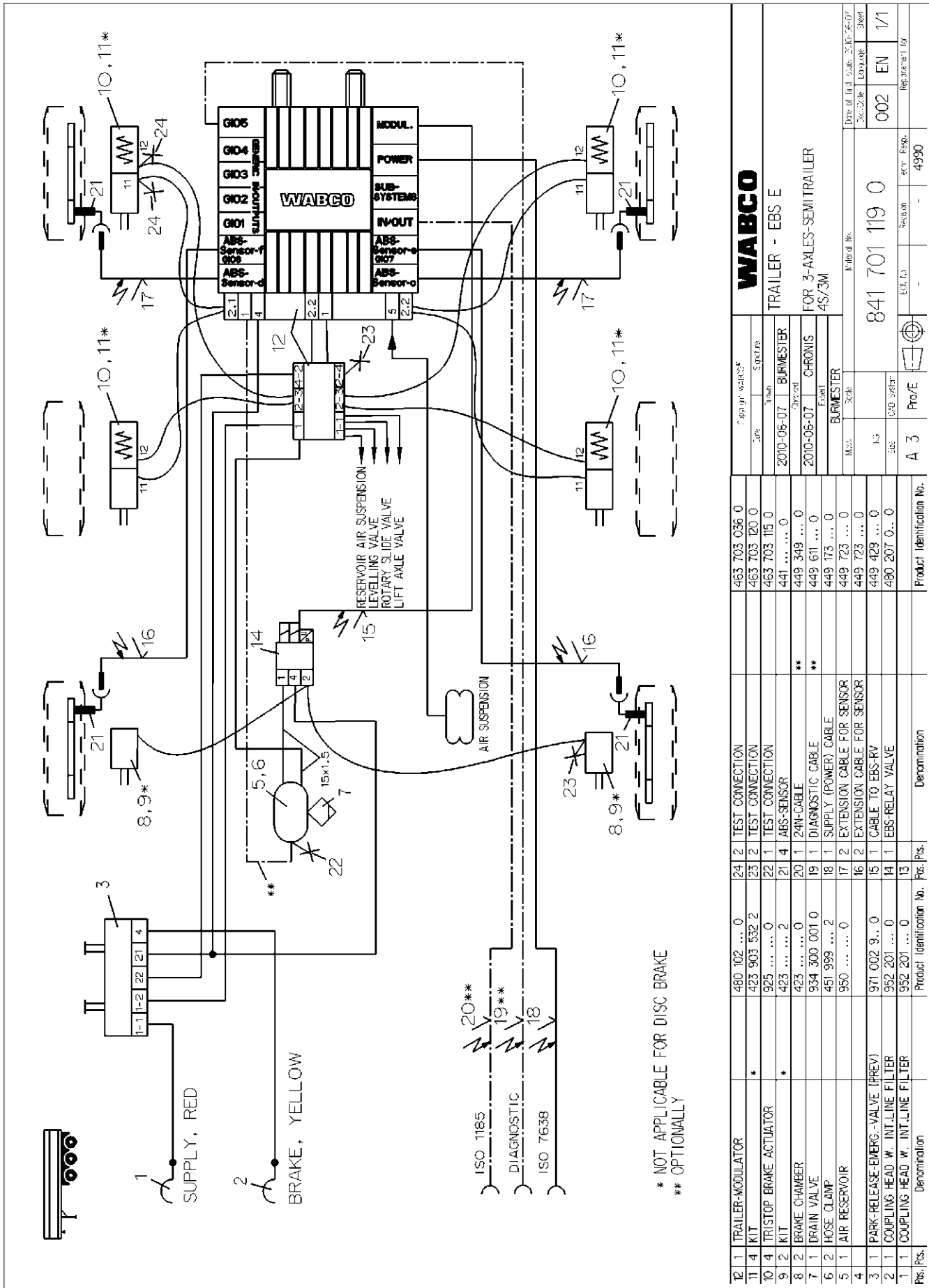

* NOT APPLICABLE FOR DISC BRAKE
** OPTIONAL

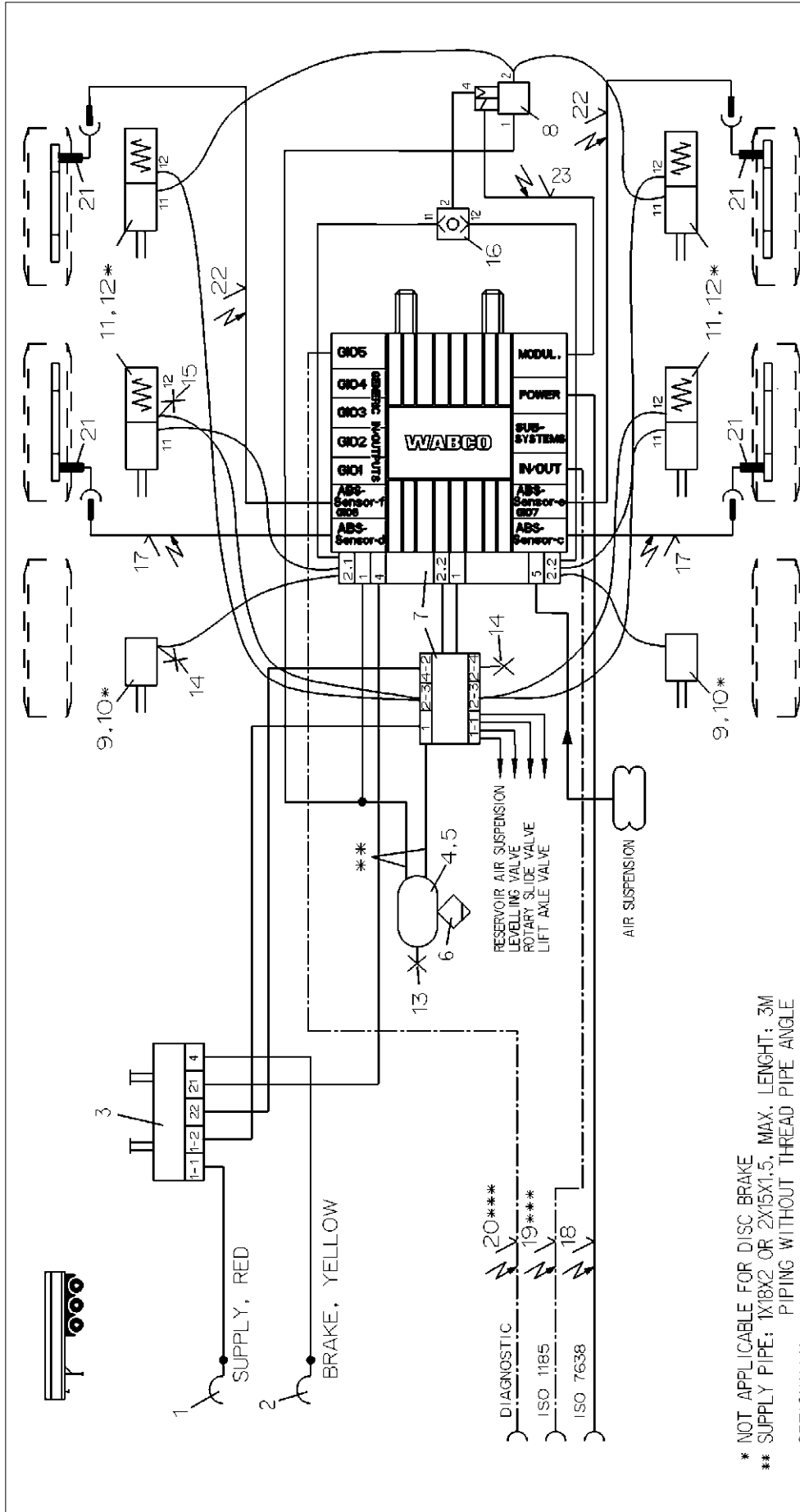

* NOT APPLICABLE FOR DISC BRAKE
 ** SUPPLY PIPE; 1X18X2 OR 2X15X1.5, MAX. LENGTH; 3M
 PIPING WITHOUT THREAD PIPE ANGLE
 *** OPTIONALLY

Part No.		Description	Qty.	Unit	Product Identification No.	Denomination
12	4	KIT	*	423 903 532 2		
11	4	TRISTOP BRAKE ACTUATOR		925 0	23 1	CABLE TO ABS-RELAY VALVE
10	2	KIT		423 000 ... 2	22 2	EXTENSION CABLE FOR SENSOR
9	2	BRAKE CHAMBER		423 10 ... 0	21 4	ABS-SENSOR
8	1	ABS-RELAY VALVE		972 195 037 0	20 1	DIAGNOSTIC CABLE
7	1	TRAILER-MODULATOR W. EXTENSION MODUL.		480 102 ... 0	19 1	24IN-CABLE
6	1	DRAIN VALVE		934 300 001 0	18 1	SUPPLY (POWER) CABLE
5	2	HOSE CLAMP		451 999 ... 2	17 2	EXTENSION CABLE FOR SENSOR
4	1	AIR RESERVOIR		960 0	16 1	TWO-WAY VALVE
3	1	PARK-RELEASE-EMERG.-VALVE (REV)		971 002 9... 0	15 1	TEST CONNECTION
2	1	COUPLING HEAD W. INT.LINE FILTER		952 201 ... 0	14 2	TEST CONNECTION
1	1	COUPLING HEAD W. INT.LINE FILTER		952 201 ... 0	13 1	TEST CONNECTION

Date	Signature	Part No.	Checked	Drawn	Scale	Proj. No.	Rev. No.	Proj. Name	Quantity
2010-06-08	BURMESTER	2010-06-08	BURMESTER						
2010-06-08	CHRONIS	2010-06-08	CHRONIS						

WABCO		TRAILER - EBS E		FOR 3-AXLES-SEMI-TRAILER		4S/2M+1M	
Part No.	841 701 221 0	Part No.		Part No.		Part No.	
Quantity	1	Quantity		Quantity		Quantity	
Weight	130 lbs.	Weight		Weight		Weight	
Material	Pro/E	Material		Material		Material	
Product Identification No.	4930	Product Identification No.		Product Identification No.		Product Identification No.	

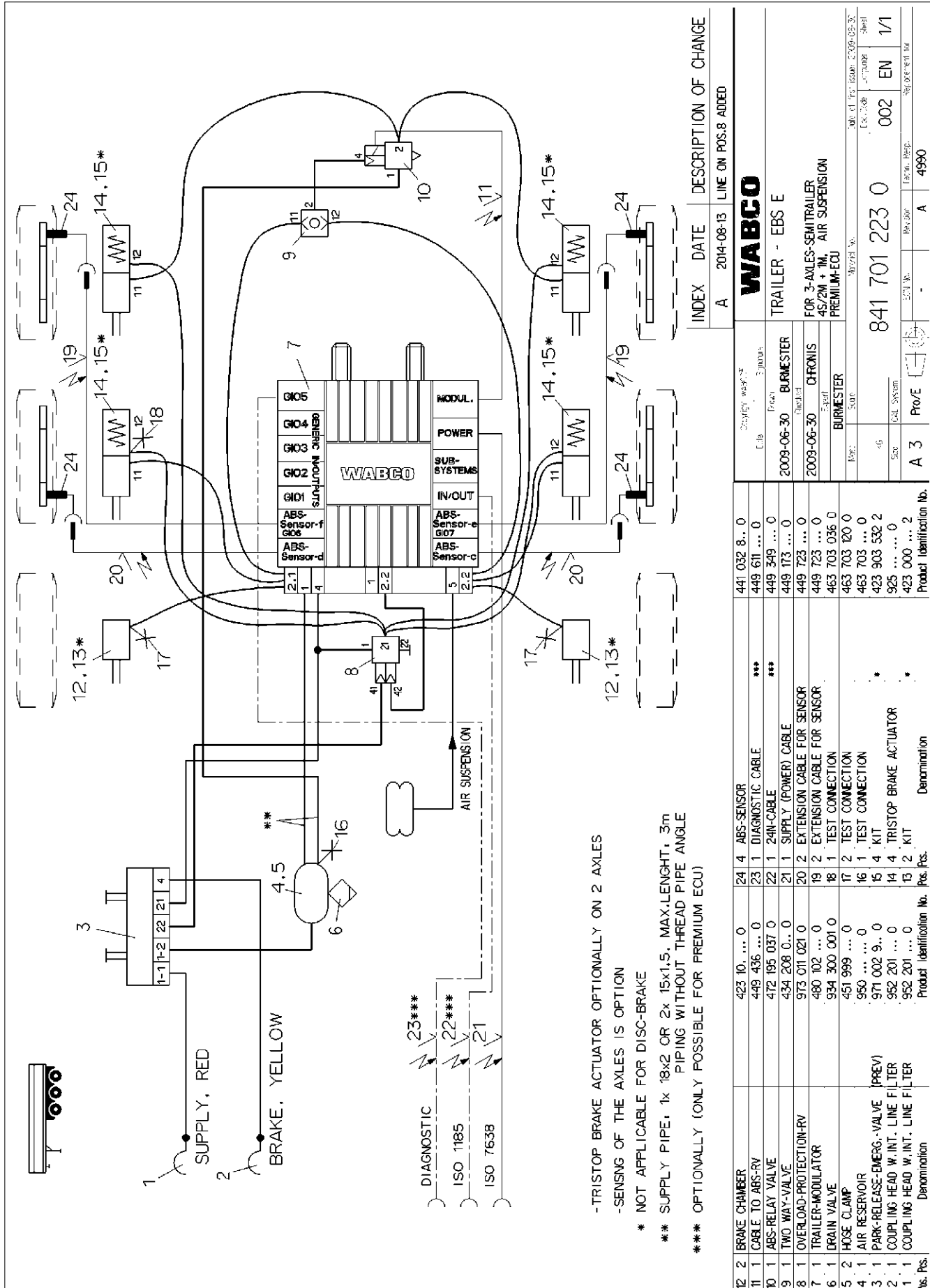

-TRISTOP BRAKE ACTUATOR OPTIONALLY ON 2 AXLES
 -SENSING OF THE AXLES IS OPTION
 * NOT APPLICABLE FOR DISC-BRAKE
 ** SUPPLY PIPE: 1x 18x2 OR 2x 15x1.5. MAX.LENIGHT: 3m
 PIPING WITHOUT THREAD PIPE ANGLE
 *** OPTIONALLY (ONLY POSSIBLE FOR PREMIUM ECU)

INDEX	DATE	DESCRIPTION OF CHANGE
A	2014-08-13	LINE ON POS.8 ADDED

12	2	BRAKE CHAMBER	423 10 ... 0	24	4	ABS-SENSOR	441 032 8.. 0
11	1	CABLE TO ABS-RV	449 436 ... 0	23	1	DIAGNOSTIC CABLE	449 611 ... 0
10	1	ABS-RELAY VALVE	472 195 037 0	22	1	24N-CABLE	449 349 ... 0
9	1	TWO WAY-VALVE	434 208 0.. 0	21	1	SUPPLY (POWER) CABLE	449 173 ... 0
8	1	OVERLOAD-PROTECTION-RV	973 011 021 0	20	2	EXTENSION CABLE FOR SENSOR	449 723 ... 0
7	1	TRAILER-MODULATOR	480 702 ... 0	19	2	EXTENSION CABLE FOR SENSOR	449 723 ... 0
6	1	DRAIN VALVE	934 300 001 0	18	1	TEST CONNECTION	463 703 036 0
5	2	HOSE CLAMP	451 999 ... 0	17	2	TEST CONNECTION	463 703 120 0
4	1	AIR RESERVOIR	950 0	16	1	TEST CONNECTION	463 703 ... 0
3	1	PARK-RELEASE-EMERG.-VALVE (PREV)	971 002 9.. 0	15	4	KIT	423 903 532 2
2	1	COUPLING HEAD W.INT. LINE FILTER	952 201 ... 0	14	4	TRISTOP BRAKE ACTUATOR	925 0
1	1	COUPLING HEAD W.INT. LINE FILTER	952 201 ... 0	13	2	KIT	423 000 ... 2

WABCO	
TRAILER - EBS E	
FOR 3-AXLES-SEMI TRAILER	
4S/2M + IM. AIR SUSPENSION	
PREMIUM-ECU	
Part No.	841 701 223 0
Doc. No.	EN 1/1
Rev. No.	002
Lab. Resp.	A
Part No.	4990

841 701 224 0

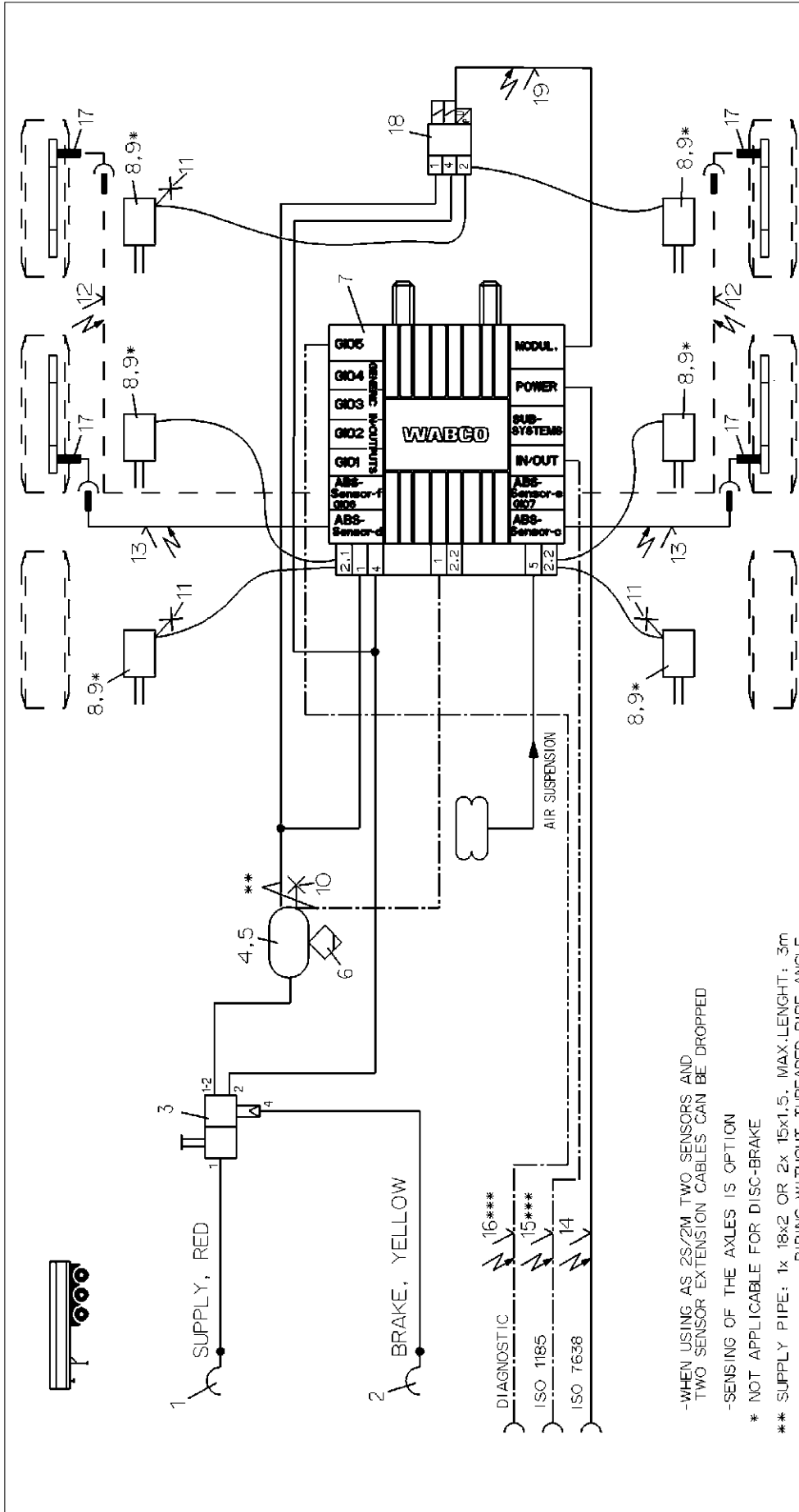

-WHEN USING AS 2S/2M TWO SENSORS AND TWO SENSOR EXTENSION CABLES CAN BE DROPPED
 -SENSING OF THE AXLES IS OPTION
 * NOT APPLICABLE FOR DISC-BRAKE
 ** SUPPLY PIPE: 1x 18x2 OR 2x 15x1,5, MAX. LENGTH : 3m PIPING WITHOUT THREADED PIPE ANGLE
 *** OPTIONALLY

Copyright WABCO®		WABCO	
Part No.	Signal No.	TRAILER - EBS E	
2009-07-B	BURMESTER	FOR 3-AXLES-SEMI TRAILER 4S/2M OR 4S/3M WITH TRAILER BRAKE VALVE	
2009-07-B	CHRONIS	Material No.	
BURMESTER	Level 1	841 701 224 0	
BURMESTER	Level 2	Date of first issue: 2009-12-15	
950 ... 999	***	No. of pages: 1	
950 001 013 04*	971 002 301 0	1/1	
952 201 ... 0	14 1 SUPPLY CABLE	EN	
952 201 ... 0	13 2 EXTENSION CABLE FOR SENSOR	EN	
952 201 ... 0	13 2 EXTENSION CABLE FOR SENSOR	EN	
Denomination	Product Identification No.	4990	
Denomination	Product Identification No.	4990	

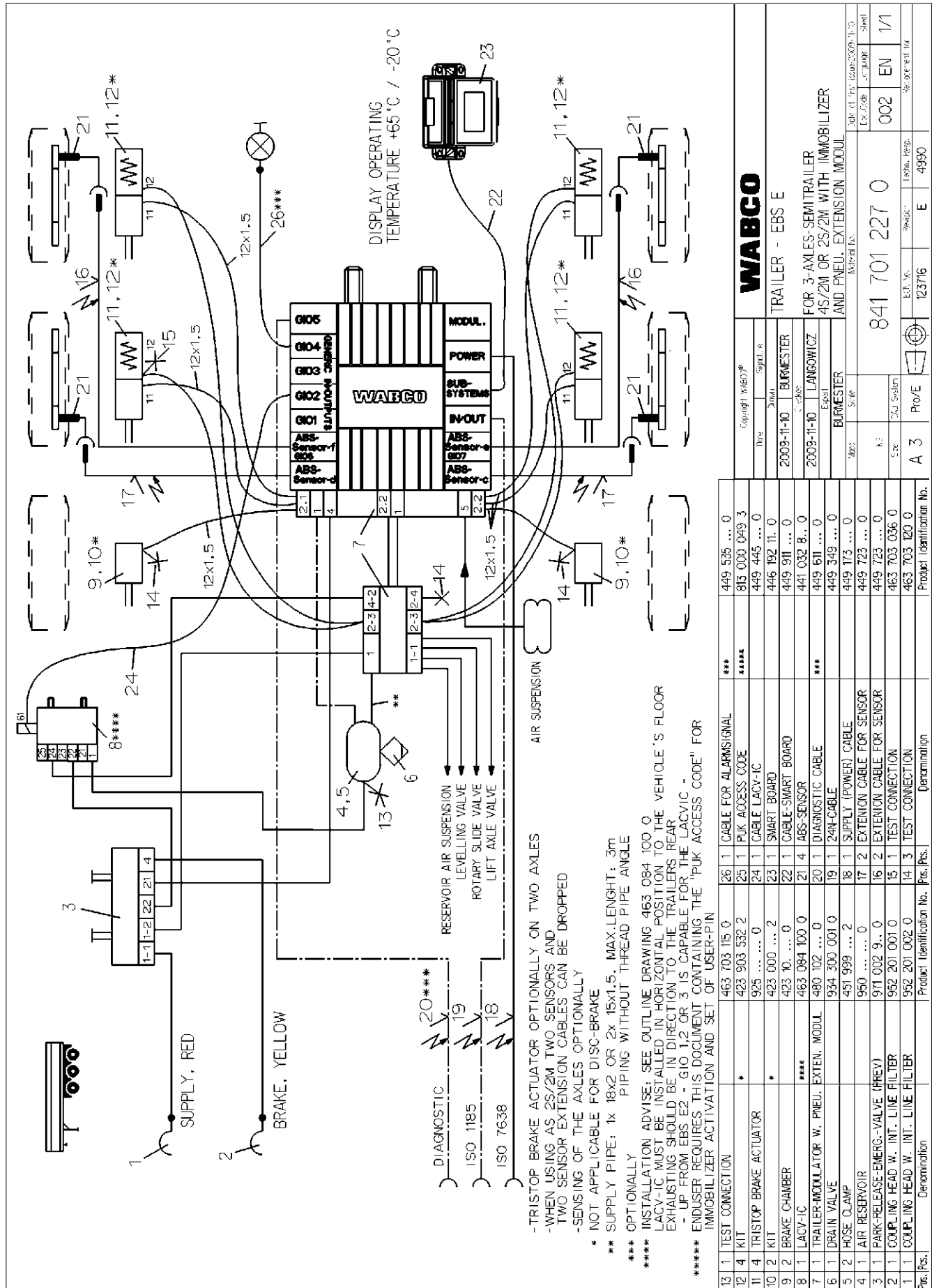

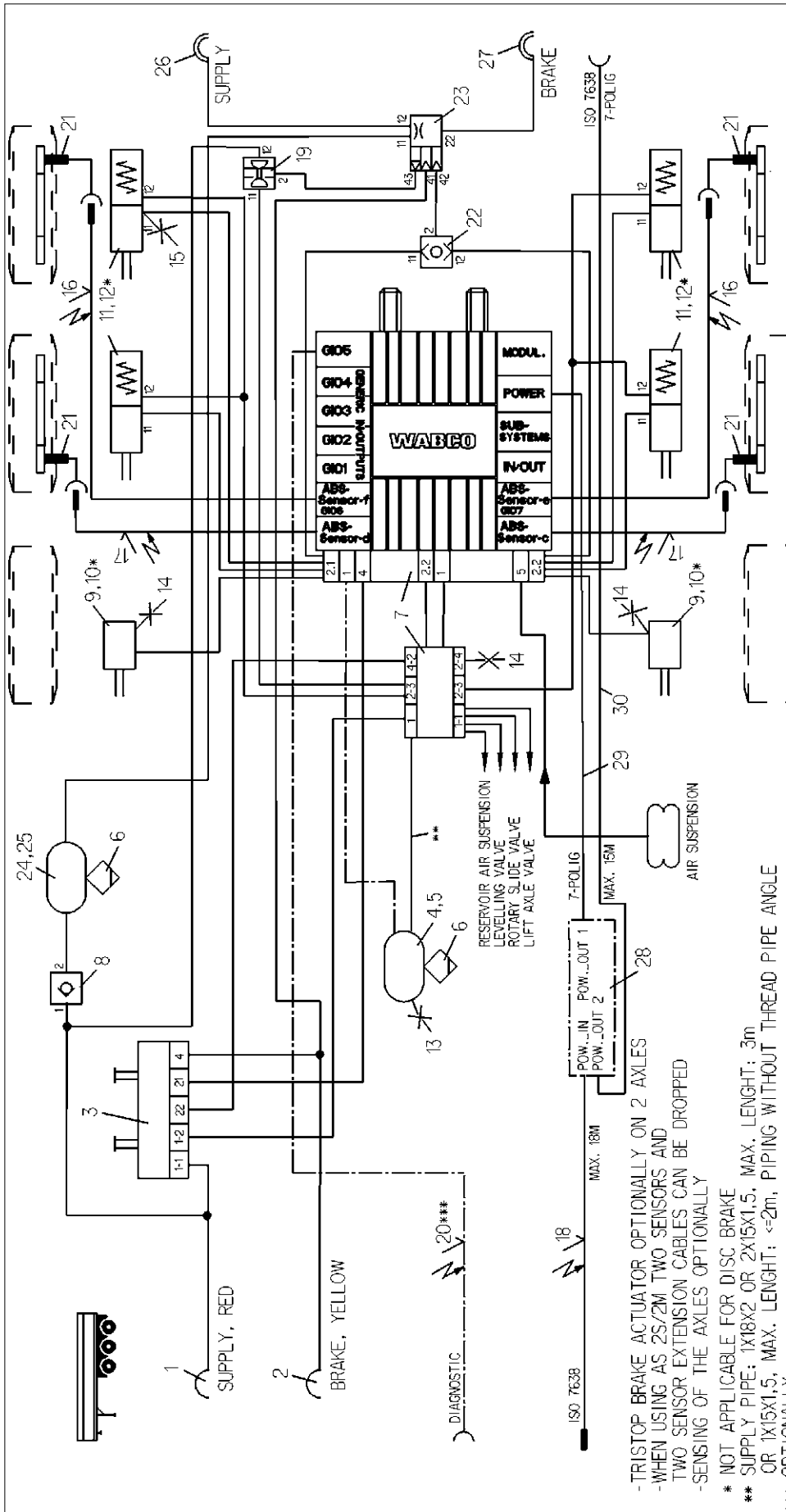

-TRISTOP BRAKE ACTUATOR OPTIONALLY ON 2 AXLES
 -WHEN USING AS 2S/2M TWO SENSORS AND TWO SENSOR EXTENSION CABLES CAN BE DROPPED
 -SENSING OF THE AXLES OPTIONALLY

* NOT APPLICABLE FOR DISC BRAKE
 ** SUPPLY PIPE: 1X18X2 OR 2X15X1,5. MAX. LENGTH: 3m
 OR 1X15X1,5. MAX. LENGTH: <=2m, PIPING WITHOUT THREAD PIPE ANGLE
 *** OPTIONAL

15	1	TEST CONNECTION	463 703 036 0	30	1	SUPPLY (POWER) CABLE	449 135 ... 0
14	3	TEST CONNECTION	463 703 120 0	29	1	SUPPLY (POWER) CABLE	449 347 ... 0
13	1	TEST CONNECTION	463 703 115 0	28	1	CAN-ROUTER	446 122 050 0
12	4	KIT	423 903 532 2	27	1	COUPLING HEAD AUTOM. BRAKE	952 200 222 0
11	4	TRISTOP BRAKE ACTUATOR	925 0	26	1	COUPLING HEAD AUTOM. SUPPLY	952 200 221 0
10	2	KIT	423 000 ... 0	25	2	HOSE CLAMP	451 999 ... 2
9	2	BRAKE CHAMBER	423 10 ... 0	24	1	AIR RESERVOIR	950 0
8	1	CHECK VALVE	434 014 000 0	23	1	TRAILER CONTROL VALVE	973 0
7	1	TRAILER-MODULATOR W/EXTENSION MODUL	480 102 ... 0	22	2	TWO WAY VALVE	434 208 02 0
6	2	DRAIN VALVE	934 300 001 0	21	4	ABS-SENSOR	441 032 8... 0
5	2	HOSE CLAMP	451 999 ... 2	20	1	DIAGNOSTIC CABLE	***
4	1	AIR RESERVOIR	950 0	19	1	DOUBLE CUT-OFF VALVE	434 500 003 0
3	1	PARK-RELEASE-EMERG.-VALVE (PREV)	971 002 9... 0	18	1	SUPPLY (POWER) CABLE	449 135 ... 0
2	1	COUPLING HEAD W. INT.-LINE FILTER	952 201 ... 0	17	2	EXTENSION CABLE FOR SENSOR	449 723 ... 0
1	1	COUPLING HEAD W. INT.-LINE FILTER	952 201 ... 0	16	2	EXTENSION CABLE FOR SENSOR	449 723 ... 0

Product Identification No.	Denomination	Pcs./Pcs.
A 3	Pro/E	129338
50th. No.	Position	Doc. Resp.
841 701 228 0	A	4990
Version No.	Material No.	
002	EN	1/1
Date of first issue: 2010-03-09	Steel	

WABCO	
TRAILER - EBS E	
WITH CAN-ROUTER	
4S/2M OR 2S/2M	
Date	Subtype
2010-03-09	BURMESTER
Cable:	
2010-03-09	CHRONIS
Type:	
BURMESTER	

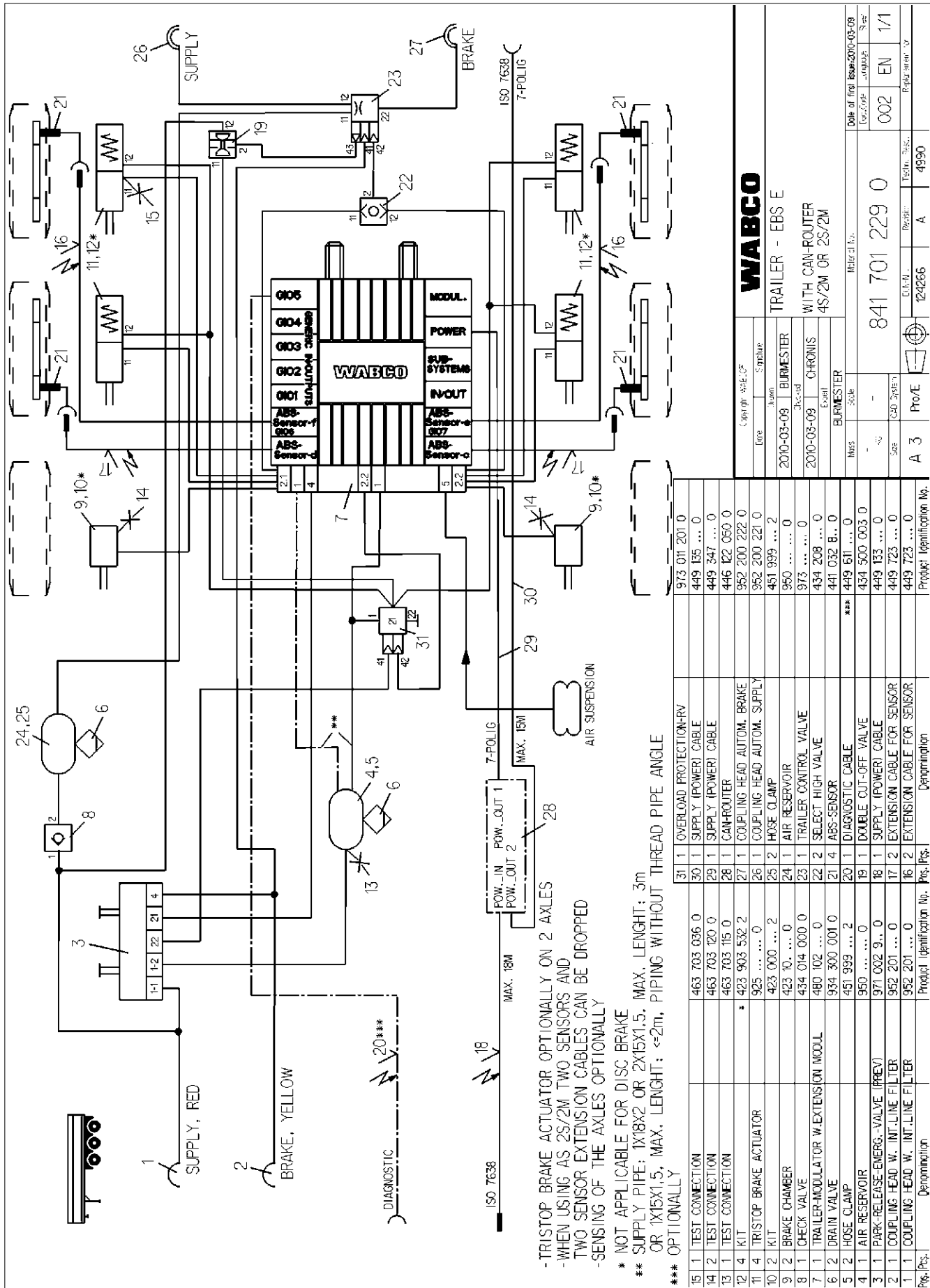

WABCO
TRAILER - EBS E
WITH CAN-ROUTER
4S/2M OR 2S/2M

Part No. 841 701 229 0
Date of first issue: 2010-03-09
Rev. 002 EN 1/1

Fig. (Pcs.) A 3
Pcs. (Pcs.) 124266
Rev. (Pcs.) A
Part No. 4990

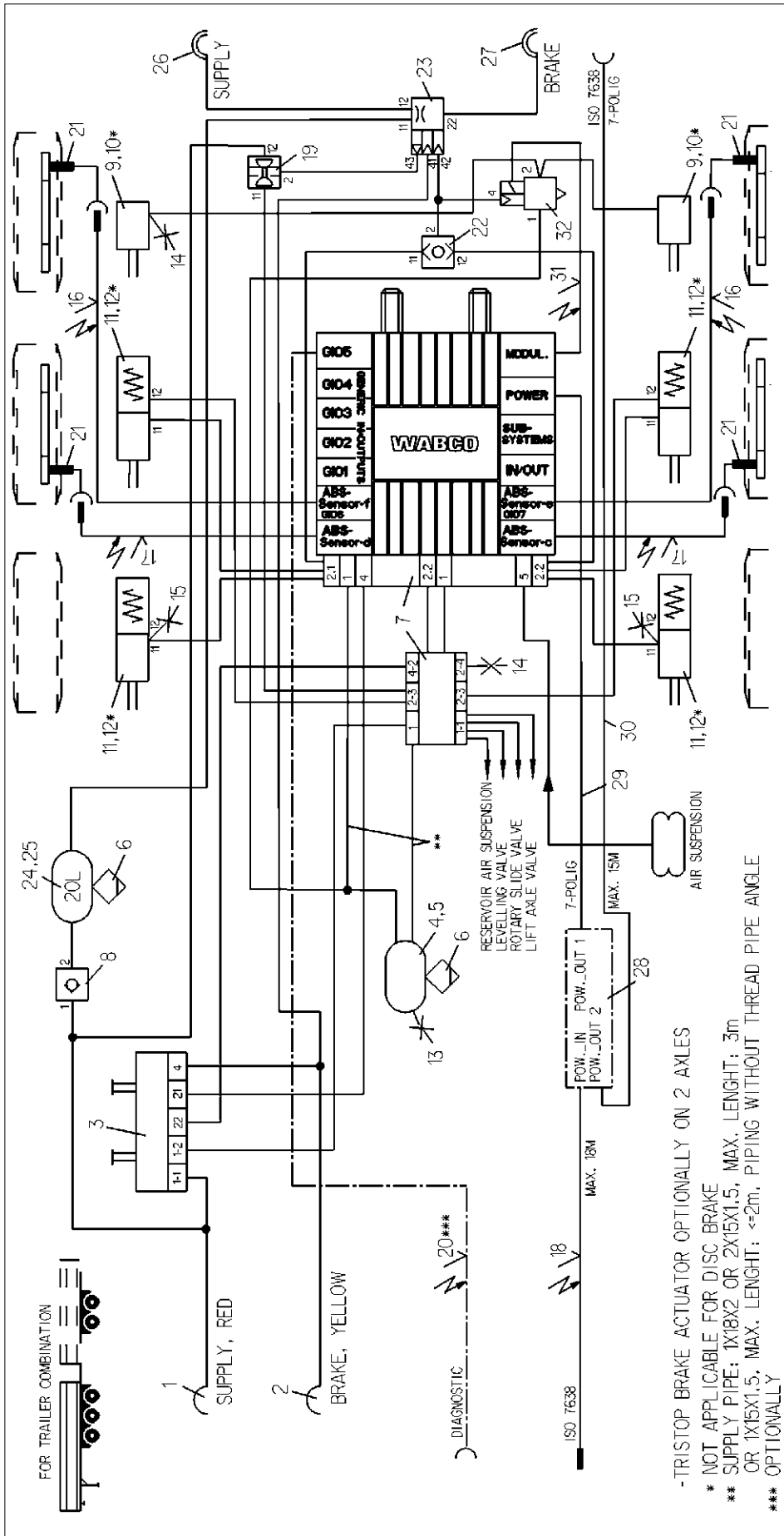

-TRISTOP BRAKE ACTUATOR OPTIONALLY ON 2 AXLES
 * NOT APPLICABLE FOR DISC BRAKE
 ** SUPPLY PIPE: 1X18X2 OR 2X15X1,5, MAX. LENGTH: 3m
 OR 1X15X1,5, MAX. LENGTH: $\leq 2\text{m}$, PIPING WITHOUT THREAD PIPE ANGLE
 *** OPTIONALLY

Pos./Pcs.	Denomination	Product Identification No.	Pos./Pcs.	Denomination	Product Identification No.
16 2	EXTENSION CABLE FOR SENSOR	449 723 ... 0	32 1	ABS-RELAY VALVE	972 195 037 0
19 2	TEST CONNECTION	463 703 036 0	31 1	CABLE TO ABS-RELAY VALVE	449 436 ... 0
14 2	TEST CONNECTION	463 703 120 0	30 1	SUPPLY (POWER) CABLE	449 135 ... 0
13 1	TEST CONNECTION	463 703 115 0	29 1	SUPPLY (POWER) CABLE	449 347 ... 0
12 4	KIT	423 903 532 2	28 1	CAN-ROUTER	446 122 050 0
11 4	TRISTOP BRAKE ACTUATOR	925 ... 0	27 1	COUPLING HEAD AUTOM. BRAKE	952 200 222 0
10 2	KIT	423 000 ... 0	26 1	COUPLING HEAD AUTOM. SUPPLY	952 200 221 0
9 2	BRAKE CHAMBER	423 10 ... 0	25 2	HOSE CLAMP	451 999 ... 2
8 1	CHECK VALVE	434 014 000 0	24 1	AIR RESERVOIR	950 ... 0
7 1	TRAILER-MODULATOR W/EXTENSION MODUL	480 102 ... 0	23 1	TRAILER CONTROL VALVE	973 ... 0
6 2	DRAIN VALVE	934 300 001 0	22 2	SELECT HIGH VALVE	434 208 ... 0
5 2	HOSE CLAMP	451 999 ... 2	21 4	ABS-SENSOR	441 032 8... 0
4 1	AIR RESERVOIR	950 ... 0	20 1	DIAGNOSTIC CABLE	449 611 ... 0
3 1	PARK-RELEASE-EMERG.-VALVE (PREV)	971 002 9... 0	19 1	DOUBLE CUT-OFF VALVE	434 500 003 0
2 1	COUPLING HEAD W. INT.LINE FILTER	952 201 ... 0	18 1	SUPPLY (POWER) CABLE	449 133 ... 0
1 1	COUPLING HEAD W. INT.LINE FILTER	952 201 ... 0	17 2	EXTENSION CABLE FOR SENSOR	449 723 ... 0

WABCO
 TRAILER - EBS E
 FOR 3-AXLES-SEMI-TRAILER
 WITH CAN-ROUTER
 4S/2M +1M

Part No.	841 701 230 0	Revision	002
Part Name	TRAILER - EBS E	Part No.	EN
Part No.	841 701 230 0	Revision	002
Part Name	TRAILER - EBS E	Part No.	EN

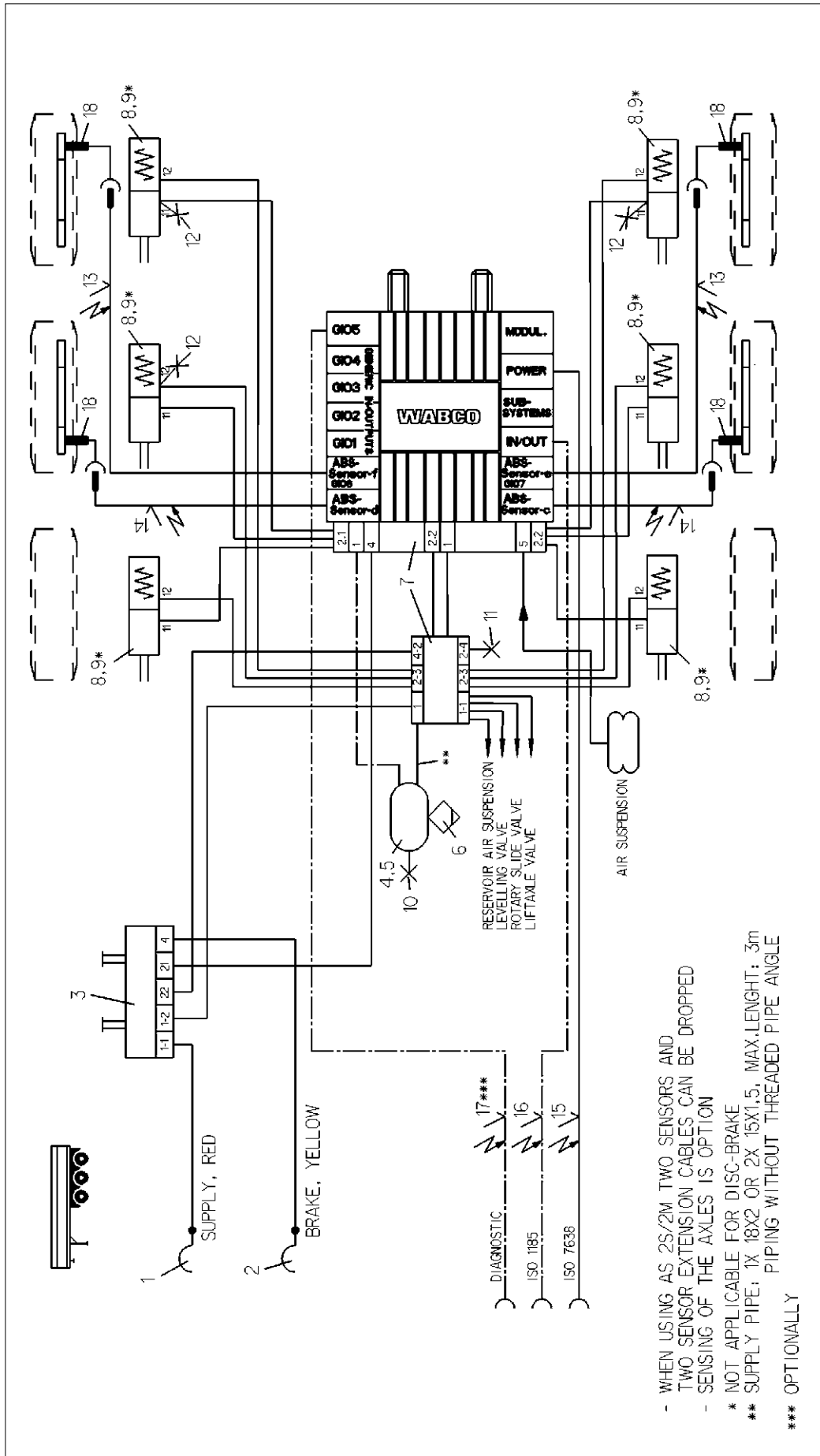

Date		Symbol		Title	
2010-04-27	BURMESTER	2010-04-27	BURMESTER	TRAILER - EBS E	
2010-04-27	CHRONIS	2010-04-27	CHRONIS	FOR 3-AXLES-SEMI TRAILER	
Part		Part		Material No.	
BURMESTER		BURMESTER		4S/2M OR 2S/2M - PEM -	
4S		4S		841 701 231 0	
EN		EN		002	
1/1		1/1		EN 1/1	
Product Identification No.		Product Identification No.		Product Identification No.	
Denomination		Denomination		Denomination	
Pos./Pcs.		Pos./Pcs.		Pos./Pcs.	
12	3	463 703 036 0			
11	1	463 703 120 0			
10	1	463 703 115 0			
9	6	* 423 903 532 2			
8	6	925 0			
7	1	480 102 ... 0			
6	1	934 300 001 0	18	4	ABS-SENSOR
5	2	451 999 ... 2	17	1	DIAGNOSTIC CABLE
4	1	950 0	16	1	24N-CABLE
3	1	971 002 9... 0	15	1	SUPPLY (POWER) CABLE
2	1	952 201 ... 0	14	2	EXTENSION CABLE FOR SENSOR
1	1	952 201 ... 0	13	2	EXTENSION CABLE FOR SENSOR
Denomination		Denomination		Denomination	
Product Identification No.		Product Identification No.		Product Identification No.	
Pos./Pcs.		Pos./Pcs.		Pos./Pcs.	
A 3		A 3		A 3	
Pro/E		Pro/E		Pro/E	
E.N. No.		E.N. No.		E.N. No.	
-		-		-	
Revision		Revision		Revision	
-		-		-	
4990		4990		4990	
Agreement for		Agreement for		Agreement for	
-		-		-	
002		002		002	
EN		EN		EN	
1/1		1/1		1/1	
Sheet		Sheet		Sheet	
Date of first issue: 2010-04-27		Date of first issue: 2010-04-27		Date of first issue: 2010-04-27	

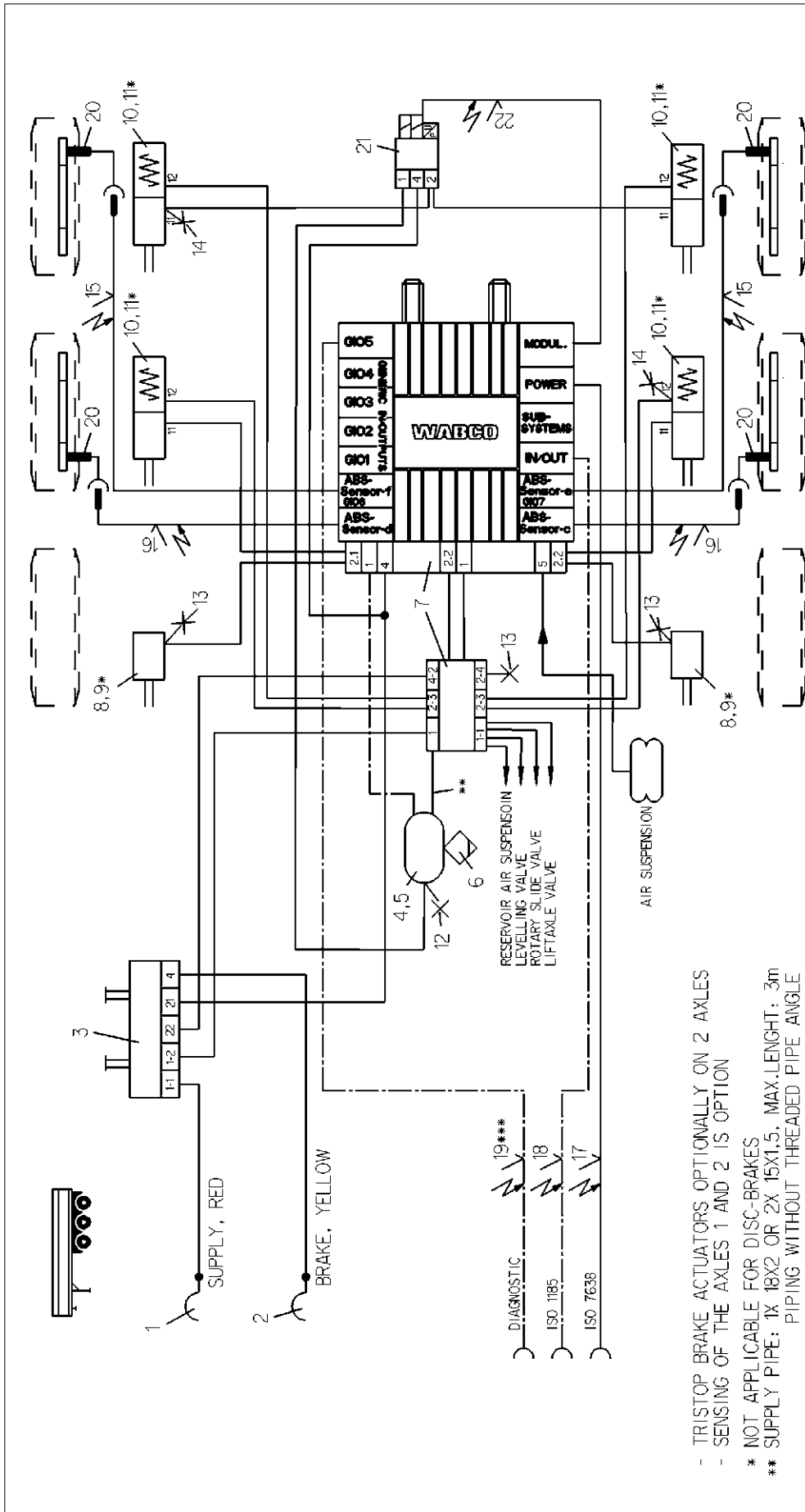

- TRISTOP BRAKE ACTUATORS OPTIONALLY ON 2 AXLES
 - SENSING OF THE AXLES 1 AND 2 IS OPTION
 * NOT APPLICABLE FOR DISC-BRAKES
 ** SUPPLY PIPE: 1X 18X2 OR 2X 15X1,5, MAX.LENGTH: 3m
 PIPING WITHOUT THREADED PIPE ANGLE
 *** OPTIONALLY

Copyright WABCO®		WABCO	
Part No.	Quantity	Part No.	Quantity
463 703 ... 0	1	TRAILER - EBS E	1
423 903 532 2	1	FOR 3-AXLES-SEMI TRAILER	1
925 ... 000 ... 2	1	4S/3M	1
423 000 ... 2	1	Part No.	841 701 232 0
423 10 ... 0	1	Rev. No.	002
480 102 ... 0	1	Rev. Date	EN 1/1
934 300 001 0	1	Rev. Desc.	4990
451 989 ... 2	1	Rev. Part.	
950 ... 000 ... 2	1	Rev. Rep.	
971 002 9 ... 0	1	Rev. Draw.	
952 201 001 0	1	Rev. Test.	
952 201 002 0	1	Rev. Prod.	
Product Identification No.	Pos./Pcs.	Denomination	
463 703 036 0	1	TRAILER IDENTIFICATION NO.	
463 703 020 0	1	TRAILER IDENTIFICATION NO.	
449 429 ... 0	1	CABLE TO EBS-RV	
480 207 001 0	1	EBS-RELAY VALVE	
441 032 6 ... 0	1	ABS-SENSOR	
449 611 ... 0	1	DIAGNOSTIC CABLE	
449 349 ... 0	1	24V-CABLE	
449 173 ... 0	1	SUPPLY (POWER) CABLE	
449 723 ... 0	1	EXTENSION CABLE FOR SENSOR	
449 723 ... 0	1	EXTENSION CABLE FOR SENSOR	
463 703 036 0	1	TEST CONNECTION	
463 703 020 0	1	TEST CONNECTION	

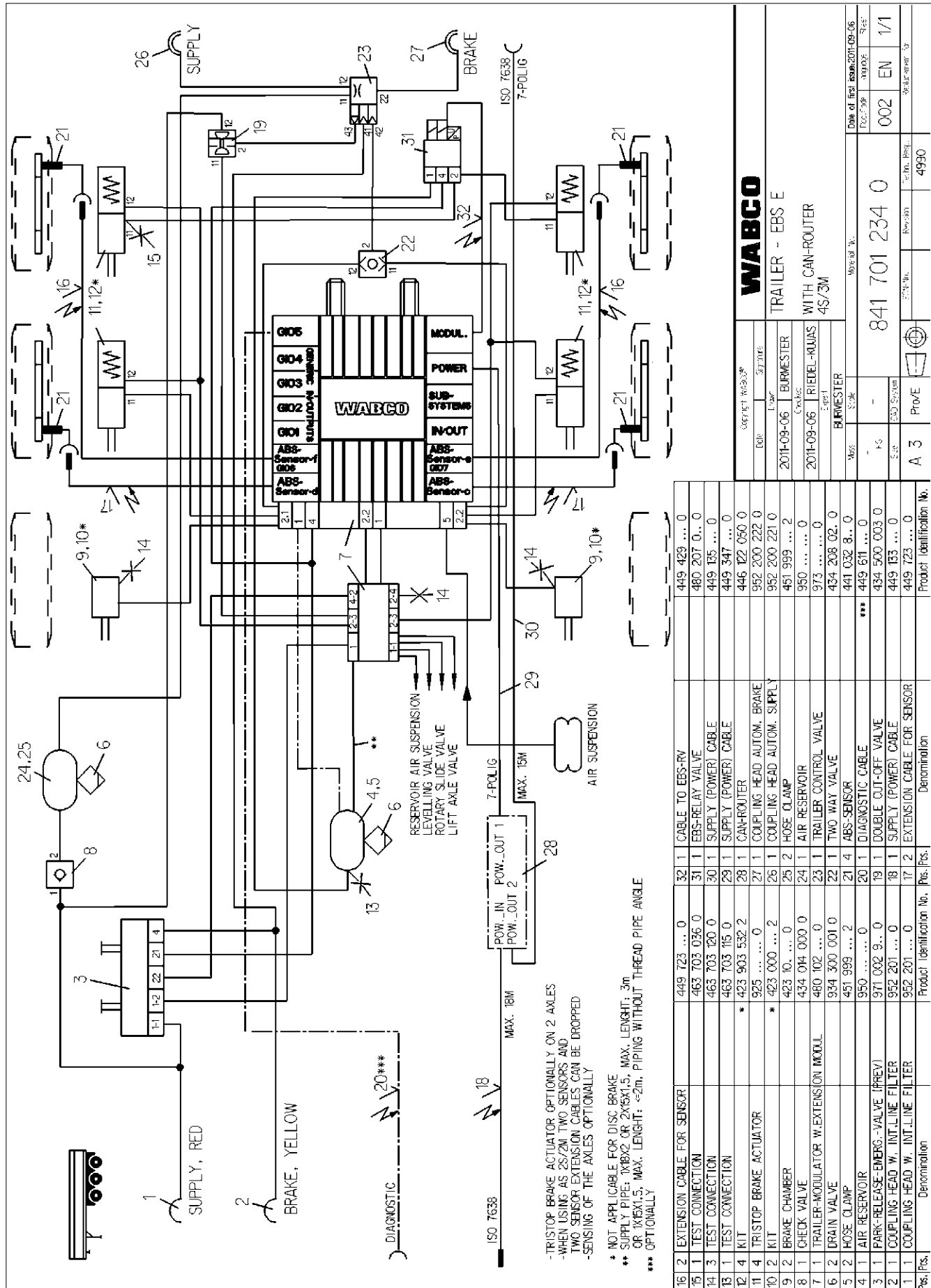

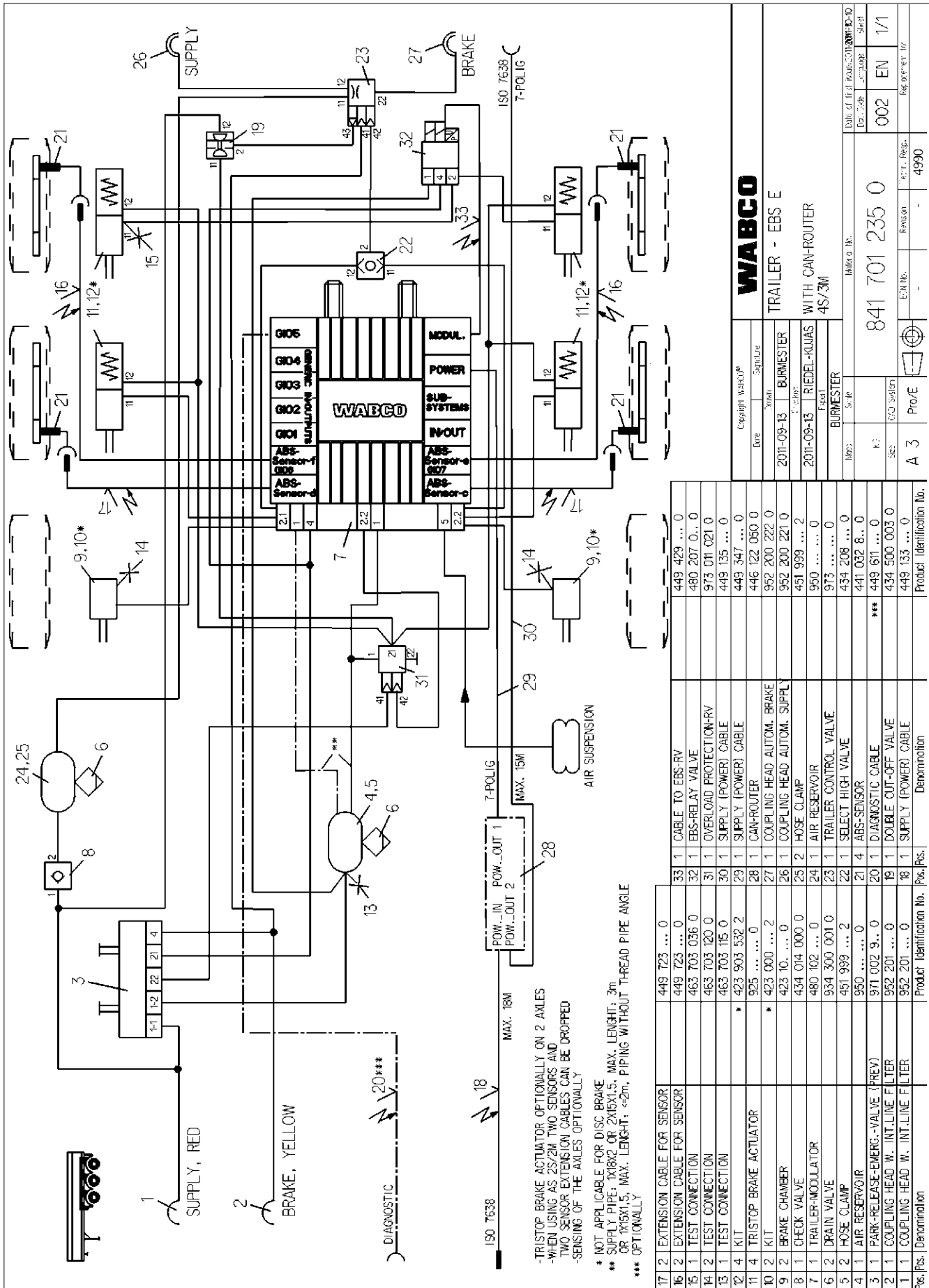

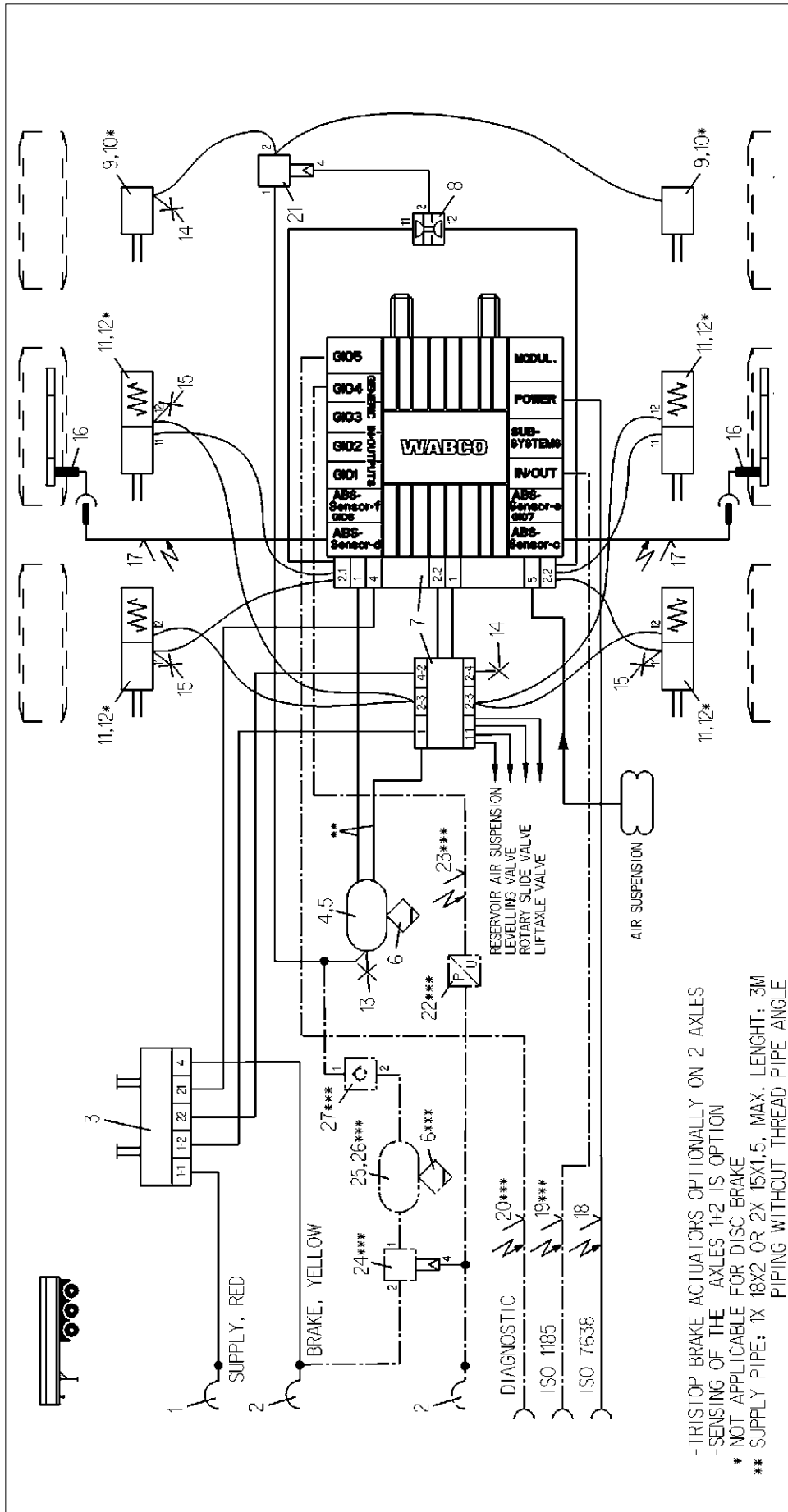

-TRISTOP BRAKE ACTUATORS OPTIONALLY ON 2 AXLES
 -SENSING OF THE AXLES 1+2 IS OPTION
 * NOT APPLICABLE FOR DISC BRAKE
 ** SUPPLY PIPE: 1X 18X2 OR 2X 15X1,5, MAX. LENGTH: 3M
 PIPING WITHOUT THREAD PIPE ANGLE
 *** OPTIONALLY

Pos. / Kit	Description	Product Identification No.	Pos. / Pcs.
27 1	CHECK VALVE	434 014 000 0	***
26 1	HOSE CLAMP	451 999 ... 2	***
25 1	AIR RESERVOIR	950 410 004 0	***
24 1	CABLE TO PRESSURE SENSOR	973 011 000 0	***
23 1	RELAY VALVE	449 812 ... 0	***
22 1	PRESSURE SENSOR	441 044 102 0	***
21 1	RELAY VALVE	973 011 ... 0	***
20 1	DIAGNOSTIC CABLE	449 611 ... 0	***
19 1	24H CABLE	449 349 ... 0	***
18 1	POWER CABLE	449 173 ... 0	***
17 2	EXTENSION CABLE FOR SENSOR	449 723 ... 0	***
16 2	ABS-SENSOR	441 032 8... 0	***
15 3	TEST CONNECTION	463 703 036 0	***
14 2	TEST CONNECTION	463 703 120 0	***
13 1	TEST CONNECTION	463 703 115 0	***

WABCO

TRAILER - EBS E
 FOR 3-AXLES-SEMI TRAILER
 2S/2M

-SELECT LOW-

Job	Signature	Version No.	Date of first issue: 2012-01-09
2012-01-09	BURMESTER		
2012-01-09	CHRONIS		
No. / Title		Part No.	Rev. / Rep.
		841 701 236 0	002 EN 1/1
A 3 Pro/E		4990	

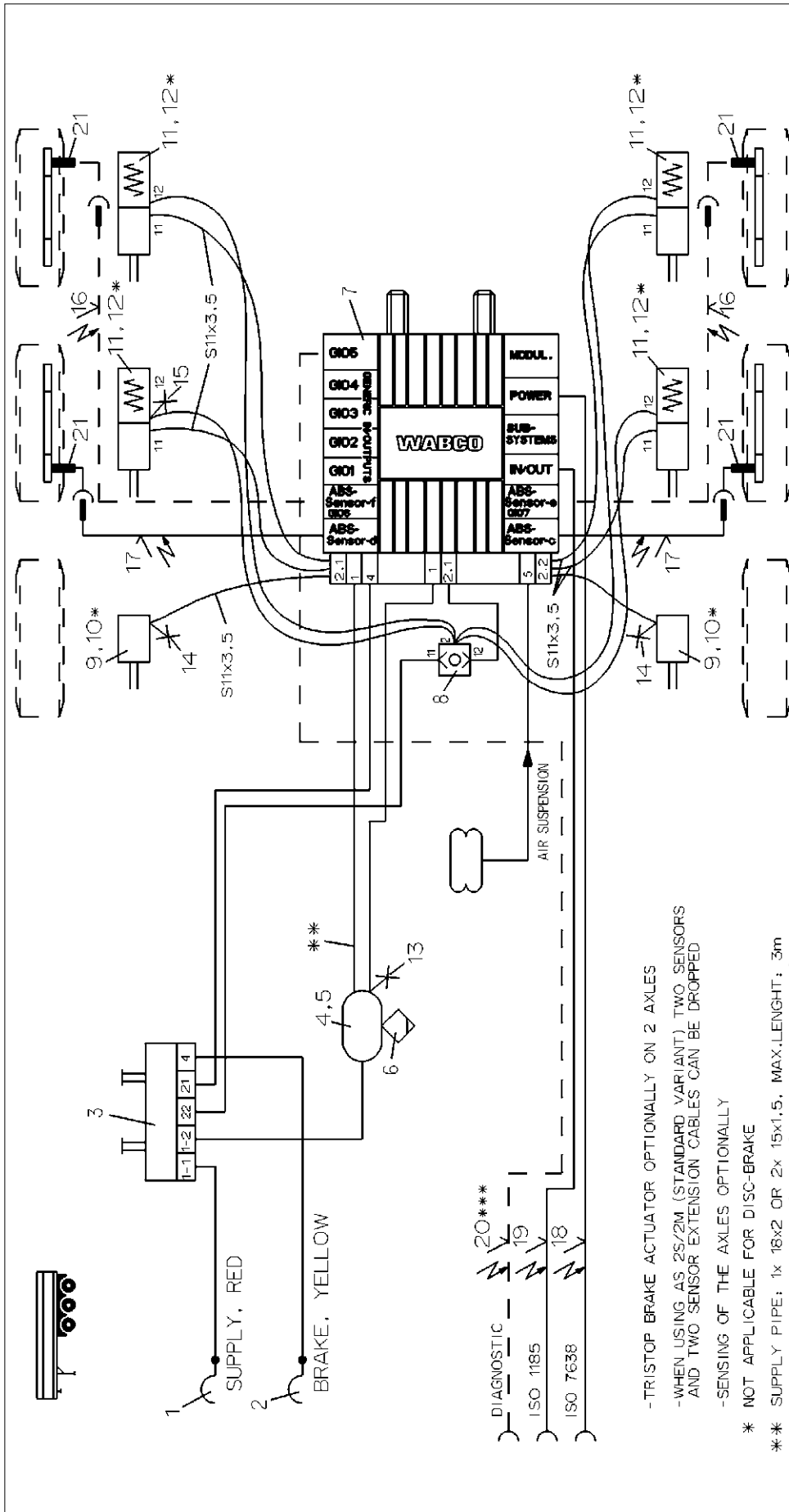

463 703 115 0		463 703 115 0		463 703 115 0		463 703 115 0		463 703 115 0		463 703 115 0		463 703 115 0		463 703 115 0		463 703 115 0		463 703 115 0		463 703 115 0		463 703 115 0	
13	1	TEST CONNECTION																					
12	4	TRISTOP BRAKE ACTUATOR	*	423 903 532 2																			
11	4	TRISTOP BRAKE ACTUATOR	*	925 0																			
10	2	TRISTOP BRAKE ACTUATOR	*	423 000 ... 2																			
9	2	BRAKE CHAMBER		423 10 ... 0																			
8	1	TWO-WAY VALVE		434 208 021 0																			
7	1	TRAILER-MODULATOR		480 102 ... 0																			
6	1	DRAIN VALVE		934 300 001 0																			
5	2	HOSE CLAMP		451 999 ... 0																			
4	1	AIR RESERVOIR		990 0																			
3	1	PARK-RELEASE-EMERGENCY VALVE (PREV)		971 002 9... 0																			
2	1	COUPLING HEAD W.INT.LINE FILTER		952 201 ... 0																			
1	1	COUPLING HEAD W.INT.LINE FILTER		952 201 ... 0																			
Product Identification No.		Denomination		Product Identification No.		Denomination		Product Identification No.		Denomination		Product Identification No.		Denomination		Product Identification No.		Denomination		Product Identification No.		Denomination	
463 703 115 0		TRISTOP BRAKE ACTUATOR		463 703 115 0		TRISTOP BRAKE ACTUATOR		463 703 115 0		TRISTOP BRAKE ACTUATOR		463 703 115 0		TRISTOP BRAKE ACTUATOR		463 703 115 0		TRISTOP BRAKE ACTUATOR		463 703 115 0		TRISTOP BRAKE ACTUATOR	

WABCO
 TRAILER - EBS E
 FOR 3-AXLES-SEMITRAILER
 4S/2M OR 2S/2M

Date of first issue: 2012-04-16
 (Ex. date) | Language | Page

Material No.: 841 701 237 0
 Rev. No.: 002
 En.: EN
 Release date: 1/11

Part: A 3
 Pro/E
 Tech. Resp.: 4990

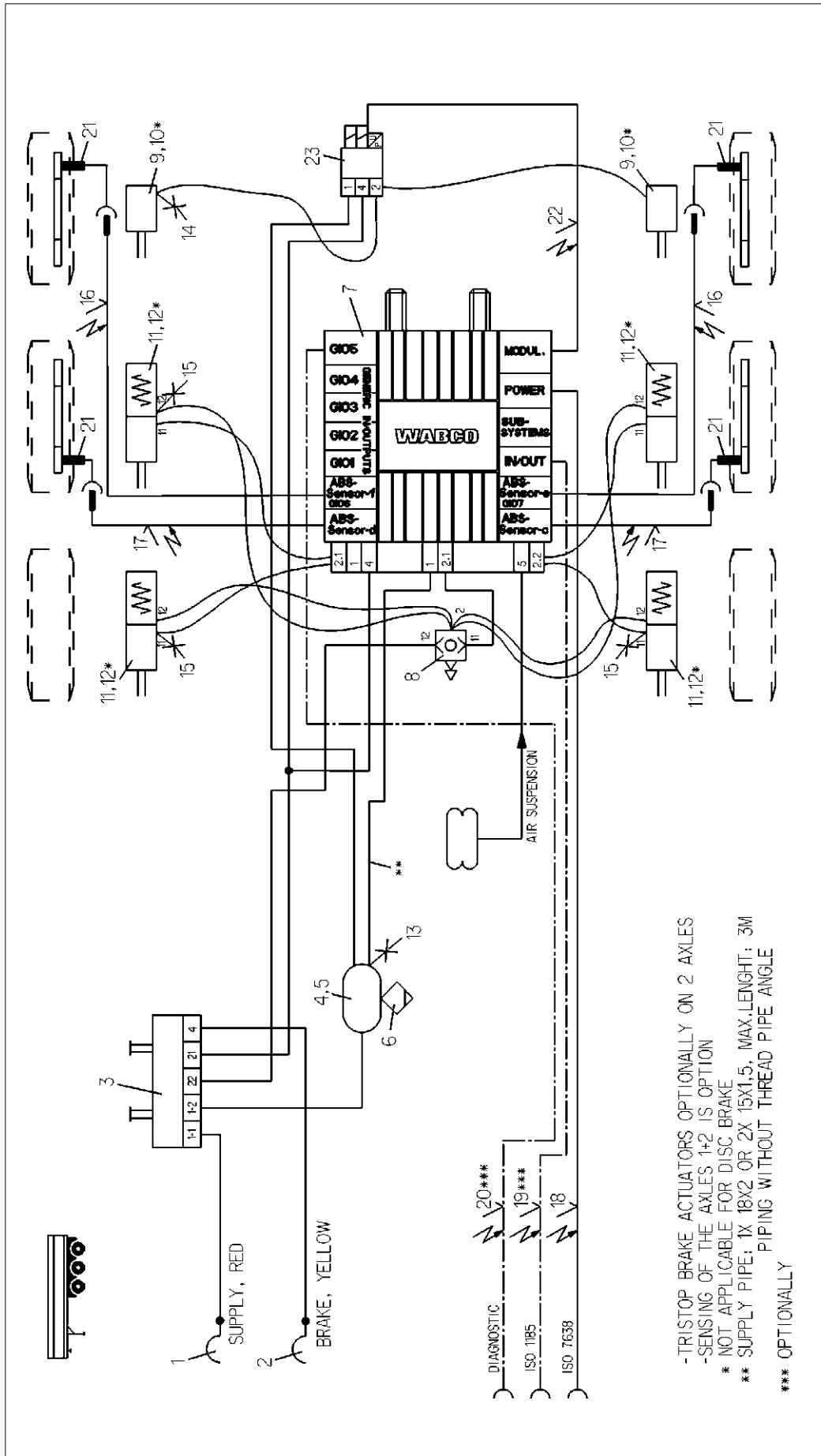

-TRISTOP BRAKE ACTUATORS OPTIONALLY ON 2 AXLES
 -SENSING OF THE AXLES 1+2 IS OPTION
 * NOT APPLICABLE FOR DISC BRAKE
 ** SUPPLY PIPE: 1X 18X2 OR 2X 15X1.5, MAX.LENGTH: 3M
 PIPING WITHOUT THREAD PIPE ANGLE
 *** OPTIONALLY

Part No.		Description		Quantity		Unit	
12	4	423 903 532 2	*	23	1	EBS-RELAY VALVE	
11	4	925 ... 0	*	22	1	CABLE TO EBS-RV	
10	2	423 000 ... 2		21	4	ABS-SENSOR	
9	2	423 10 ... 0		20	1	DIAGNOSTIC CABLE	
8	1	973 500 051 0		19	1	24N-CABLE	
7	1	490 102 ... 0		18	1	POWER (SUPPLY) CABLE	
6	1	934 300 001 0		17	2	EXTENSION CABLE FOR SENSOR	
5	2	451 999 ... 2		16	2	TEST CONNECTION	
4	1	950 ... 0		15	3	TEST CONNECTION	
3	1	971 002 9... 0		14	1	TEST CONNECTION	
2	1	952 201 ... 0		13	1	TEST CONNECTION	
1	1	952 201 ... 0					
Pos./Pcs.	Denomination	Product Identification No.	Pos./Pcs.	Denomination	Product Identification No.		

WABCO		Date of first issue: 2012-05-08	
TRAILER - EBS E		Doc. Code: 4990	
FOR 3-AXLES-SEMI-TRAILER		EN 1/1	
4S/3M		Replacement for	
Burmester		4990	
841 701 238 0		4990	

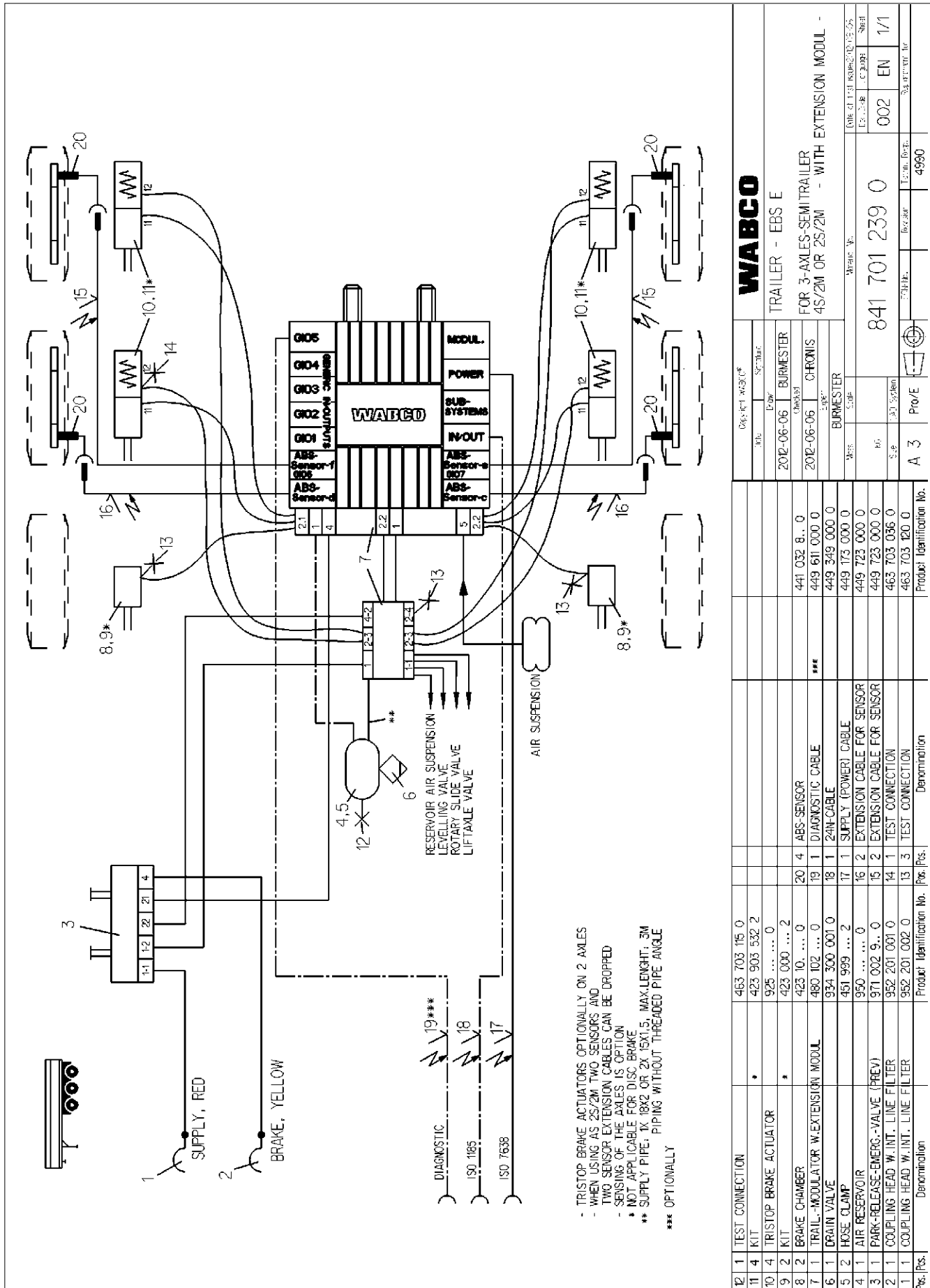

Part No.		Description	
12	1	TEST CONNECTION	463 703 115 0
11	4	KIT	423 903 532 2
10	4	TRISTOP BRAKE ACTUATOR	925 0
9	2	KIT	423 000 ... 2
8	2	BRAKE CHAMBER	423 10 ... 0
7	1	TRAIL-MODULATOR W.EXTENSION MODUL	480 102 ... 0
6	1	DRAIN VALVE	934 300 001 0
5	2	HOSE CLAMP	451 999 ... 2
4	1	AIR RESERVOIR	950 0
3	1	PARK-RELEASE-EMERG.-VALVE (PREV)	971 002 9... 0
2	1	COUPLING HEAD W.INT. LINE FILTER	952 201 001 0
1	1	COUPLING HEAD W.INT. LINE FILTER	952 201 002 0
Pkg./Pcs.	Denomination	Product Identification No.	Pkg./Pcs.
		463 703 120 0	
WABCO TRAILER - EBS E FOR 3-AXLES-SEMI-TRAILER 4S/2M OR 2S/2M - WITH EXTENSION MODUL - BURMESTER Part No. 841 701 239 0 Scale No. of 1st Issues: 002 Date of 1st Issue: 2012-06-06 Ex. Date: 0000 C. Date: EN Seal: 1/1 Form. No.: 4990 Pro/E: A 3			

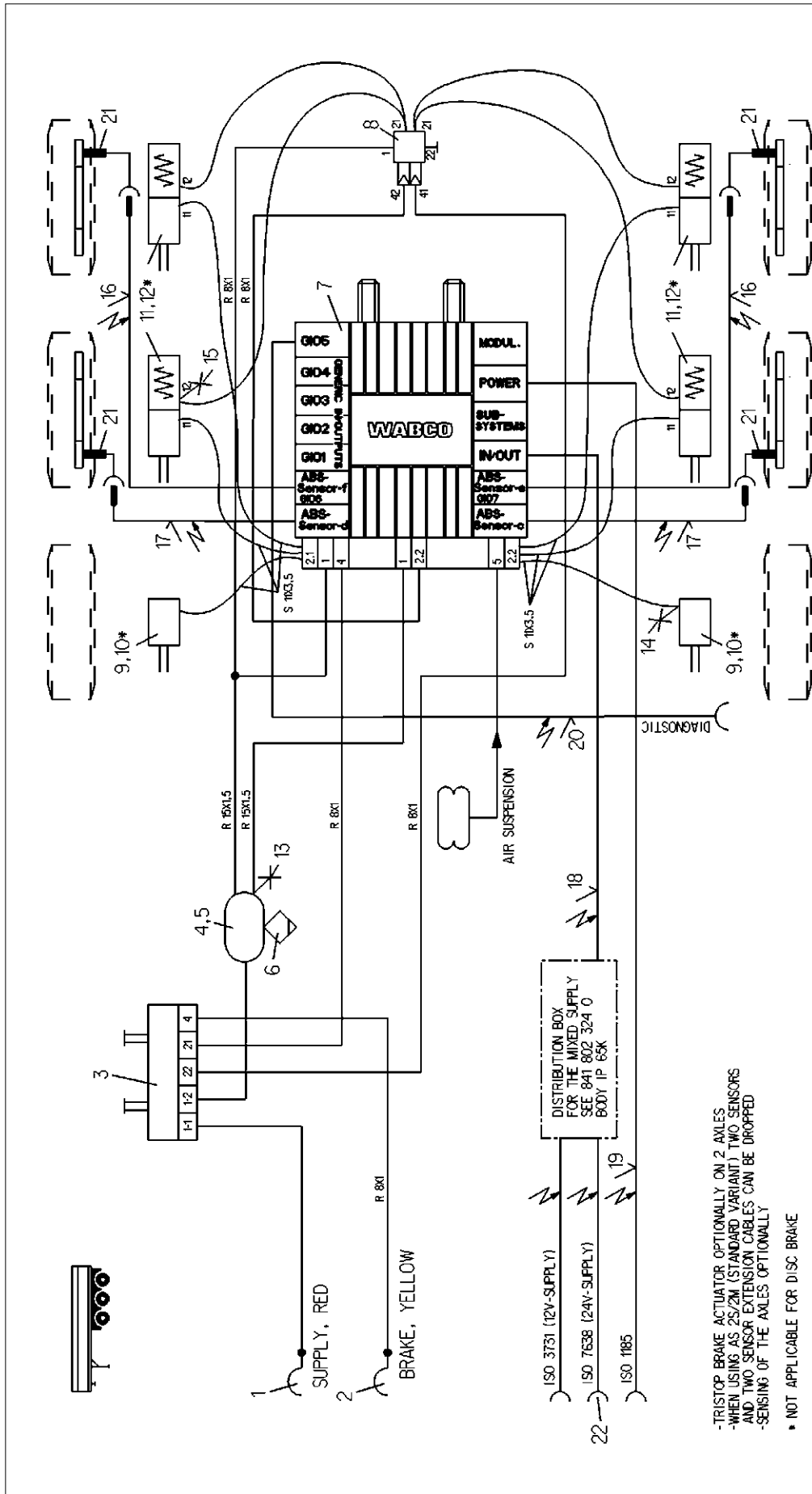

-TRISTOP BRAKE ACTUATOR OPTIONALLY ON 2 AXLES
 -WHEN USING AS 2S/2M (STANDARD VARIANT), TWO SENSORS
 AND TWO SENSOR EXTENSION CABLES CAN BE DROPPED
 -SENSING OF THE AXLES OPTIONALLY

* NOT APPLICABLE FOR DISC BRAKE

Copyright WABCO®		Date	Signature
12	4	423 903 532 2	
11	4	925 0	
10	2	423 000 ... 2	
9	2	423 10 ... 0	
8	1	973 011 021 0	
7	1	480 102 ... 0	
6	1	934 300 001 0	
5	2	451 999 ... 2	
4	1	950 0	
3	1	971 002 9... 0	
2	1	952 201 ... 0	
1	1	952 201 ... 0	
Pos. / Pcs.	Denomination	Product identification No. / Pcs. / Pcs.	Denomination
		423 903 532 2	24
		925 0	23
		423 000 ... 2	22
		423 10 ... 0	21
		973 011 021 0	20
		480 102 ... 0	19
		934 300 001 0	18
		451 999 ... 2	17
		950 0	16
		971 002 9... 0	15
		952 201 ... 0	14
		952 201 ... 0	13
			12
			11
			10
			9
			8
			7
			6
			5
			4
			3
			2
			1
			0
WABCO			
TRAILER - EBS E			
FOR 3-AXLES-SEMITRAILER 4S/2M OR 2S/2M (OVERLOAD-PROTECTION VALVE I (MULTIVOLTAGE)			
Material No.		841 701 260 0	
Date of first issue	2014-01-27	Doc. Code	EN
Language		Version	002
Replacement for		Techn. Resp.	4990
		Part No.	HMR 00481

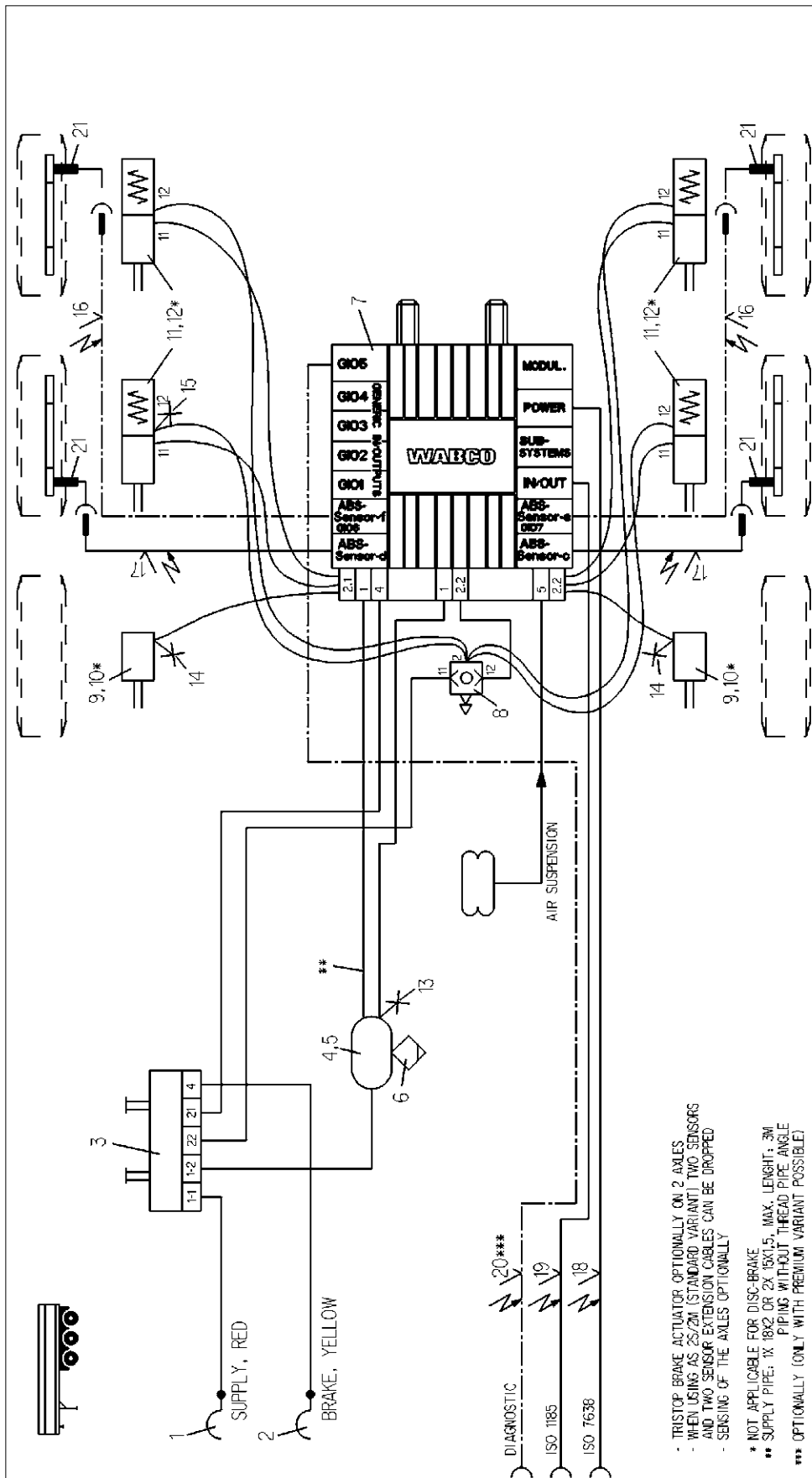

* TRISTOP BRAKE ACTUATOR OPTIONALLY ON 2 AXLES
 - WHEN USING AS 2S/2M (STANDARD VARIANT) TWO SENSORS AND TWO SENSOR EXTENSION CABLES CAN BE DROPPED
 - SENSING OF THE AXLES OPTIONALLY
 ** NOT APPLICABLE FOR DISC-BRAKE
 ** SUPPLY PIPE: 1X 18X2 OR 2X 16X1,5, MAX. LENGTH: 3M
 PIPING WITHOUT THREAD PIPE ANGLE
 *** OPTIONALLY ONLY WITH PREMIUM VARIANT POSSIBLE)



TRAILER - EBS E
 FOR 3-AXLES-SEMITRAILER
 4S/2M OR 2S/2M

Pos./Pcs.	Denomination	Product Identification No.	Pos./Pcs.	Denomination	Product Identification No.
13 1	TEST CONNECTION	463 703 115 0	13 1	TEST CONNECTION	463 703 120 0
12 4	KIT	423 903 532 2	12 4	TRISTOP BRAKE ACTUATOR	925 0
11 4	TRISTOP BRAKE ACTUATOR	925 0	10 2	KIT	423 000 ... 2
10 2	KIT	423 000 ... 2	9 2	BRAKE CHAMBER	423 10 ... 0
9 2	BRAKE CHAMBER	423 10 ... 0	8 1	2-WAY QUICK RELEASE VALVE	973 500 051 0
8 1	2-WAY QUICK RELEASE VALVE	973 500 051 0	7 1	TRAILER-MODULATOR	480 102 ... 0
7 1	TRAILER-MODULATOR	480 102 ... 0	6 1	DRAIN VALVE	934 300 001 0
6 1	DRAIN VALVE	934 300 001 0	5 2	HOSE CLAMP	451 999 ... 0
5 2	HOSE CLAMP	451 999 ... 0	4 1	AIR RESERVOIR	950 0
4 1	AIR RESERVOIR	950 0	3 1	PARK-RELEASE-EMERGENCY VALVE (PREV)	971 002 9... 0
3 1	PARK-RELEASE-EMERGENCY VALVE (PREV)	971 002 9... 0	2 1	COUPLING HEAD W. INT. LINE FILTER	952 201 ... 0
2 1	COUPLING HEAD W. INT. LINE FILTER	952 201 ... 0	1 1	COUPLING HEAD W. INT. LINE FILTER	952 201 ... 0
1 1	COUPLING HEAD W. INT. LINE FILTER	952 201 ... 0			

WABCO					
TRAILER - EBS E					
FOR 3-AXLES-SEMITRAILER					
4S/2M OR 2S/2M					
Order ref. WABCO	Date	Version	Material No.	ECV No.	Year/1
2012-07-10	BURNESTER	1	841 701 261 0	4990	002 EN 1/1
2012-07-10	CHRONIS	1			
2012-07-10	BURNESTER	1			
441 032 8... 0	AFS-SENSOR	21	4		
449 611 ... 0	DIAGNOSTIC CABLE	20	1		
449 349 ... 0	24IN-CABLE	19	1		
449 173 ... 0	SUPPLY (POWER) CABLE	18	1		
449 723 ... 0	EXTENSION CABLE FOR SENSOR	17	2		
449 723 ... 0	EXTENSION CABLE FOR SENSOR	16	2		
463 703 036 0	TEST CONNECTION	15	1		
463 703 120 0	TEST CONNECTION	14	2		

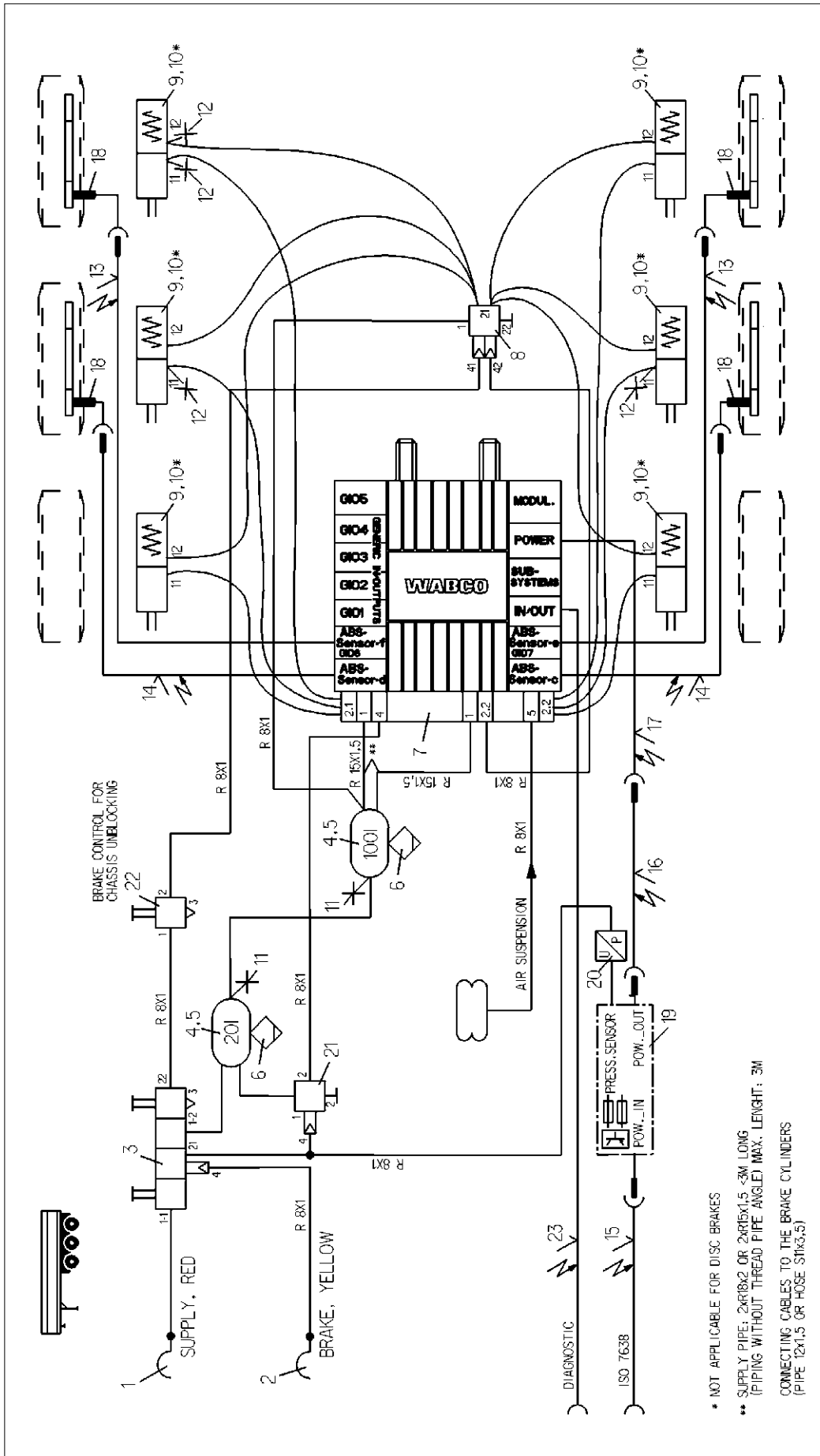

Part No.		Description		QTY	
12	463 703 036 0	24	CABLE IN/OUT	449 349 ... 0	
11	463 703 ... 0	23	RELEASE VALVE	963 006 005 0	
10	423 903 532 2	22	RELAY VALVE	973 011 000 0	
9	925 ... 0	21	PRESSURE SENSOR	446 044 102 0	
8	973 011 201 0	20	EBS-CAN-REPEATER	446 122 055 0	
7	480 102 06. 0	19	ABS-SENSOR	441 032 ... 0	
6	934 300 001 0	18	BAJ-CABLE W. ECU-PLUG SOCKET	449 347 003 0	
5	451 999 ... 2	17	V-CABLE-EXTENSION DIN-BAJ-40JM	894 600 032 0	
4	950 ... 0	16	V-CABLE WITH PLUS SOCKET	449 135 0... 0	
3	971 002 9... 0	15	EXTENSION CABLE	449 723 ... 0	
2	952 201 001 0	14	EXTENSION CABLE	449 723 ... 0	
1	952 201 002 0	13	EXTENSION CABLE	449 723 ... 0	

12	463 703 036 0	24	CABLE IN/OUT	449 349 ... 0	
11	463 703 ... 0	23	RELEASE VALVE	963 006 005 0	
10	423 903 532 2	22	RELAY VALVE	973 011 000 0	
9	925 ... 0	21	PRESSURE SENSOR	446 044 102 0	
8	973 011 201 0	20	EBS-CAN-REPEATER	446 122 055 0	
7	480 102 06. 0	19	ABS-SENSOR	441 032 ... 0	
6	934 300 001 0	18	BAJ-CABLE W. ECU-PLUG SOCKET	449 347 003 0	
5	451 999 ... 2	17	V-CABLE-EXTENSION DIN-BAJ-40JM	894 600 032 0	
4	950 ... 0	16	V-CABLE WITH PLUS SOCKET	449 135 0... 0	
3	971 002 9... 0	15	EXTENSION CABLE	449 723 ... 0	
2	952 201 001 0	14	EXTENSION CABLE	449 723 ... 0	
1	952 201 002 0	13	EXTENSION CABLE	449 723 ... 0	

12	463 703 036 0	24	CABLE IN/OUT	449 349 ... 0	
11	463 703 ... 0	23	RELEASE VALVE	963 006 005 0	
10	423 903 532 2	22	RELAY VALVE	973 011 000 0	
9	925 ... 0	21	PRESSURE SENSOR	446 044 102 0	
8	973 011 201 0	20	EBS-CAN-REPEATER	446 122 055 0	
7	480 102 06. 0	19	ABS-SENSOR	441 032 ... 0	
6	934 300 001 0	18	BAJ-CABLE W. ECU-PLUG SOCKET	449 347 003 0	
5	451 999 ... 2	17	V-CABLE-EXTENSION DIN-BAJ-40JM	894 600 032 0	
4	950 ... 0	16	V-CABLE WITH PLUS SOCKET	449 135 0... 0	
3	971 002 9... 0	15	EXTENSION CABLE	449 723 ... 0	
2	952 201 001 0	14	EXTENSION CABLE	449 723 ... 0	
1	952 201 002 0	13	EXTENSION CABLE	449 723 ... 0	

12	463 703 036 0	24	CABLE IN/OUT	449 349 ... 0	
11	463 703 ... 0	23	RELEASE VALVE	963 006 005 0	
10	423 903 532 2	22	RELAY VALVE	973 011 000 0	
9	925 ... 0	21	PRESSURE SENSOR	446 044 102 0	
8	973 011 201 0	20	EBS-CAN-REPEATER	446 122 055 0	
7	480 102 06. 0	19	ABS-SENSOR	441 032 ... 0	
6	934 300 001 0	18	BAJ-CABLE W. ECU-PLUG SOCKET	449 347 003 0	
5	451 999 ... 2	17	V-CABLE-EXTENSION DIN-BAJ-40JM	894 600 032 0	
4	950 ... 0	16	V-CABLE WITH PLUS SOCKET	449 135 0... 0	
3	971 002 9... 0	15	EXTENSION CABLE	449 723 ... 0	
2	952 201 001 0	14	EXTENSION CABLE	449 723 ... 0	
1	952 201 002 0	13	EXTENSION CABLE	449 723 ... 0	

* NOT APPLICABLE FOR DISC BRAKES

** SUPPLY PIPE, 2xR18x2 OR 2xR15x1.5 <3M LONG (PIPING WITHOUT THREAD PIPE ANGLE) MAX. LENGTH: 3M

CONNECTING CABLES TO THE BRAKE CYLINDERS (PIPE 12x1.5 OR HOSE 51x3.5)

WABCO

TRAILER - EBS E
3-AXLES-SEMITRAILER EXTENDABLE,
CAN-REPEATER, RELAY VALVE AND PRESS.SENSOR
IN THE BRAKE HOSE

Part No. 841 701 263 0

Date of first issue: 2019-03-06

Rev. Code: 1

Page: 002 EN 1/1

Revision: HWR 00459

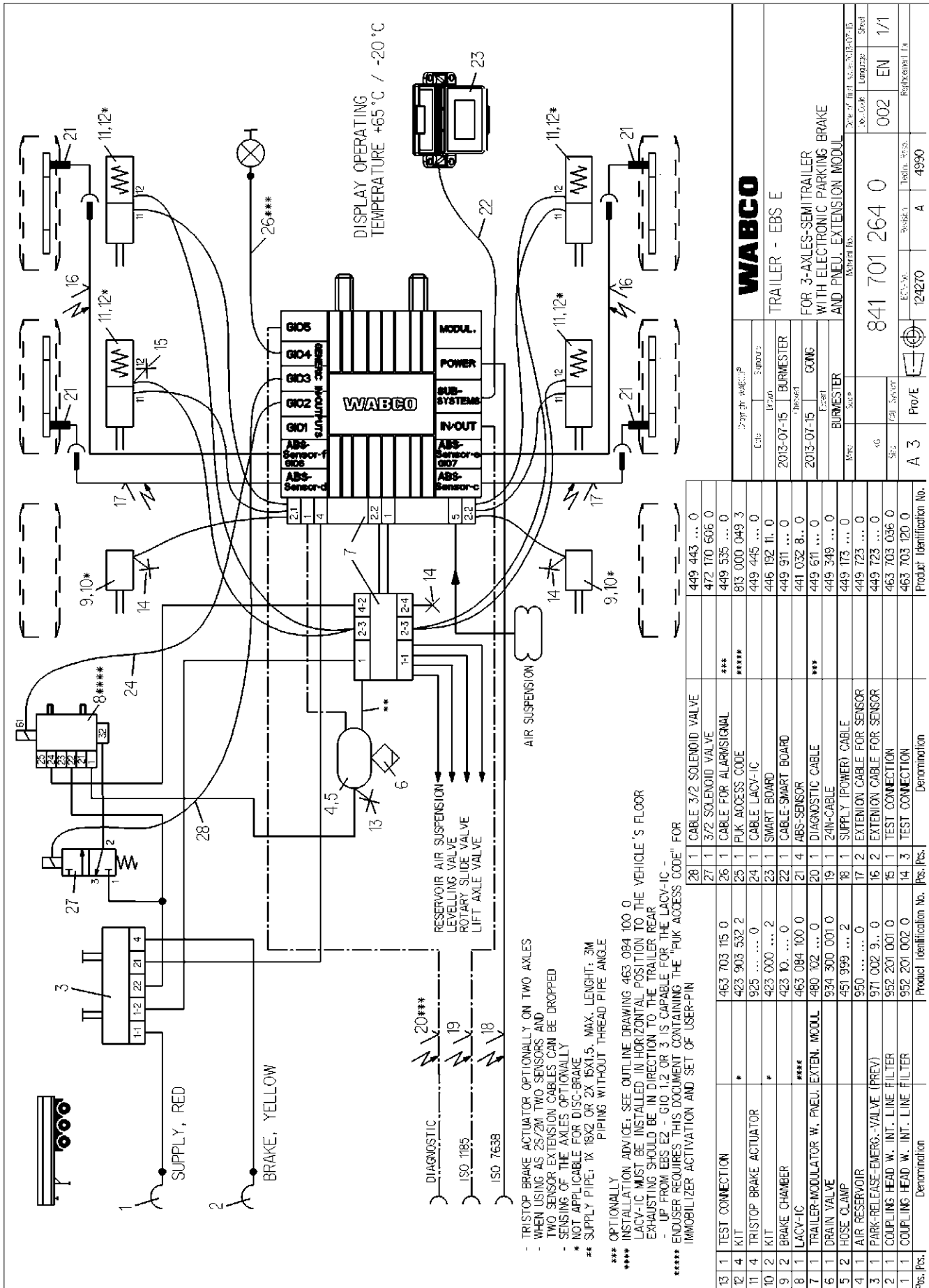

- TRISTOP BRAKE ACTUATOR OPTIONALLY ON TWO AXLES
- WHEN USING AS 2S/2M TWO SENSORS AND TWO SENSOR EXTENSION CABLES CAN BE DROPPED
- SENSING OF THE AXLES OPTIONALLY
- * NOT APPLICABLE FOR DISC-BRAKE
- ** SUPPLY PIPE: 1X 18X2 OR 2X 15X1.5, MAX. LENGTH: 3M PIPING WITHOUT THREAD PIPE ANGLE
- *** OPTIONALLY
- **** INSTALLATION ADVICE: SEE OUTLINE DRAWING 463 084 100 0 LACV-IC MUST BE INSTALLED IN HORIZONTAL POSITION TO THE VEHICLE'S FLOOR EXHAUSTING SHOULD BE IN DIRECTION TO THE TRAILER REAR
- UP FROM EBS E2 - GIO 12 OR 3 IS CAPABLE FOR THE LACV-IC - ENDUSER REQUIRES THIS DOCUMENT CONTAINING THE 'PUK ACCESS CODE' FOR IMMOBILIZER ACTIVATION AND SET OF USER-PIN

Pos./Pos.	Denomination	Product Identification No.	Pos./Pos.	Denomination	Product Identification No.
13 1	TEST CONNECTION	463 703 115 0	28 1	CABLE 3/2 SOLENOID VALVE	449 443 ... 0
12 4	KIT	423 903 532 2	27 1	3/2 SOLENOID VALVE	472 170 606 0
11 4	TRISTOP BRAKE ACTUATOR	925 0	26 1	CABLE FOR ALARMSIGNAL	449 535 ... 0
10 2	KIT	423 000 ... 2	25 1	PUK ACCESS CODE	813 000 049 3
9 2	BRAKE CHAMBER	423 10 ... 0	24 1	CABLE LACV-IC	449 445 ... 0
8 1	LACV-IC	463 084 100 0	23 1	SMART BOARD	446 192 11 0
7 1	TRAILER-MODULATOR W. PNEU. EXTEN. MODULE	480 102 ... 0	22 1	CABLE-SMART BOARD	449 911 ... 0
6 1	DRAIN VALVE	934 300 001 0	21 4	ABS-SENSOR	441 032 8... 0
5 2	HOSE CLAMP	451 999 ... 2	20 1	DIAGNOSTIC CABLE	449 611 ... 0
4 1	AIR RESERVOIR	950 0	19 1	24IN-CABLE	449 349 ... 0
3 1	PARK-RELEASE-EMERG.-VALVE (PREV)	971 002 9... 0	18 1	SUPPLY (POWER) CABLE	449 173 ... 0
2 1	COUPLING HEAD W. INT. LINE FILTER	952 201 001 0	17 2	EXTENSION CABLE FOR SENSOR	449 723 ... 0
1 1	COUPLING HEAD W. INT. LINE FILTER	952 201 002 0	16 2	EXTENSION CABLE FOR SENSOR	449 723 ... 0
			15 1	TEST CONNECTION	463 703 086 0
			14 3	TEST CONNECTION	463 703 120 0

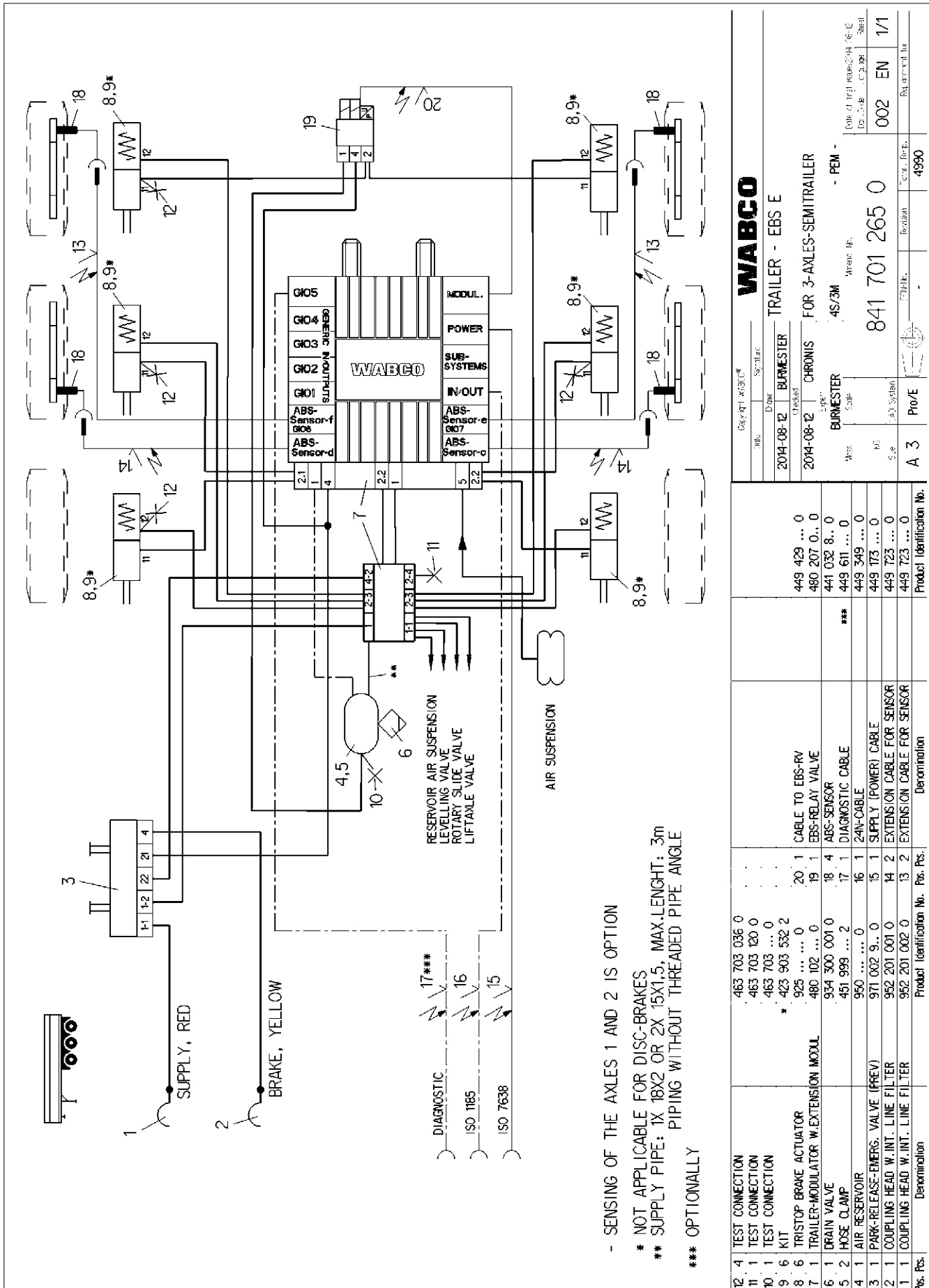

- SENSING OF THE AXLES 1 AND 2 IS OPTION

* NOT APPLICABLE FOR DISC-BRAKES

** SUPPLY PIPE: 1X 18X2 OR 2X 15X1,5, MAX-LENGTH: 3m
PIPING WITHOUT THREADED PIPE ANGLE

*** OPTIONALLY

Part No.	Description	Product Identification No.	Denomination	Pos. No.
12 4	TEST CONNECTION	463 703 036 0		
11 1	TEST CONNECTION	463 703 120 0		
10 1	TEST CONNECTION	463 703 ... 0		
9 6	KIT	* 423 903 532 2		
8 6	TRISTOP BRAKE ACTUATOR	925 0	20 1	
7 1	TRAILER-MODULATOR W.EXTENSION MODUL	480 102 ... 0	19 1	
6 1	DRAIN VALVE	934 300 001 0	18 4	
5 2	HOSE CLAMP	451 999 ... 2	17 1	
4 1	AIR RESERVOIR	950 0	16 1	
3 1	PARK-RELEASE-EMERG. VALVE (PREV)	971 002 9... 0	15 1	
2 1	COUPLING HEAD W. INT. LINE FILTER	952 201 001 0	14 2	
1 1	COUPLING HEAD W. INT. LINE FILTER	952 201 002 0	13 2	
Pos. No.	Denomination	Product Identification No.	Pos. No.	
A 3	Pro/E	449 429 ... 0		
		480 207 0... 0		
		441 032 8... 0		
		449 611 ... 0		
		449 349 ... 0		
		449 723 ... 0		
		449 723 ... 0		
		Product Identification No.		
		4990		

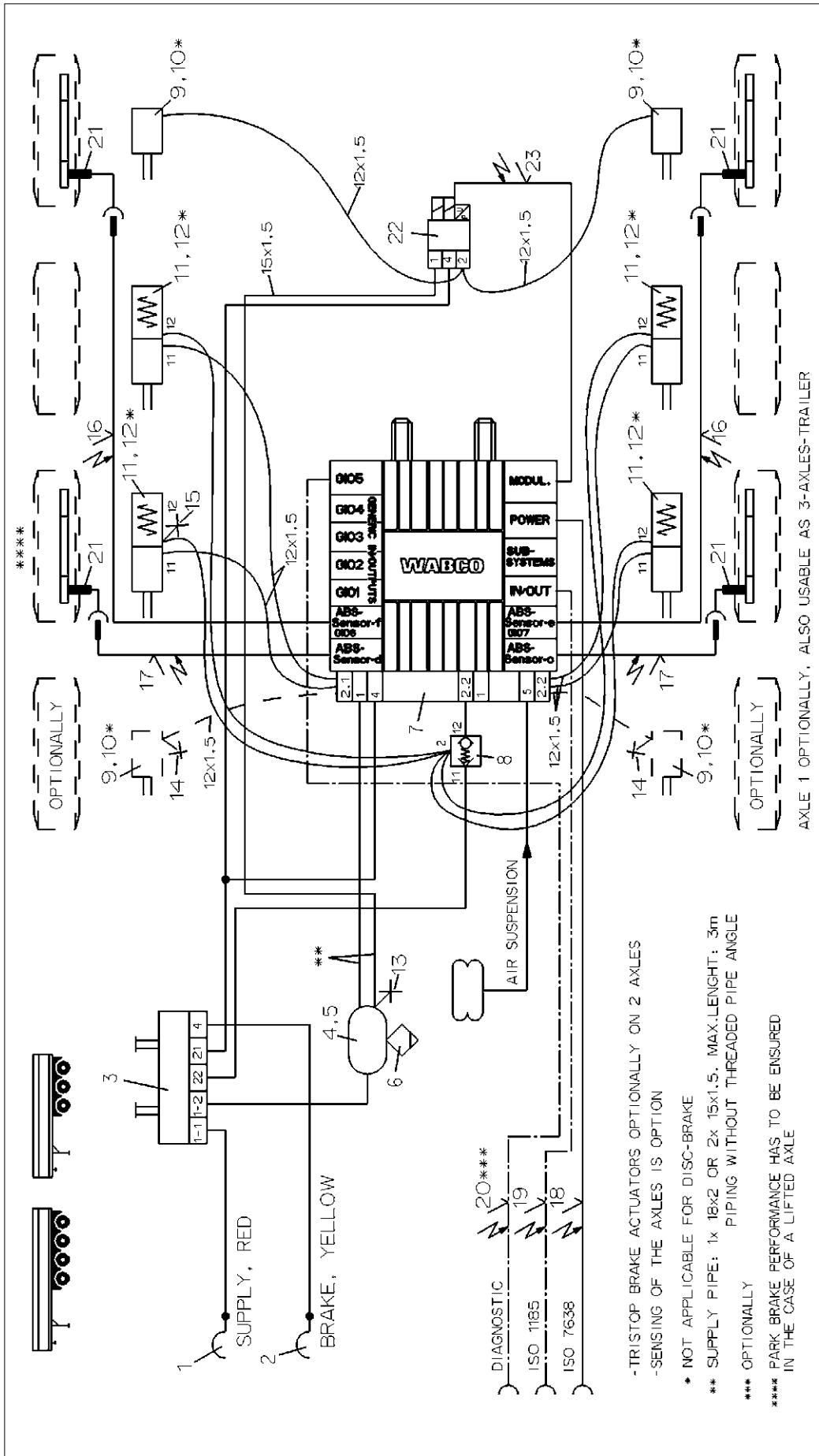

Pos./Pcs.	Denomination	Product Identification No.	Pcs.	Denomination	Copyright wabco®		Date	E-part	E-part	WABCO
					Part	Sheet				
12 4	KIT	423 903 532 2			449 429 000 0		06-12-04	APITHY		TRAILER - EBS E
11 4	TRISTOP BRAKE ACTUATOR	925 ... 0	23 1	CABLE TO EBS-RV	480 207 001 0		06-12-04	GROSSK.		FOR 3- AND 4-AXLES-SEMI TRAILER 4S/3M
10 4	KIT	423 000 ... 2	22 1	EBS-RELAY VALVE	441 032 8... 0					
9 4	BRAKE CHAMBER	423 10... 0	21 4	ABS-SENSOR	449 611 000 0	***				
8 1	TWO-WAY-VALVE	434 208 055 0	20 1	DIAGNOSTIC CABLE	449 349 000 0					
7 1	TRAILER-MODULATOR	480 102 ... 0	19 1	24N-CABLE	449 173 000 0					
6 1	DRAIN VALVE	934 300 001 0	18 1	SUPPLY (POWER) CABLE	449 723 000 0					
5 2	HOSE CLAMP	451 999 ... 2	17 2	EXTENSION CABLE FOR SENSOR	463 703 035 0					
4 1	AIR RESERVOIR	950 ... 0	16 2	EXTENSION CABLE FOR SENSOR	463 703 120 0					
3 1	PARK-RELEASE-EMERG.-VALVE (PREV)	971 002 9... 0	15 1	TEST CONNECTION	463 703 ... 0					
2 1	COUPLING HEAD W.INT. LINE FILTER	952 201 001 0	14 2	TEST CONNECTION						
1 1	COUPLING HEAD W.INT. LINE FILTER	952 201 002 0	13 1	TEST CONNECTION						
Pos./Pcs.	Denomination	Product Identification No.	Pcs.	Denomination						

AXLE 1 OPTIONALLY, ALSO USABLE AS 3-AXLES-TRAILER

-TRISTOP BRAKE ACTUATORS OPTIONALLY ON 2 AXLES
-SENSING OF THE AXLES IS OPTION

* NOT APPLICABLE FOR DISC-BRAKE

** SUPPLY PIPE: 1x 18x2 OR 2x 15x1.5. MAX.LENGTH: 3m
PIPING WITHOUT THREADED PIPE ANGLE

*** OPTIONALLY

**** PARK BRAKE PERFORMANCE HAS TO BE ENSURED
IN THE CASE OF A LIFTED AXLE

Ex. No.	002	Rev. No.	B
Rev. No.	EN	Rev. No.	4990
Rev. No.	1/1	Rev. No.	123543
Rev. No.	002	Rev. No.	4990

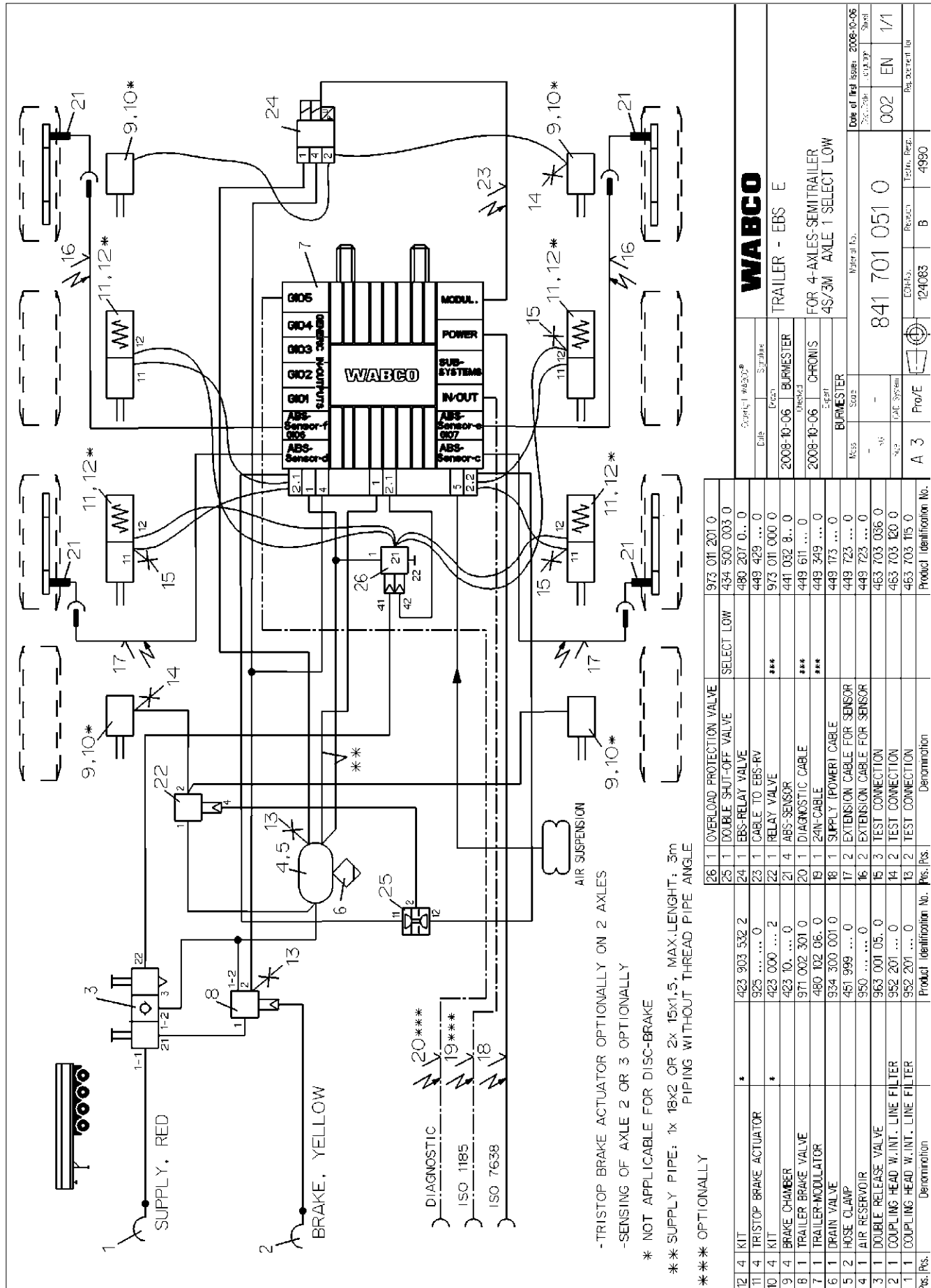

Pos./Pcs.	Denomination	Product Identification No.	Pcs./Pcs.	Denomination	Product Identification No.
12 4	KIT	973 011 201 0	1	OVERLOAD PROTECTION VALVE	973 011 201 0
11 4	TRISTOP BRAKE ACTUATOR	434 500 003 0	1	DOUBLE SHUT-OFF VALVE	434 500 003 0
10 4	KIT	480 207 0... 0	1	EBS-RELAY VALVE	480 207 0... 0
9 4	BRAKE CHAMBER	449 429 ... 0	1	CABLE TO EBS-RV	449 429 ... 0
8 1	TRAILER BRAKE VALVE	973 011 000 0	1	RELAY VALVE	973 011 000 0
7 1	TRAILER-MODULATOR	441 032 8... 0	1	ABS-SENSOR	441 032 8... 0
6 1	DRAIN VALVE	449 611 ... 0	1	DIAGNOSTIC CABLE	449 611 ... 0
5 2	HOSE CLAMP	449 349 ... 0	1	TRAILER 24IN-CABLE	449 349 ... 0
4 1	AIR RESERVOIR	449 173 ... 0	1	SUPPLY (POWER) CABLE	449 173 ... 0
3 1	DOUBLE RELEASE VALVE	449 723 ... 0	1	EXTENSION CABLE FOR SENSOR	449 723 ... 0
2 1	COUPLING HEAD W.INT. LINE FILTER	463 703 036 0	1	EXTENSION CABLE FOR SENSOR	463 703 036 0
1 1	COUPLING HEAD W.INT. LINE FILTER	463 703 120 0	1	TEST CONNECTION	463 703 120 0
		463 703 115 0	1	TEST CONNECTION	463 703 115 0

WABCO
TRAILER - EBS E
 FOR 4-AXLES-SEMITRAILER
 4S/3M AXLE 1 SELECT LOW

Major Ref. No. **841 701 051 0**
 Date of first issue: 2006-10-06
 Revision: **B**
 Tech. Rep.: **4990**

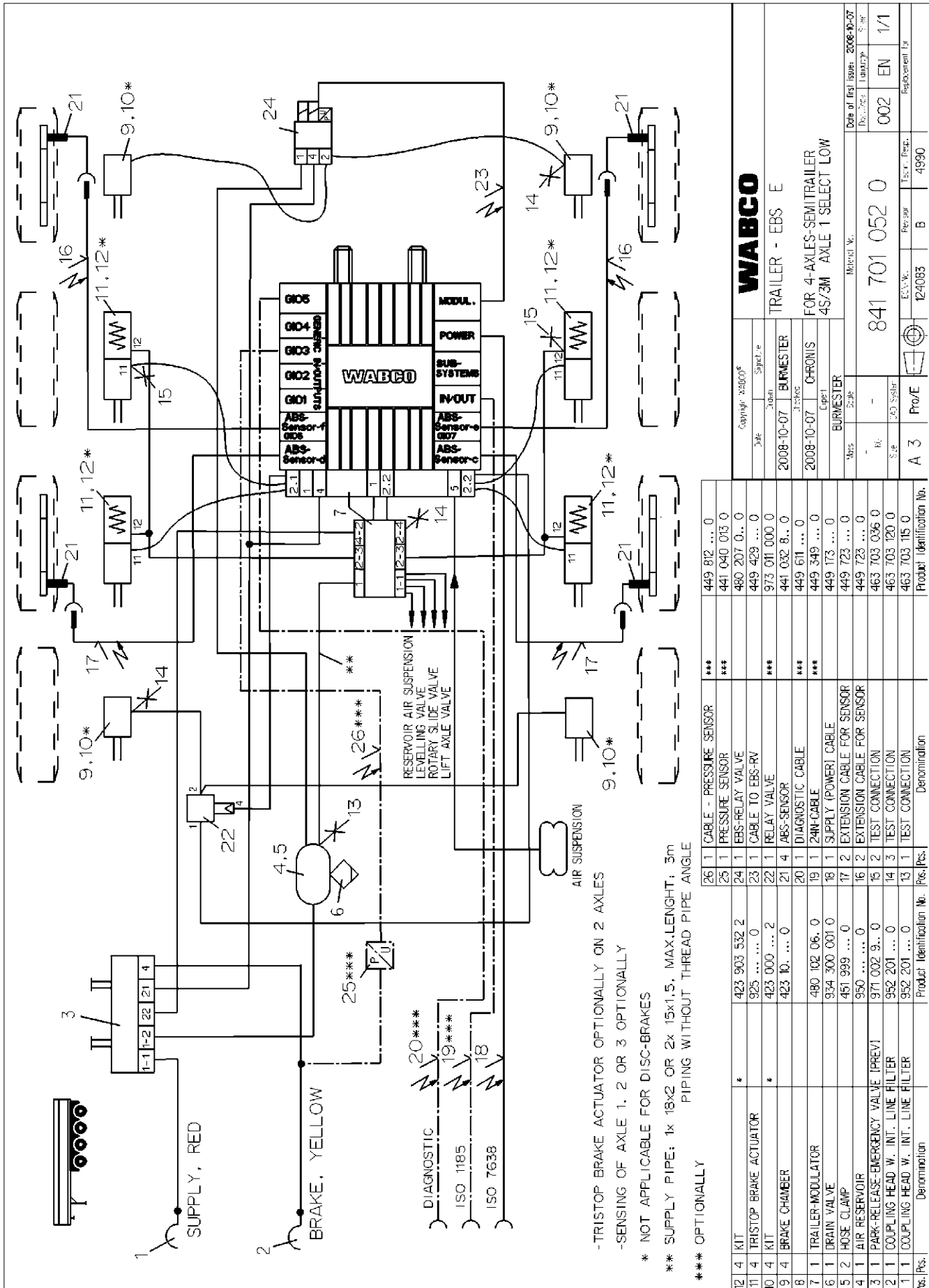

12	4	KIT	*	423 903 532 2	449 812 ... 0	Product Identification No.
11	4	TRISTOP BRAKE ACTUATOR		925 ... 0	441 040 013 0	
10	4	KIT	*	423 000 ... 2	490 207 0... 0	
9	4	BRAKE CHAMBER		423 10... 0	449 429 ... 0	
8					973 011 000 0	
7	1	TRAILER-MODULATOR			441 032 8... 0	
6	1	DRAIN VALVE			449 611 ... 0	
5	2	HOSE CLAMP			449 349 ... 0	
4	1	AIR RESERVOIR			449 723 ... 0	
3	1	PARK-RELEASE-EMERGENCY VALVE (PREV)			449 723 ... 0	
2	1	COUPLING HEAD W. INT. LINE FILTER			463 703 036 0	
1	1	COUPLING HEAD W. INT. LINE FILTER			463 703 120 0	
Pos./Res.		Denomination		Product Identification No.	Pos./Res.	Denomination

Copyright: WABCO®		Date		Sheet		Signature	
2008-10-07		BURMESTER		2008-10-07		CHRONIS	
Material No.		Scale		Case1		Date of first issue: 2006-10-07	
841 701 052 0		-		-		Rev. No. / Unit type / Size	
A 3		Pro/E		B		002 EN 1/1	
124083		4990				Replacement for	

841 701 053 0

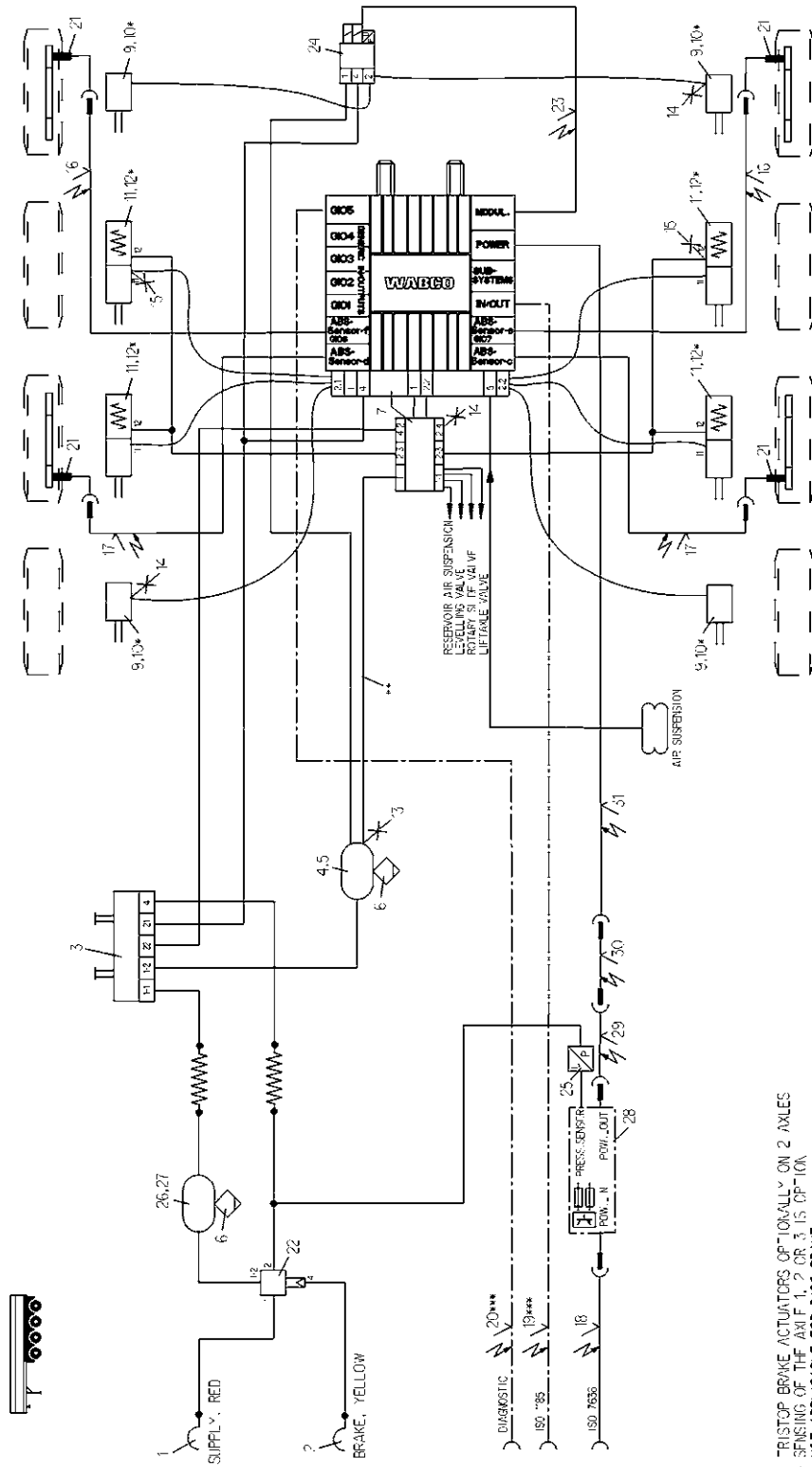

- TRISTOP BRAKE ACTUATORS OPTIONAL ON 2 AXLES
 - SENSING OF THE AXLE 1, 2 OR 3 IS OPTIONAL
 * NOT APPLICABLE FOR DISC BRAKE
 ** SUPPLY PIPE: IX 16X2 OR 2X 16X1.5 MAX. FNHG: 3M
 PIPING WITHOUT THREAD PIPE ANGI F
 *** OPTIONALLY

KIT		WABCO		TRAILER - EBS E	
TRISTOP BRAKE ACTUATOR		200-11-29 BURMESTER		200-11-29 BURMESTER	
KIT		200-11-29 BURMESTER		200-11-29 BURMESTER	
KIT		200-11-29 BURMESTER		200-11-29 BURMESTER	
1	TRISTOP BRAKE ACTUATOR	423 903 532 2	24 1 EBS-RELAY VALVE	480 207 0... 0	Product Identification No.
1	TRISTOP BRAKE ACTUATOR	505 ... 0	23 1 CABLE TO EBS-RELAY VALVE	449 428 ... 0	Denomination
1	TRISTOP BRAKE ACTUATOR	123 000 ... 2	22 1 RELAY EMERGENCY VALVE	511 002 301 0	Part No.
1	TRISTOP BRAKE ACTUATOR	423 10... 0	21 4 ABS-SENSOR	441 032 B... 0	Part No.
1	TRISTOP BRAKE ACTUATOR	423 10... 0	20 1 ABS-SENSOR	449 811 ... 0	Part No.
1	TRISTOP BRAKE ACTUATOR	480 107 06... 0	19 1 24V CARF	449 349 ... 0	Part No.
1	TRISTOP BRAKE ACTUATOR	934 590 001 0	18 1 24V CARF	449 349 ... 0	Part No.
1	TRISTOP BRAKE ACTUATOR	451 595 ... 2	17 1 EXTENSION CABLE FOR SENSOR	449 172 ... 0	Part No.
1	TRISTOP BRAKE ACTUATOR	980 ... 0	16 2 EXTENSION CABLE FOR SENSOR	449 172 ... 0	Part No.
1	TRISTOP BRAKE ACTUATOR	911 002 9... 0	15 2 EXTENSION CABLE FOR SENSOR	449 172 ... 0	Part No.
1	TRISTOP BRAKE ACTUATOR	982 201 ... 0	14 1 TEST CONNECTION	449 172 ... 0	Part No.
1	TRISTOP BRAKE ACTUATOR	982 201 ... 0	13 1 TEST CONNECTION	449 172 ... 0	Part No.
1	TRISTOP BRAKE ACTUATOR	982 201 ... 0	12 1 TEST CONNECTION	449 172 ... 0	Part No.
1	TRISTOP BRAKE ACTUATOR	982 201 ... 0	11 1 TEST CONNECTION	449 172 ... 0	Part No.
1	TRISTOP BRAKE ACTUATOR	982 201 ... 0	10 1 TEST CONNECTION	449 172 ... 0	Part No.
1	TRISTOP BRAKE ACTUATOR	982 201 ... 0	9 1 TEST CONNECTION	449 172 ... 0	Part No.
1	TRISTOP BRAKE ACTUATOR	982 201 ... 0	8 1 TEST CONNECTION	449 172 ... 0	Part No.
1	TRISTOP BRAKE ACTUATOR	982 201 ... 0	7 1 TEST CONNECTION	449 172 ... 0	Part No.
1	TRISTOP BRAKE ACTUATOR	982 201 ... 0	6 1 TEST CONNECTION	449 172 ... 0	Part No.
1	TRISTOP BRAKE ACTUATOR	982 201 ... 0	5 1 TEST CONNECTION	449 172 ... 0	Part No.
1	TRISTOP BRAKE ACTUATOR	982 201 ... 0	4 1 TEST CONNECTION	449 172 ... 0	Part No.
1	TRISTOP BRAKE ACTUATOR	982 201 ... 0	3 1 TEST CONNECTION	449 172 ... 0	Part No.
1	TRISTOP BRAKE ACTUATOR	982 201 ... 0	2 1 TEST CONNECTION	449 172 ... 0	Part No.
1	TRISTOP BRAKE ACTUATOR	982 201 ... 0	1 1 TEST CONNECTION	449 172 ... 0	Part No.
1	TRISTOP BRAKE ACTUATOR	982 201 ... 0	0 1 TEST CONNECTION	449 172 ... 0	Part No.

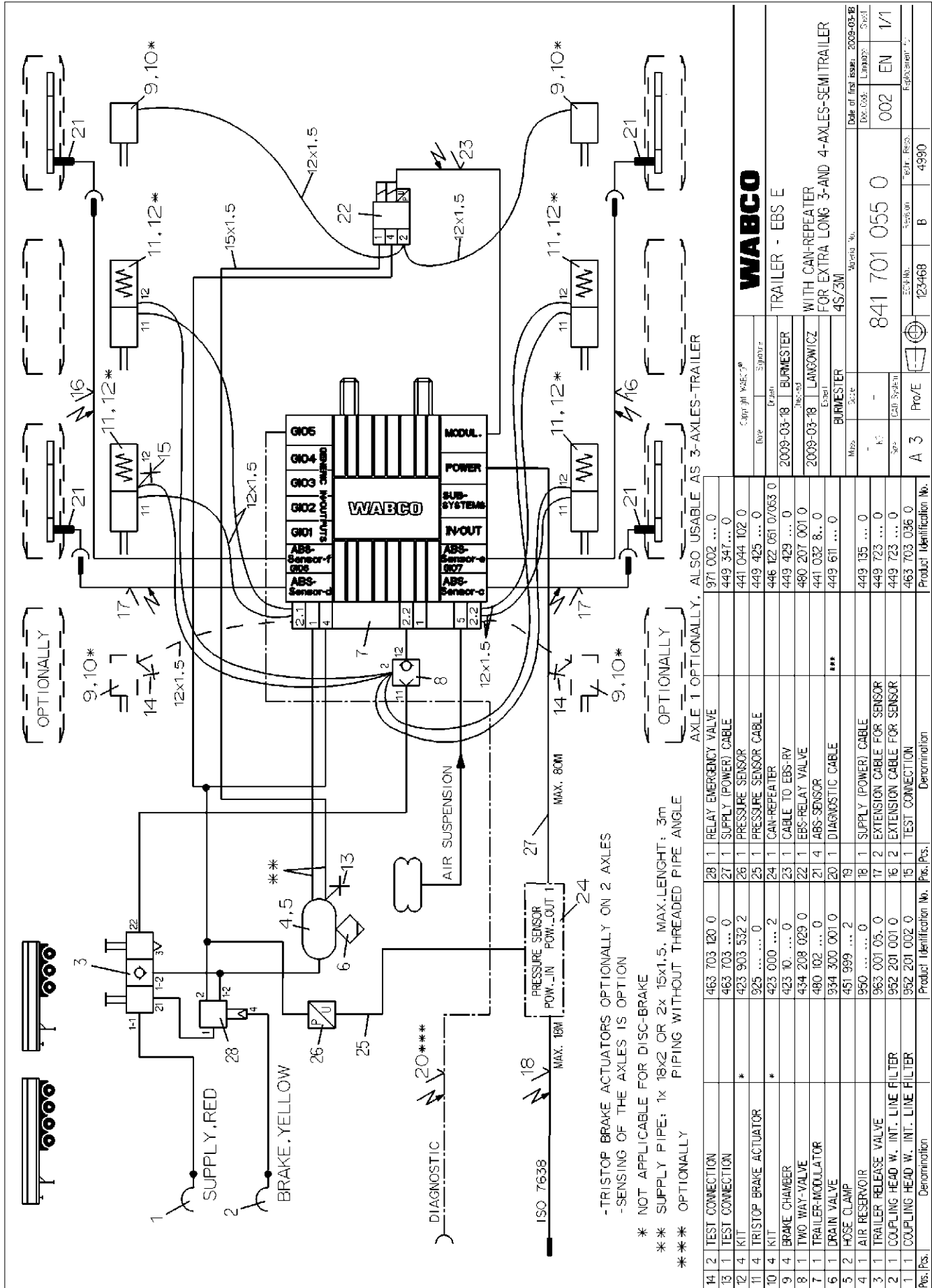

WABCO		Date		2009-03-18	
		Dash		BURMESTER	
		Modus		2009-03-18 LANGMOWICZ	
		Ersatz		BURMESTER	
		Art-Nr.		449 611 ... 0	
		Modus		449 135 ... 0	
		Art-Nr.		449 723 ... 0	
		Art-Nr.		449 723 ... 0	
		Art-Nr.		463 703 036 0	
		Art-Nr.		449 135 ... 0	
		Art-Nr.		449 723 ... 0	
		Art-Nr.		449 723 ... 0	
		Art-Nr.		463 703 036 0	

WABCO		Date		2009-03-18	
		Dash		BURMESTER	
		Modus		2009-03-18 LANGMOWICZ	
		Ersatz		BURMESTER	
		Art-Nr.		449 611 ... 0	
		Modus		449 135 ... 0	
		Art-Nr.		449 723 ... 0	
		Art-Nr.		449 723 ... 0	
		Art-Nr.		463 703 036 0	
		Art-Nr.		449 135 ... 0	
		Art-Nr.		449 723 ... 0	
		Art-Nr.		449 723 ... 0	
		Art-Nr.		463 703 036 0	

841 701 056 0

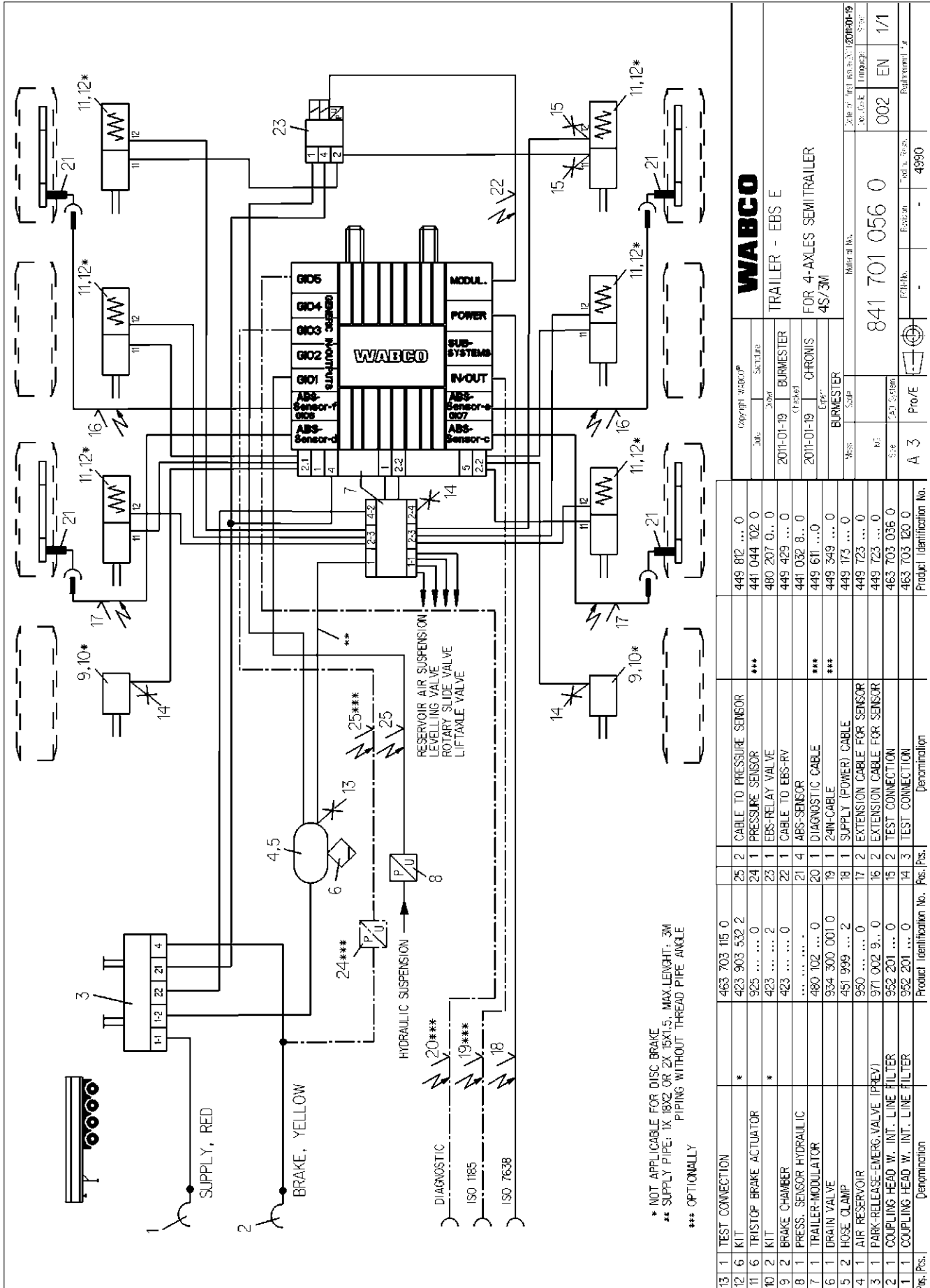

WABCO

TRAILER - EBS E
FOR 4-AXLES SEMI TRAILER
4S/3M

Part No.	841 701 056 0
Rev.	002
EN	1/1

Fig. Pos.	Denomination	Product Identification No.	Pos. Pos.	Denomination	Product Identification No.
13	1 TEST CONNECTION	463 703 115 0			
12	6 KIT	423 903 532 2	25	2 CABLE TO PRESSURE SENSOR	449 812 ... 0
11	6 TRISTOP BRAKE ACTUATOR	925 0	24	1 PRESSURE SENSOR	441 044 102 0
10	2 KIT	423 2	23	1 EBS-RELAY VALVE	480 207 0.. 0
9	2 BRAKE CHAMBER	423 0	22	1 CABLE TO EBS-RV	449 429 ... 0
8	1 PRESS. SENSOR HYDRAULIC	...	21	4 ABS-SENSOR	441 032 8... 0
7	1 TRAILER-MODULATOR	480 102 ... 0	20	1 DIAGNOSTIC CABLE	449 611 ... 0
6	1 DRAIN VALVE	934 300 001 0	19	1 24IN-CABLE	449 349 ... 0
5	2 HOSE CLAMP	451 999 ... 2	18	1 SUPPLY (POWER) CABLE	449 173 ... 0
4	1 AIR RESERVOIR	950 0	17	2 EXTENSION CABLE FOR SENSOR	449 723 ... 0
3	1 PARK-RELEASE-EMERG.VALVE (PREV)	971 002 9.. 0	16	2 EXTENSION CABLE FOR SENSOR	449 723 ... 0
2	1 COUPLING HEAD W. INT. LINE FILTER	952 201 ... 0	15	2 TEST CONNECTION	463 703 036 0
1	1 COUPLING HEAD W. INT. LINE FILTER	952 201 ... 0	14	3 TEST CONNECTION	463 703 120 0

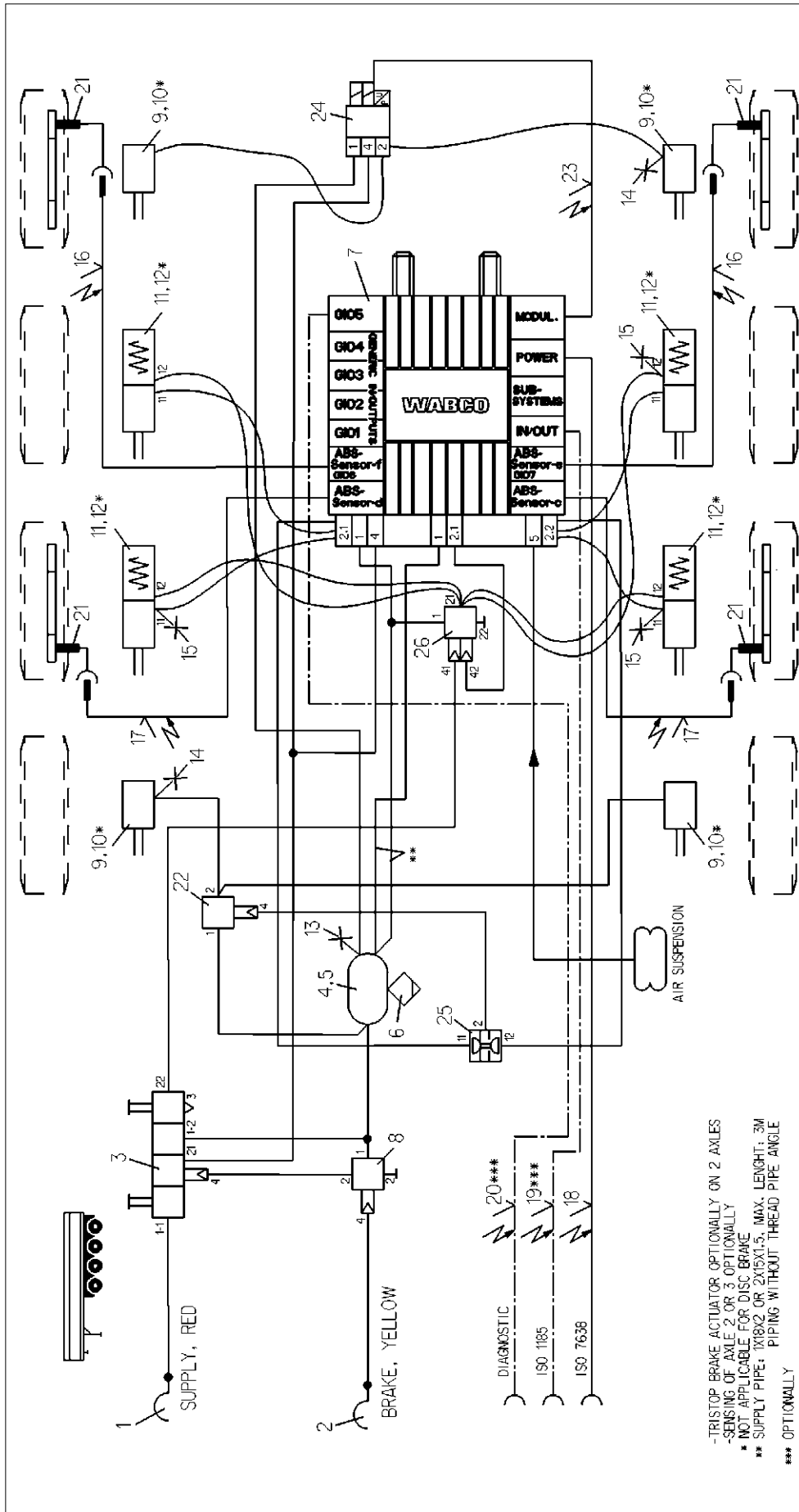

-TRISTOP BRAKE ACTUATOR OPTIONAL ON 2 AXLES
 -SENSING OF AXLE 2 OR 3 OPTIONAL
 * NOT APPLICABLE FOR DISC BRAKE
 ** SUPPLY PIPE: 1/8X2 OR 2/16X1.5, MAX. LENGTH: 3M
 PIPING WITHOUT THREAD PIPE ANGLE
 *** OPTIONALLY

13	1	TEST CONNECTION	463 703 115 0	26	1	OVERLOAD PROTECTION-RV	973 011 201 0
12	4	KIT	423 903 532 2	25	1	DOUBLE SHUT-OFF VALVE	434 500 003 0
11	4	TRISTOP BRAKE ACTUATOR	925 ... 0	24	1	EBB-RELAY VALVE	480 207 0... 0
10	4	KIT	423 000 ... 2	23	1	CABLE TO EBB-RV	449 429 ... 0
9	4	BRAKE CHAMBER	423 10... 0	22	1	RELAY VALVE	973 011 000 0
8	1	RELAY VALVE	973 011 0... 0	21	4	ABS-SENSOR	441 032 8... 0
7	1	TRAILER-MODULATOR	480 102 06... 0	20	1	DIAGNOSTIC CABLE	449 611 ... 0
6	1	DRAIN VALVE	934 300 001 0	19	1	24H-CABLE	449 349 ... 0
5	2	HOSE CLAMP	451 999 ... 2	18	1	SUPPLY (POWER) CABLE	449 173 ... 0
4	1	AIR RESERVOIR	950 ... 0	17	2	EXTENSION CABLE FOR SENSOR	449 723 ... 0
3	1	PARK-RELEASE-EMERG.-VALVE (PREV)	971 002 9... 0	16	2	EXTENSION CABLE FOR SENSOR	449 723 ... 0
2	1	COUPLING HEAD W.INT. LINE FILTER	952 201 ... 0	15	3	TEST CONNECTION	463 703 036 0
1	1	COUPLING HEAD W.INT. LINE FILTER	952 201 ... 0	14	2	TEST CONNECTION	463 703 120 0
Fig. Pcs.		Denomination	Product Identification No.	Fig. Pcs.		Denomination	Product Identification No.

WABCO
 TRAILER - EBS E
 FOR 4-AXLES-SEMI TRAILER
 4S/3M AXLE 1 SELECT LOW

Material No.
 841 701 059 0

Part No.
 124063

Part. Ref.
 A

Part. Ref.
 4990

Ex. Code
 002

Ex. Code
 EN

Ex. Code
 1/1

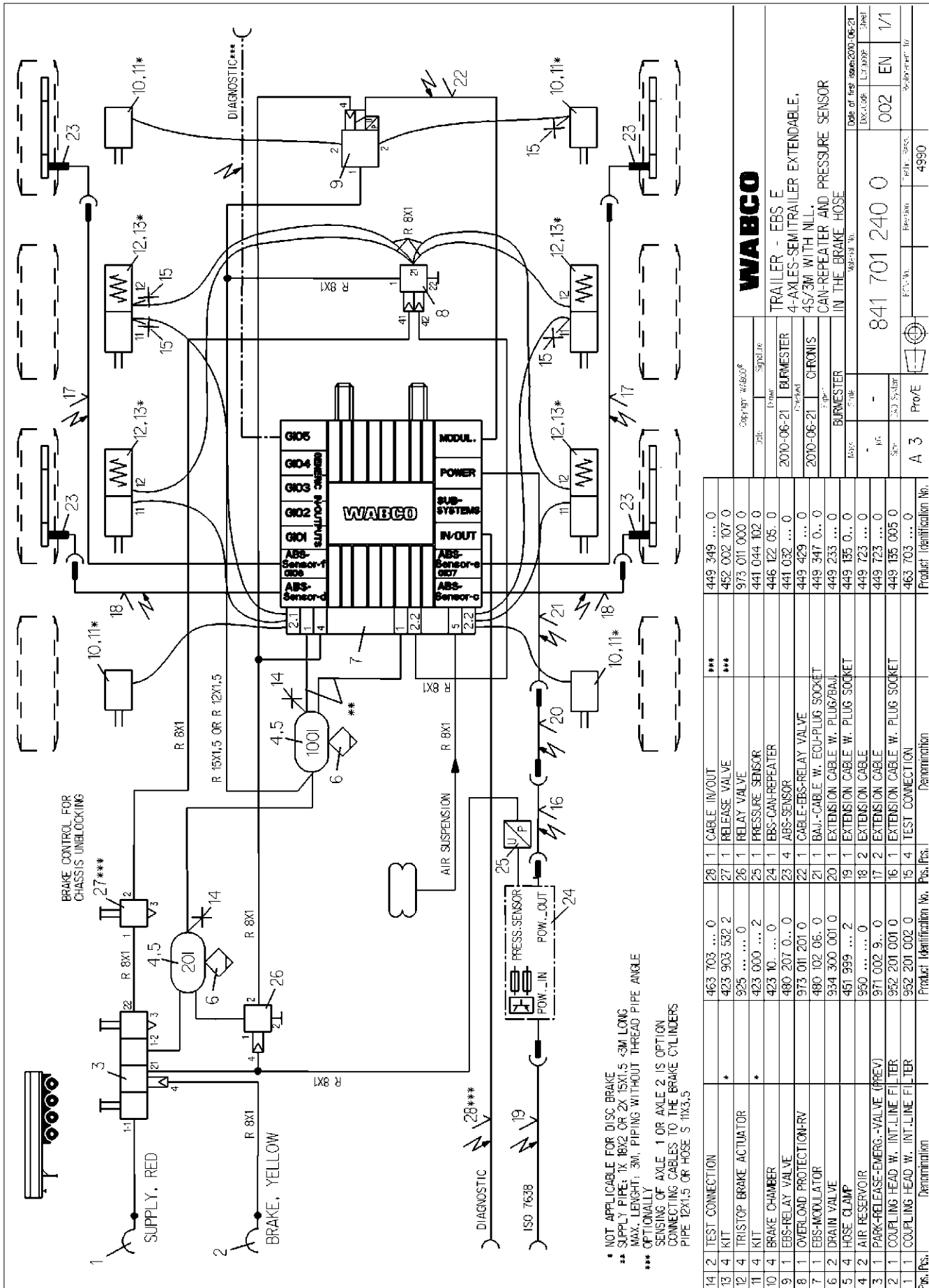

841 701 241 0

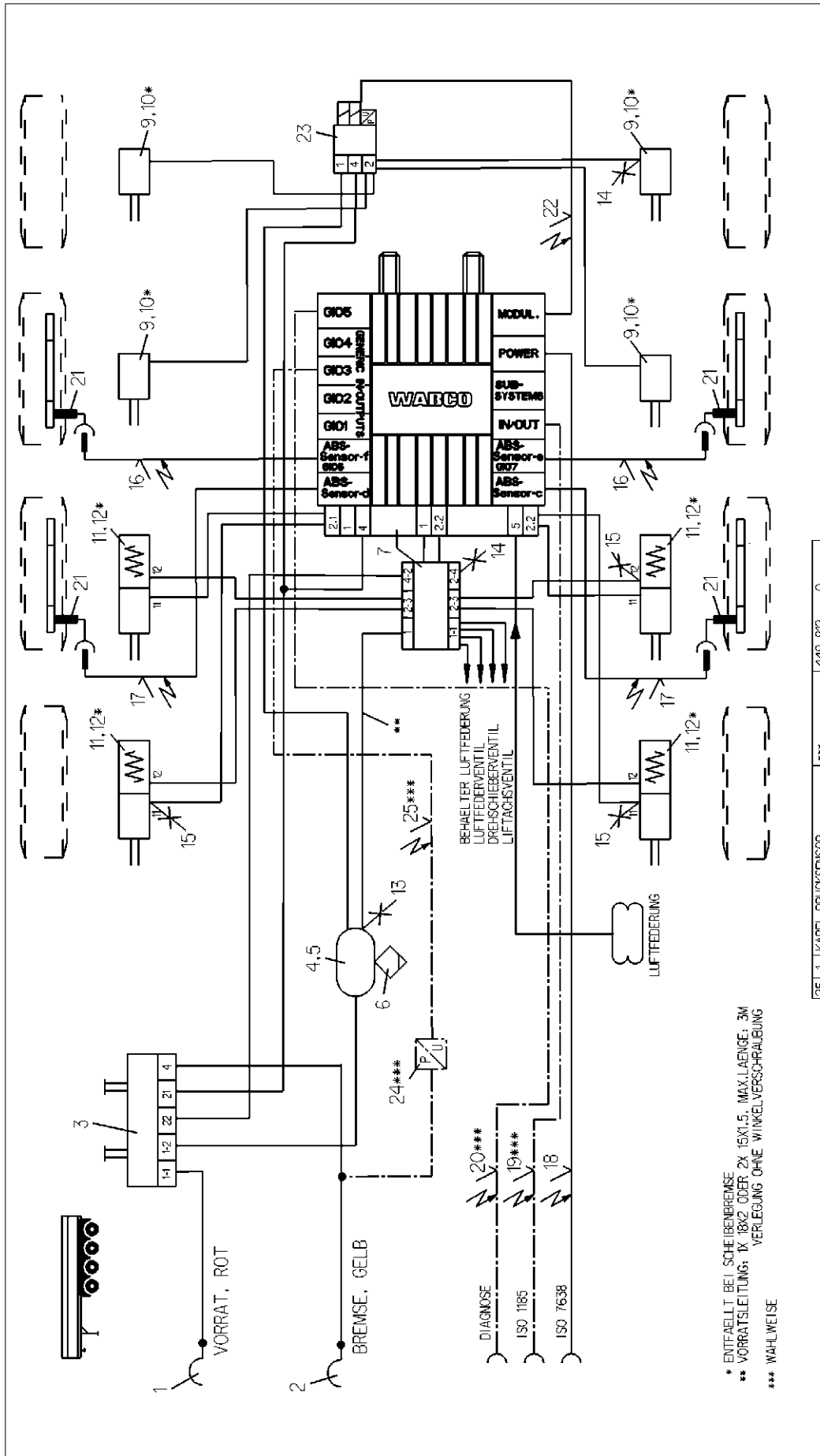

* ENTFALTET BEI SICHERBREMSE
 ** VORRATSLAENGE: 1X 18X2 ODER 2X 15X1,5, MAX. LAENGE: 3M
 VERLEGUNG OHNE WINKELVERSCHRAEBUNG
 *** WAHLWEISE

Date		Signature	
Date	Drawn	Date	Signature
2010-08-03	BURMESTER	2010-08-03	CHRONIS
Litho		Epoxy	
Scale		Scale	
1:1		1:1	
300 System		300 System	
A 3		A 3	
Pro/E		Pro/E	
Product Identification No.		Product Identification No.	
449 812 ... 0		449 812 ... 0	
441 040 013 0		441 040 013 0	
480 207 0... 0		480 207 0... 0	
449 429 ... 0		449 429 ... 0	
441 032 8... 0		441 032 8... 0	
449 611 ... 0		449 611 ... 0	
449 349 ... 0		449 349 ... 0	
449 173 ... 0		449 173 ... 0	
449 723 ... 0		449 723 ... 0	
463 703 036 0		463 703 036 0	
463 703 120 0		463 703 120 0	
463 703 115 0		463 703 115 0	
Product Identification No.		Product Identification No.	
Denomination		Denomination	
KABEL-DRUCKSENSOR		KABEL-DRUCKSENSOR	
DRUCKSENSOR		DRUCKSENSOR	
EBS-RELAISVENTIL		EBS-RELAISVENTIL	
KABEL ZUM EBS-RV		KABEL ZUM EBS-RV	
MEMBRANZYLINDER		MEMBRANZYLINDER	
DIAGNOSEKABEL		DIAGNOSEKABEL	
24N-KABEL		24N-KABEL	
VERSORGUNGSKABEL		VERSORGUNGSKABEL	
VERLAENGERUNGSKABEL FUER SENSOR		VERLAENGERUNGSKABEL FUER SENSOR	
PREFANSCHLUSS		PREFANSCHLUSS	
KUPPLUNGSKOPF M.INT. LEITUNGSFILTER		KUPPLUNGSKOPF M.INT. LEITUNGSFILTER	
KUPPLUNGSKOPF M.INT. LEITUNGSFILTER		KUPPLUNGSKOPF M.INT. LEITUNGSFILTER	

WABCO
 TRAILER - EBS E
 FUER 4-ACHS-SATTELANHAENGER
 4S/3M

Date of first issue: 2010-08-03
 Rev. No.: 1
 Sheet: 1/1

841 701 241 0
 Rev. No.: 002
 Edition: DE

124983
 Rev. No.: A
 Edition: 4990

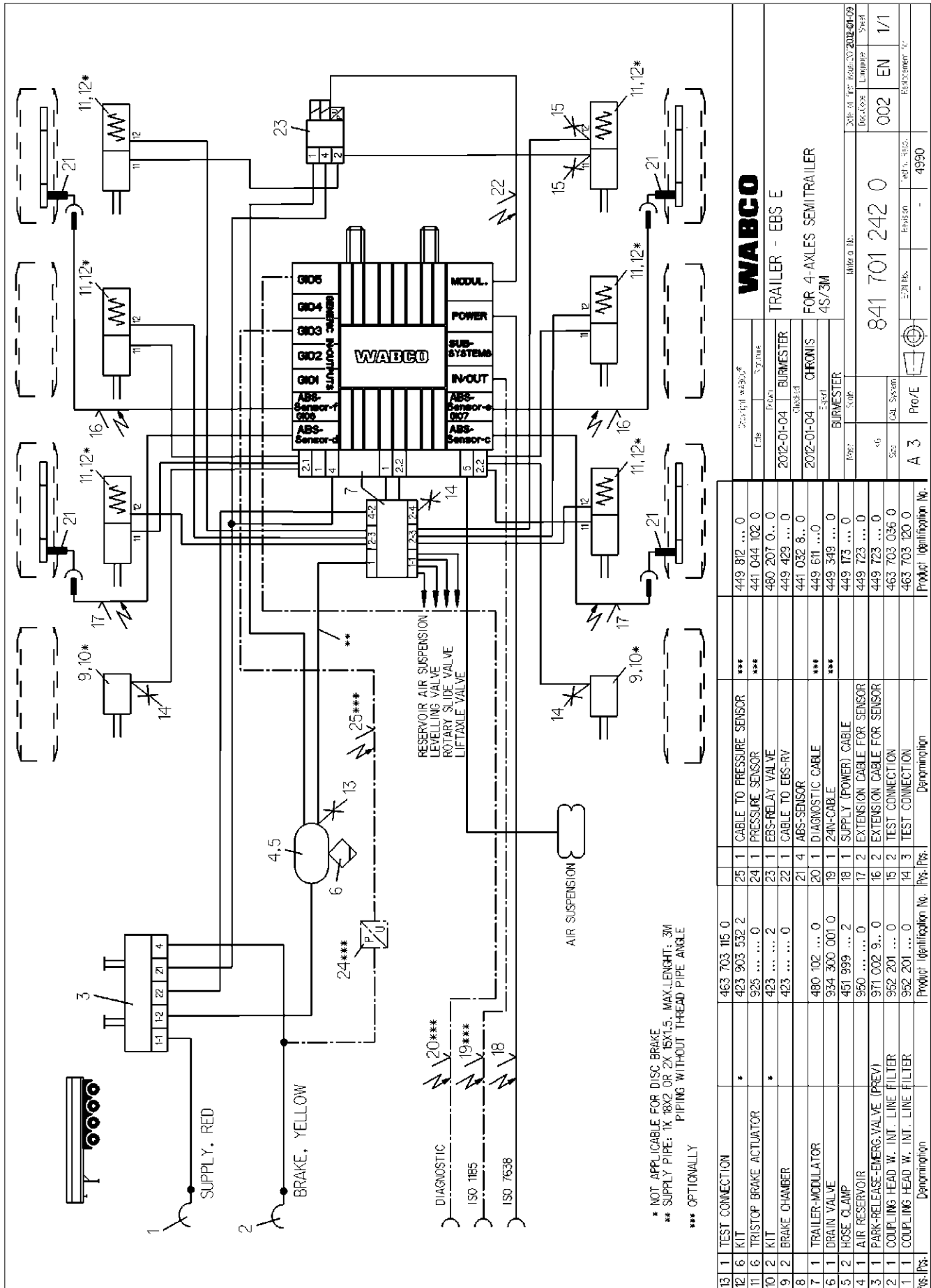

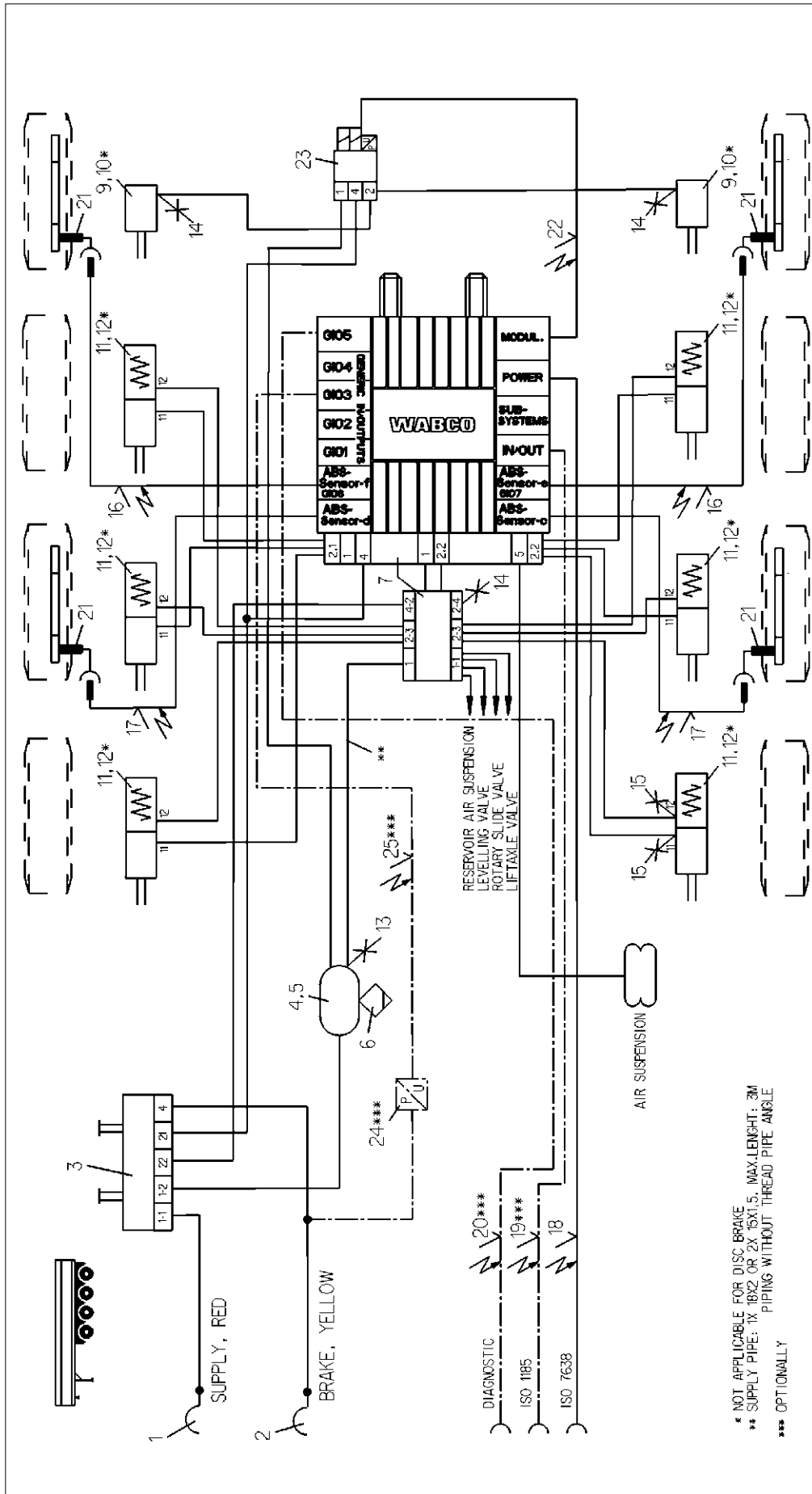

* NOT APPLICABLE FOR DISC BRAKE
 ** SUPPLY PIPE: 1X 18X2 OR 2X 15X1.5, MAX. LENGTH: 3M
 PIPING WITHOUT THREAD PIPE ANGLE
 *** OPTIONALLY

WABCO		TRAILER - EBS E	
2001 01 30 18500001002-01-11		2002-01-04 BURMESTER	
2002-01-04 GROMIS		FOR 4-AXLES SEMI TRAILER 4S/3M	
BURMESTER		BURMESTER	
Scale		Scale	
46		46	
See G46 System		See G46 System	
A 3		A 3	
Prüf. No.		Prüf. No.	
4990		4990	
Identifikation No.		Identifikation No.	
841 701 244 0		841 701 244 0	
EN		EN	
1/1		1/1	
13	1 TEST CONNECTION	463 703 115 0	
12	6 KIT	423 903 532 2	25 1 CABLE TO PRESSURE SENSOR
11	6 TRISTOP BRAKE ACTUATOR	925 0	24 1 PRESSURE SENSOR
10	2 KIT	423 2	23 1 EBS-RELAY VALVE
9	2 BRAKE CHAMBER	423 0	22 1 CABLE TO EBS-RV
8		21 4	ABS-SENSOR
7	1 TRAILER-MODULATOR	480 102 ... 0	20 1 DIAGNOSTIC CABLE
6	1 DRAIN VALVE	934 300 001 0	19 1 2-IN-CABLE
5	2 HOSE CLAMP	451 999 ... 2	18 1 SUPPLY (POWER) CABLE
4	1 AIR RESERVOIR	950 0	17 2 EXTENSION CABLE FOR SENSOR
3	1 PARK-RELEASE-EMERG. VALVE (PREV)	971 002 9... 0	16 2 EXTENSION CABLE FOR SENSOR
2	1 COUPLING HEAD W. INT. LINE FILTER	952 201 ... 0	15 2 TEST CONNECTION
1	1 COUPLING HEAD W. INT. LINE FILTER	952 201 ... 0	14 3 TEST CONNECTION

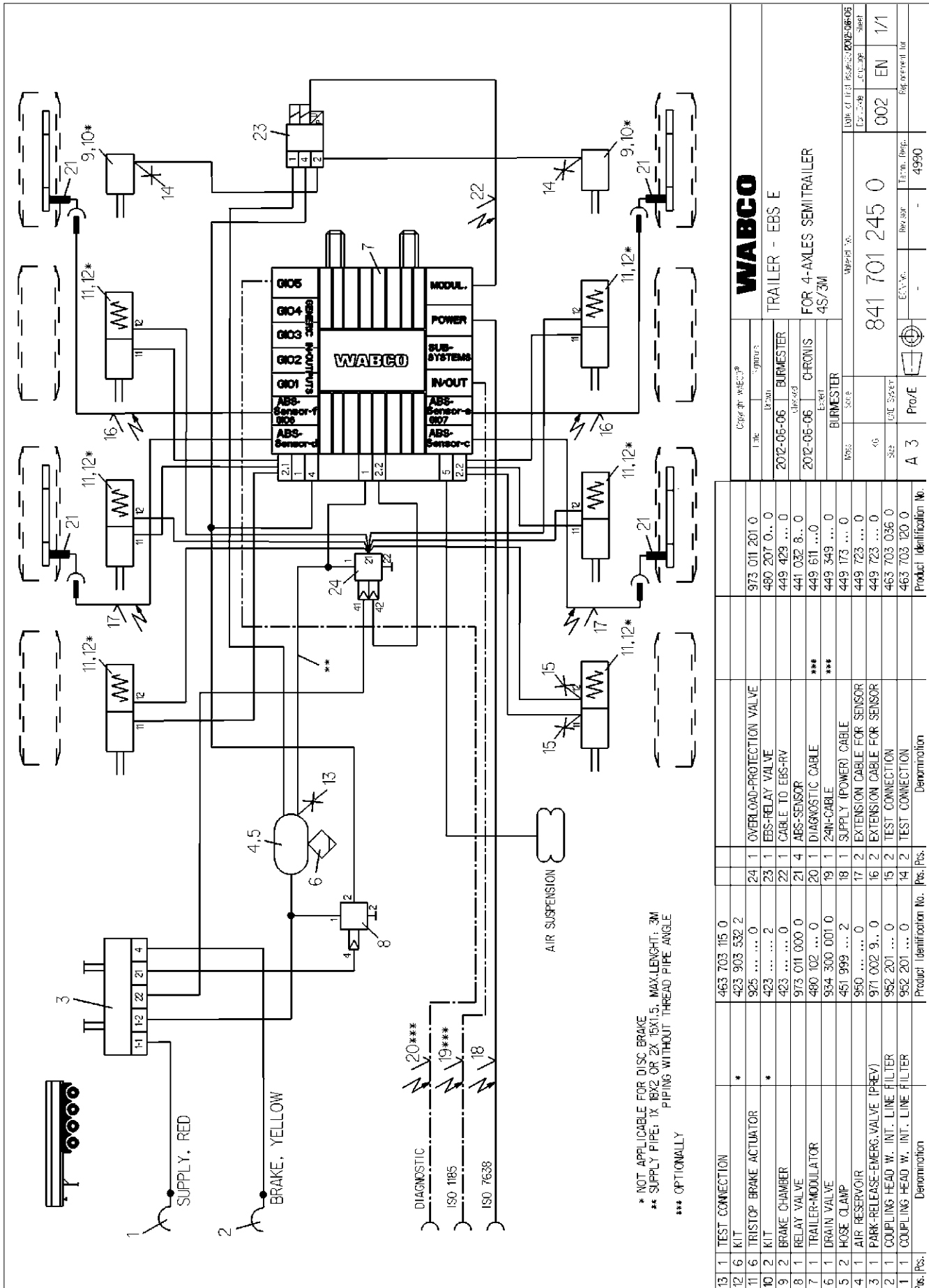

* NOT APPLICABLE FOR DISC BRAKE
 ** SUPPLY PIPE: 1X BX2 OR 2X 15X1.5, MAX LENGTH: 3M
 PIPING WITHOUT THREAD PIPE ANGLE
 *** OPTIONALLY

Type No. WABCO		Symbol	
Line	Version	Line	Version
2012-06-06	BURMESTER		
2012-06-06	CHRONIS		
	BURMESTER		
	WABCO No.		
	841 701 245 0		
	ECU No.		
	Rev. sup.		
	Term. (dep.)		
	4990		
	002		
	EN		
	1/1		
	Reference for		

Pos./Pos.	Denomination	Product Identification No.	Pos./Pos.	Denomination	Product Identification No.
13	1 TEST CONNECTION	463 703 115 0			
12	6 KIT	423 903 532 2			
11	6 TRISTOP BRAKE ACTUATOR	925 0	24	1 OVERLOAD-PROTECTION VALVE	973 011 201 0
10	2 KIT	423 2	23	1 EBS-RELAY VALVE	480 207 0... 0
9	2 BRAKE CHAMBER	423 0	22	1 CABLE TO EBS-RV	449 429 ... 0
8	1 RELAY VALVE	973 011 000 0	21	4 ABS-SENSOR	441 032 8... 0
7	1 TRAILER-MODULATOR	480 102 ... 0	20	1 DIAGNOSTIC CABLE	449 611 ... 0
6	1 DRAIN VALVE	934 300 001 0	19	1 24IN-CABLE	449 349 ... 0
5	2 HOSE CLAMP	451 999 ... 2	18	1 SUPPLY (POWER) CABLE	449 173 ... 0
4	1 AIR RESERVOIR	950 2	17	2 EXTENSION CABLE FOR SENSOR	449 723 ... 0
3	1 PARK-RELEASE-EMERG. VALVE (PREV)	971 002 9... 0	16	2 EXTENSION CABLE FOR SENSOR	449 723 ... 0
2	1 COUPLING HEAD W. INT. LINE FILTER	952 201 ... 0	15	2 TEST CONNECTION	463 703 036 0
1	1 COUPLING HEAD W. INT. LINE FILTER	952 201 ... 0	14	2 TEST CONNECTION	463 703 120 0
	Denomination				

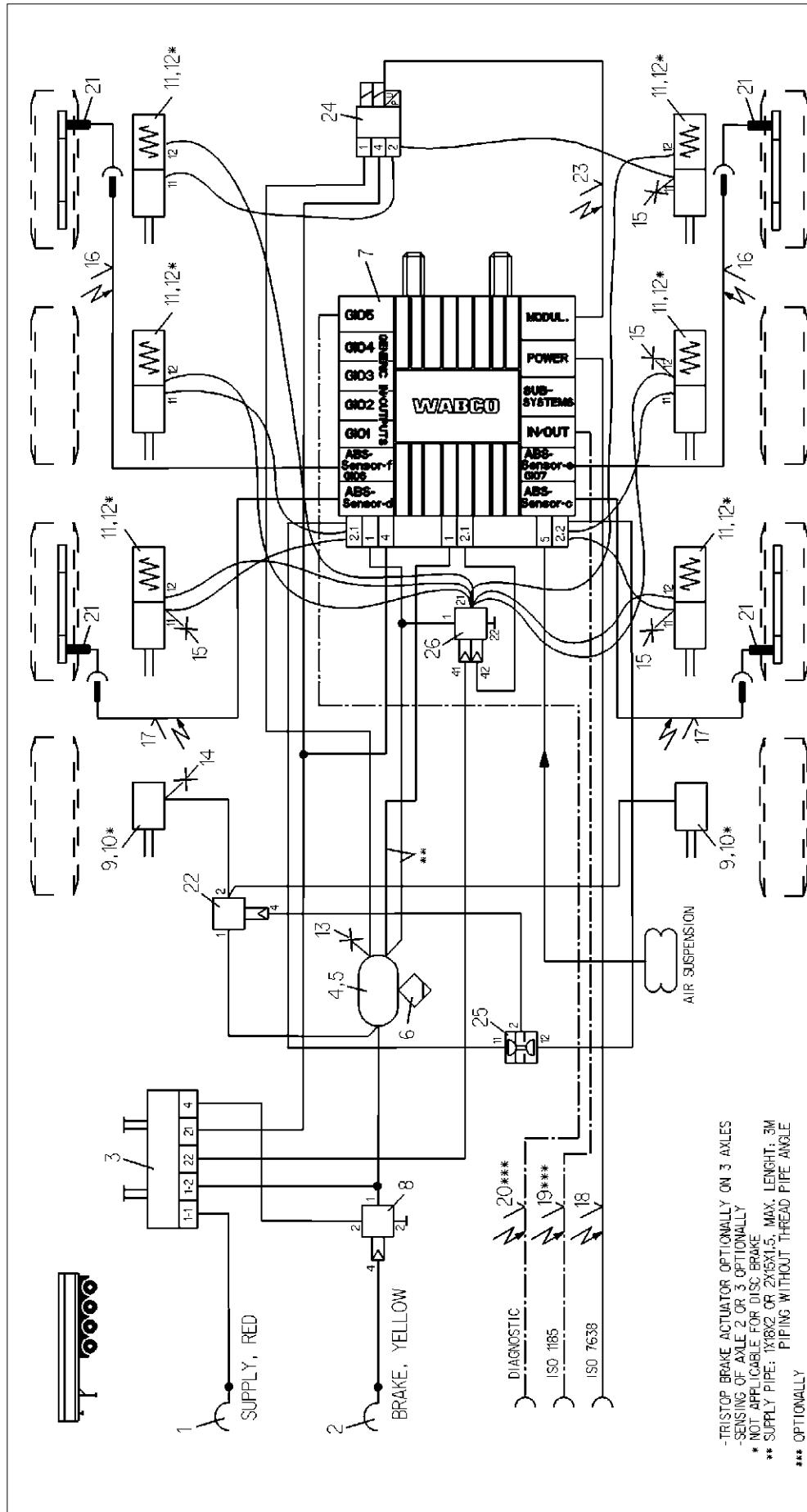

-TRISTOP BRAKE ACTUATOR OPTIONALLY ON 3 AXLES
 -SENSING OF AXLE 2 OR 3 OPTIONALLY
 * NOT APPLICABLE FOR DISC BRAKE
 ** SUPPLY PIPE: 1X18X2 OR 2X15X1.5, MAX. LENGTH: 3M
 PIPING WITHOUT THREAD PIPE ANGLE
 *** OPTIONALLY

13	1	TEST CONNECTION	463 703 115 0	26	1	OVERLOAD PROTECTION-RV	973 011 201 0
12	6	KIT	423 903 532 2	25	1	DOUBLE SHUT-OFF VALVE	434 500 003 0
11	6	TRISTOP BRAKE ACTUATOR	925 0	24	1	EBBS-RELAY VALVE	480 207 0.. 0
10	2	KIT	423 000 ... 2	23	1	CABLE TO EBS-RV	449 429 ... 0
9	2	BRAKE CHAMBER	423 10.. .. 0	22	1	RELAY VALVE	973 011 000 0
8	1	RELAY VALVE	973 011 0.. 0	21	4	ABS-SENSOR	441 032 8.. 0
7	1	TRAILER-MODULATOR	480 102 06 0	20	1	DIAGNOSTIC CABLE	449 611 ... 0
6	1	DRAIN VALVE	934 300 001 0	19	1	2-IN-CABLE	449 349 ... 0
5	2	HOSE CLAMP	451 999 ... 2	18	1	SUPPLY (POWER) CABLE	449 173 ... 0
4	1	AIR RESERVOIR	950 0	17	2	EXTENSION CABLE FOR SENSOR	449 723 ... 0
3	1	PARK-RELEASE-EMERG.-VALVE (PREV)	971 002 9.. 0	16	2	EXTENSION CABLE FOR SENSOR	449 723 ... 0
2	1	COUPLING HEAD W.INT. LINE FILTER	952 201 ... 0	15	4	TEST CONNECTION	463 703 036 0
1	1	COUPLING HEAD W.INT. LINE FILTER	952 201 ... 0	14	1	TEST CONNECTION	463 703 120 0
Pos./Pcs.		Denomination	Product Identification No.	Pos./Pcs.		Denomination	Product Identification No.

WABCO
 TRAILER - EBS E
 FOR 4-AXLES-SEMI TRAILER
 4S/3M AXLE 1 SELECT LOW

DATE OF FIRST ISSUE: 2013-11-19
 BY: 3346 Computer 5984

841 701 246 0

EN 1/1

4990

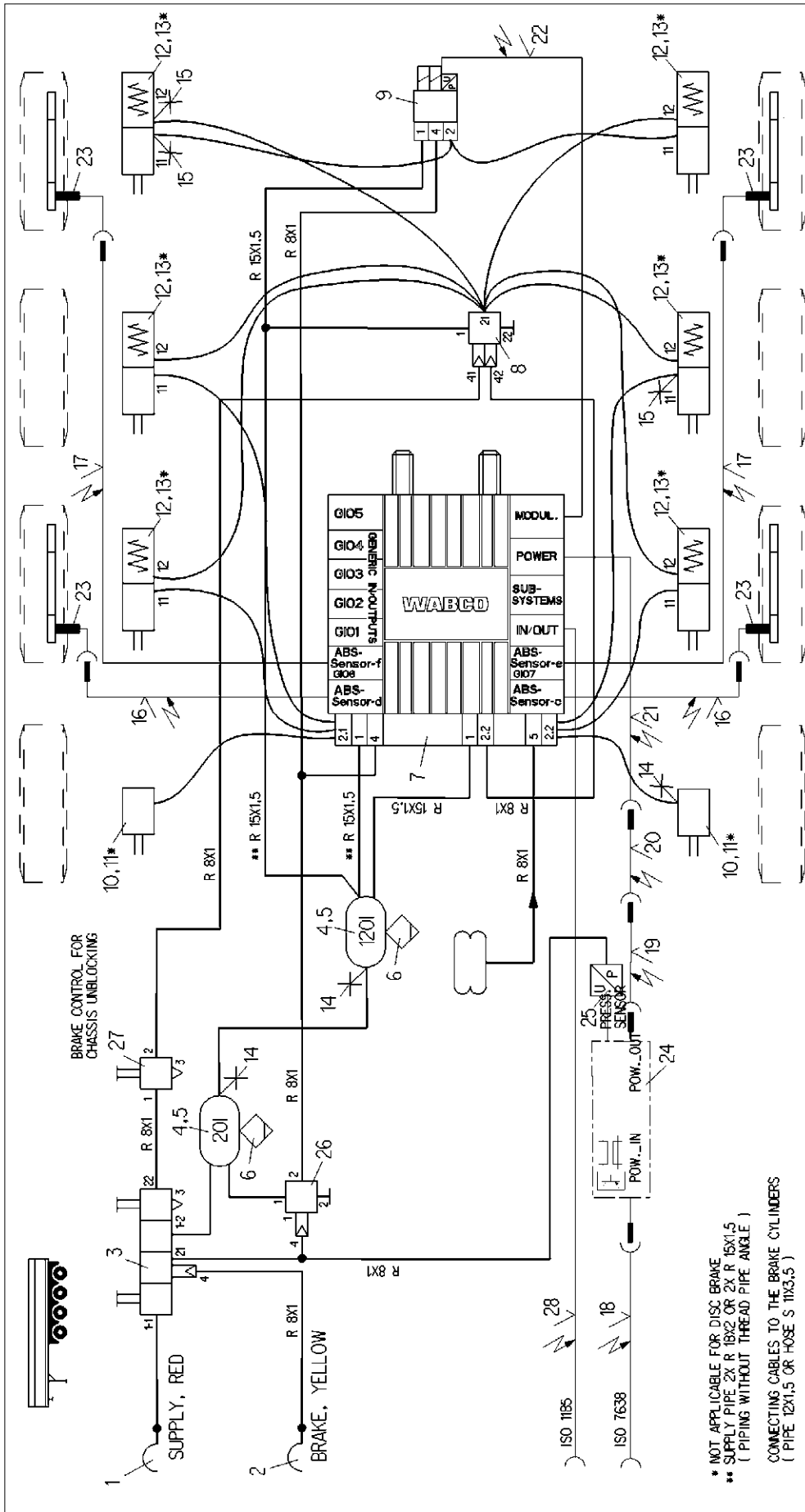

* NOT APPLICABLE FOR DISC BRAKE
 ** SUPPLY PIPE 2X R 18X2 OR 2X R 15X1.5
 (PIPING WITHOUT THREAD PIPE ANGLE)
 CONNECTING CABLES TO THE BRAKE CYLINDERS
 (PIPE 12X1.5 OR HOSE S 11X3.5)

14	3	TEST CONNECTION	463 703 ... 0	28	1	CABLE IN/OUT	449 349 ... 0
13	6	KIT	423 903 532 2	27	1	RELEASE VALVE	963 006 005 0
12	6	TRISTOP BRAKE ACTUATOR	925 ... 0	26	1	RELAY VALVE	973 011 000 0
11	2	KIT	423 ... 2	25	1	PRESSURE SENSOR	441 044 102 0
10	2	BRAKE CHAMBER	423 ... 0	24	1	EBS-CAN-REPEATER	446 122 053 0
9	1	EBS-RELAY VALVE	480 207 0... 0	23	4	ABS-SENSOR	441 032 ... 0
8	1	OVERLOAD PROTECTION-REV	973 011 201 0	22	1	CABLE-EBS-RELAY VALVE	449 429 000 0
7	1	EBS-MODULATOR	480 102 06... 0	21	1	BAJ.-CABLE W. ECU-PLUG SOCKET	449 347 080 0
6	2	DRAIN VALVE	934 300 001 0	20	1	BAJ.-CABLE WITH PLUG SOCKET	449 133 120 0
5	4	HOSE CLAMP	451 999 ... 2	19	1	BAJ.-CABLE WITH PLUG	449 231 120 0
4	2	AIR RESERVOIR	950 ... 0	18	1	V-CABLE WITH PLUG SOCKET	449 135 0... 0
3	1	PARK-RELEASE-EMERG. VALVE (PREV)	971 002 9... 0	17	2	EXTENSION CABLE	449 723 ... 0
2	1	COUPLING HEAD W. INT.L.I.ME FILTER	952 201 001 0	16	2	EXTENSION CABLE	449 723 ... 0
1	1	COUPLING HEAD W. INT.L.I.ME FILTER	952 201 002 0	15	3	TEST CONNECTION	463 703 ... 0
Pos./Pcs.		Denomination	Product Identification No.	Pos./Pcs.		Denomination	Product Identification No.

WABCO

TRAILER - EBS E
 4-AXLES-SEMITRAILER EXTENDABLE,
 EBS-4S/3M CAN-REPEATER,
 RELAY VALVE AND PRESSURE SENSOR
 IN THE BRAKE HOSE

Doc. Code	002	EN	1/1
Date of first issue	2015-04-14		
Doc. type	Sheet		

Part No.	841 701 247 0	Techn. Reg.	4990
Doc. No.	841 701 247 0	Doc. No.	HMR 00479

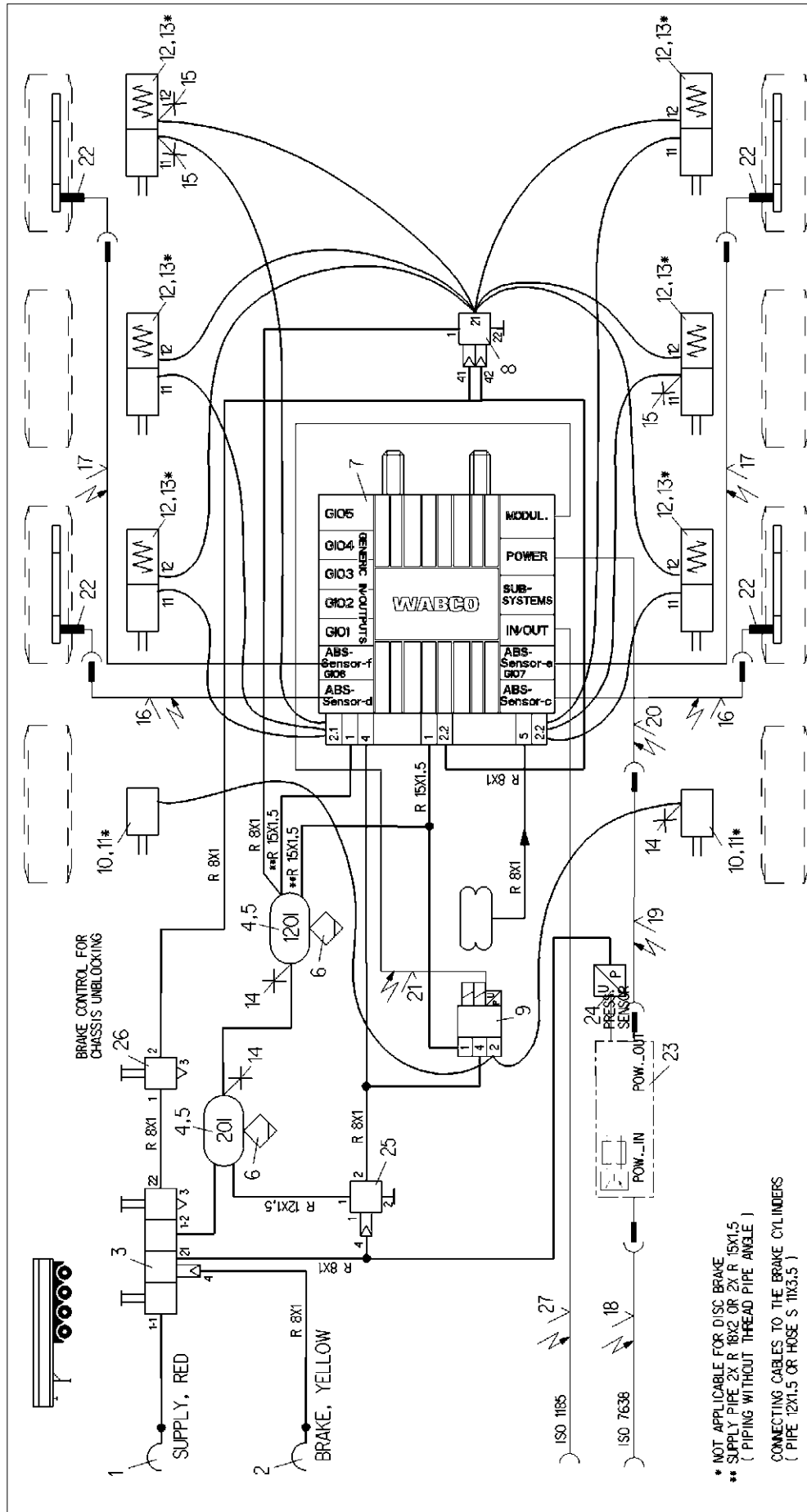

* NOT APPLICABLE FOR DISC BRAKE
 ** SUPPLY PIPE 2X R 18X2 OR 2X R 15X1.5
 (PIPING WITHOUT THREAD PIPE ANGLE)
 CONNECTING CABLES TO THE BRAKE CYLINDERS
 (PIPE 12X1.5 OR HOSE S 11X3.5)

Fig. Pcs.	Denomination	Product Identification No.	Pcs. Pcs.	Denomination	Product Identification No.
14	3 TEST CONNECTION	463 703 ... 0	28	CABLE IN/OUT	449 349 ... 0
13	6 KIT	423 903 532 2	27	1 RELEASE VALVE	963 006 005 0
12	6 TRISTOP BRAKE ACTUATOR	925 ... 0	26	1 RELAY VALVE	973 011 000 0
11	2 KIT	423 ... 2	25	1 PRESSURE SENSOR	441 044 102 0
10	2 BRAKE CHAMBER	423 ... 0	24	1 EBS-CAN-REPEATER	446 122 053 0
9	1 EBS-RELAY VALVE	480 207 0.. 0	23	4 ABS-SENSOR	441 032 ... 0
8	1 OVERLOAD PROTECTION-RV	973 011 201 0	22	4 CABLE-EBS-RELAY VALVE	449 429 000 0
7	1 EBS-MODULATOR	480 102 06.. 0	21	1 BAJ.-CABLE W. EQUI-PLUG SOCKET	449 347 003 0
6	2 DRAIN VALVE	934 300 001 0	20	1 V-CABLE-EXTENSION DIN-BAJ. 40M	894 600 032 0
5	4 HOSE CLAMP	451 999 ... 2	19	1 V-CABLE WITH PLUG SOCKET	449 135 0.. 0
4	2 AIR RESERVOIR	950 ... 0	18	2 EXTENSION CABLE	449 723 ... 0
3	1 PARK-RELEASE-EMERG. VALVE (PREV)	971 002 9.. 0	17	2 EXTENSION CABLE	449 723 ... 0
2	1 COUPLING HEAD W. INT.LINE FILTER	952 201 001 0	16	2 TEST CONNECTION	463 703 ... 0
1	1 COUPLING HEAD W. INT.LINE FILTER	952 201 002 0	15	3	

WABCO
 TRAILER - EBS E
 4-AXLES-SEMITRAILER EXTENDABLE,
 EBS-4S/3M CAN-REPEATER,
 RELAY VALVE AND PRESSURE SENSOR
 IN THE BRAKE HOSE

Copyright WABCO
 Date: 2015-04-20
 Signal: Burmester
 Scale: Burmester

2015-04-20 | BURMESTER
 2015-04-20 | CHRONIS
 Burmester

Part of first issue 2015-04-20
 Date of first issue 2015-04-20
 841 701 248 0
 002 EN 1/1
 HWR 00493

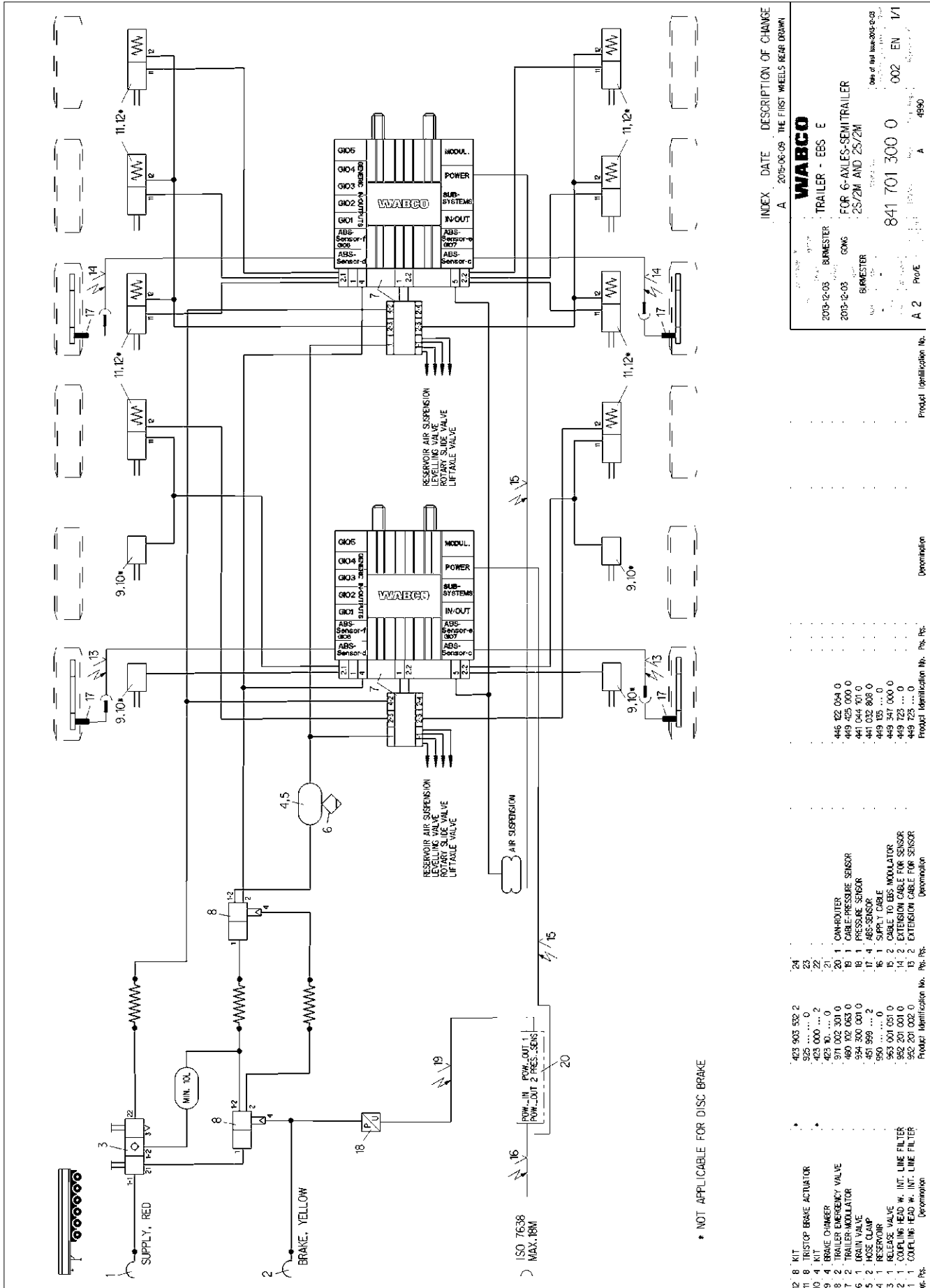

INDEX DATE DESCRIPTION OF CHANGE
A 2005-05-09 THE FIRST WHEELS REAR DRAWN

WABCO

TRAILER - EBS E

FOR 6-AXLES-SEMITRAILER
2S/2M AND 2S/2M

One of the last drawings

2005-12-03 BARNISTER
2003-12-03 GONG
BARNISTER

841 701 300 0
002 EN 1/1
A 2 PROE
A 4990

No. Pcs.	Description	Product Identification No.	Pcs. Pcs.
12	8 KIT		
11	8 TRISTOP BRAKE ACTUATOR	423 903 532 2	24
10	4 KIT	925 ... 0	23
9	4 BRAKE CHAMBER	423 000 ... 2	22
8	2 TRAILER EMERGENCY VALVE	371 002 301 0	20
7	2 TRAILER-MODULATOR	980 192 063 0	19
6	2 RELEASE VALVE	924 999 00 0	18
5	2 MASS CLIP	467 999 ... 2	17
4	1 RESERVOIR	950 000 ... 0	16
3	1 RELEASE VALVE	563 001 031 0	15
2	1 COUPLING HEAD W. INT. LINE FILTER	982 201 001 0	14
1	1 COUPLING HEAD W. INT. LINE FILTER	982 201 002 0	13
		Product Identification No.	Pcs. Pcs.
		445 62 054 0	
		449 423 000 0	
		441 032 803 0	
		449 195 ... 0	
		449 347 000 0	
		449 723 ... 0	
		449 723 ... 0	
		Product Identification No.	Pcs. Pcs.
		445 62 054 0	
		449 423 000 0	
		441 032 803 0	
		449 195 ... 0	
		449 347 000 0	
		449 723 ... 0	
		449 723 ... 0	
		Product Identification No.	Pcs. Pcs.
		445 62 054 0	
		449 423 000 0	
		441 032 803 0	
		449 195 ... 0	
		449 347 000 0	
		449 723 ... 0	
		449 723 ... 0	

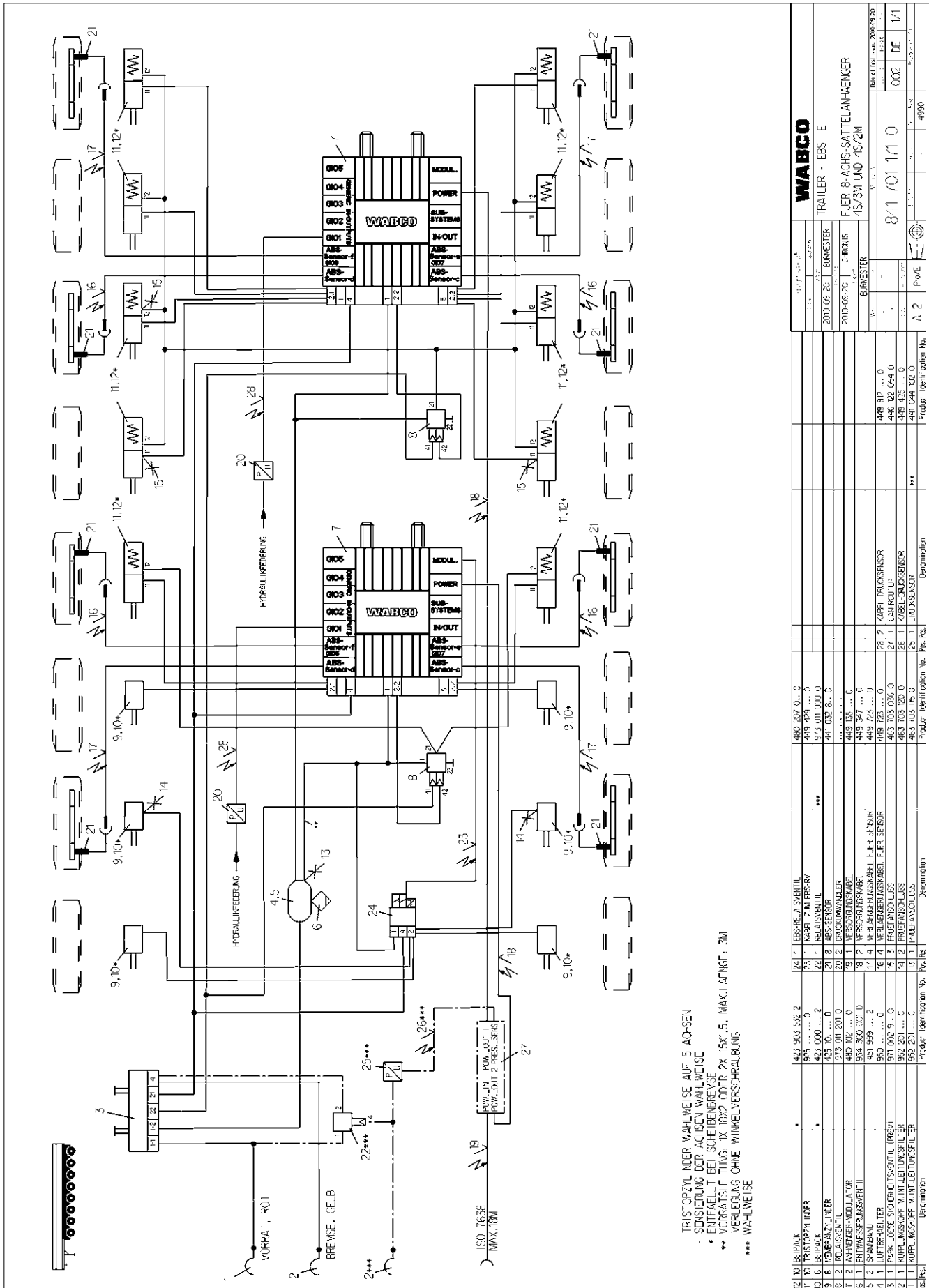

TRISTOPZYL NUR WAHLWEISE AUF 5 AQ-SEN
 - SCHÜBLUNG DER AQ-SEN WAHLWEISE
 - ENTFALTT BEI SCHLEIFENREISE
 ** VORZEITSFÜHRUNG: 1X 18X2 GÖTTE, 2X 15X, 5. MAX. LÄNGE: 3M
 *** WAHLWEISE

WABCO		TRAILER - EBS E	
2000 09 28		BREMSE	
2000 09 28		C-FORM	
BREMSE		BREMSE	
841 701 171 0		841 701 171 0	
499 079 ... 0		499 079 ... 0	
499 075 ... 0		499 075 ... 0	
499 073 ... 0		499 073 ... 0	
499 072 ... 0		499 072 ... 0	
499 071 ... 0		499 071 ... 0	
499 070 ... 0		499 070 ... 0	
499 069 ... 0		499 069 ... 0	
499 068 ... 0		499 068 ... 0	
499 067 ... 0		499 067 ... 0	
499 066 ... 0		499 066 ... 0	
499 065 ... 0		499 065 ... 0	
499 064 ... 0		499 064 ... 0	
499 063 ... 0		499 063 ... 0	
499 062 ... 0		499 062 ... 0	
499 061 ... 0		499 061 ... 0	
499 060 ... 0		499 060 ... 0	
499 059 ... 0		499 059 ... 0	
499 058 ... 0		499 058 ... 0	
499 057 ... 0		499 057 ... 0	
499 056 ... 0		499 056 ... 0	
499 055 ... 0		499 055 ... 0	
499 054 ... 0		499 054 ... 0	
499 053 ... 0		499 053 ... 0	
499 052 ... 0		499 052 ... 0	
499 051 ... 0		499 051 ... 0	
499 050 ... 0		499 050 ... 0	
499 049 ... 0		499 049 ... 0	
499 048 ... 0		499 048 ... 0	
499 047 ... 0		499 047 ... 0	
499 046 ... 0		499 046 ... 0	
499 045 ... 0		499 045 ... 0	
499 044 ... 0		499 044 ... 0	
499 043 ... 0		499 043 ... 0	
499 042 ... 0		499 042 ... 0	
499 041 ... 0		499 041 ... 0	
499 040 ... 0		499 040 ... 0	
499 039 ... 0		499 039 ... 0	
499 038 ... 0		499 038 ... 0	
499 037 ... 0		499 037 ... 0	
499 036 ... 0		499 036 ... 0	
499 035 ... 0		499 035 ... 0	
499 034 ... 0		499 034 ... 0	
499 033 ... 0		499 033 ... 0	
499 032 ... 0		499 032 ... 0	
499 031 ... 0		499 031 ... 0	
499 030 ... 0		499 030 ... 0	
499 029 ... 0		499 029 ... 0	
499 028 ... 0		499 028 ... 0	
499 027 ... 0		499 027 ... 0	
499 026 ... 0		499 026 ... 0	
499 025 ... 0		499 025 ... 0	
499 024 ... 0		499 024 ... 0	
499 023 ... 0		499 023 ... 0	
499 022 ... 0		499 022 ... 0	
499 021 ... 0		499 021 ... 0	
499 020 ... 0		499 020 ... 0	
499 019 ... 0		499 019 ... 0	
499 018 ... 0		499 018 ... 0	
499 017 ... 0		499 017 ... 0	
499 016 ... 0		499 016 ... 0	
499 015 ... 0		499 015 ... 0	
499 014 ... 0		499 014 ... 0	
499 013 ... 0		499 013 ... 0	
499 012 ... 0		499 012 ... 0	
499 011 ... 0		499 011 ... 0	
499 010 ... 0		499 010 ... 0	
499 009 ... 0		499 009 ... 0	
499 008 ... 0		499 008 ... 0	
499 007 ... 0		499 007 ... 0	
499 006 ... 0		499 006 ... 0	
499 005 ... 0		499 005 ... 0	
499 004 ... 0		499 004 ... 0	
499 003 ... 0		499 003 ... 0	
499 002 ... 0		499 002 ... 0	
499 001 ... 0		499 001 ... 0	
499 000 ... 0		499 000 ... 0	

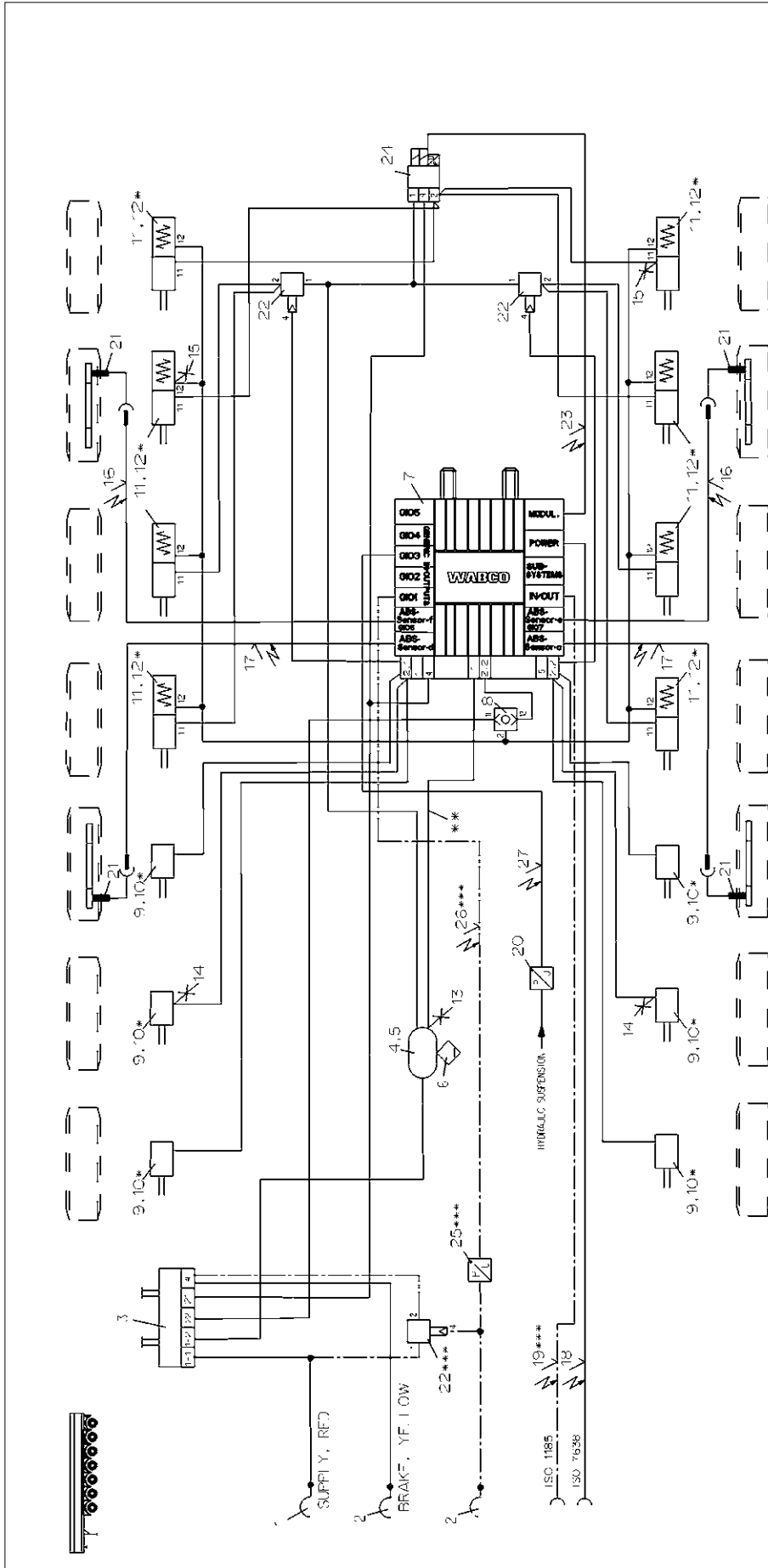

-TRIPSTOP BRAKE ACTUATOR (OPTIONALLY ON 4 AXLES
 -SENSING NO. OF THE AXLES IS OPTION
 * NOT APPLICABLE FOR DISC BRAKE
 ** SUPPL. P FE: 1X18X2 OF 2X15X1.5. MAX. LENGTH: 3M
 PIPING W THOLT THREAD PIPE ANGLE
 *** OPTIONALLY

15	1	TEST CONNECTION	463 703 115 C	249 810 ... 0
16	1	TRIPSTOP BRAKE ACTUATOR	424 904 52 2	249 810 ... 0
17	1	TRIPSTOP BRAKE ACTUATOR	926 ... 0	...
18	1	TRIPSTOP BRAKE ACTUATOR	423 000 ... 2	...
19	1	TRIPSTOP BRAKE ACTUATOR	423 000 ... 2	...
20	1	TRIPSTOP BRAKE ACTUATOR	423 000 ... 2	...
21	1	TRIPSTOP BRAKE ACTUATOR	423 000 ... 2	...
22	1	TRIPSTOP BRAKE ACTUATOR	423 000 ... 2	...
23	1	TRIPSTOP BRAKE ACTUATOR	423 000 ... 2	...
24	1	TRIPSTOP BRAKE ACTUATOR	423 000 ... 2	...
25	1	TRIPSTOP BRAKE ACTUATOR	423 000 ... 2	...
26	1	TRIPSTOP BRAKE ACTUATOR	423 000 ... 2	...
27	1	TRIPSTOP BRAKE ACTUATOR	423 000 ... 2	...
28	1	TRIPSTOP BRAKE ACTUATOR	423 000 ... 2	...
29	1	TRIPSTOP BRAKE ACTUATOR	423 000 ... 2	...
30	1	TRIPSTOP BRAKE ACTUATOR	423 000 ... 2	...
31	1	TRIPSTOP BRAKE ACTUATOR	423 000 ... 2	...
32	1	TRIPSTOP BRAKE ACTUATOR	423 000 ... 2	...
33	1	TRIPSTOP BRAKE ACTUATOR	423 000 ... 2	...
34	1	TRIPSTOP BRAKE ACTUATOR	423 000 ... 2	...
35	1	TRIPSTOP BRAKE ACTUATOR	423 000 ... 2	...
36	1	TRIPSTOP BRAKE ACTUATOR	423 000 ... 2	...
37	1	TRIPSTOP BRAKE ACTUATOR	423 000 ... 2	...
38	1	TRIPSTOP BRAKE ACTUATOR	423 000 ... 2	...
39	1	TRIPSTOP BRAKE ACTUATOR	423 000 ... 2	...
40	1	TRIPSTOP BRAKE ACTUATOR	423 000 ... 2	...
41	1	TRIPSTOP BRAKE ACTUATOR	423 000 ... 2	...
42	1	TRIPSTOP BRAKE ACTUATOR	423 000 ... 2	...
43	1	TRIPSTOP BRAKE ACTUATOR	423 000 ... 2	...
44	1	TRIPSTOP BRAKE ACTUATOR	423 000 ... 2	...
45	1	TRIPSTOP BRAKE ACTUATOR	423 000 ... 2	...
46	1	TRIPSTOP BRAKE ACTUATOR	423 000 ... 2	...
47	1	TRIPSTOP BRAKE ACTUATOR	423 000 ... 2	...
48	1	TRIPSTOP BRAKE ACTUATOR	423 000 ... 2	...
49	1	TRIPSTOP BRAKE ACTUATOR	423 000 ... 2	...
50	1	TRIPSTOP BRAKE ACTUATOR	423 000 ... 2	...
51	1	TRIPSTOP BRAKE ACTUATOR	423 000 ... 2	...
52	1	TRIPSTOP BRAKE ACTUATOR	423 000 ... 2	...
53	1	TRIPSTOP BRAKE ACTUATOR	423 000 ... 2	...
54	1	TRIPSTOP BRAKE ACTUATOR	423 000 ... 2	...
55	1	TRIPSTOP BRAKE ACTUATOR	423 000 ... 2	...
56	1	TRIPSTOP BRAKE ACTUATOR	423 000 ... 2	...
57	1	TRIPSTOP BRAKE ACTUATOR	423 000 ... 2	...
58	1	TRIPSTOP BRAKE ACTUATOR	423 000 ... 2	...
59	1	TRIPSTOP BRAKE ACTUATOR	423 000 ... 2	...
60	1	TRIPSTOP BRAKE ACTUATOR	423 000 ... 2	...
61	1	TRIPSTOP BRAKE ACTUATOR	423 000 ... 2	...
62	1	TRIPSTOP BRAKE ACTUATOR	423 000 ... 2	...
63	1	TRIPSTOP BRAKE ACTUATOR	423 000 ... 2	...
64	1	TRIPSTOP BRAKE ACTUATOR	423 000 ... 2	...
65	1	TRIPSTOP BRAKE ACTUATOR	423 000 ... 2	...
66	1	TRIPSTOP BRAKE ACTUATOR	423 000 ... 2	...
67	1	TRIPSTOP BRAKE ACTUATOR	423 000 ... 2	...
68	1	TRIPSTOP BRAKE ACTUATOR	423 000 ... 2	...
69	1	TRIPSTOP BRAKE ACTUATOR	423 000 ... 2	...
70	1	TRIPSTOP BRAKE ACTUATOR	423 000 ... 2	...
71	1	TRIPSTOP BRAKE ACTUATOR	423 000 ... 2	...
72	1	TRIPSTOP BRAKE ACTUATOR	423 000 ... 2	...
73	1	TRIPSTOP BRAKE ACTUATOR	423 000 ... 2	...
74	1	TRIPSTOP BRAKE ACTUATOR	423 000 ... 2	...
75	1	TRIPSTOP BRAKE ACTUATOR	423 000 ... 2	...
76	1	TRIPSTOP BRAKE ACTUATOR	423 000 ... 2	...
77	1	TRIPSTOP BRAKE ACTUATOR	423 000 ... 2	...
78	1	TRIPSTOP BRAKE ACTUATOR	423 000 ... 2	...
79	1	TRIPSTOP BRAKE ACTUATOR	423 000 ... 2	...
80	1	TRIPSTOP BRAKE ACTUATOR	423 000 ... 2	...
81	1	TRIPSTOP BRAKE ACTUATOR	423 000 ... 2	...
82	1	TRIPSTOP BRAKE ACTUATOR	423 000 ... 2	...
83	1	TRIPSTOP BRAKE ACTUATOR	423 000 ... 2	...
84	1	TRIPSTOP BRAKE ACTUATOR	423 000 ... 2	...
85	1	TRIPSTOP BRAKE ACTUATOR	423 000 ... 2	...
86	1	TRIPSTOP BRAKE ACTUATOR	423 000 ... 2	...
87	1	TRIPSTOP BRAKE ACTUATOR	423 000 ... 2	...
88	1	TRIPSTOP BRAKE ACTUATOR	423 000 ... 2	...
89	1	TRIPSTOP BRAKE ACTUATOR	423 000 ... 2	...
90	1	TRIPSTOP BRAKE ACTUATOR	423 000 ... 2	...
91	1	TRIPSTOP BRAKE ACTUATOR	423 000 ... 2	...
92	1	TRIPSTOP BRAKE ACTUATOR	423 000 ... 2	...
93	1	TRIPSTOP BRAKE ACTUATOR	423 000 ... 2	...
94	1	TRIPSTOP BRAKE ACTUATOR	423 000 ... 2	...
95	1	TRIPSTOP BRAKE ACTUATOR	423 000 ... 2	...
96	1	TRIPSTOP BRAKE ACTUATOR	423 000 ... 2	...
97	1	TRIPSTOP BRAKE ACTUATOR	423 000 ... 2	...
98	1	TRIPSTOP BRAKE ACTUATOR	423 000 ... 2	...
99	1	TRIPSTOP BRAKE ACTUATOR	423 000 ... 2	...
100	1	TRIPSTOP BRAKE ACTUATOR	423 000 ... 2	...

WABCO	
TRAILER - EES L	
2010 06 08	BURMESTER
POD-06-08	CHPN 5
4S/3W	BURMESTER
Det. of the order: 841 701 210 0	
841 701 210 0	002 FN 1/1
A 2	4900

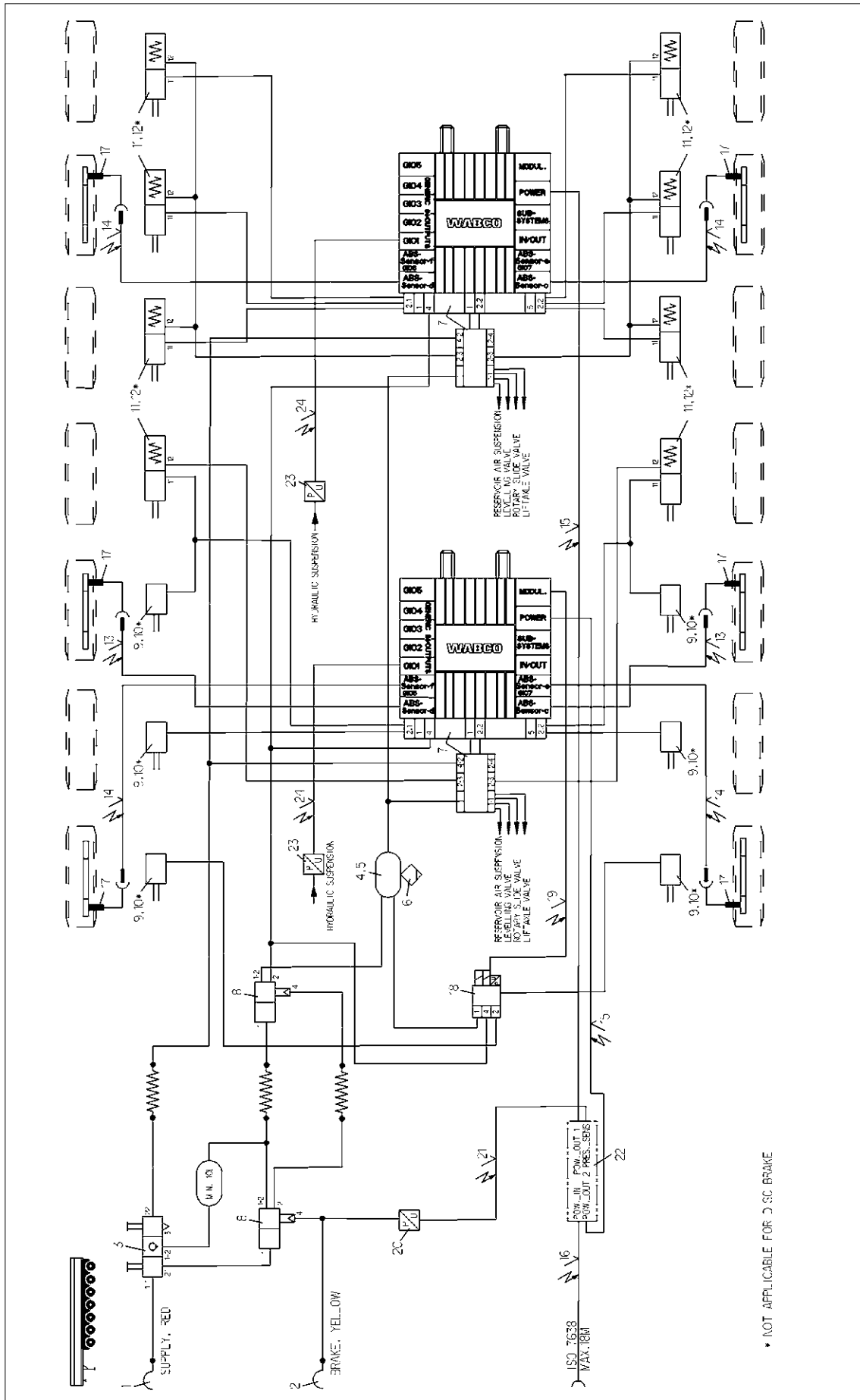

* NOT APPLICABLE FOR 3 SC BRAKE

Part No.		Description		Product Label Location No.	
12	8 KIT	449 903 532 2	1 CAR F-PRESSURE SENSOR	449 812 100 0	
11	8 INLS OF BRAKE ADJUSTER	920 C	21 2 PRESSURE SENSOR	447 0	
10	8 KIT	423 000 ... 2	22 1 COARQUETER	416 02 004 0	
9	6 BRAKE CHAMBER	425 0 ... 0	21 1 CAR F-PRESSURE SENSOR	449 425 000 0	
8	2 TRAILER EMERGENCY VALVE	971 002 301 0	20 1 PRESSURE SENSOR	447 044 101 0	
7	2 TRAILER-MODULATOR	680 103 063 0	19 1 CABLE TO ERS-RELAY VALVE	049 025 080 0	
6	1 LOBBIN VALVE	934 300 001 0	18 1 ERS-RELAY VALVE	480 207 001 0	
5	2 HOSE CLAMP	401 593 ... 2	17 6 ABS-SENSOR	447 032 809 0	
4	1 RESERVOIR	990 0	16 1 SUPPLY CAR F	449 185 ... 0	
3	1 IN-LINE VALVE	963 301 091 0	15 2 CABLE TO RES MODULATOR	449 347 000 0	
2	1 COUPLING HEAD W. 10" LIME FILTER	962 201 ... 0	14 4 EXTERIOR CABLE FOR SENSOR	449 323 ... C	
1	1 COUPLING HEAD W. 10" LIME FILTER	962 201 ... 0	13 2 EXTERIOR CABLE FOR SENSOR	449 323 ... C	
8g. 12g.	WABCO	841 701 211 0	TRAILER - EBS E	4990	

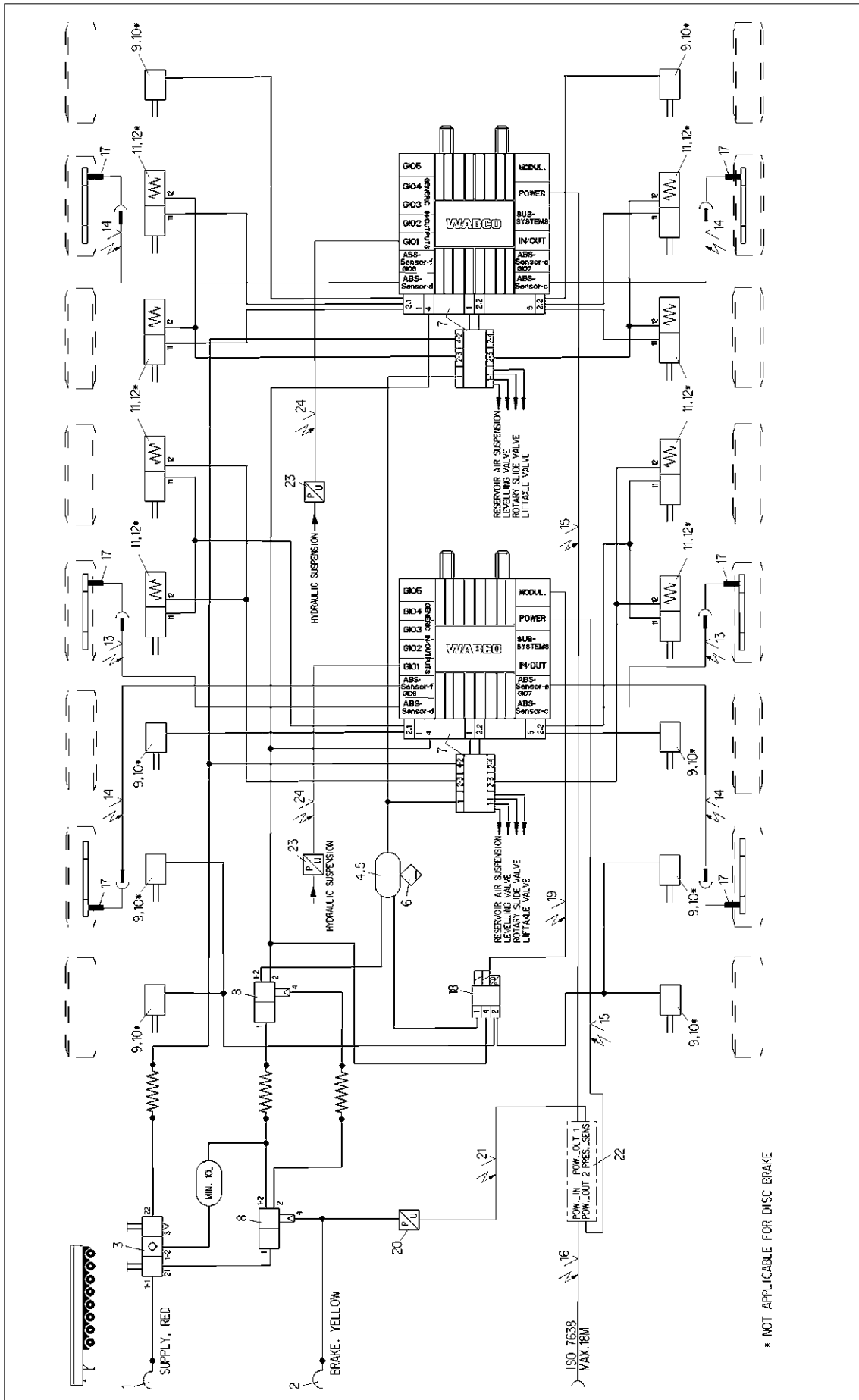

* NOT APPLICABLE FOR DISC BRAKE

WABCO
 TRAILER - EBS E
 BURKSTER
 204-0219
 204-0219
 BURKSTER

204-0219
 204-0219
 BURKSTER

FOR 8-AXLES-SEMITRAILER
 2S/2M AND 4S/2M

841 701 301 0

002 EN 1/1

A 2 Pro/E

4990

Fig. No.	Part No.	Description	Fig. No.	Part No.	Description
12	8 KIT	TRISTOP BRAKE ACTUATOR	449	812 100 0	CABLE-PRESSURE SENSOR
11	8 KIT	RESERVOIR	441
10	8 KIT	BRAKE CHAMBER	446	22 054 0	CAN-ROUTER
9	8	TRAILER EMERGENCY VALVE	449	425 000 0	CABLE-PRESSURE SENSOR
8	2	TRAILER EMERGENCY VALVE	441	044 101 0	PRESSURE SENSOR
7	2	DRAIN VALVE	449	429 080 0	CABLE TO EBS-RELAY VALVE
6	1	TRAILER EMERGENCY VALVE	441	032 806 0	EBS-RELAY VALVE
5	2	FUSE CLAMP	441	032 806 0	EBS-RELAY VALVE
4	1	RESERVOIR	449	135 ... 0	SUPPLY CABLE
3	1	RELEASE VALVE	449	347 000 0	CABLE TO EBS MODULATOR
2	1	COUPLING HEAD W. INT. LINE FILTER	449	723 ... 0	EXTENSION CABLE FOR SENSOR
1	1	COUPLING HEAD W. INT. LINE FILTER	449	723 ... 0	EXTENSION CABLE FOR SENSOR

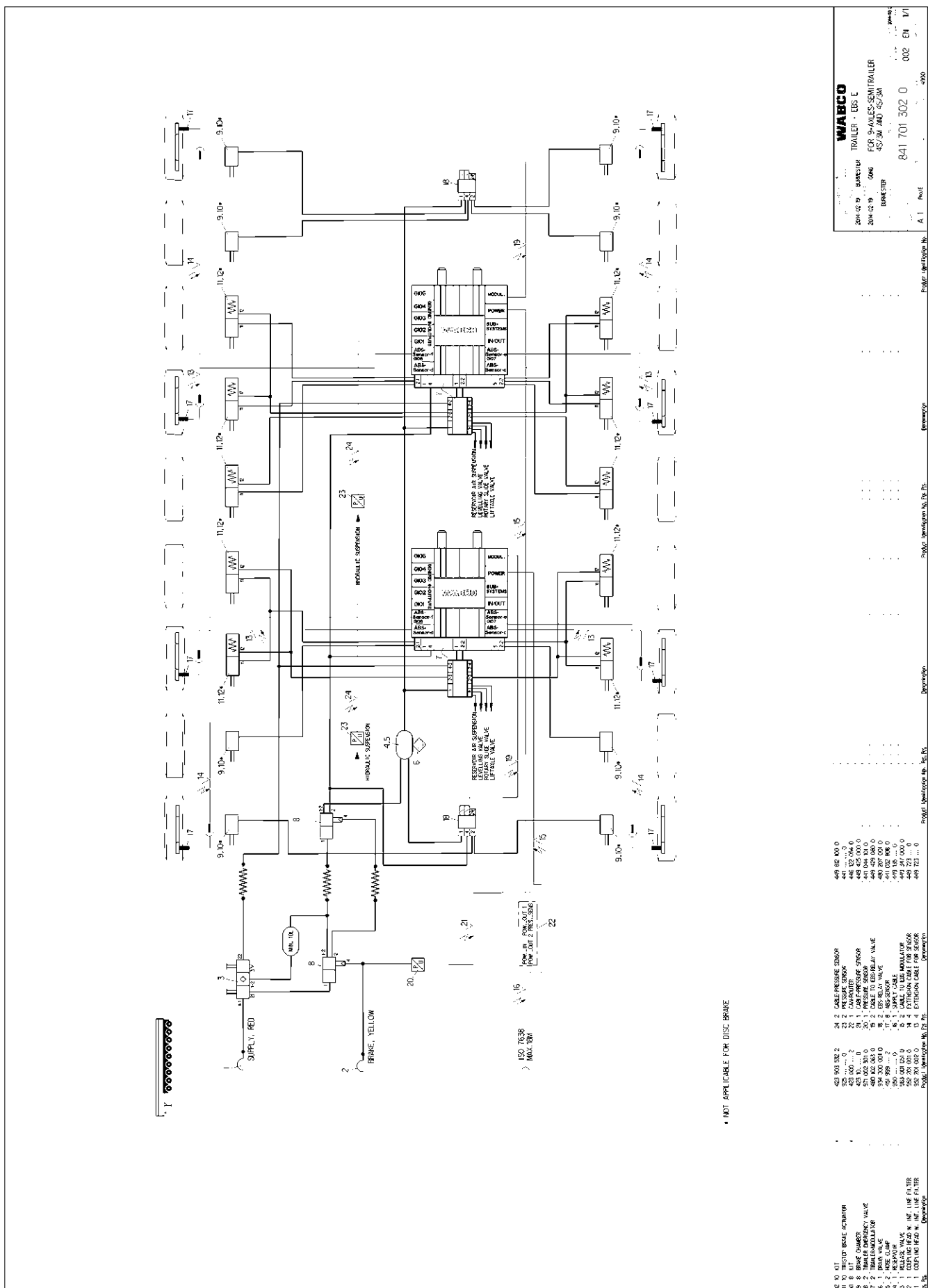

* NOT APPLICABLE FOR DISC BRAKE

WABCO
 TRAILER - EBS E
 FOR 9-AXLES-SEMI TRAILER
 4S/5M AND 4S/2M

2014-02-19 DUMKETER
 2014-02-19 0006
 DUMKETER

841 701 302 0 002 EN V1

Proj. Identification No. A.1 Proj. 5000

429 901 000	24 2	CABLE PRESSURE SENSOR	449 902 000
429 902 000	24 1	VALVE	449 903 000
429 903 000	24 1	VALVE	449 904 000
449 905 000	19 2	CABLE TO ABS RELAY VALVE	449 905 000
449 906 000	19 2	ESP-RELAY VALVE	449 907 000
449 908 000	16 1	SHUNT CABLE	449 910 000
449 911 000	13 4	EXTENSION CABLE FOR SENSOR	449 912 000
449 913 000	13 4	EXTENSION CABLE FOR SENSOR	449 914 000
449 915 000	13 4	EXTENSION CABLE FOR SENSOR	449 916 000
449 917 000	13 4	EXTENSION CABLE FOR SENSOR	449 918 000
449 919 000	13 4	EXTENSION CABLE FOR SENSOR	449 920 000
449 921 000	13 4	EXTENSION CABLE FOR SENSOR	449 922 000
449 923 000	13 4	EXTENSION CABLE FOR SENSOR	449 924 000
449 925 000	13 4	EXTENSION CABLE FOR SENSOR	449 926 000
449 927 000	13 4	EXTENSION CABLE FOR SENSOR	449 928 000
449 929 000	13 4	EXTENSION CABLE FOR SENSOR	449 930 000
449 931 000	13 4	EXTENSION CABLE FOR SENSOR	449 932 000
449 933 000	13 4	EXTENSION CABLE FOR SENSOR	449 934 000
449 935 000	13 4	EXTENSION CABLE FOR SENSOR	449 936 000
449 937 000	13 4	EXTENSION CABLE FOR SENSOR	449 938 000
449 939 000	13 4	EXTENSION CABLE FOR SENSOR	449 940 000
449 941 000	13 4	EXTENSION CABLE FOR SENSOR	449 942 000
449 943 000	13 4	EXTENSION CABLE FOR SENSOR	449 944 000
449 945 000	13 4	EXTENSION CABLE FOR SENSOR	449 946 000
449 947 000	13 4	EXTENSION CABLE FOR SENSOR	449 948 000
449 949 000	13 4	EXTENSION CABLE FOR SENSOR	449 950 000
449 951 000	13 4	EXTENSION CABLE FOR SENSOR	449 952 000
449 953 000	13 4	EXTENSION CABLE FOR SENSOR	449 954 000
449 955 000	13 4	EXTENSION CABLE FOR SENSOR	449 956 000
449 957 000	13 4	EXTENSION CABLE FOR SENSOR	449 958 000
449 959 000	13 4	EXTENSION CABLE FOR SENSOR	449 960 000
449 961 000	13 4	EXTENSION CABLE FOR SENSOR	449 962 000
449 963 000	13 4	EXTENSION CABLE FOR SENSOR	449 964 000
449 965 000	13 4	EXTENSION CABLE FOR SENSOR	449 966 000
449 967 000	13 4	EXTENSION CABLE FOR SENSOR	449 968 000
449 969 000	13 4	EXTENSION CABLE FOR SENSOR	449 970 000
449 971 000	13 4	EXTENSION CABLE FOR SENSOR	449 972 000
449 973 000	13 4	EXTENSION CABLE FOR SENSOR	449 974 000
449 975 000	13 4	EXTENSION CABLE FOR SENSOR	449 976 000
449 977 000	13 4	EXTENSION CABLE FOR SENSOR	449 978 000
449 979 000	13 4	EXTENSION CABLE FOR SENSOR	449 980 000
449 981 000	13 4	EXTENSION CABLE FOR SENSOR	449 982 000
449 983 000	13 4	EXTENSION CABLE FOR SENSOR	449 984 000
449 985 000	13 4	EXTENSION CABLE FOR SENSOR	449 986 000
449 987 000	13 4	EXTENSION CABLE FOR SENSOR	449 988 000
449 989 000	13 4	EXTENSION CABLE FOR SENSOR	449 990 000
449 991 000	13 4	EXTENSION CABLE FOR SENSOR	449 992 000
449 993 000	13 4	EXTENSION CABLE FOR SENSOR	449 994 000
449 995 000	13 4	EXTENSION CABLE FOR SENSOR	449 996 000
449 997 000	13 4	EXTENSION CABLE FOR SENSOR	449 998 000
449 999 000	13 4	EXTENSION CABLE FOR SENSOR	449 1000 000

2.2 Central axle trailer

AXLE(S)	ABS SYSTEM	NUMBER	TRISTOP™	OVERLOAD PROTECTION VALVE	PEM	MECHANICAL SUSPENSION	ADDITIONAL TRAILER	PREV	COMMENT	PAGE
1	2S/2M	841 601 290 0	x		x			x		163
2	4S/2M 2S/2M	841 601 280 0	x		x			x		164
2	4S/3M	841 601 281 0	x	x		x		x	VB unit	165
2	4S/2M 2S/2M	841 601 282 0	x	x				x		166
2	4S/2M 2S/2M	841 601 283 0	x				x	x	Dolly	167
2	4S/2M 2S/2M	841 601 284 0	x					x	4x Tristop™	168
2	4S/2M 2S/2M	841 601 285 0	x				x	x	Dolly / hydraulic suspension	169
2	4S/2M 2S/2M	841 601 286 0	x	x			x	x	Dolly	170
2	4S/2M 2S/2M	841 601 287 0	x		x		x	x	Dolly CAN router	171
2	4S/2M 2S/2M	841 601 288 0				x				172
2	4S/2M 2S/2M	841 601 289 0	x	x				x	Auxiliary relay / optionally RSS	173
2	4S/2M 2S/2M	841 601 320 0	x	x			x	x	Dolly CAN router	174
2	4S/3M	841 601 322 0	x		x			x	4x Tristop™	175
2	4S/3M	841 601 323 0	x		x			x		176
2	2S/2M	841 601 324 0	x	x				x	Hydraulic suspension	177
2	4S/2M 2S/2M	841 601 325 0								178
2	4S/2M 2S/2M	841 601 326 0	x	x				x	4x Tristop™	179
2	4S/2M 2S/2M	841 601 327 0	x		x	x		x		180
2	4S/3M	841 601 328 0	x	x		x		x	VB unit / 4x Tristop™	181
2	4S/3M	841 601 329 0	x	x		x		x	W unit / 4x Tristop™	182
2	4S/3M	841 601 392 0				x			VB unit	183
3	4S/2M 2S/2M	841 601 300 0	x		x			x		184
3	4S/2M 2S/2M	841 601 301 0	x	x				x		185
3	4S/2M 2S/2M	841 601 302 0							Hydraulic suspension / Multi-Voltage	186
3	2S/2M	841 601 303 0	x	x				x	Hydraulic suspension	187
3	4S/2M 2S/2M	841 601 304 0	x	x				x	Hydraulic suspension / Multi-Voltage	188

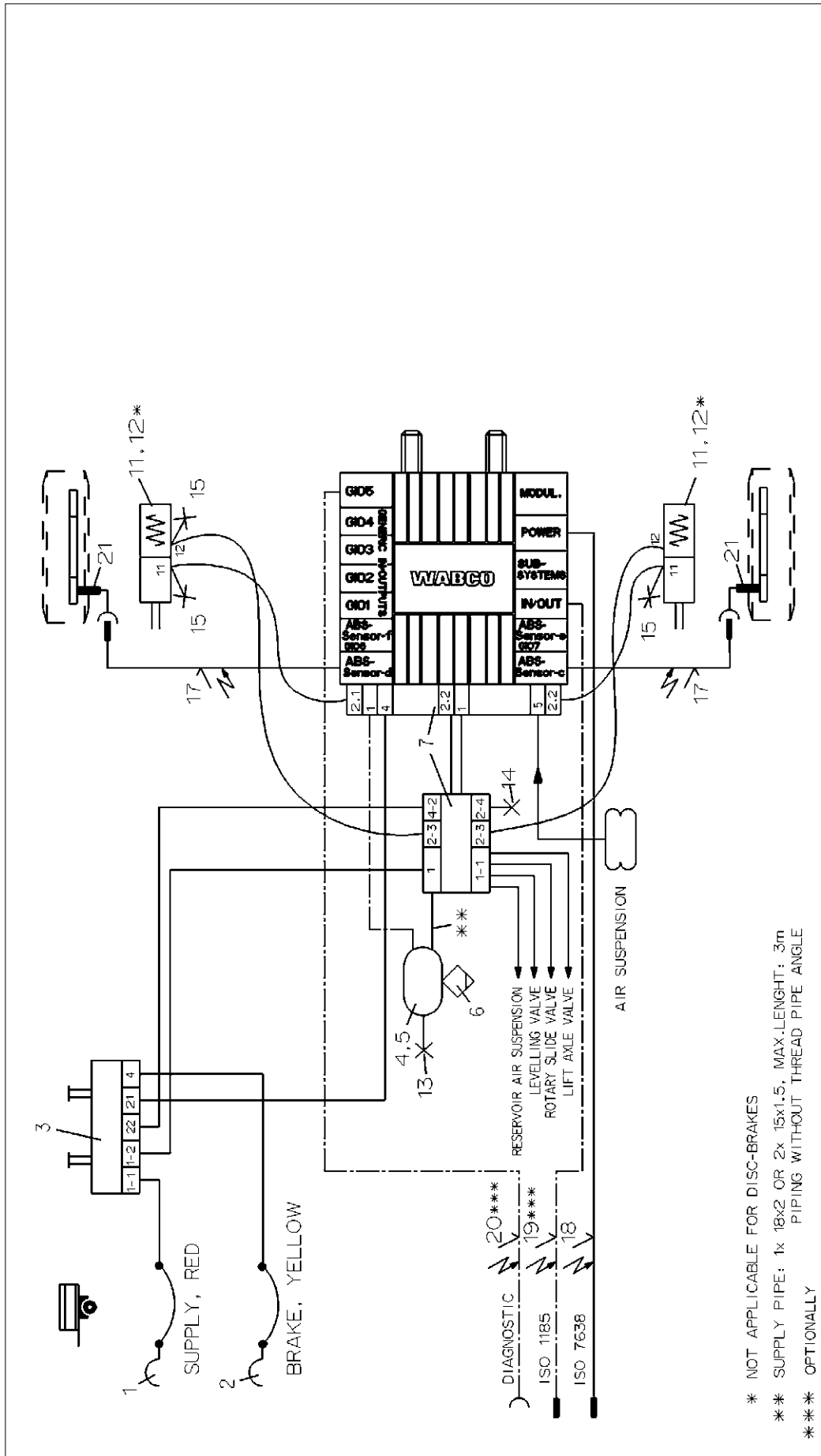

12	2	KIT	423 903 532 2							Signal line		
11	2	TRISTOP BRAKE ACTUATOR	925 ... 0			2008-09-30	BURMESTER			2008-09-30		
10										2008-09-30		
9										2008-09-30		
8										2008-09-30		
7	1	TRAILER-MODULATOR W. EXTENSION MODUL	480 102 ... 0		***	441 032 8... 0	BURMESTER			2008-09-30		
6	1	DRAIN VALVE	934 300 001 0		***	449 611 ... 0	CHRONIS			2008-09-30		
5	2	HOSE CLAMP	451 999 ... 2			449 349 ... 0	BURMESTER			2008-09-30		
4	1	AIR RESERVOIR	950 ... 0			449 273 ... 0	BURMESTER			2008-09-30		
3	1	PARK-RELEASE-EMERGENCY VALVE	971 002 9... 0			449 723 ... 0	BURMESTER			2008-09-30		
2	1	COUPLING HEAD W. INT. LINE FILTER	952 201 ... 0			463 703 036 0				2008-09-30		
1	1	COUPLING HEAD W. INT. LINE FILTER	952 201 ... 0			463 703 120 0				2008-09-30		
1	1	COUPLING HEAD W. INT. LINE FILTER	952 201 ... 0			463 703 115 0				2008-09-30		
Denomination				Product Identification No.	Pos./Pcs.				Date of first issue: 2008-09-30			
Denomination				Product Identification No.	Pos./Pcs.				Date of first issue: 2008-09-30			
Denomination				Product Identification No.	Pos./Pcs.				Date of first issue: 2008-09-30			
Denomination				Product Identification No.	Pos./Pcs.				Date of first issue: 2008-09-30			
Denomination				Product Identification No.	Pos./Pcs.				Date of first issue: 2008-09-30			
Denomination				Product Identification No.	Pos./Pcs.				Date of first issue: 2008-09-30			

WABCO

TRAILER - EBS E

FOR 1-AXLE- CENTRAL-AXLE-TRAILER

2S/2M

-PENT-

841 601 290 0

002 EN 1/1

4990

* NOT APPLICABLE FOR DISC-BRAKES
 ** SUPPLY PIPE: 1x 18x2 OR 2x 15x1,5, MAX. LENGTH: 3m
 PIPING WITHOUT THREAD PIPE ANGLE
 *** OPTIONALLY

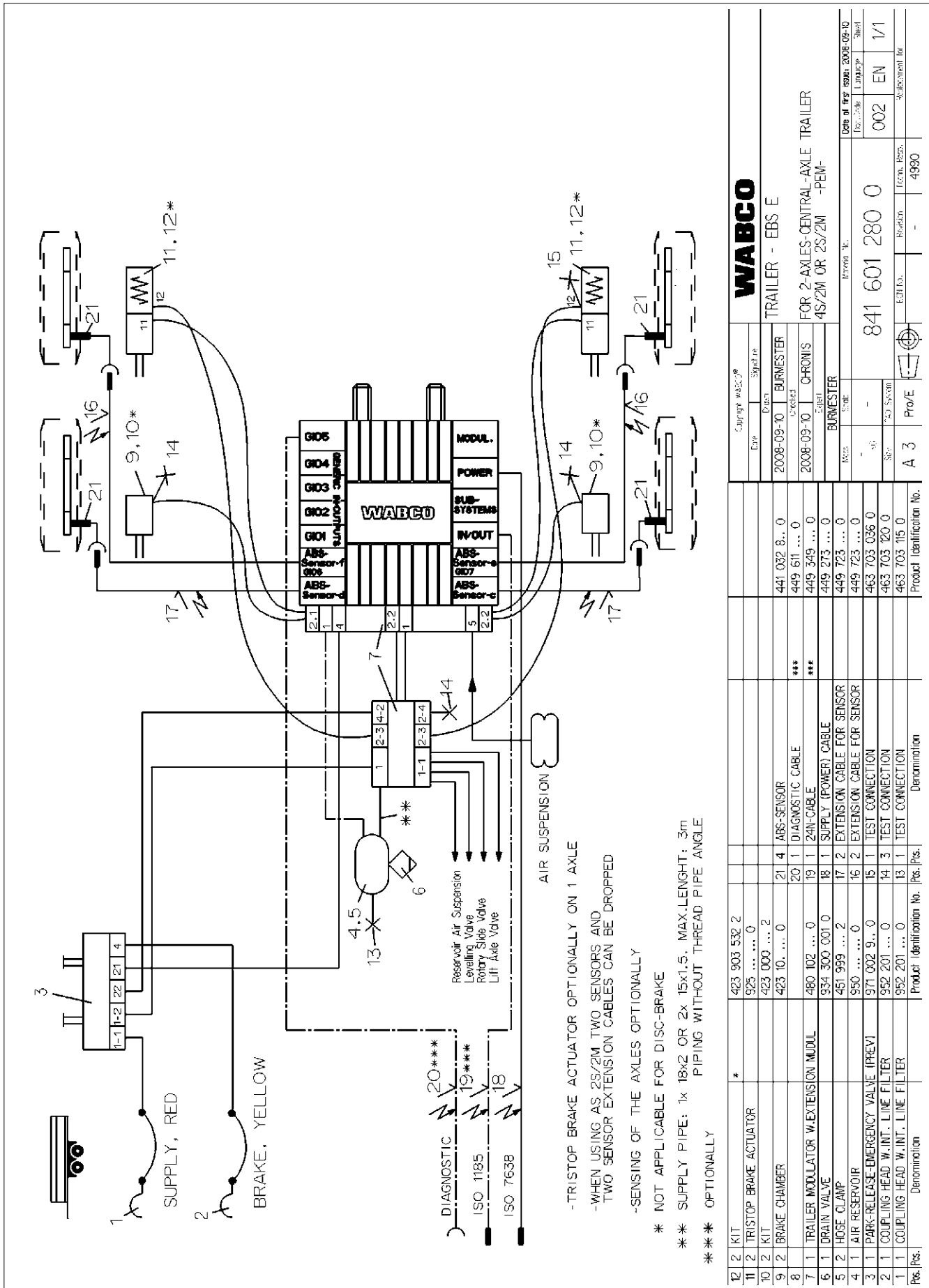

Copyright WABCO		WABCO	
Drawn	Checked	Project	Sheet
2008-09-10	BURMESTER	TRAILER - EBS E	002
2008-09-10	CHRONIS	FOR 2-AXLES-CENTRAL-AXLE TRAILER	EN 1/1
2008-09-10	BURMESTER	4S/2M OR 2S/2M -PEM-	
Part No.	841 601 280 0	Revision	4990
Product Identification No.	A 3	Pro/E	
Product Identification No.	463 903 532 2	Denomination	
11 2	TRISTOP BRAKE ACTUATOR	925 0	
10 2	KIT	423 000 ... 2	
9 2	BRAKE CHAMBER	423 10 ... 0	
8	TRAILER MODULATOR W/EXTENSION MODUL	21 4 ABS-SENSOR	441 032 8.. 0
7 1	BRAIN VALVE	20 1 DIAGNOSTIC CABLE	449 611 ... 0
6 1	HOSE CLAMP	19 1 24N-CABLE	449 349 ... 0
5 2	AIR RESERVOIR	18 1 SUPPLY (POWER) CABLE	449 273 ... 0
4 1	PARK-RELEASE-EMERGENCY VALVE (PREV)	17 2 EXTENSION CABLE FOR SENSOR	449 723 ... 0
3 1	COUPLING HEAD W.INT. LINE FILTER	16 2 EXTENSION CABLE FOR SENSOR	463 703 036 0
2 1	COUPLING HEAD W.INT. LINE FILTER	15 1 TEST CONNECTION	463 703 120 0
1 1	COUPLING HEAD W.INT. LINE FILTER	14 3 TEST CONNECTION	463 703 115 0

841 601 281 0

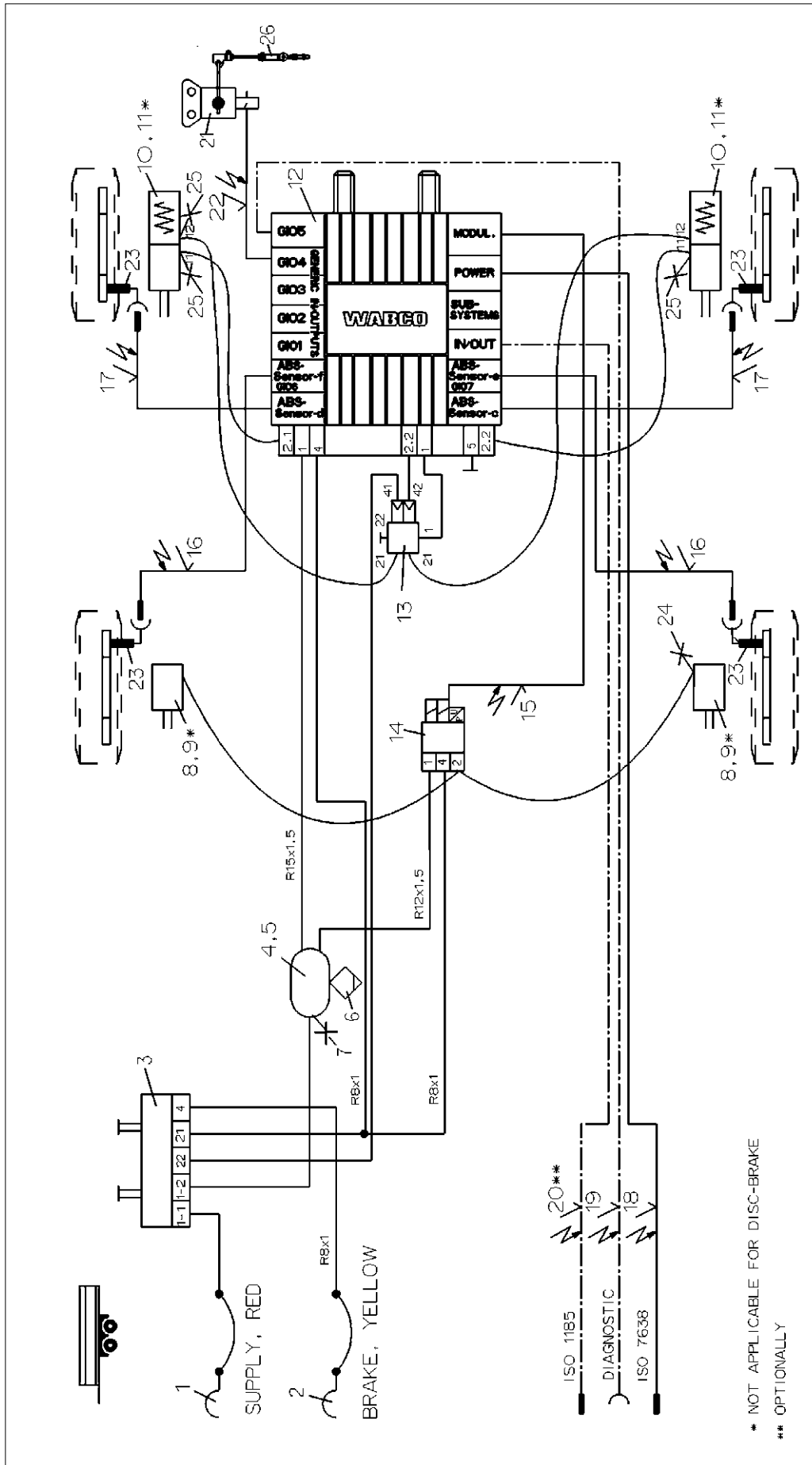

* NOT APPLICABLE FOR DISC-BRAKE
 ** OPTIONALLY

Part No.	Description	Qty.	Part No.	Description	Qty.	Part No.	Description	Qty.
13	1 OVERLOAD-PROTECTION-RV	1	973 011 201 0	LINKAGE	1	433 401 003 0		
12	1 TRAILER-MODULATOR	3	460 102 ... 0	TEST CONNECTION	0	463 703 036 0		
11	2 KIT	1	423 903 532 2	TEST CONNECTION	0	463 703 120 0		
10	2 TRISTOP BRAKE ACTUATOR	4	925 0	ABS-SENSOR	0	441 0		
9	2 KIT	2	423 2	GIO-CABLE-DISTANCE SENSOR	0	449 811 ... 0		
8	2 BRAKE CHAMBER	1	423 0	DISTANCE SENSOR	0	441 050 100 0		
7	1 TEST CONNECTION	0	463 703 ... 0	24-IN-CABLE	0	449 349 ... 0		
6	1 DRAIN VALVE	0	934 300 001 0	DIAGNOSTIC CABLE	0	449 611 ... 0		
5	1 HOSE Q-AMP	2	451 999 ... 2	SUPPLY (POWER) CABLE	0	449 273 ... 0		
4	1 AIR RESERVOIR	0	950 0	EXTENSION CABLE FOR SENSOR	0	449 723 ... 0		
3	1 PARK-RELEASE-EMERGENCY VALVE (PREV)	0	971 002 9... 0	EXTENSION CABLE FOR SENSOR	0	449 723 ... 0		
2	1 COUPLING HEAD W/INT.LINE FILTER	0	952 201 ... 0	CABLE TO EBS-RV	0	449 429 ... 0		
1	1 COUPLING HEAD W/INT.LINE FILTER	0	952 201 ... 0	EBS-RELAY VALVE	0	480 207 0... 0		

WABCO TRAILER - EBS E FOR 2-AXLES-CENTRAL-AXLE TRAILER 4S/3M WITH RSS, VB-AGGREGATE MECH. SUSPENSION <small>(Material No.)</small>		Date of first issue: 2008-09-15 Doc. code: 1044079 Page:	
City: Burmester Name: Burmester Checked: 2008-09-15 Date: 2008-09-15 Sign.: Burmester Title:	Part No.: 841 601 281 0 Equip. No.: Equip. Year: 4990 Pro/E: A 3	Part No.: 841 601 281 0 Equip. No.: Equip. Year: 4990	Date of first issue: 2008-09-15 Doc. code: 1044079 Page:

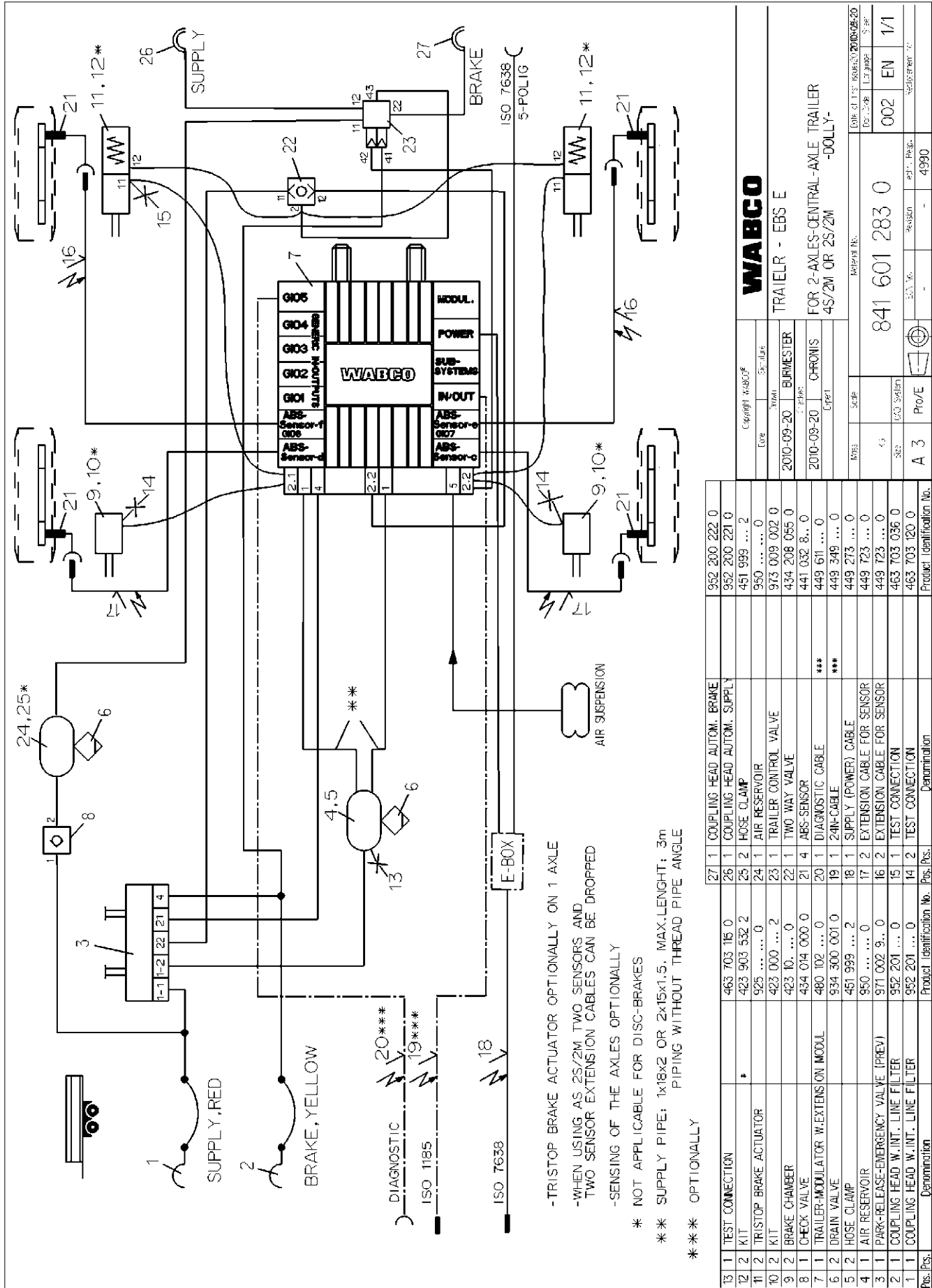

- TRISTOP BRAKE ACTUATOR OPTIONALLY ON 1 AXLE
 - WHEN USING AS 2S/2M TWO SENSORS AND TWO SENSOR EXTENSION CABLES CAN BE DROPPED
 - SENSING OF THE AXLES OPTIONALLY
 * NOT APPLICABLE FOR DISC-BRAKES
 ** SUPPLY PIPE: 1x18x2 OR 2x15x1.5, MAX-LENGTH: 3m PIPING WITHOUT THREAD PIPE ANGLE
 *** OPTIONALLY

Pos. Pos.	Denomination	Product identification No.	Pos. Pos.	Denomination	Product identification No.
13 1	TEST CONNECTION	463 703 115 0	27 1	COUPLING HEAD AUTOM. BRAKE	952 200 222 0
12 2	KIT	423 903 532 2	26 1	COUPLING HEAD AUTOM. SUPPLY	952 200 221 0
11 2	TRISTOP BRAKE ACTUATOR	925 0	25 2	HOSE CLAMP	451 993 ... 2
10 2	KIT	423 000 ... 2	24 1	AIR RESERVOIR	973 009 002 0
9 2	BRAKE CHAMBER	423 10 ... 0	23 1	TRAILER CONTROL VALVE	434 208 055 0
8 2	CHECK VALVE	434 014 000 0	22 1	TWO-WAY VALVE	441 032 8... 0
7 1	TRAILER-MODULATOR W.EXTENSION MODUL	480 102 ... 0	21 4	ABS-SENSOR	449 611 ... 0
6 2	DRAIN VALVE	934 300 001 0	20 1	DIAGNOSTIC CABLE	449 349 ... 0
5 2	HOSE CLAMP	451 999 ... 2	19 1	24M-CABLE	449 273 ... 0
4 1	AIR RESERVOIR	950 0	18 1	SUPPLY (POWER) CABLE	449 723 ... 0
3 1	PARK-RELEASE-EMERGENCY VALVE (PREV)	971 002 9... 0	17 2	EXTENSION CABLE FOR SENSOR	449 723 ... 0
2 1	COUPLING HEAD W. INT. LINE FILTER	952 201 ... 0	16 2	EXTENSION CABLE FOR SENSOR	449 723 ... 0
1 1	COUPLING HEAD W. INT. LINE FILTER	952 201 ... 0	15 1	TEST CONNECTION	463 703 036 0
			14 2	TEST CONNECTION	463 703 120 0

WABCO
 TRAILER - EBS E
 FOR 2-AXLES-CENTRAL-AXLE TRAILER
 4S/2M OR 2S/2M -DOLLY-

Material No. 841 601 283 0
 Date 2008 10 06
 Scale 1:1
 Part. No. 002 EN 1/1
 Revision -
 ECU No. -
 Pro/E 4990

841 601 284 0

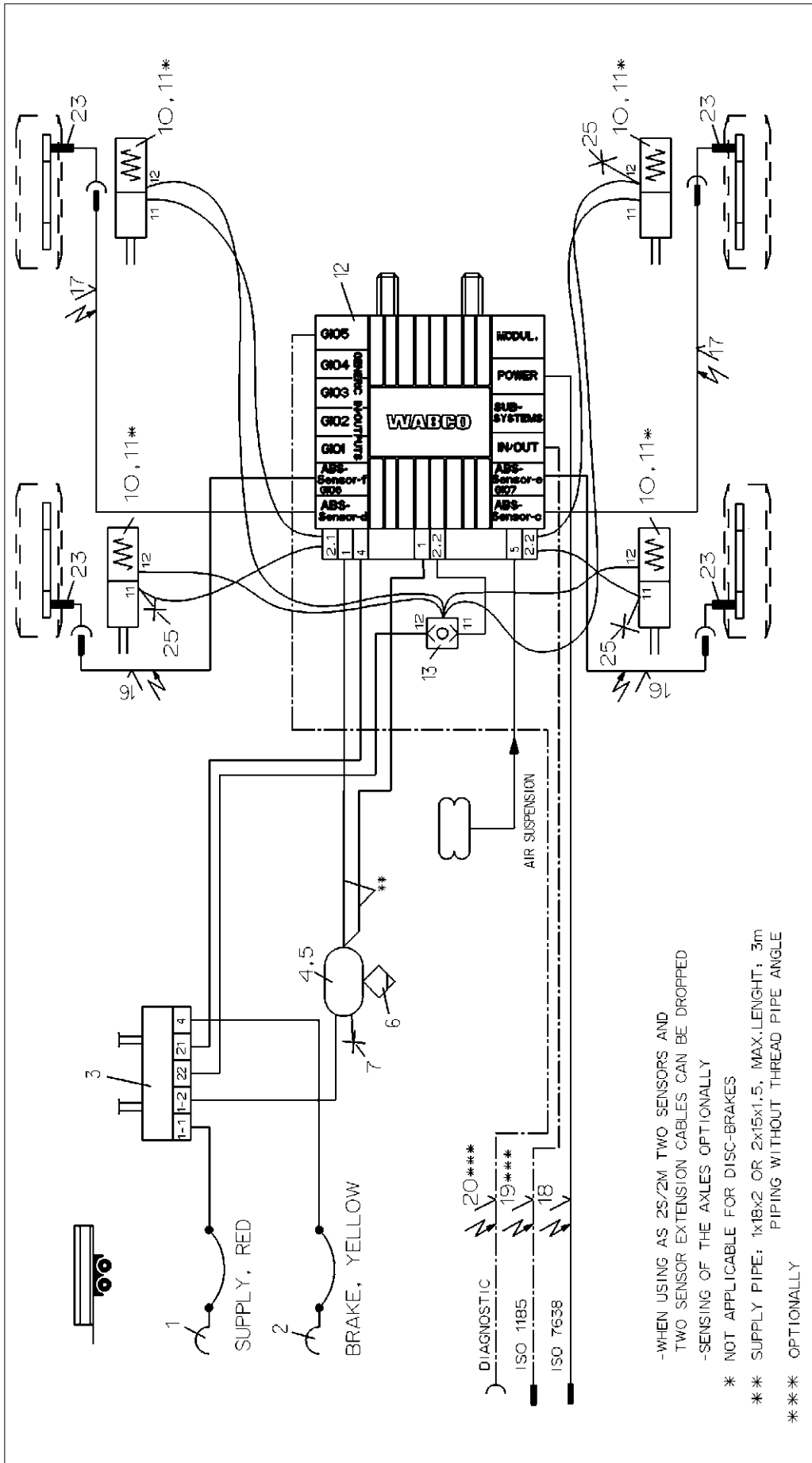

-WHEN USING AS 2S/2M TWO SENSORS AND TWO SENSOR EXTENSION CABLES CAN BE DROPPED
 -SENSING OF THE AXLES OPTIONALLY
 * NOT APPLICABLE FOR DISC-BRAKES
 ** SUPPLY PIPE: 1x18x2 OR 2x15x1.5, MAX. LENGTH: 3m
 PIPING WITHOUT THREAD PIPE ANGLE
 *** OPTIONALLY

WABCO																								
TRAILER - EBS E																								
FOR 2-AXLES-CENTRAL-AXLE TRAILER 2S/2M OR 4S/2M , OPTIONALLY RSS																								
<table border="1"> <tr> <th colspan="2">Type</th> <th>Year</th> <th>Symbol</th> </tr> <tr> <td>2008-09-16</td> <td>BURMESTER</td> <td></td> <td></td> </tr> <tr> <td colspan="4" style="text-align: center;">TRAILER</td> </tr> <tr> <td>2008-09-16</td> <td>CHRONIS</td> <td></td> <td></td> </tr> <tr> <td colspan="4" style="text-align: center;">BURMESTER</td> </tr> </table>					Type		Year	Symbol	2008-09-16	BURMESTER			TRAILER				2008-09-16	CHRONIS			BURMESTER			
Type		Year	Symbol																					
2008-09-16	BURMESTER																							
TRAILER																								
2008-09-16	CHRONIS																							
BURMESTER																								
<table border="1"> <tr> <td colspan="4">Date of first issue: 2008-09-16</td> </tr> <tr> <td>Doc.No.</td> <td>Lat. page</td> <td colspan="2">Sheet</td> </tr> <tr> <td>841 601 284 0</td> <td>002</td> <td colspan="2">EN 1/1</td> </tr> </table>					Date of first issue: 2008-09-16				Doc.No.	Lat. page	Sheet		841 601 284 0	002	EN 1/1									
Date of first issue: 2008-09-16																								
Doc.No.	Lat. page	Sheet																						
841 601 284 0	002	EN 1/1																						
<table border="1"> <tr> <td>Part. No.</td> <td>Revised</td> <td>Rev. No.</td> <td>Rev. Pass.</td> <td>Author</td> </tr> <tr> <td>A 3</td> <td>Pro/E</td> <td>-</td> <td>4990</td> <td></td> </tr> </table>					Part. No.	Revised	Rev. No.	Rev. Pass.	Author	A 3	Pro/E	-	4990											
Part. No.	Revised	Rev. No.	Rev. Pass.	Author																				
A 3	Pro/E	-	4990																					
Product Identification No.																								
13	1	2-WAY VALVE	434 208 055 0	Pos. Pos.																				
12	1	TRAILER-MODULATOR	480 102 ... 0																					
11	4	KIT	423 903 532 2																					
10	4	TRISTOP BRAKE ACTUATOR	925 0																					
9																								
8																								
7	1	TEST CONNECTION	463 703 115 0																					
6	1	DRAIN VALVE	934 300 001 0																					
5	2	HOSE CLAMP	451 999 ... 2																					
4	1	AIR RESERVOIR	950 0																					
3	1	PARK-RELEASE-EMERGENCY VALVE (PREV)	971 002 9... 0																					
2	1	COUPLING HEAD W.INT. LINE FILTER	952 201 ... 0																					
1	1	COUPLING HEAD W.INT. LINE FILTER	952 201 ... 0																					
Denomination		Denomination																						

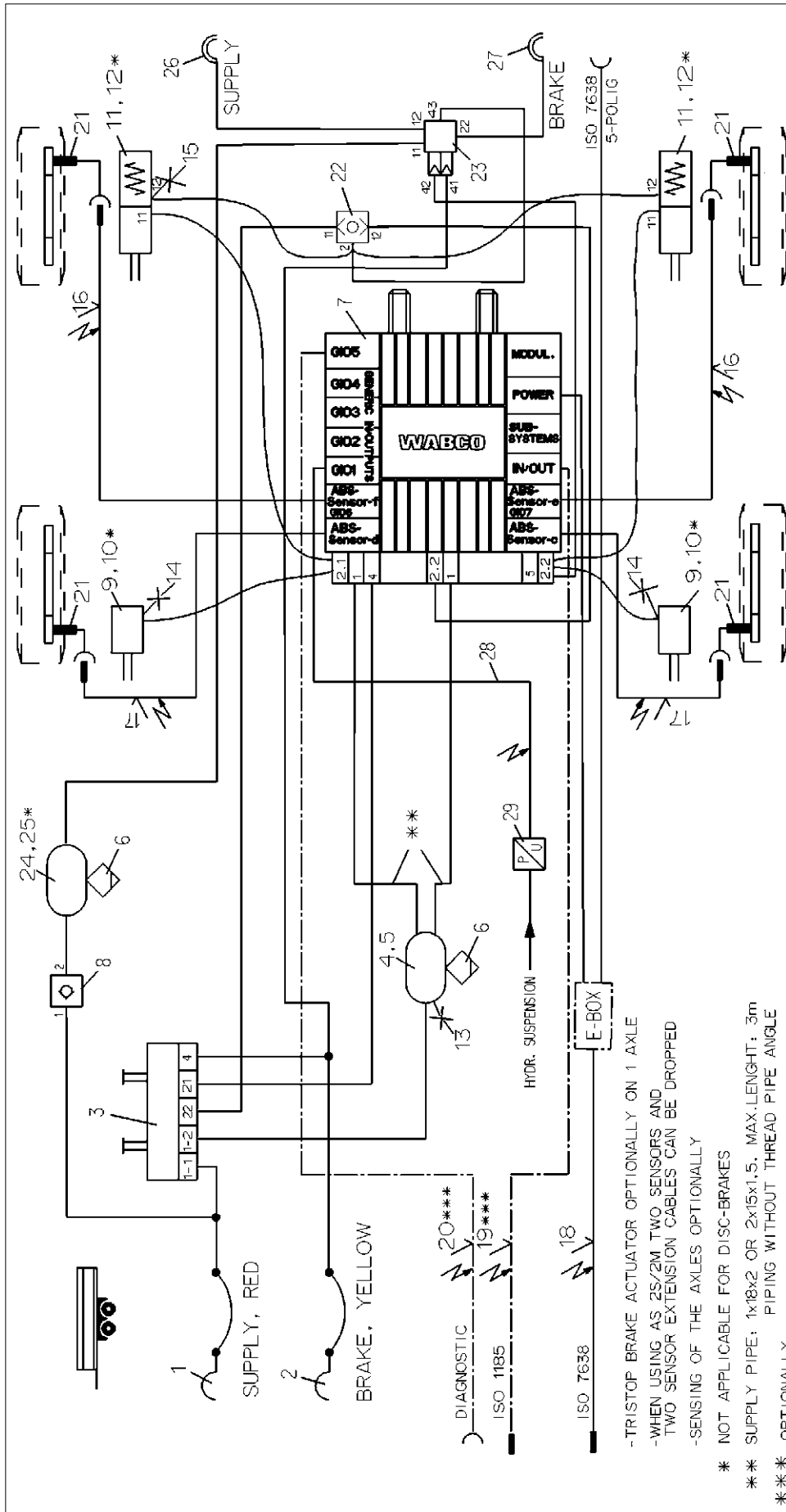

- TRISTOP BRAKE ACTUATOR OPTIONAL ON 1 AXLE
 - WHEN USING AS 2S/2M TWO SENSORS AND TWO SENSOR EXTENSION CABLES CAN BE DROPPED
 - SENSING OF THE AXLES OPTIONALLY
 * NOT APPLICABLE FOR DISC-BRAKES
 ** SUPPLY PIPE; 1x18x2 OR 2x15x1,5, MAX.LENGTH: 3m PIPING WITHOUT THREAD PIPE ANGLE
 *** OPTIONALLY

Pos./Pos.	Denomination	Product Identification No.	Pos./Pos.	Denomination	Product Identification No.
15 1	TEST CONNECTION	463 703 036 0	29 1	PRESSURE SENSOR	...
14 2	TEST CONNECTION	463 703 120 0	28 1	CABLE-PRESSURE SENSOR	449 812 ... 0
13 1	TEST CONNECTION	463 703 115 0	27 1	COUPLING HEAD AUTOM. BRAKE	952 200 222 0
12 2	KIT	423 903 532 2	26 1	COUPLING HEAD AUTOM. SUPPLY	952 200 221 0
11 2	TRISTOP BRAKE ACTUATOR	925 ... 0	25 2	HOSE CLAMP	451 989 ... 2
10 2	KIT	423 000 ... 0	24 1	AIR RESERVOIR	950 ... 0
9 1	BRAKE CHAMBER	423 10 ... 0	23 1	TRAILER CONTROL VALVE	973 009 002 0
8 1	CHECK VALVE	434 014 000 0	22 1	TWO WAY VALVE	434 208 055 0
7 1	TRAILER-MODULATOR W.EXTENSION MODUL.	490 702 ... 0	21 4	ABS-SENSOR	441 032 8... 0
6 2	DRAIN VALVE	934 300 001 0	20 1	DIAGNOSTIC CABLE	449 611 ... 0
5 2	HOSE CLAMP	451 999 ... 2	19 1	24IN-CABLE	449 349 ... 0
4 1	AIR RESERVOIR	950 ... 0	18 1	SUPPLY (POWER) CABLE	449 273 ... 0
3 1	PARK-RELEASE-EMERGENCY VALVE	971 002 9... 0	17 2	EXTENSION CABLE FOR SENSOR	449 723 ... 0
2 1	COUPLING HEAD W.INT. LINE FILTER	952 201 ... 0	16 2	EXTENSION CABLE FOR SENSOR	449 723 ... 0
1 1	COUPLING HEAD W.INT. LINE FILTER	952 201 ... 0			

WABCO	
TRAILER - EBS E	
FOR 2-AXLES-CENTRAL-AXLE-TRAILER 4S/2M OR 2S/2M -DOLLY-	
Part No.	841 601 285 0
Rev. No.	002
Ed. No.	EN
Year	1/1
Material No.	
Technical Drawing	4990

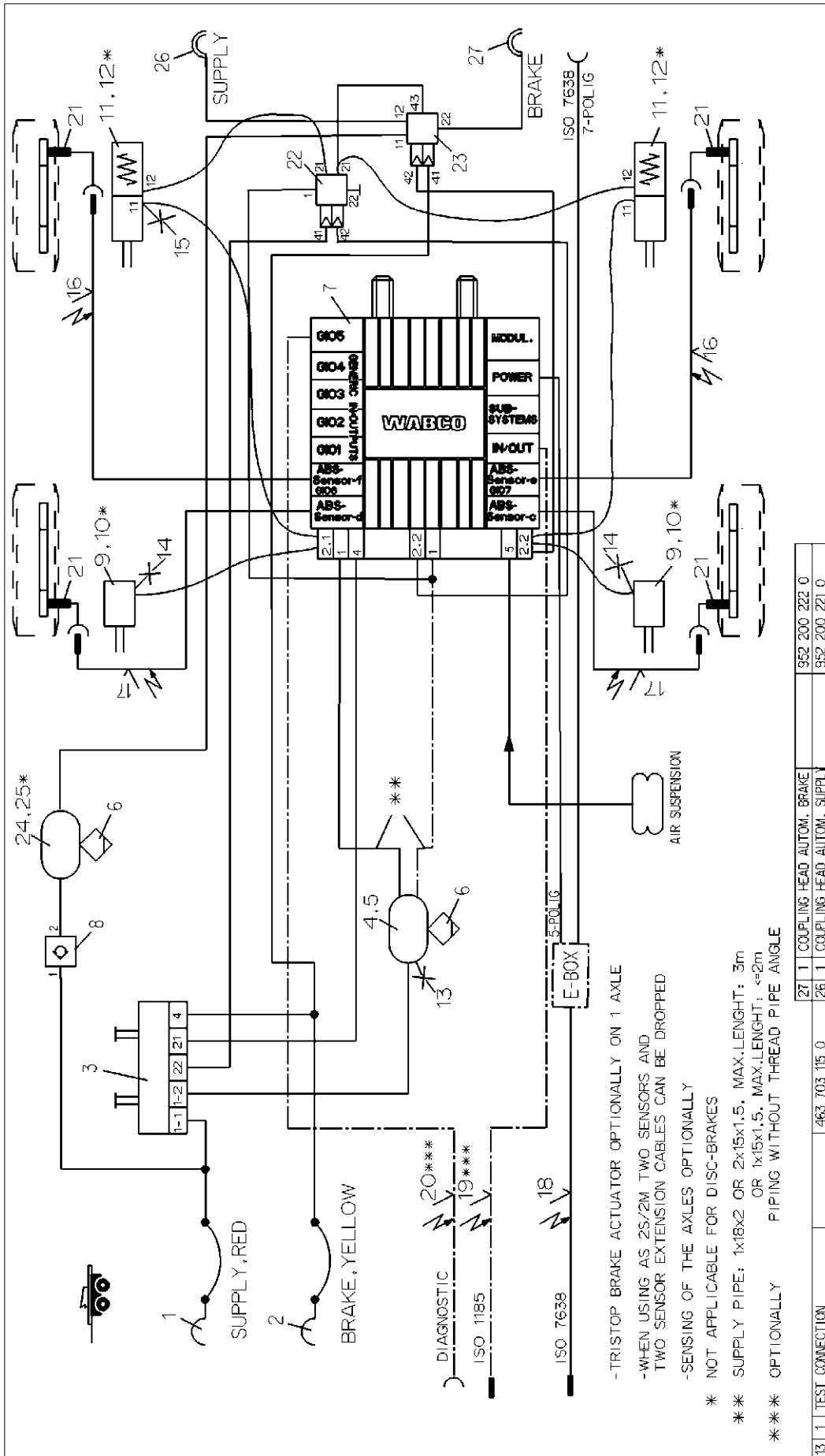

2-way WABCO		3-way WABCO	
Cuts	Signals	Trains	Diagnosis
2010-09-20	BURMESTER	2010-09-20	BURMESTER
2010-09-20	CHRONIS	2010-09-20	CHRONIS
WABCO No. 841 601 286 0			
Date of first issue: 2010-09-20			
Date of last issue: 2010-09-20			
Represent. Int. 002 EN 1/1			
E.ON No. - - - - -			
Part. Reg. - - - - -			
4990			

Pos. Nos.	Denomination	Pos. Nos.	Denomination
13 1	TEST CONNECTION	27 1	COUPLING HEAD AUTOM. BRAKE
12 2	KIT	26 1	COUPLING HEAD AUTOM. SUPPLY
11 2	TRISTOP BRAKE ACTUATOR	25 2	HOSE CLAMP
10 2	KIT	24 1	AIR RESERVOIR
9 2	BRAKE CHAMBER	23 1	TRAILER CONTROL VALVE
8 1	CHECK VALVE	22 1	OVERLOAD-PROTECTION-RV
7 1	TRAILER-MODULATOR W. EXTENSION MODUL	21 4	ABS-SENSOR
6 2	DRAIN VALVE	20 1	DIAGNOSTIC CABLE
5 2	HOSE CLAMP	19 1	24W-CABLE
4 1	AIR RESERVOIR	18 1	SUPPLY (POWER) CABLE
3 1	PARK-RELEASE-EMERGENCY VALVE (PREV)	17 2	EXTENSION CABLE FOR SENSOR
2 1	COUPLING HEAD W. INT. LINE FILTER	16 2	EXTENSION CABLE FOR SENSOR
1 1	COUPLING HEAD W. INT. LINE FILTER	15 1	TEST CONNECTION
		14 2	TEST CONNECTION

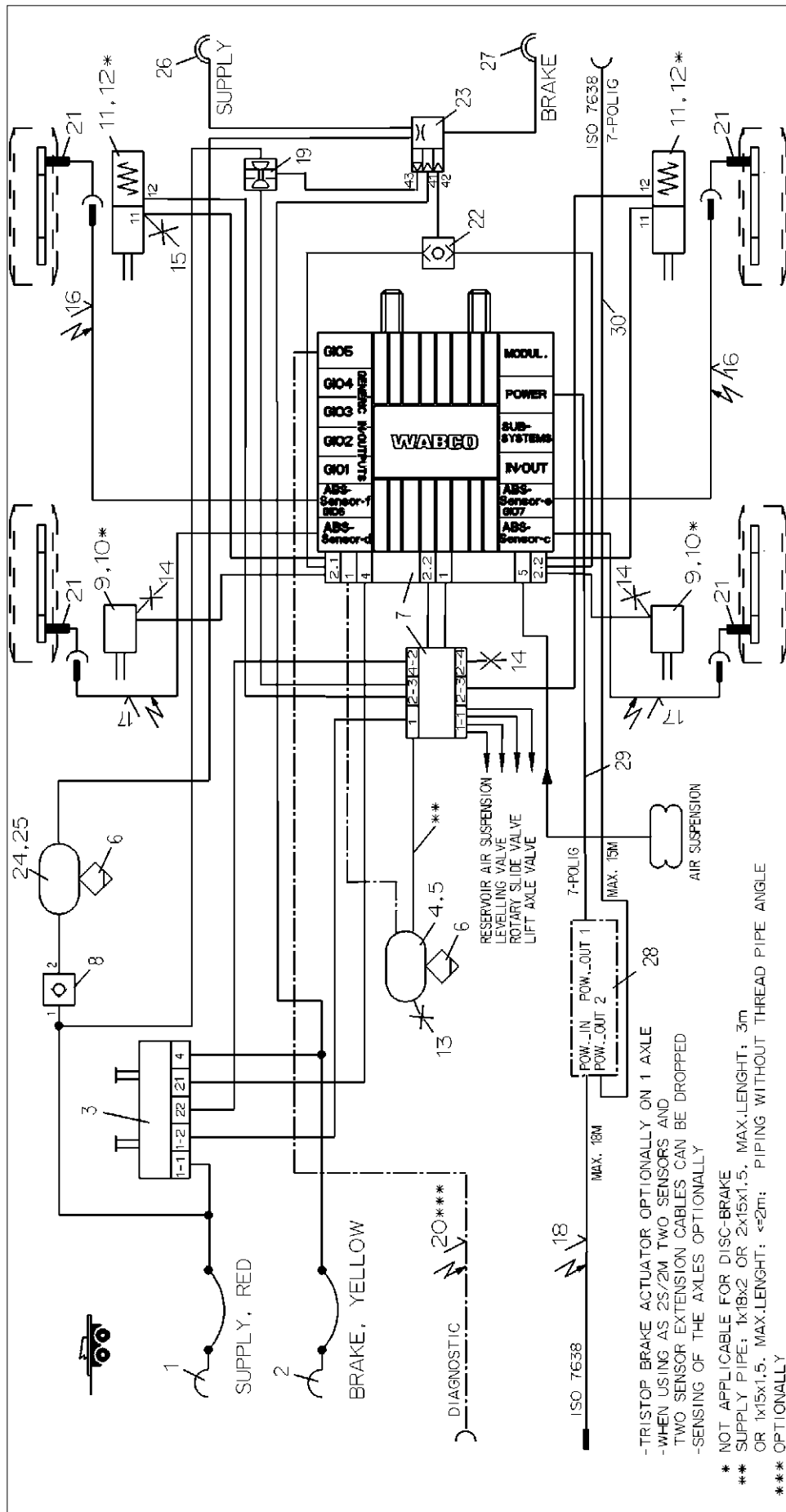

Pos.	Pos.	Denomination	Denomination	Product Identification No.	Pos.	Pos.	Denomination
15	1	TEST CONNECTION	463 703 036 0	30	1	SUPPLY (POWER) CABLE	449 135 ... 0
14	3	TEST CONNECTION	463 703 120 0	29	1	SUPPLY (POWER) CABLE	449 347 ... 0
13	1	TEST CONNECTION	463 703 115 0	28	1	CAN-ROUTER	446 122 050 07052 0
12	2	KIT	423 903 532 2	27	1	COUPLING HEAD AUTOM. BRAKE	952 200 222 0
11	2	TRISTOP BRAKE ACTUATOR	925 ... 0	26	1	COUPLING HEAD AUTOM. SUPPLY	952 200 221 0
10	2	KIT	423 000 ... 0	25	2	HOSE CLAMP	451 999 ... 2
9	2	BRAKE CHAMBER	423 10 ... 0	24	1	AIR RESERVOIR	950 ... 0
8	1	CHECK VALVE	434 014 000 0	23	1	TRAILER CONTROL VALVE	973 ... 0
7	1	TRAILER-MODULATOR W-EXTENSION MODUL	480 102 ... 0	22	2	SELECT HIGH VALVE	434 208 ... 0
6	2	DRAIN VALVE	934 300 001 0	21	4	ABS-SENSOR	441 032 8 ... 0
5	2	HOSE CLAMP	451 999 ... 2	20	1	DIAGNOSTIC CABLE	449 611 ... 0
4	1	AIR RESERVOIR	950 ... 0	19	1	DOUBLE CUT-OFF VALVE	434 500 003 0
3	1	PARK-RELEASE-EMERG.-VALVE (PREV)	971 002 9 ... 0	18	1	SUPPLY (POWER) CABLE	449 133 ... 0
2	1	COUPLING HEAD W. INT. LINE FILTER	952 201 ... 0	17	2	EXTENSION CABLE FOR SENSOR	449 723 ... 0
1	1	COUPLING HEAD W. INT. LINE FILTER	952 201 ... 0	16	2	EXTENSION CABLE FOR SENSOR	449 723 ... 0

WABCO
 TRAILER - EBS E
 WITH CAN-ROUTER
 4S/2M OR 2S/2M
 -DOLLY-

Copyright WABCO®
 Type: ...
 2009-04-15 BURMESTER
 2009-04-15 LANGOWICZ
 Part No.: BURMESTER
 Date of first issue: 2009-04-15
 02.2009 07.0000 Sheet

Part No.: 841 601 287 0
 Pro/E: A 3
 F.V.V.: 123576
 Techn. Reg.: A
 Scale: 1/1

- * NOT APPLICABLE FOR DISC-BRAKE
- ** SUPPLY PIPE: 1x18x2 OR 2x15x1.5. MAX.LENGTH: 3m
OR 1x15x1.5. MAX.LENGTH: <=2m: PIPING WITHOUT THREAD PIPE ANGLE
*** OPTIONALLY

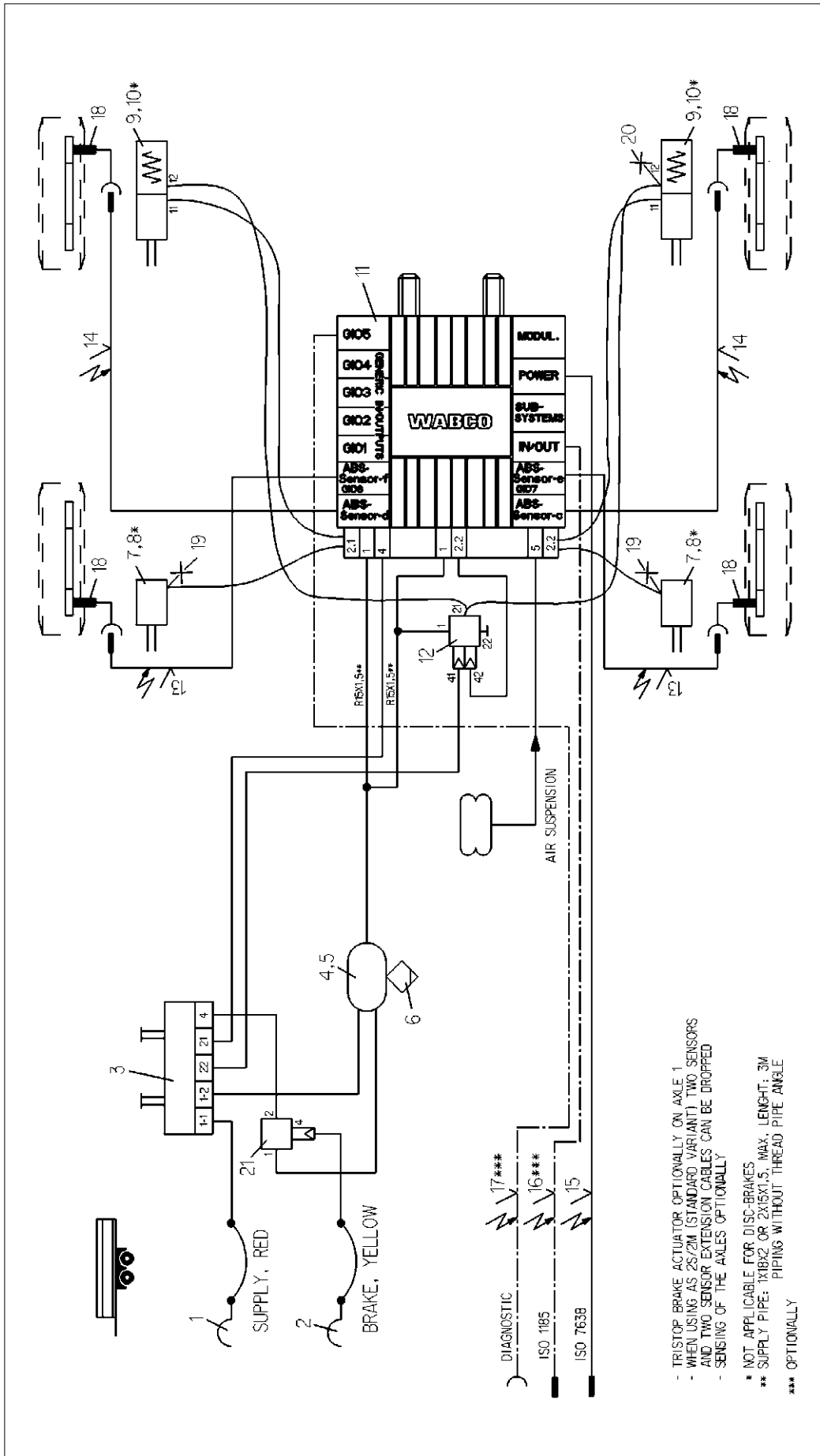

Example WABCO®		Part No.		Supply No.	
Part No.	Supply No.	Part No.	Supply No.	Part No.	Supply No.
973 011 201 0	24	973 011 0.. 0	21 1	RELAY VALVE	
480 102 ... 0	23	463 703 036 0	19 2	TEST CONNECTION	
423 903 532 2	22	463 703 120 0	18 4	ABS-SENSOR	
925 0	21	441 0	17 1	DIAGNOSTIC CABLE	
423 2	20	449 611 ... 0	16 1	24IN-CABLE	
423 0	19	449 349 ... 0	15 1	SUPPLY (POWER) CABLE	
934 300 001 0	18	449 273 ... 0	14 2	EXTENSION CABLE FOR SENSOR	
451 999 ... 2	17	449 723 ... 0	13 2	EXTENSION CABLE FOR SENSOR	
950 0	16	449 723 ... 0	13 2	EXTENSION CABLE FOR SENSOR	
971 002 9.. 0	15	449 723 ... 0	13 2	EXTENSION CABLE FOR SENSOR	
952 201 ... 0	14	449 723 ... 0	13 2	EXTENSION CABLE FOR SENSOR	
952 201 ... 0	13	449 723 ... 0	13 2	EXTENSION CABLE FOR SENSOR	

Product Identification No. Pos. Pos.

Denomination	Pos.	Pos.
OVERLOAD-PROTECTION-RV	24	
TRAILER-MODULATOR	23	
KIT	22	
TRISTOP BRAKE ACTUATOR	21	
KIT	20	
BRAKE CHAMBER	19	
DRAIN VALVE	18	
HOSE CLAMP	17	
AIR RESERVOIR	16	
PARK-RELEASE-EMERGENCY VALVE (PREV)	15	
COUPLING HEAD W.INT. LINE FILTER	14	
COUPLING HEAD W.INT. LINE FILTER	13	

Product Identification No. 973 011 201 0

Pos. 24

Pos. 23

Pos. 22

Pos. 21

Pos. 20

Pos. 19

Pos. 18

Pos. 17

Pos. 16

Pos. 15

Pos. 14

Pos. 13

WABCO
TRAILER - EBS E
FOR 2-AXLES-CENTRAL-AXLE TRAILER
2S/2M OR 4S/2M OPTIONALLY RSS

2011-08-29 BURMESTER
2011-08-29 CHRONIS
BURMESTER

841 601 289 0
EN 1/1

- TRISTOP BRAKE ACTUATOR OPTIONALLY ON AXLE 1
- WHEN USING AS 2S/2M (STANDARD VARIANT) TWO SENSORS AND TWO SENSOR EXTENSION CABLES CAN BE DROPPED
- SENSING OF THE AXLES OPTIONALLY
- * NOT APPLICABLE FOR DISC-BRAKES
- ** SUPPLY PIPE: 1X18X2 OR 2X15X1,5, MAX. LENGTH: 3M PIPING WITHOUT THREAD PIPE ANGLE
- *** OPTIONALLY

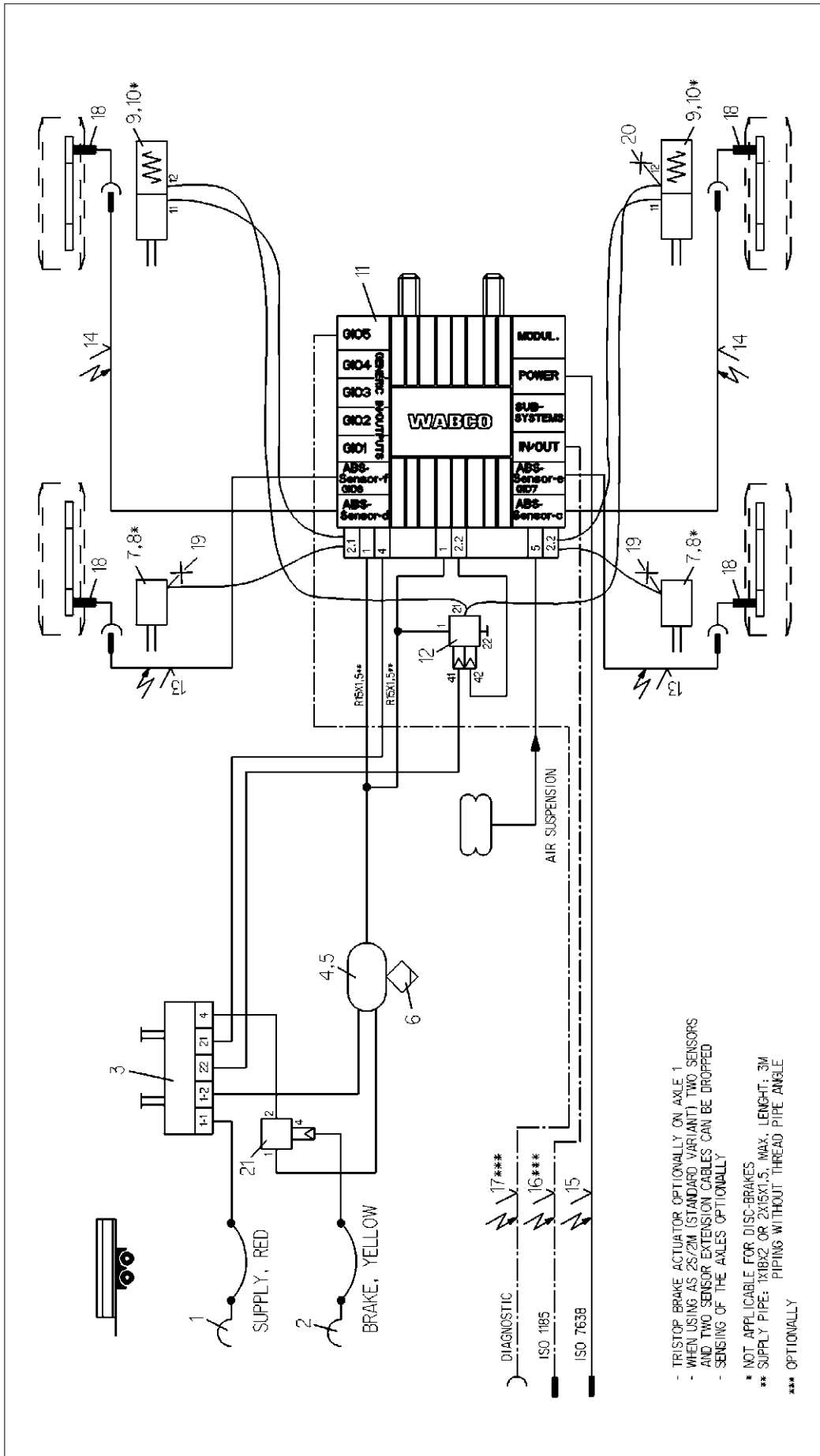

- TRISTOP BRAKE ACTUATOR OPTIONAL ON AXLE 1
 - WHEN USING AS 2S/2M (STANDARD VARIANT) TWO SENSORS AND TWO SENSOR EXTENSION CABLES CAN BE DROPPED
 - SENSING OF THE AXLES OPTIONAL
 * NOT APPLICABLE FOR DISC-BRAKES
 ** SUPPLY PIPE: 1X18X2 OR 2X15X1,5, MAX. LENGTH: 3M PIPING WITHOUT THREAD PIPE ANGLE
 *** OPTIONAL

Example WABCO®		Year	Subtype
12	1 OVERLOAD-PROTECTION-RV	973 011 201 0	24
11	1 TRAILER-MODULATOR	480 102 ... 0	23
10	2 KIT	423 903 532 2	22
9	2 TRISTOP BRAKE ACTUATOR	925 ... 0	21 1 RELAY VALVE
8	2 KIT	423 ... 2	20 1 TEST CONNECTION
7	2 BRAKE CHAMBER	934 300 001 0	18 4 ABS-SENSOR
6	1 DRAIN VALVE	451 999 ... 2	17 1 DIAGNOSTIC CABLE
5	2 HOSE CLAMP	950 ... 0	16 1 24IN-CABLE
4	1 AIR RESERVOIR	971 002 9... 0	15 1 SUPPLY (POWER) CABLE
3	1 PARK-RELEASE-EMERGENCY VALVE (PREV)	952 201 ... 0	14 2 EXTENSION CABLE FOR SENSOR
2	1 COUPLING HEAD W.INT. LINE FILTER		13 2 EXTENSION CABLE FOR SENSOR
1	1 COUPLING HEAD W.INT. LINE FILTER		
Fig. Pos.	Denomination	Product Identification No.	Pos. Pos.
			Denomination
WABCO			
TRAILER - EBS E			
FOR 2-AXLES-CENTRAL-AXLE TRAILER			
2S/2M OR 4S/2M OPTIONALLY RSS			
		Model No.	Date of the Issue: 2011-09-05
		841 601 289 0	Revision: 1.1 (page: 3/3)
		ECU No.	not n. RES.
		Reason	4990
		Pro/E	A 3
		Scale	
		Part	
		Model	BURMESTER
		Part No.	463 703 036 0
		Part No.	463 703 120 0
		Part No.	441 ... 0
		Part No.	449 611 ... 0
		Part No.	449 349 ... 0
		Part No.	449 273 ... 0
		Part No.	449 723 ... 0
		Part No.	449 723 ... 0

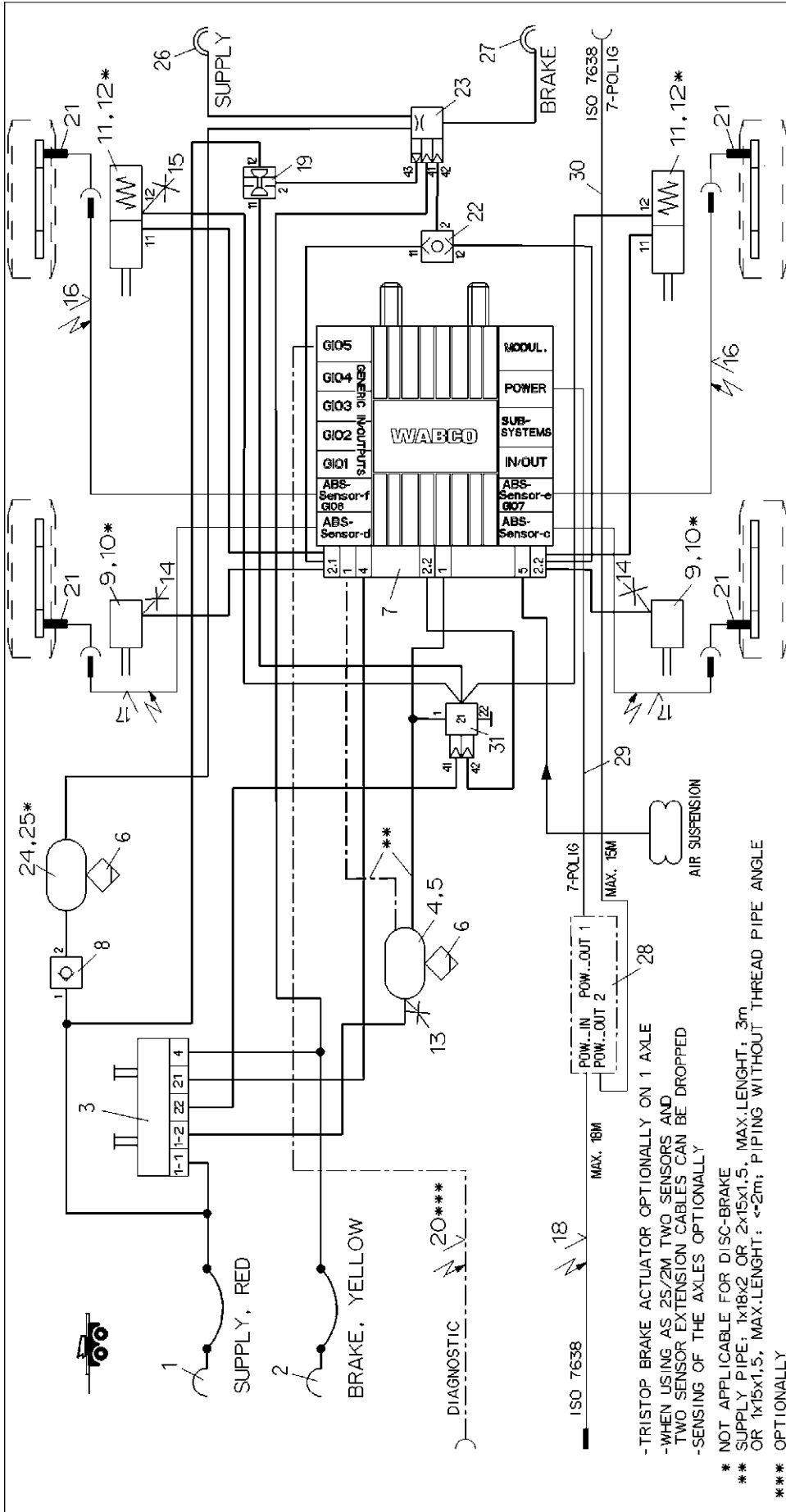

-TRISTOP BRAKE ACTUATOR OPTIONALLY ON 1 AXLE
 -WHEN USING AS 2S/2M TWO SENSORS AND TWO SENSOR EXTENSION CABLES CAN BE DROPPED
 -SENSING OF THE AXLES OPTIONALLY

* NOT APPLICABLE FOR DISC-BRAKE
 ** SUPPLY PIPE: 1x18x2 OR 2x15x1.5, MAX.LENIGHT: 3m OR 1x15x1.5, MAX.LENIGHT: $\leq 2\text{m}$; PIPING WITHOUT THREAD PIPE ANGLE
 *** OPTIONALLY

INDEX	DATE	DESCRIPTION OF CHANGE
A	2014-04-02	973 011 021 0 CHANGED INTO 973 011 201 0

WABCO	
TRAILER - EBS E	
WITH CAN-ROUTER	
4S/2M OR 2S/2M	
-DOLLY-	

2009-06-29	BURMESTER
2009-06-29	ORONIS
BURMESTER	

Part No.	973 011 201 0
Part No.	449 135 ... 0
Part No.	449 347 ... 0
Part No.	446 122 060 0/082 0
Part No.	952 200 222 0
Part No.	952 200 221 0
Part No.	451 999 ... 2
Part No.	950 ... 0
Part No.	973 ... 0
Part No.	434 206 ... 0
Part No.	441 032 8... 0
Part No.	449 611 ... 0
Part No.	434 500 003 0
Part No.	449 133 ... 0
Part No.	449 123 ... 0
Part No.	449 123 ... 0

Part No.	973 011 201 0	Product Identification No.
31 1	OVERLOAD-PROTECTION-RV	
30 1	SUPPLY CABLE	
29 1	SUPPLY CABLE	
28 1	CAN-ROUTER	
27 1	COUPLING HEAD AUTOM. BRAKE	
26 1	COUPLING HEAD AUTOM. SUPPLY	
25 2	HOSE CLAMP	
24 1	AIR RESERVOIR	
23 1	TRAILER CONTROL VALVE	
22 1	SELECT HIGH VALVE	
21 4	ABS-SENSOR	
20 1	DIAGNOSTIC CABLE	
19 1	DOUBLE CUT-OFF VALVE	
18 1	SUPPLY (POWER) CABLE	
17 2	EXTENSION CABLE FOR SENSOR	
16 2	EXTENSION CABLE FOR SENSOR	

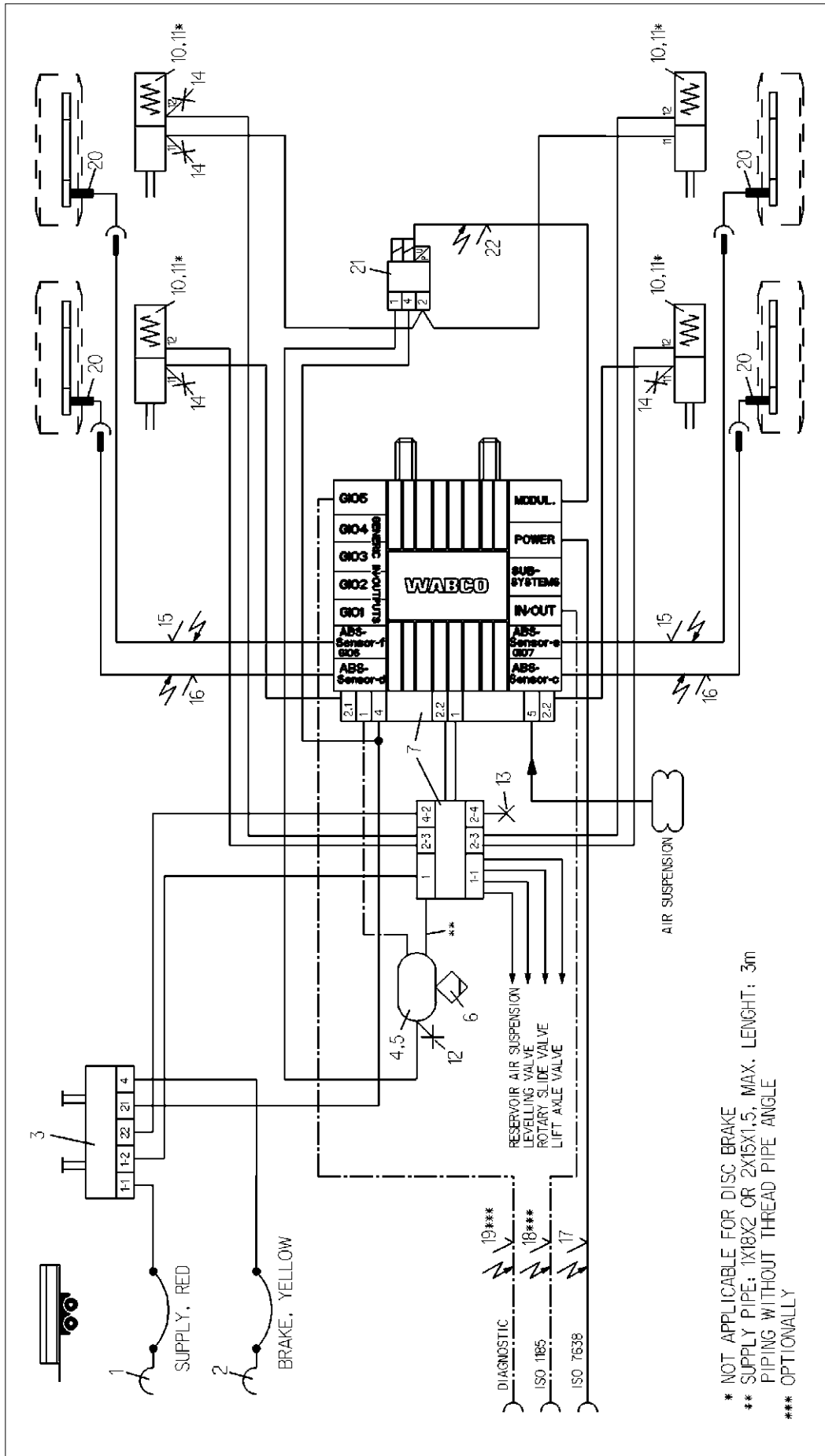

* NOT APPLICABLE FOR DISC BRAKE
 ** SUPPLY PIPE: 1X18X2 OR 2X15X1.5, MAX. LENGTH: 3m
 PIPING WITHOUT THREAD PIPE ANGLE
 *** OPTIONALLY

Part No.		Qty	Description	Pos.	Denomination	Product Identification No.	
12	1	1	TEST CONNECTION			463 703 ... 0	
11	4	1	KIT			* 423 903 532 2	
10	4	1	TRISTOP BRAKE ACTUATOR	22	1	CABLE TO EBS-RV	449 429 ... 0
9		1		21	1	EBS-RELAY VALVE	480 207 0... 0
8		4		20	4	ABS-SENSOR	441 032 B... 0
7	1	1	TRAILER-MODULATOR W.EXTENSION MODUL	19	1	DIAGNOSTIC CABLE	*** 449 611 ... 0
6	1	1	DRAIN VALVE	18	1	24N-CABLE	*** 449 349 ... 0
5	2	1	HOSE CLAMP	17	1	SUPPLY (POWER) CABLE	449 173 ... 0
4	1	1	AIR RESERVOIR	16	2	EXTENSION CABLE FOR SENSOR	449 723 ... 0
3	1	1	PARK-RELEASE-EMERG.-VALVE (PREV)	15	2	EXTENSION CABLE FOR SENSOR	449 723 ... 0
2	1	1	COUPLING HEAD W. INT.LINE FILTER	14	1	TEST CONNECTION	463 703 036 0
1	1	1	COUPLING HEAD W. INT.LINE FILTER	13	3	TEST CONNECTION	463 703 120 0

WABCO		TRAILER - EBS E	
		FOR 2-AXLES-CENTRAL-AXLE TRAILER	
		4S/3M - PEM-	
Part No.		841 601 322 0	
Rev. No.		002	
EN		1/1	
E.C. No.		-	
Rev. No.		4990	

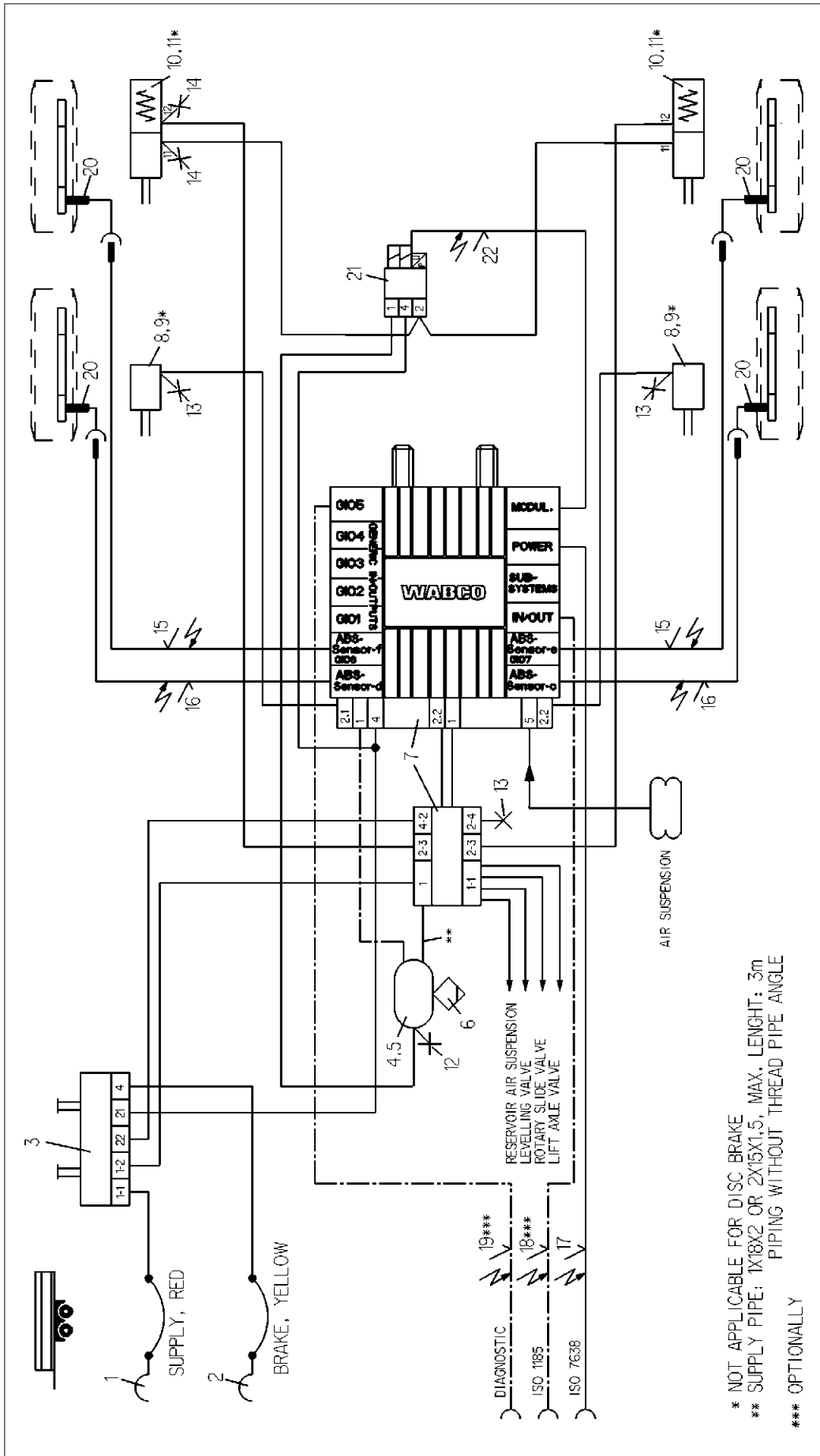

Copyright WABCO®		Title		Symbol	
Item	Drawn	Item	Drawn	Item	Drawn
2010-06-07	BURMESTER	2010-06-07	BURMESTER	TRAILER - EBS E	
2010-06-07	CHRONIS	2010-06-07	CHRONIS	FOR 2-AXLES-CENTRAL-AXLE TRAILER	
BURMESTER		BURMESTER		4S/3M - PEM-	
National Vn.		National Vn.		Date of this document: 06-07	
Scale		Scale		Ex. Code	
43		43		002	
Part No.		Part No.		EN	
A 3		A 3		1/1	
Product Identification No.		Product Identification No.		Part. Dep.	
463 703 120 0		463 703 120 0		4990	

* NOT APPLICABLE FOR DISC BRAKE
 ** SUPPLY PIPE: 1X18X2 OR 2X15X1,5, MAX. LENGTH: 3m
 PIPING WITHOUT THREAD PIPE ANGLE
 *** OPTIONALLY

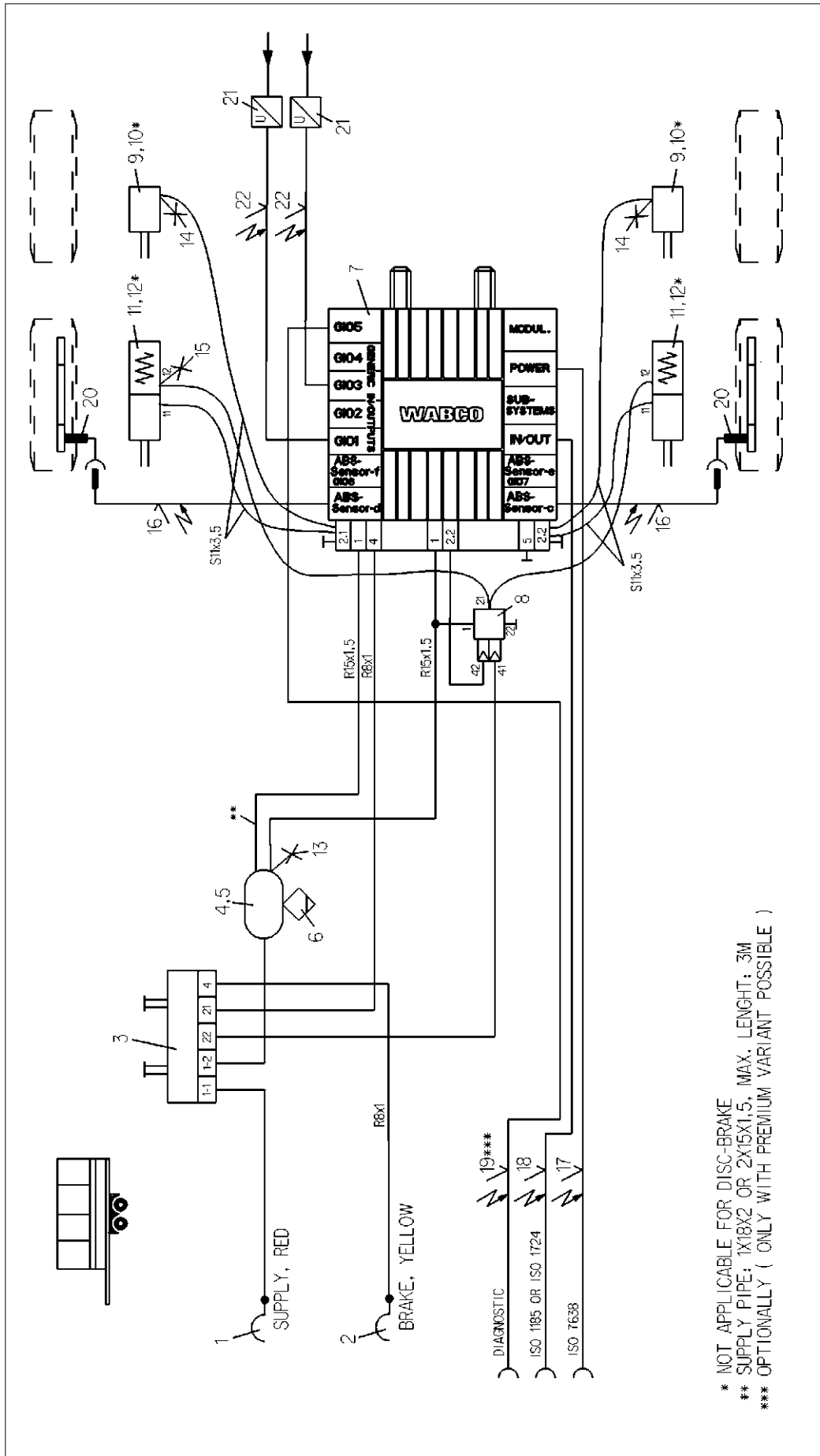

* NOT APPLICABLE FOR DISC-BRAKE
 ** SUPPLY PIPE: 1X18X2 OR 2X15X1.5, MAX. LENGTH: 3M
 *** OPTIONALLY (ONLY WITH PREMIUM VARIANT POSSIBLE)

WABCO		Date of issue: 01-09-17	
TRAILER - EBS E		Scale: 1/1	
FOR 2-AXLES-CENTRE AXLE-TRAILERS		Revision: 002	
AGRICULT. TRAILER W. HYDR. SUSPENSION		EN 171	
PREV. ABS-2S/2M AND OVERLOAD PROTECTION RV		Material: HWR 00456	
(MULTIVOLTAGE)		Part No. Res.: 4990	
841 601 324 0		ECU No.: 4990	
A 3 Pro/E		4990	

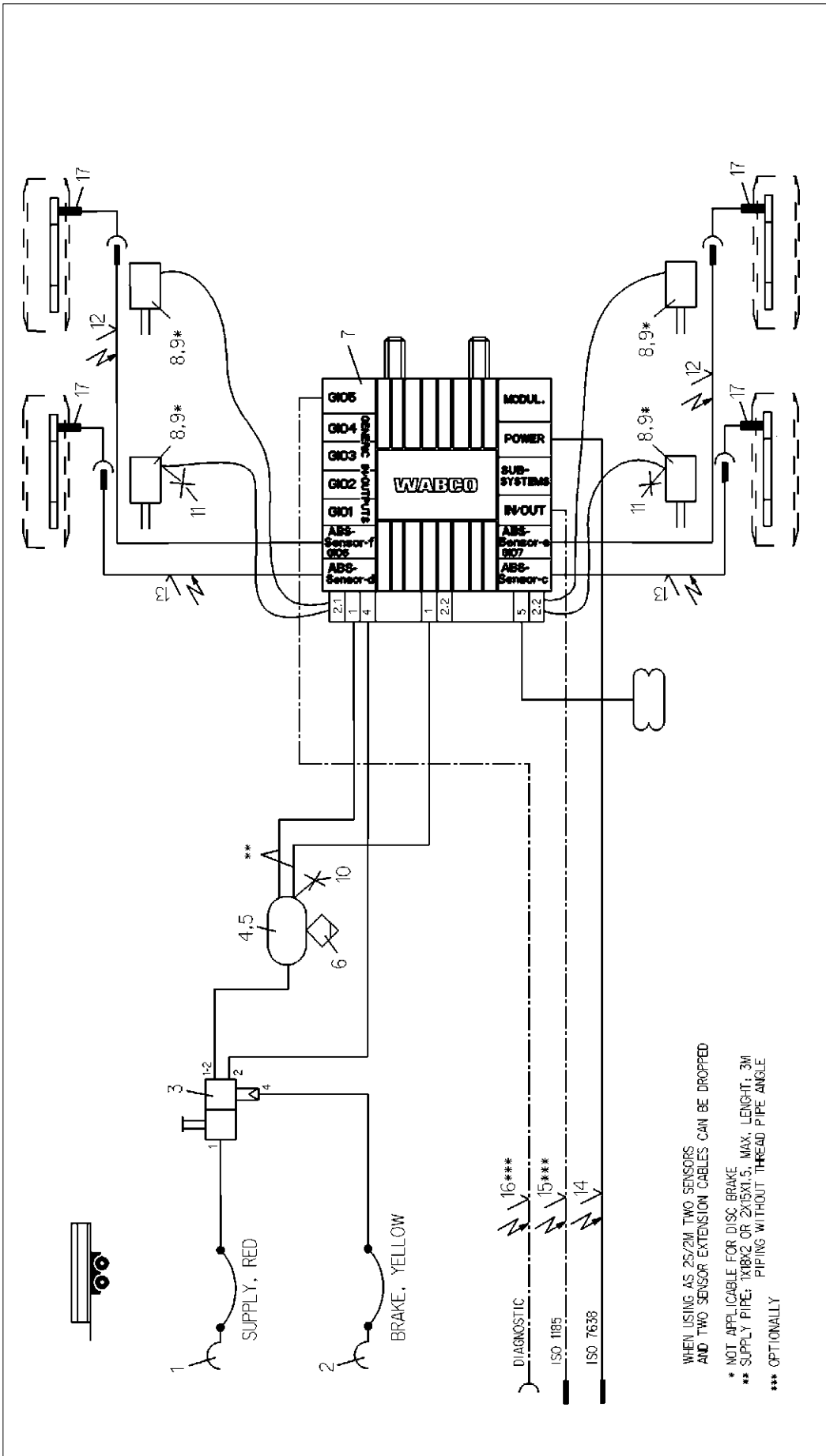

WHEN USING AS 2S/2M TWO SENSORS AND TWO SENSOR EXTENSION CABLES CAN BE DROPPED

* NOT APPLICABLE FOR DISC BRAKE
 ** SUPPLY PIPE: 1X18X2 OR 2X15X1,5, MAX. LENGTH: 3M PIPING WITHOUT THREAD PIPE ANGLE
 *** OPTIONALLY

Fig./Pos.	Denomination	Product Identification No.	Pos./Pos.	Denomination	2axle/1-2 axle/2-3 axle		Date of first issue/001-1-25
					Cable	Sample	
12	EXTENSION CABLE FOR SENSOR	449 723 ... 0					
11	TEST CONNECTION	463 703 120 0					
10	TEST CONNECTION	463 703 115 0					
9	KIT	423 2					
8	BRAKE CHAMBER	423 0					
7	TRAILER-MODULATOR	934 300 001 0					
5	HOSE CLAMP	451 999 ... 2	17	4	ABS-SENSOR	441 032 B... 0	
4	AIR RESERVOIR	950 0	16	1	DIAGNOSTIC CABLE	449 611 ... 0	
3	TRAILER BRAKE VALVE	971 002 700 0	15	1	24W-CABLE	449 349 ... 0	
2	COUPLING HEAD W. INT.LINE FILTER	952 201 ... 0	14	1	SUPPLY (POWER) CABLE	449 273 ... 0	
1	COUPLING HEAD W. INT.LINE FILTER	952 201 ... 0	13	2	EXTENSION CABLE FOR SENSOR	449 723 ... 0	
	Denomination	Product Identification No.	Pos./Pos.	Denomination	WABCO		
					TRAILER - EBS E		
					FOR 2-AXLES-CENTRAL AXLE TRAILER		
					4S/2M OR 2S/2M		
					WABCO		
					841 601 325 0		
					ECU No.	Revision	Expiry Date
					-	-	4990
					EN	EN	1/1
					002	002	002

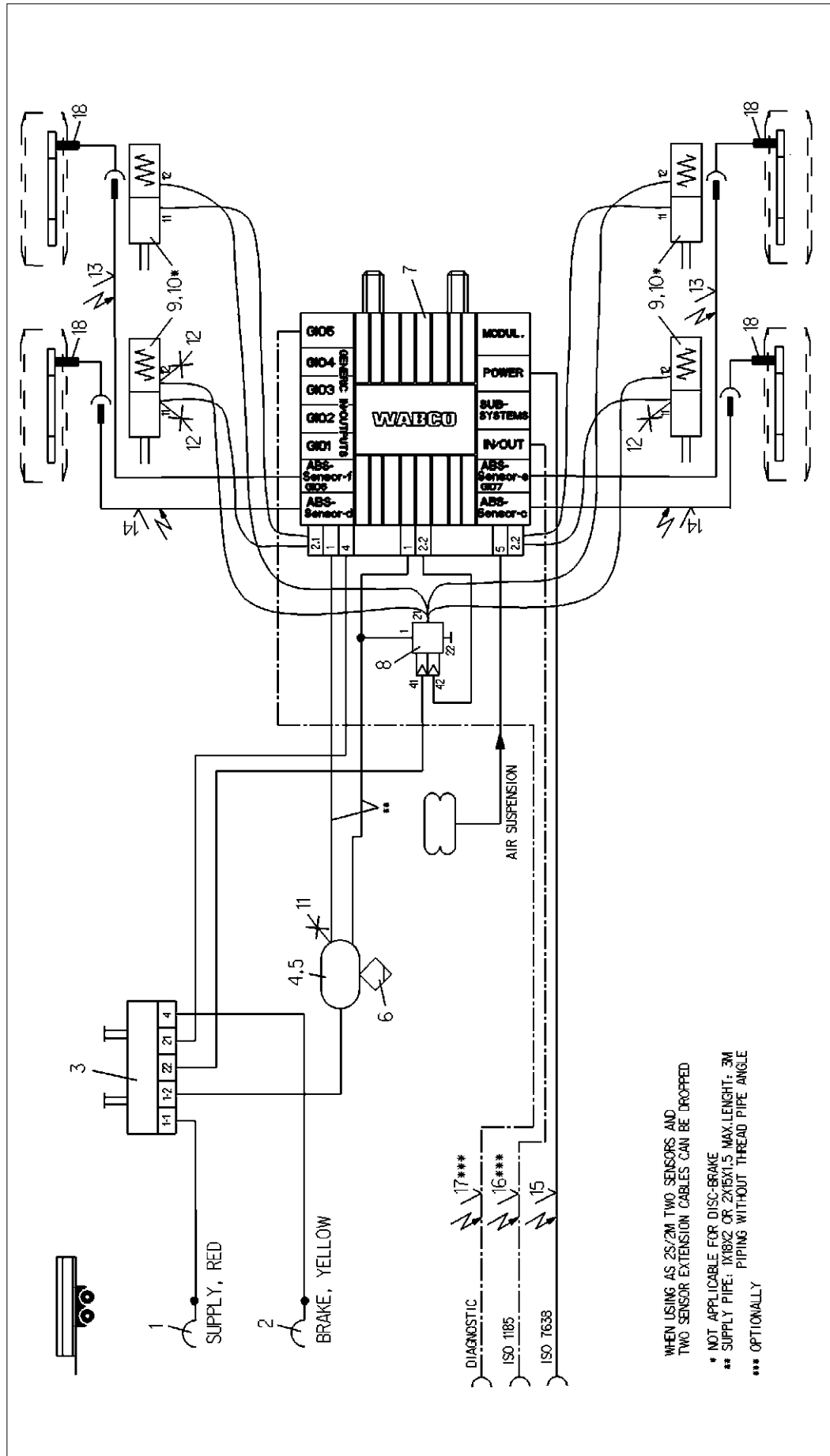

WHEN USING AS 2S/2M TWO SENSORS AND TWO SENSOR EXTENSION CABLES CAN BE DROPPED
 * NOT APPLICABLE FOR DISC-BRAKE
 ** SUPPLY PIPE: 1X18X2 OR 2X18X1.5 MAX.LENGTH: 3M PIPING WITHOUT THREAD PIPE ANGLE
 *** OPTIONALLY

12	3	TEST CONNECTION	463 703 036 0	24					
11	1	TEST CONNECTION	463 703 115 0	23					
10	4	KIT	423 903 532 2	22					
9	4	TRISTOP BRAKE ACTUATOR	925 0	21					
8	1	OVERLOAD-PROTECTION-RV	973 011 201 0	20					
7	1	TRAILER-MODULATOR	480 702 ... 0	19					
6	1	DRAIN VALVE	534 300 001 0	18	4	ABS-SENSOR	441 032 8... 0		
5	2	HOSE CLAMP	451 999 ... 2	17	1	DIAGNOSTIC CABLE	449 611 ... 0		
4	1	AIR RESERVOIR	950 0	16	1	2-IN-CABLE	449 349 ... 0		
3	1	PARK-RELEASE-EMERGENCY VALVE (PREV)	971 002 9... 0	15	1	SUPPLY (POWER) CABLE	449 173 ... 0		
2	1	COUPLING HEAD W.INT. LINE FILTER	952 201 ... 0	14	2	EXTENSION CABLE FOR SENSOR	449 723 ... 0		
1	1	COUPLING HEAD W.INT. LINE FILTER	952 201 ... 0	13	2	EXTENSION CABLE FOR SENSOR	449 723 ... 0		
Pos./Pos.		Denomination	Product Identification No.	Pos./Pos.		Denomination	Product Identification No.		

WABCO
 TRAILER - EBS E
 FOR 2-AXLES-CENTRALAXLE TRAILER
 4S/2M OR 2S/2M

Copyright WABCO®
 Date: 2013-10-28
 Drawn: BURMESTER
 Checked: SCHMIDT
 Expert: BURMESTER
 Scale: 1:1

Multipl. No.: 841 601 326 0
 Date of first issue: 2013-10-28
 Doc.Code: EN
 Language: EN
 Sheet: 1/1

Rev. No.: A 3
 Tech. Resp.: 4990

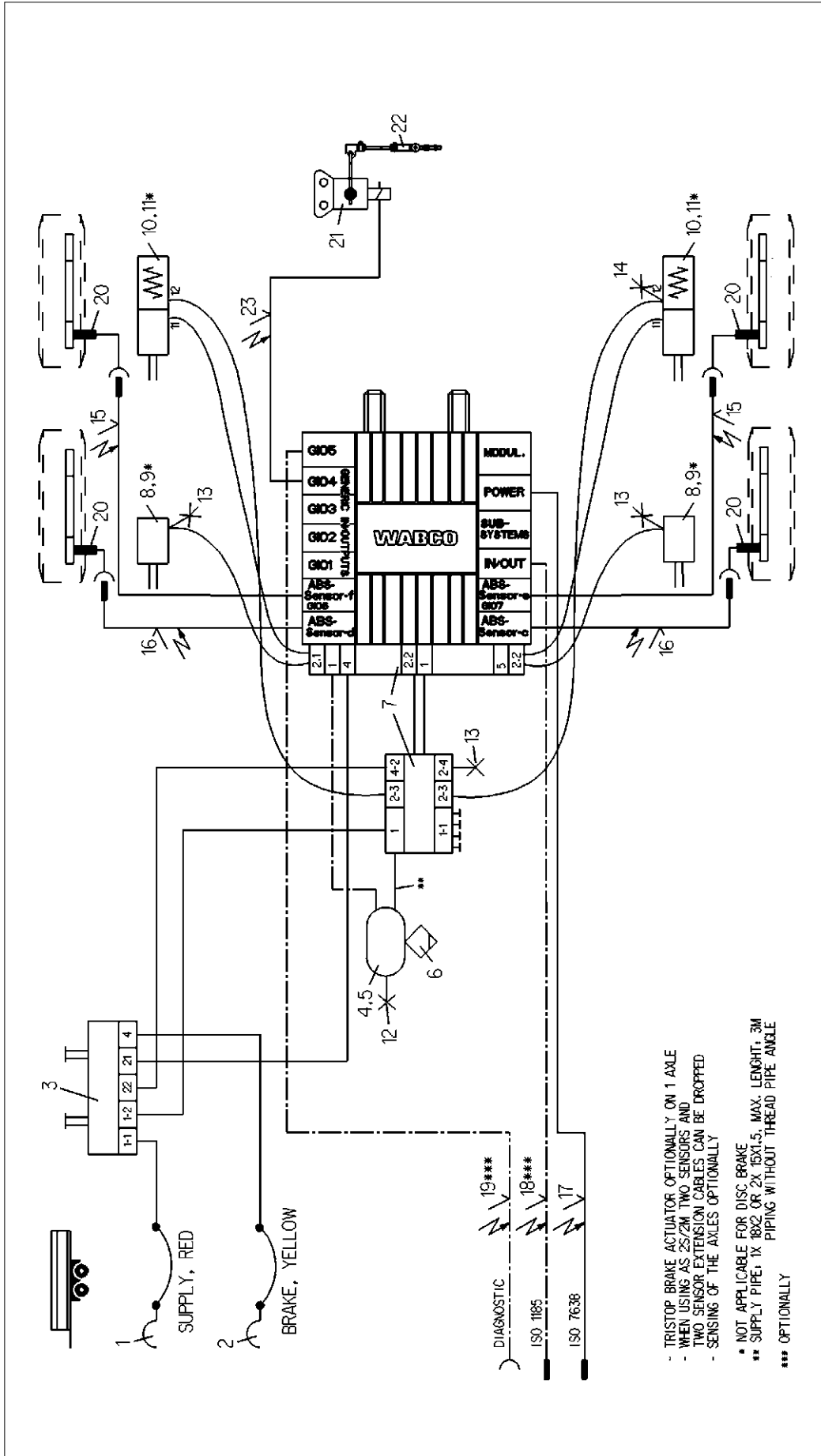

Copyright WABCO®		Date	Signature
WABCO		2014-02-10	BURMESTER
TRAILER - EBS E		Checked	
FOR 2-AXLES-CENTRAL-AXLE TRAILER		Expert	
4S/2M OR 2S/2M -PEM-		Miss	
Material No.		Date of first issue: 2014-02-10	
841 601 327 0		Doc.Code	Language
Ech.No.		Revision	Replacement for
A 3		Pro/E	4990

Pos. No.	Denomination	Product Identification No.	Pos. Pts.	Denomination	Product Identification No.
12 1	TEST CONNECTION	463 703 115 0			
11 2	KIT	423 903 532 2	23 1	GIO-CABLE DISTANCE SENSOR	449 811 ... 0
10 2	TRISTOP BRAKE ACTUATOR	925 0	22 1	LINKAGE	453 401 003 0
9 2	KIT	423 000 ... 2	21 1	DISTANCE SENSOR	441 050 100 0
8 2	BRAKE CHAMBER	423 10 ... 0	20 4	ABS-SENSOR	441 032 8 ... 0
7 1	TRAILER MODULATOR W.EXTENSION MIDDLE	480 102 ... 0	19 1	24W-CABLE	449 611 ... 0
6 1	DRAIN VALVE	934 300 001 0	18 1	SUPPLY (POWER) CABLE	449 349 ... 0
5 2	HOSE CLAMP	451 999 ... 2	17 1	EXTENSION CABLE FOR SENSOR	449 273 ... 0
4 1	AIR RESERVOIR	950 0	16 2	TEST CONNECTION	449 723 ... 0
3 1	PARK-RELEASE-EMERGENCY VALVE (PREV)	971 002 9... 0	15 2	EXTENSION CABLE FOR SENSOR	449 723 ... 0
2 1	COUPLING HEAD W.INT.-LINE FILTER	952 201 ... 0	14 1	TEST CONNECTION	463 703 036 0
1 1	COUPLING HEAD W.INT.-LINE FILTER	952 201 ... 0	13 3	TEST CONNECTION	463 703 120 0

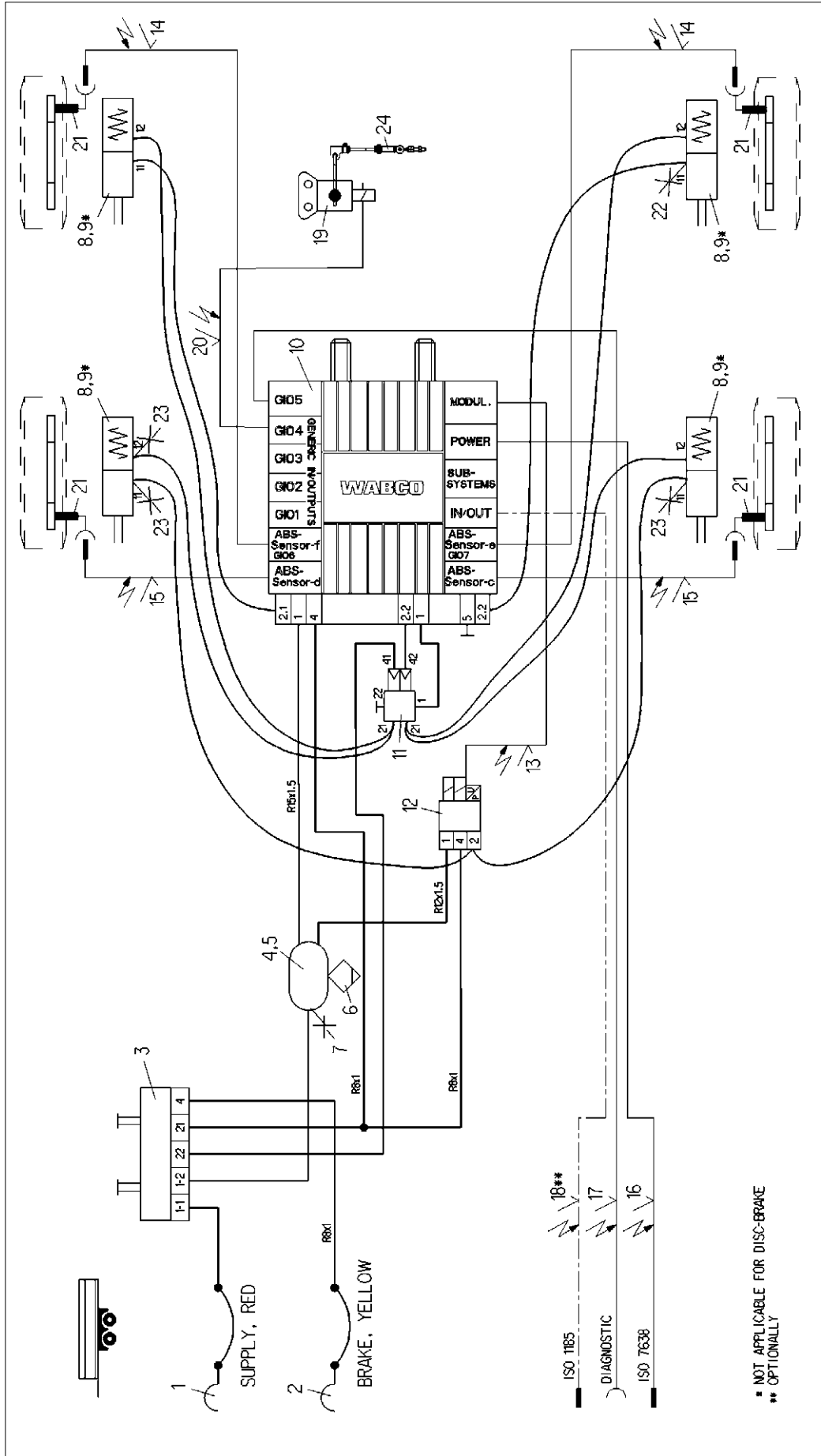

* NOT APPLICABLE FOR DISC-BRAKE
 ** OPTIONALLY

Fig. Pos.	Denomination	Product Identification No.	Pos. Pos.	Denomination	Product Identification No.		
12	1	EBS-RELAY VALVE	480 207 0... 0	24	1	LINKAGE	433 401 0033 0
11	1	OVERLOAD-PROTECTION-RV	973 011 201 0	23	3	TEST CONNECTION	463 703 036 0
10	1	TRAILER-MODULATOR	480 102 ... 0	22	1	TEST CONNECTION	463 703 120 0
9	4	KIT	423 903 532 2	21	4	ABS-SENSOR	441 0
8	4	TRISTOP BRAKE ACTUATOR	925 0	20	1	GIO-CABLE-DISTANCE SENSOR	449 811 ... 0
7	1	TEST CONNECTION	463 703 ... 0	19	1	DISTANCE SENSOR	441 050 100 0
6	1	DRAIN VALVE	934 300 001 0	18	1	24N-CABLE	449 349 ... 0
5	2	HOSE CLAMP	451 999 ... 2	17	1	DIAGNOSTIC CABLE	449 611 ... 0
4	1	AIR RESERVOIR	950 0	16	1	SUPPLY (POWER) CABLE	449 273 ... 0
3	1	PARK-RELEASE-EMERGENCY VALVE (PREV)	971 002 9... 0	15	2	EXTENSION CABLE FOR SENSOR	449 723 ... 0
2	1	COUPLING HEAD W/INT.LINE FILTER	952 201 ... 0	14	2	EXTENSION CABLE FOR SENSOR	449 723 ... 0
1	1	COUPLING HEAD W/INT.LINE FILTER	952 201 ... 0	13	1	CABLE TO EBS-RV	449 429 ... 0

WABCO		Date of first issue: 2015-03-30
Date	Signature	Sheet
2015-03-30	BURMESTER	002
2015-03-30	SCHMIDT	EN
Project	Part No.	1/1
BURMESTER	841 601 328 0	
Model	Revision	
4S/3M WITH RSS, VB-AGGREGATE	4990	
MECH. SUSPENSION		

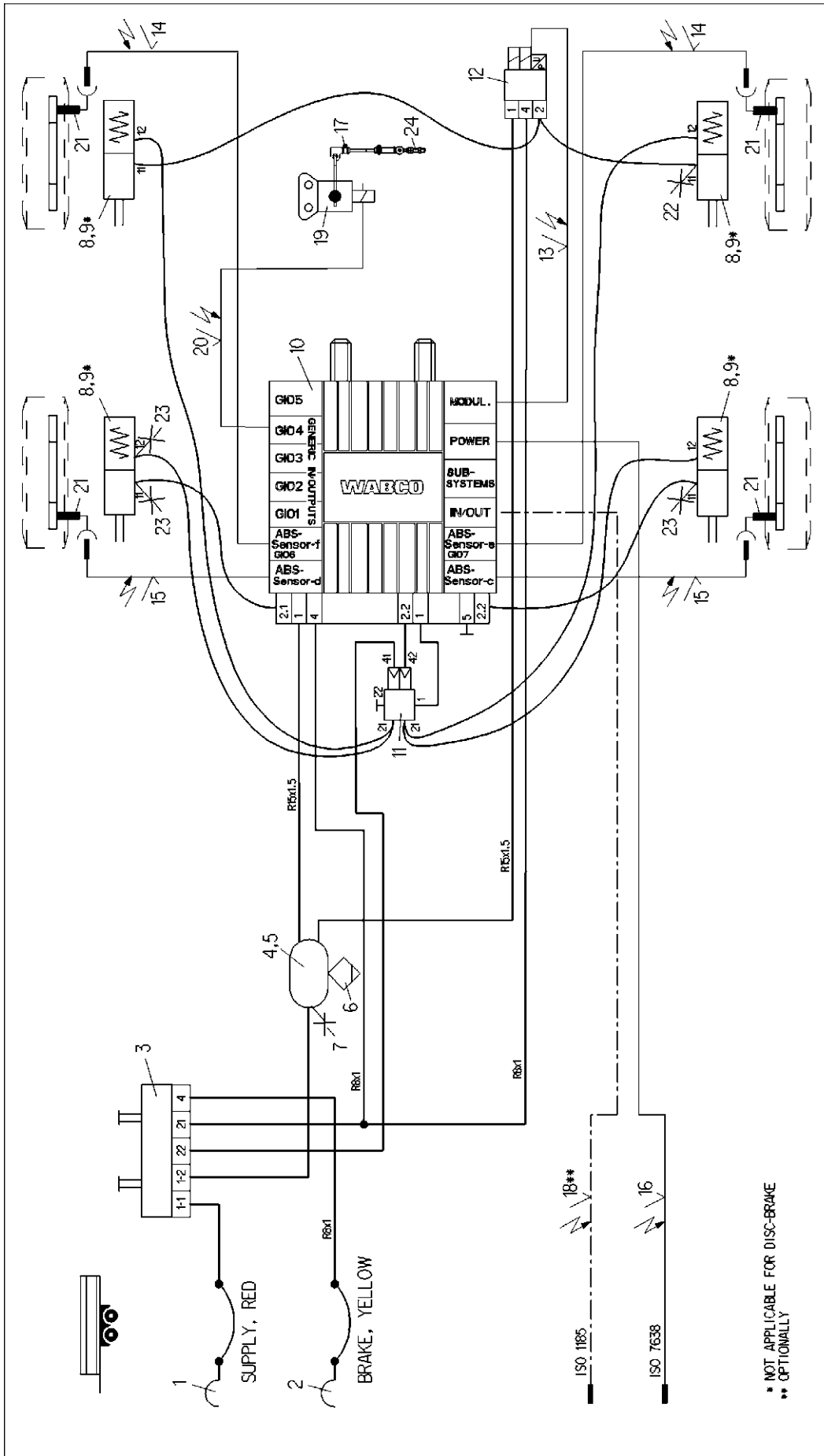

* NOT APPLICABLE FOR DISC-BRAKE
 ** OPTIONALLY

Copyright WABCO®		WABCO	
Year	2015-03-31	Version	2015-03-31
System	BURMESTER	System	BURMESTER
TRAILER - EBS E			
FOR 2-AXLES-CENTRAL-AXLE TRAILER			
4S/3M WITH RSS, W-AGGREGATE			
MECH. SUSPENSION			
Date of first issue: 2015-03-31		Date of last issue: 2015-03-31	
Doc. Code	841 601 329 0	Doc. Code	841 601 329 0
Part No.	002	Part No.	002
Revision	EN	Revision	EN
Product Identification No.	A 3	Product Identification No.	A 3
Denomination	Denomination	Denomination	Denomination
Page	1/1	Page	1/1

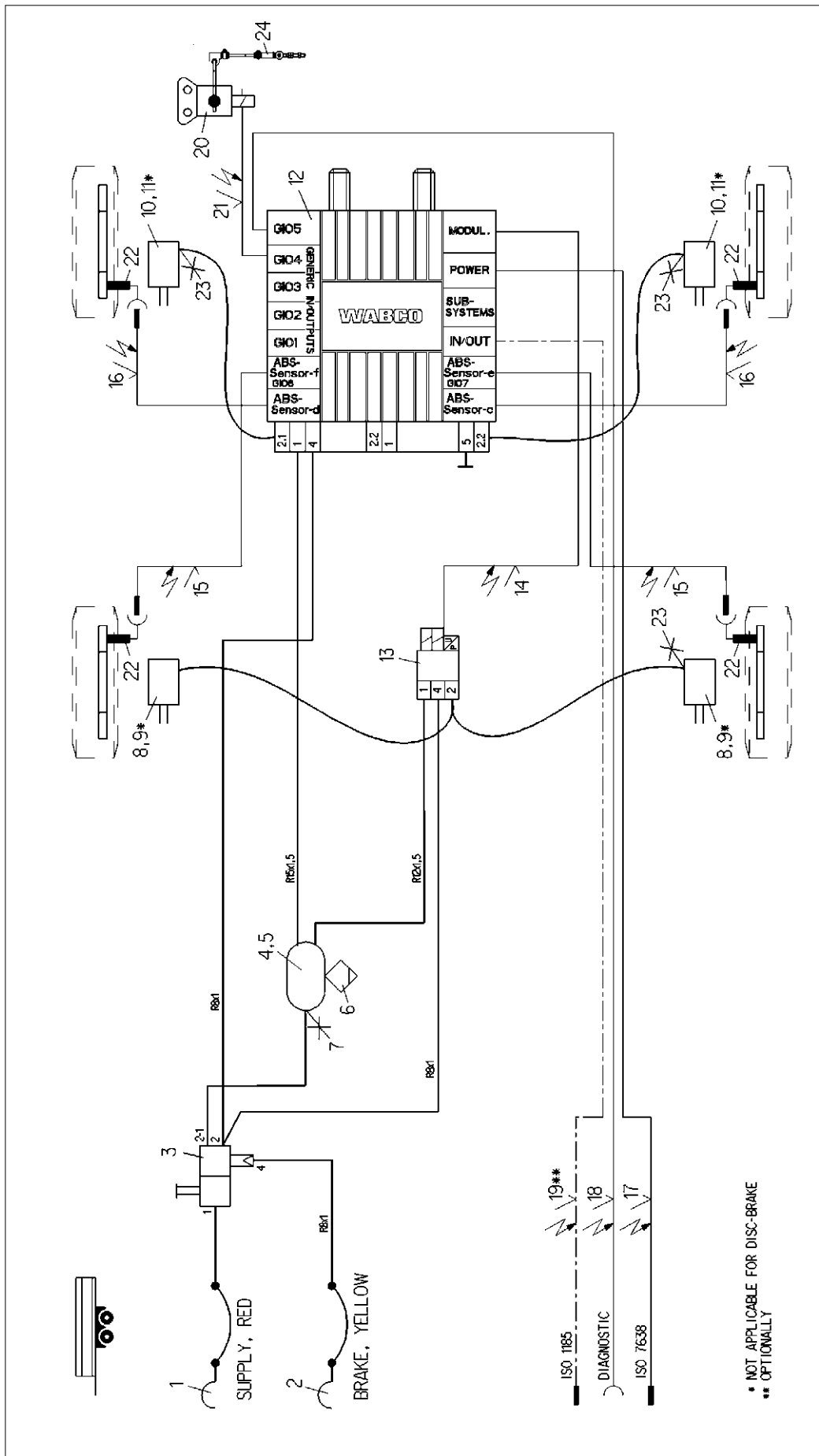

* NOT APPLICABLE FOR DISC-BRAKE
** OPTIONALLY

Part No.		Denomination		Product Identification No.		Pos. Pos.		Denomination		Product Identification No.	
12	1	TRAILER-MODULATOR	480 102 ... 0	24	1	LINKAGE	433 401 003 0				
11	2	KIT	423 ... 2	23	3	TEST CONNECTION	463 703 120 0				
10	2	BRAKE CHAMBER	423 ... 0	22	4	ABS-SENSOR	441 ... 0				
9	2	KIT	423 ... 2	21	1	GIO-CABLE-DISTANCE SENSOR	449 811 ... 0				
8	2	BRAKE CHAMBER	423 ... 0	20	1	DISTANCE SENSOR	441 050 100 0				
7	1	TEST CONNECTION	463 703 ... 0	19	1	24V-CABLE	449 349 ... 0				
6	1	DRAIN VALVE	934 300 001 0	18	1	DIAGNOSTIC CABLE	449 611 ... 0				
5	2	HOSE CLAMP	451 999 ... 2	17	1	SUPPLY (POWER) CABLE	449 273 ... 0				
4	1	AIR RESERVOIR	950 ... 0	16	2	EXTENSION CABLE FOR SENSOR	449 723 ... 0				
3	1	TRAILER-BRAKE VALVE	971 002 703 0	15	2	EXTENSION CABLE FOR SENSOR	449 723 ... 0				
2	1	COUPLING HEAD W. INT.LINE FILTER	952 201 ... 0	14	1	CABLE TO EBS-RV	449 429 ... 0				
1	1	COUPLING HEAD W. INT.LINE FILTER	952 201 ... 0	13	1	EBS-RELAY VALVE	480 207 0... 0				
Date of first issue: 2015-06-03											
Part No.: 841 601 392 0											
Revision: EN 1/1											
Requirements for:											
A 3 OREO											
EQUIP. Techn. Resp. 4990											

WABCO
TRAILER - EBS E
FOR 2-AXLES-CENTRAL-AXLE TRAILER
4S/3M WITH PSS, V8-BOGIE
MECH. SUSPENSION

Part of 1608300

Copyright WABCO®
Date: 2015-06-03
From: BURMESTER
Part of: ORONIS
Part of: BURMESTER
Date: 2015-06-03

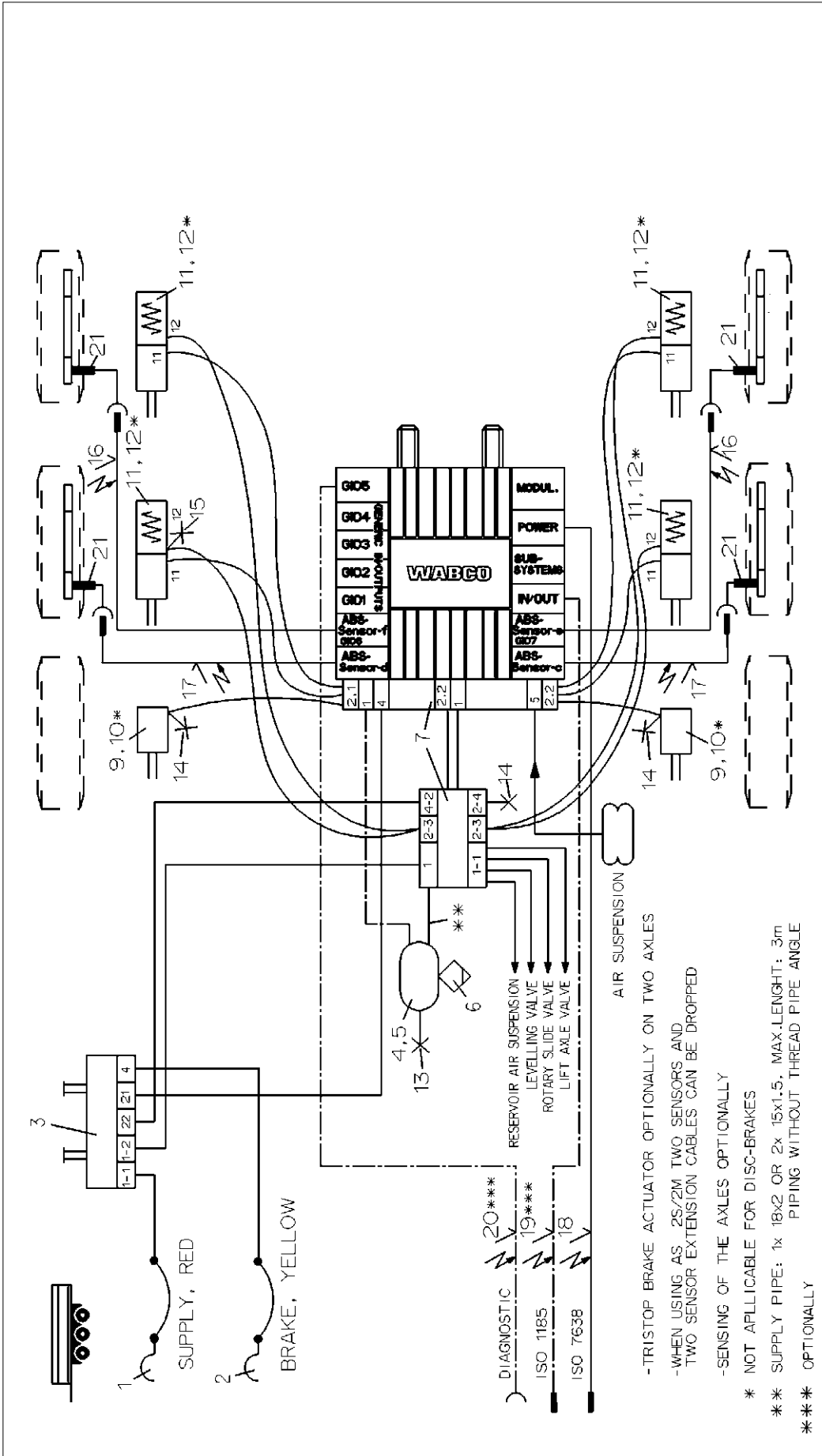

Pos.	Pcs.	Denomination	Pos. Pcs.	Denomination
12	4	KIT	423 903 532 2	
11	4	TRISTOP BRAKE ACTUATOR	925 0	
10	2	KIT	423 000 ... 2	
9	2	BRAKE CHAMBER	423 10 ... 0	21 4 ABS-SENSOR
8				20 1 DIAGNOSTIC CABLE
7	1	TRAILER-MODULATOR W. EXTENSION MODUL	480 102 ... 0	19 1 24N-CABLE
6	1	DRAIN VALVE	934 300 001 0	18 1 SUPPLY (POWER) CABLE
5	2	HOSE CLAMP	451 999 ... 2	17 2 EXTENSION CABLE FOR SENSOR
4	1	AIR RESERVOIR	950 0	16 2 EXTENSION CABLE FOR SENSOR
3	1	PARK-RELEASE-EMERGENCY VALVE (PREV)	971 002 9... 0	15 1 TEST CONNECTION
2	1	COUPLING HEAD W. INT. LINE FILTER	952 201 ... 0	14 3 TEST CONNECTION
1	1	COUPLING HEAD W. INT. LINE FILTER	952 201 ... 0	13 1 TEST CONNECTION

Copyright © WABCO
 Date: 2008-09-30
 Edition: BURMESTER
 Replaced: 2008-09-30
 Edition: CHRONIS
 Part No.: BURMESTER
 Model No.:
 Date of first issue: 2008-09-30
 Code: 841 601 300 0
 Page: 1/1
 Replaces: EN 171
 Product identification No.: 4990

- * TRISTOP BRAKE ACTUATOR OPTIONALY ON TWO AXLES
- ** WHEN USING AS 2S/2M TWO SENSORS AND TWO SENSOR EXTENSION CABLES CAN BE DROPPED
- *** SENSING OF THE AXLES OPTIONALY
- * NOT APPLICABLE FOR DISC-BRAKES
- ** SUPPLY PIPE: 1x 18x2 OR 2x 15x1.5, MAX. LENGTH: 3m PIPING WITHOUT THREAD PIPE ANGLE
- *** OPTIONALY

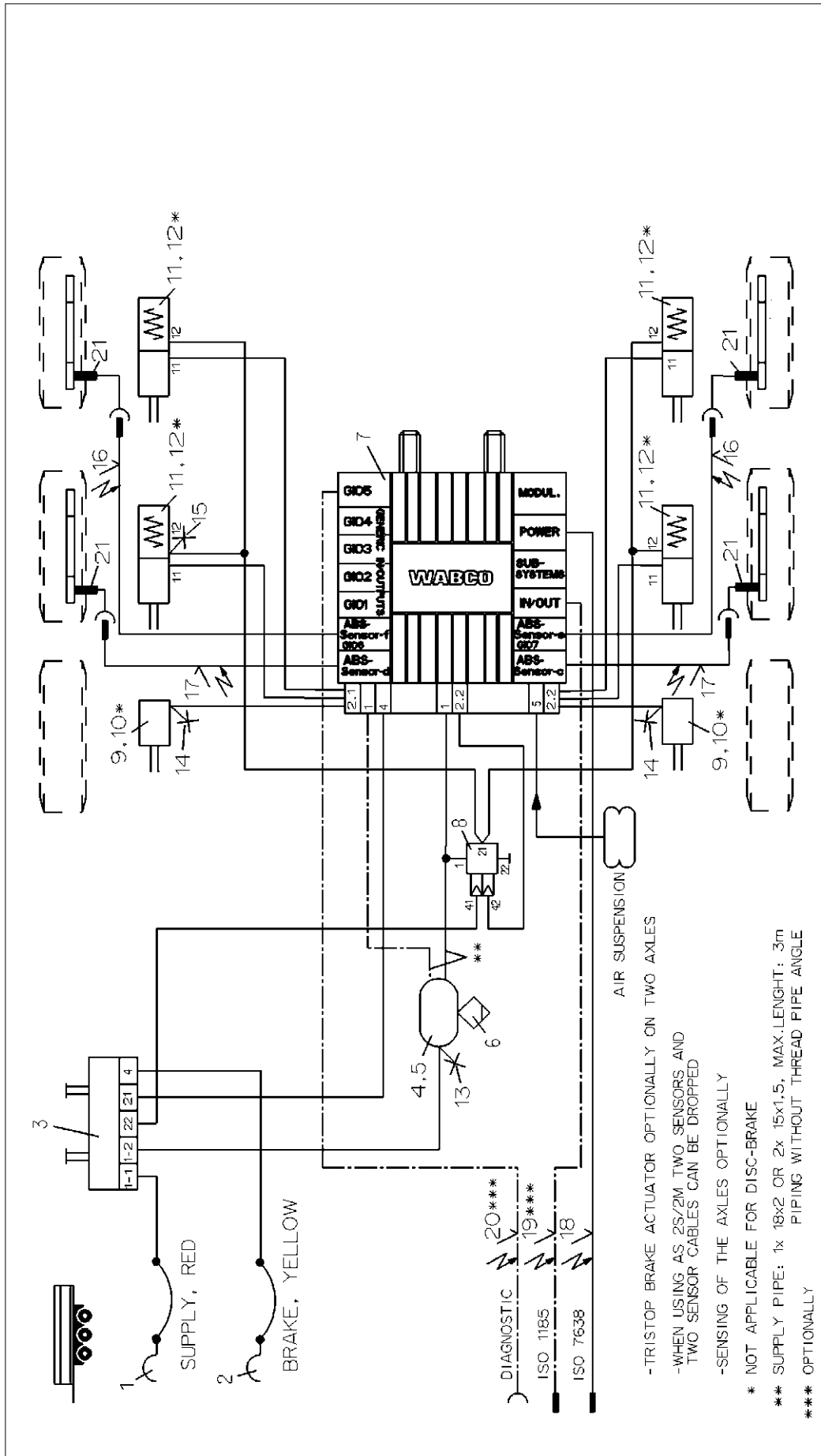

-TRISTOP BRAKE ACTUATOR OPTIONALLY ON TWO AXLES
 -WHEN USING AS 2S/2M TWO SENSORS AND TWO SENSOR CABLES CAN BE DROPPED
 -SENSING OF THE AXLES OPTIONALLY
 * NOT APPLICABLE FOR DISC-BRAKE
 ** SUPPLY PIPE: 1x 18x2 OR 2x 15x1,5, MAX. LENGTH: 3m PIPING WITHOUT THREAD PIPE ANGLE
 *** OPTIONALLY

Pos. Pos.	Denomination	Product Identification No.	Pos. Pos.	Denomination	Product Identification No.
12 4	TRISTOP BRAKE ACTUATOR	423 903 532 2			
11 4	TRISTOP BRAKE ACTUATOR	925 ... 0			
10 2	KIT	423 000 ... 2			
9 2	BRAKE CHAMBER	423 10 ... 0	21 4	ABS-SENSOR	441 032 8.. 0
8 1	OVERLOAD PROTECTION RV	973 011 201 0	20 1	DIAGNOSTIC CABLE	449 611 ... 0
7 1	TRAILER-MODULATOR W. EXTENSION MODUL	480 102 ... 0	19 1	24IN-CABLE	449 349 ... 0
6 1	DRAIN VALVE	934 300 001 0	18 1	POWER CABLE	449 273 ... 0
5 2	HOSE CLAMP	451 999 ... 2	17 2	EXTENSION CABLE FOR SENSOR	449 723 ... 0
4 1	AIR RESERVOIR	950 ... 0	16 2	EXTENSION CABLE FOR SENSOR	449 723 ... 0
3 1	PARK-RELEASE-EMERG.-VALVE (PREV)	971 002 9.. 0	15 1	TEST CONNECTION	463 703 036 0
2 1	COUPLING HEAD W. INT. LINE FILTER	952 201 ... 0	14 2	TEST CONNECTION	463 703 120 0
1 1	COUPLING HEAD W. INT. LINE FILTER	952 201 ... 0	13 1	TEST CONNECTION	463 703 ... 0

2x2-pin wabco®		3-pin	
Jobs	Year	Checked	Scale
	2009-10-21	BURMESTER	
TRAILER - EBS E			
FOR 3-AXLES-CENTRAL-AXLES TRAILER			
4S/2M OR 2S/2M			
Material No.		841 601 301 0	
Part No.	Subst.	Techn. Res.	Replacement Part
			002 EN 1/1
EA's No.	Wabco's		4990

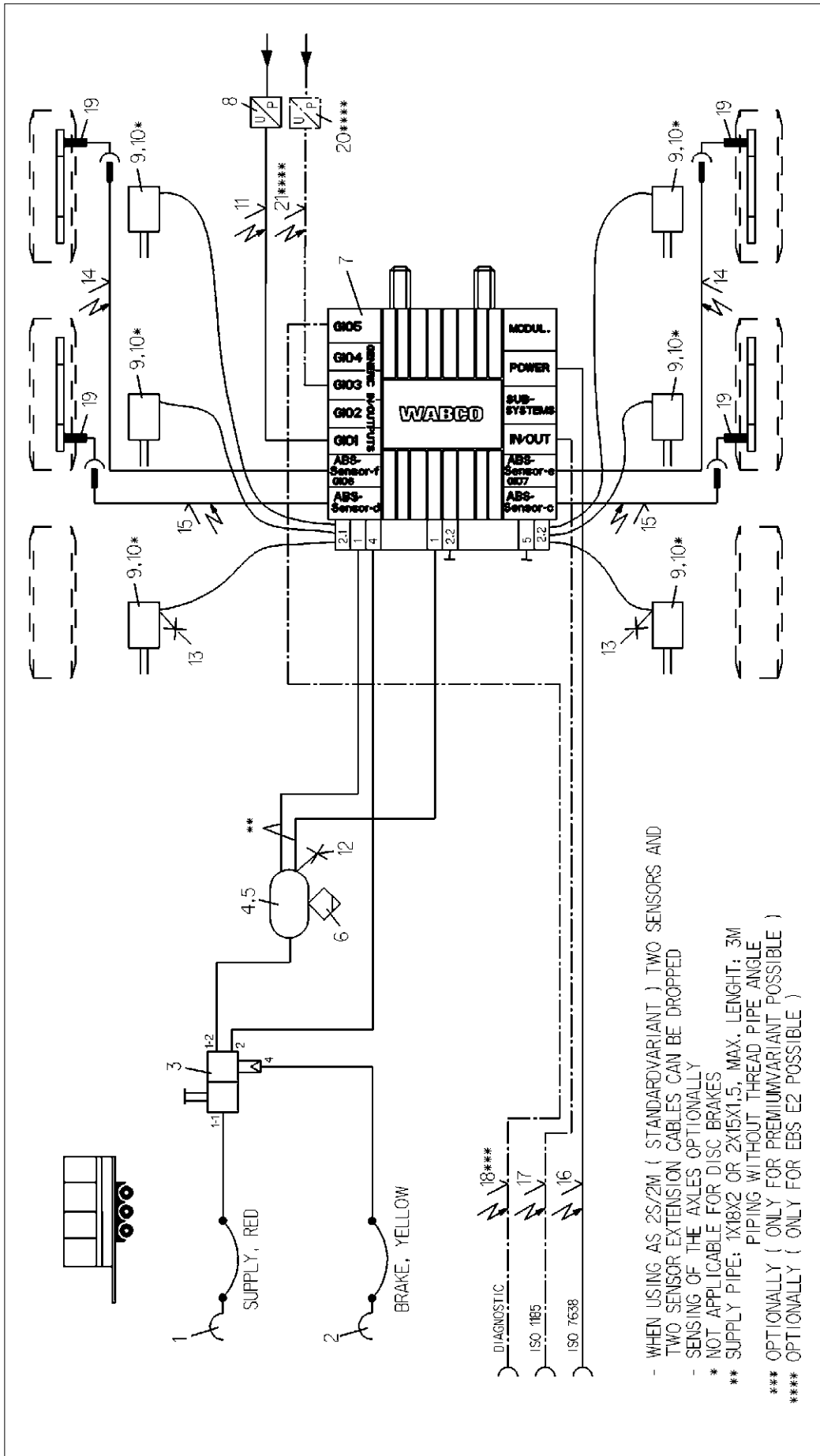

- WHEN USING AS 2S/2M (STANDARDVARIANT) TWO SENSORS AND TWO SENSOR EXTENSION CABLES CAN BE DROPPED
- SENSING OF THE AXLES OPTIONALLY
- * NOT APPLICABLE FOR DISC BRAKES
- ** SUPPLY PIPE: 1X18X2 OR 2X15X1,5, MAX. LENGTH: 3M PIPING WITHOUT THREAD PIPE ANGLE
- *** OPTIONALLY (ONLY FOR PREMIUMVARIANT POSSIBLE)
- **** OPTIONALLY (ONLY FOR EBS E2 POSSIBLE)

Pos. Pos.	Denomination	Product Identification No.	Pos. Pos.	Denomination	Product Identification No.
12 1	TEST CONNECTION	463 703 115 0			
11 1	CABLE PRESSURE SENSOR	449 812 ... 0			
10 6	KIT	423 000 ... 2			
9 6	BRAKE CHAMBER	423 10 ... 0	21 1	CABLE PRESSURE SENSOR	449 812 ... 0
8 1	PRESS. SENSOR HYDRAULIC OIL	NOT WABCO	20 1	PRESS. SENSOR HYDRAULIC OIL	441 032 8... 0
7 1	TRAILER-MODULATOR	934 300 001 0	19 4	ABS-SENSOR	449 611 ... 0
6 1	DRAIN VALVE	451 999 ... 2	18 1	DIAGNOSTIC CABLE	449 173 ... 0
5 2	HOSE CLAMP	950 ... 0	17 1	24N-CABLE	449 349 ... 0
4 1	AIR RESERVOIR	971 002 703 0	16 1	SUPPLY (POWER) CABLE	449 723 ... 0
3 1	TRAILER-BRAKE VALVE W. RELEASE VALVE	952 201 ... 0	15 2	EXTENSION CABLE FOR SENSOR	449 723 ... 0
2 1	COUPLING HEAD W. INT. LINE FILTER	952 201 ... 0	14 2	EXTENSION CABLE FOR SENSOR	463 703 120 0
1 1	COUPLING HEAD W. INT. LINE FILTER		13 2	TEST CONNECTION	

WABCO
 TRAILER - EBS E
 FOR 3-AXLE-CENTRE AXLE TRAILERS
 4S/2M OR 2S/2M
 (MULTIVOLTAGE MODULATOR)
 Material No. 841 601 302 0
 Date of the issue: 2010-09-27

Core	2010-09-27	BURMESTER
Subtype	2010-09-27	CHRONIS
Core	2010-09-27	BURMESTER
Subtype	2010-09-27	CHRONIS

Core	2010-09-27	BURMESTER
Subtype	2010-09-27	CHRONIS
Core	2010-09-27	BURMESTER
Subtype	2010-09-27	CHRONIS

Core	2010-09-27	BURMESTER
Subtype	2010-09-27	CHRONIS
Core	2010-09-27	BURMESTER
Subtype	2010-09-27	CHRONIS

Core	2010-09-27	BURMESTER
Subtype	2010-09-27	CHRONIS
Core	2010-09-27	BURMESTER
Subtype	2010-09-27	CHRONIS

Core	2010-09-27	BURMESTER
Subtype	2010-09-27	CHRONIS
Core	2010-09-27	BURMESTER
Subtype	2010-09-27	CHRONIS

Core	2010-09-27	BURMESTER
Subtype	2010-09-27	CHRONIS
Core	2010-09-27	BURMESTER
Subtype	2010-09-27	CHRONIS

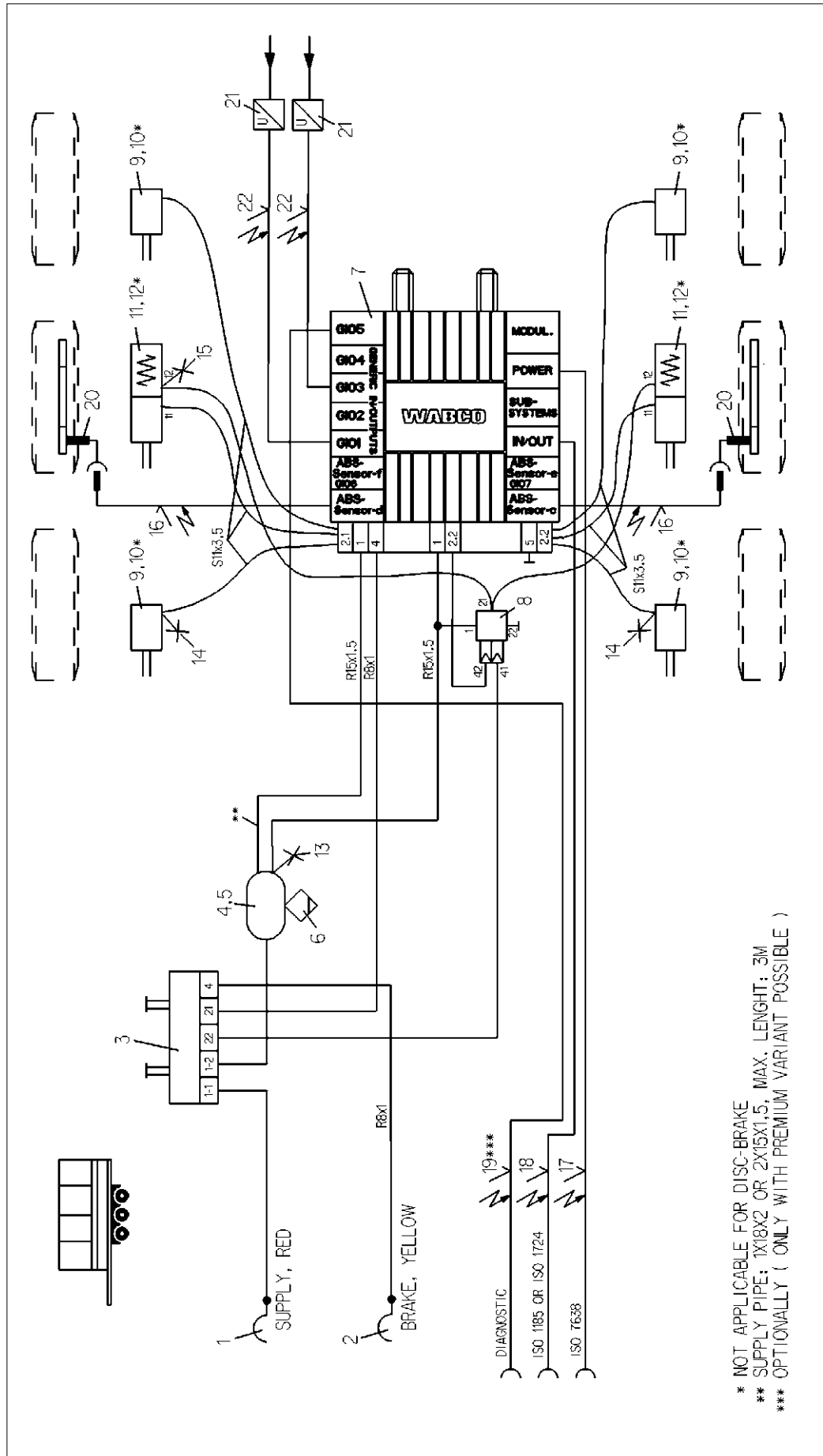

* NOT APPLICABLE FOR DISC-BRAKE
 ** SUPPLY PIPE: 1X18X2 OR 2X15X1.5, MAX. LENGTH: 3M
 *** OPTIONALLY (ONLY WITH PREMIUM VARIANT POSSIBLE)

2-pin/3-pin wabco®		3-pin/4-pin		5-pin/6-pin	
Jobs	1-pin	2-pin	3-pin	4-pin	5-pin
11	2	423 903 532 2			
12	2	925 ... 0			
10	4	423 000 ... 2	22 2	CABLE PRESSURE SENSOR	449 812 ... 0
9	4	423 10 ... 0	21 2	PRESS. SENSOR HYDRAULIC OIL	
8	1	973 011 201 0	20 2	ABS-SENSOR	441 032 8.. 0
7	1	480 102 ... 0	19 1	DIAGNOSTIC CABLE	449 611 000 0
6	1	934 300 001 0	18 1	24N-CABLE	449 349 000 0
5	2	451 999 ... 2	17 1	SUPPLY (POWER) CABLE	449 1... 0
4	1	950 ... 0	16 2	EXTENSION CABLE	449 723 000 0
3	1	971 002 9.. 0	15 1	TEST CONNECTION	463 703 036 0
2	1	952 201 ... 0	14 2	TEST CONNECTION	463 703 120 0
1	1	952 201 ... 0	13 1	TEST CONNECTION	463 703 ... 0
Pos. Pos.	Denomination	Product Identification No.	Pos. Pos.	Denomination	Product Identification No.
			A 3	Pro/E	
				ECV No.	
				Material No.	
				Part No.	
				Scale	
				Fig.	
				JAE System	
				Technical Res.	
				4990	
				Replacement In	
				EN	1/1
				002	
				841 601 303 0	

WABCO

TRAILER - EBS E
 FOR 3-AXLES-CENTRE AXLE-TRAILERS
 AGRICULT. TRAILER W. HYDR. SUSPENSION
 PREV. ABS-2S/2M AND OVERLOAD PROTECTION RV
 (MULTIVOLTAGE)

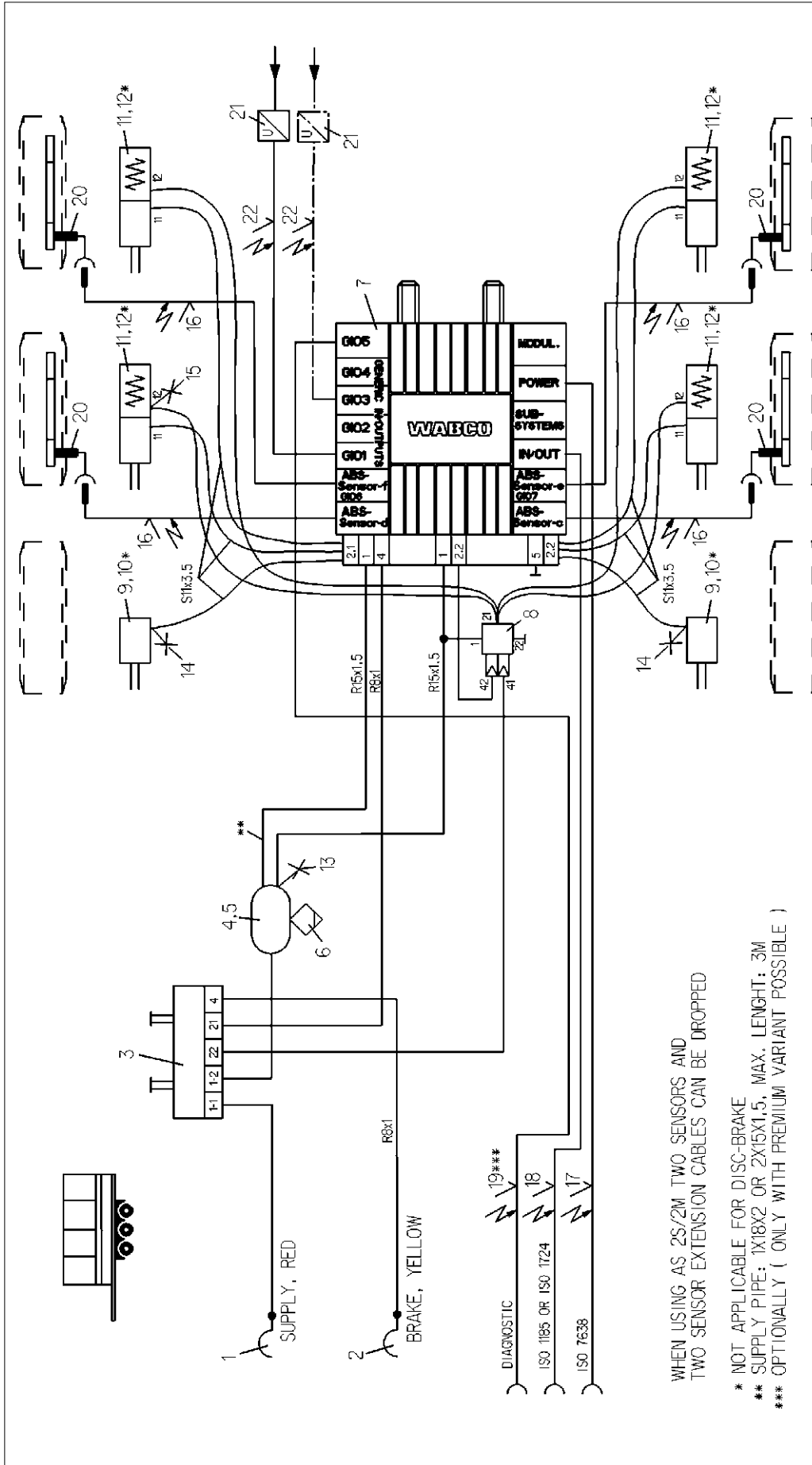

WHEN USING AS 2S/2M TWO SENSORS AND TWO SENSOR EXTENSION CABLES CAN BE DROPPED

* NOT APPLICABLE FOR DISC-BRAKE

** SUPPLY PIPE: 1X18X2 OR 2X15X1,5, MAX. LENGTH: 3M

*** OPTIONALLY (ONLY WITH PREMIUM VARIANT POSSIBLE)

Pos. Pos.	Denomination	Product Identification No.	Pos. Pos.	Denomination	Product Identification No.
12 4	KIT	423 903 532 2			
11 4	TRISTOP BRAKE ACTUATOR	925 0			
10 2	KIT	423 000 ... 2	22 2	CABLE PRESSURE SENSOR	449 812 ... 0
9 2	BRAKE CHAMBER	423 10 ... 0	21 2	PRESS. SENSOR-HYDRAULIC OIL	441 032 8.. 0
8 1	OVERLOAD-PROTECTION RV	973 011 201 0	20 4	ABS-SENSOR	449 611 000 0
7 1	TRAILER-MODULATOR	480 102 ... 0	19 1	DIAGNOSTIC CABLE	449 349 000 0
6 1	DRAIN VALVE	934 300 001 0	18 1	24N-CABLE	449 1.. .. 0
5 2	HOSE CLAMP	451 999 ... 2	17 1	SUPPLY (POWER) CABLE	449 723 000 0
4 1	AIR RESERVOIR	950 0	16 4	EXTENSION CABLE	463 703 036 0
3 1	PARK-RELEASE-EMERG.VALVE (PREV)	971 002 9.. 0	15 1	TEST CONNECTION	463 703 120 0
2 1	COUPLING HEAD W.INT. LINE FILTER	952 201 ... 0	14 2	TEST CONNECTION	463 703 ... 0
1 1	COUPLING HEAD W.INT. LINE FILTER	952 201 ... 0	13 1	TEST CONNECTION	463 703 ... 0

Copyright Wabco®	Signature	2011-10-11	BURMESTER
Year	Model	2011-10-11	CHRONIS
Scale	Scale	BURMESTER	
Material No.			
841 601 304 0			
ECS No.			
Pro/E			
Product Identification No.			
4990			

WABCO	
TRAILER - EBS E	
FOR 3-AXLES-CENTRE AXLE-TRAILERS	
AGRICULT. TRAILER W. HYDR. SUSPENSION	
PREV. ABS-2S/2M OR 4S/2M	
(MULTIVOLTAGE)	
Part. Reg.	002 EN 1/1

2.3 Drawbar trailer

AXLE(S)	ABS SYSTEM	NUMBER	TRISTOP™	OVERLOAD PROTECTION VALVE	PEM	MECHANICAL SUSPENSION	PREV	MODULATOR FRONT AXLE	COMMENT	PAGE
2	4S/3M	841 601 220 0	x				x	x		190
2	4S/3M	841 601 223 0	x	x			x	x		191
2	4S/3M	841 601 224 0	x		x		x			192
2	4S/3M	841 601 225 0	x		x	x	x			193
2	4S/3M	841 601 226 0								194
2	4S/3M	841 601 227 0	x	x		x	x	x		195
2	4S/3M	841 601 228 0						x		196
2	4S/3M	841 601 229 0	x	x			x			197
2	4S/3M	841 601 230 0	x				x			198
2	4S/3M	841 601 341 0	x		x		x	x		199
2	4S/3M	841 601 342 0	x							200
2	4S/3M	841 601 345 0	x				x			201
2	4S/3M	841 601 347 0				x				202
2	4S/3M	841 601 391 0	x	x			x	x	Additional trailer CAN router / Duo-Matic	203
3	4S/3M	841 601 230 0	x				x			204
3	4S/3M	841 601 231 0	x	x			x			205
3	4S/3M	841 601 232 0	x		x		x			206
3	4S/3M	841 601 233 0	x	x						207
3	4S/3M	841 601 235 0	x		x	x				208
3	4S/3M	841 601 236 0	x							209
3	4S/3M	841 601 237 0	x		x		x		Additional test valve (supply)	210
3	4S/3M	841 601 238 0	x			x			Duo-Matic	211
3	4S/3M	841 601 360 0						x	2 axles, front	212
3	4S/3M	841 601 361 0	x		x				2 axles, front	213
3	4S/3M	841 601 362 0				x				214
3	4S/3M	841 601 363 0	x	x		x	x			215
4	4S/3M	841 601 198 0	x		x		x		Steering axle 4	216
4	4S/3M	841 601 240 0	x	x			x			217
4	4S/3M	841 601 241 0	x	x			x	x		218
4	4S/3M	841 601 242 0	x				x			219
4	4S/3M	841 601 243 0	x			x		x		220
4	4S/3M	841 601 244 0	x		x		x			221
4	2x 4S/2M	841 601 245 0	x						CAN router 2x 4S/2M	222
4	4S/3M	841 601 246 0	x		x			x		223
4	4S/3M	841 601 247 0	x		x					224
4	4S/3M	841 601 249 0	x	x		x	x	x	Auxiliary relay / RSS	225
4	4S/3M	841 601 350 0	x	x			x	x	Auxiliary relay / RSS	226
4	4S/3M	841 601 351 0	x							227
4	4S/3M	841 601 352 0	x							228
5	4S/3M	841 601 063 0	x		x					229
5	4S/3M	841 601 064 0	x							230
5	4S/3M	841 601 065 0	x							231
5	4S/3M	841 601 066 0	x		x		x		Select Low axle 5	232
5	4S/3M	841 601 067 0	x		x		x		Tristop™ axle 2+3+4, steering axle 5	233
5	4S/3M	841 601 069 0	x		x		x		Auxiliary relay at front	234
5	4S/3M	841 601 380 0	x		x		x		Without relay at front, small brake cylinder	235

841 601 220 0

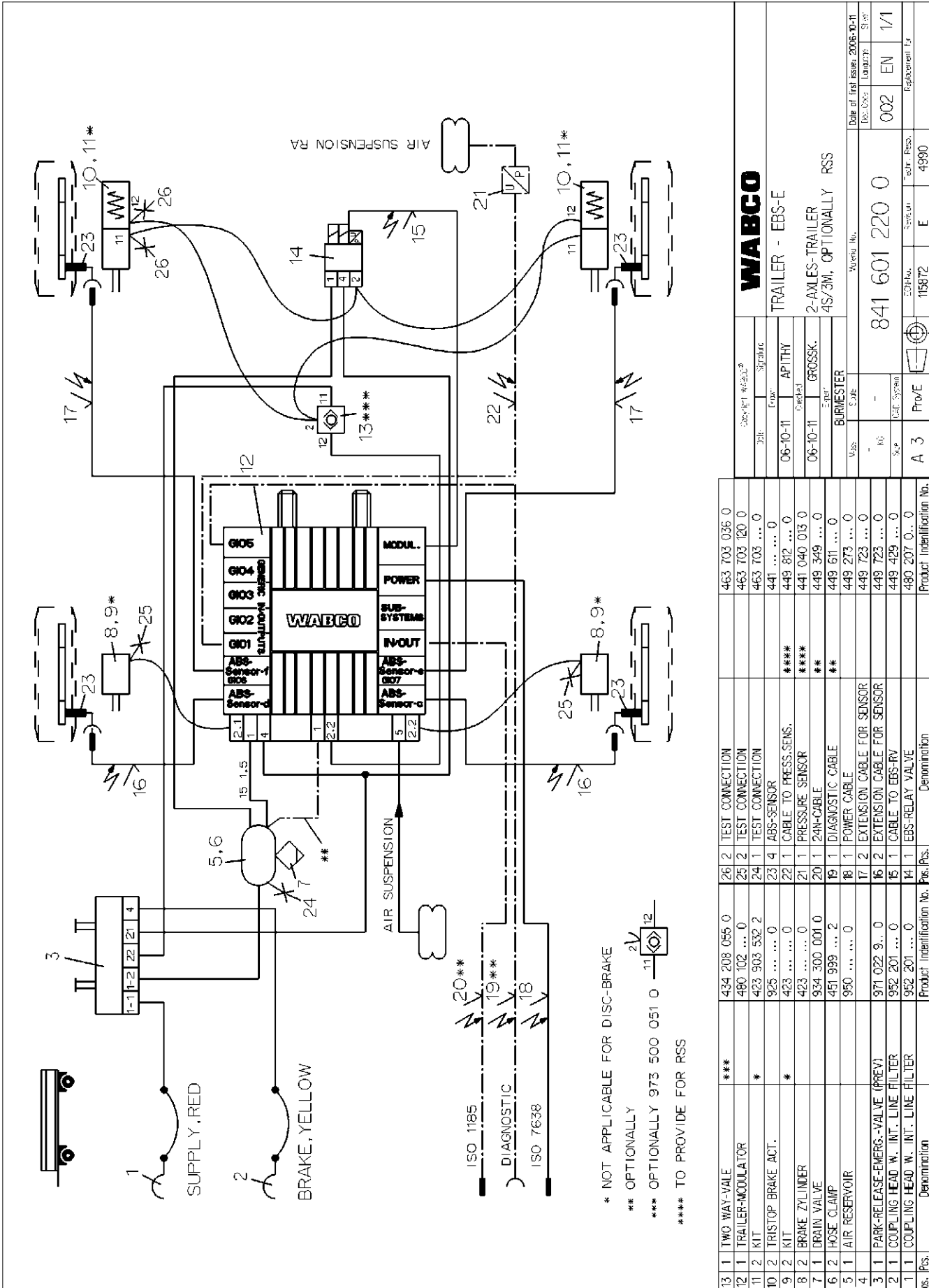

WABCO

TRAILER - EBS-E

2-AXLES-TRAILER
4S/3M; OPTIONALLY RSS

WABCO No. 841 601 220 0

Doc. Code: 002

Date of first issue: 2006-10-11

Language: EN

Page: 1/1

Order No.: 115872

Part No.: E

Part Name: 4990

Pos. / Pos.	Denomination	Product Identification No.	Pos. / Pos.	Denomination	Product Identification No.
13 1	TWO WAY-VALE	434 208 055 0	26 2	TEST CONNECTION	463 703 036 0
12 1	TRAILER-MODULATOR	480 102 ... 0	25 2	TEST CONNECTION	463 703 120 0
11 2	KIT	423 903 532 2	24 1	TEST CONNECTION	463 703 ... 0
10 2	TRISTOP BRAKE ACT.	925 ... 0	23 4	ABS-SENSOR	441 ... 0
9 2	KIT	423 ... 0	22 1	CABLE TO PRESS.SENS.	449 812 ... 0
8 2	BRAKE ZYLINDER	423 ... 0	21 1	PRESSURE SENSOR	441 040 013 0
7 1	DRAIN VALVE	934 300 001 0	20 1	2-IN-CABLE	449 349 ... 0
6 2	HOSE CLAMP	451 999 ... 2	19 1	DIAGNOSTIC CABLE	449 611 ... 0
5 1	AIR RESERVOIR	950 ... 0	18 1	POWER CABLE	449 273 ... 0
4			17 2	EXTENSION CABLE FOR SENSOR	449 723 ... 0
3 1	PARK-RELEASE-EMERG.-VALVE (PREV.)	971 022 9... 0	16 2	EXTENSION CABLE FOR SENSOR	449 723 ... 0
2 1	COUPLING HEAD W. INT. LINE FILTER	952 201 ... 0	15 1	CABLE TO EBS-RV	449 429 ... 0
1 1	COUPLING HEAD W. INT. LINE FILTER	952 201 ... 0	14 1	EBS-RELAY VALVE	480 207 0... 0

Braking diagrams Drawbar trailer

841 601 223 0

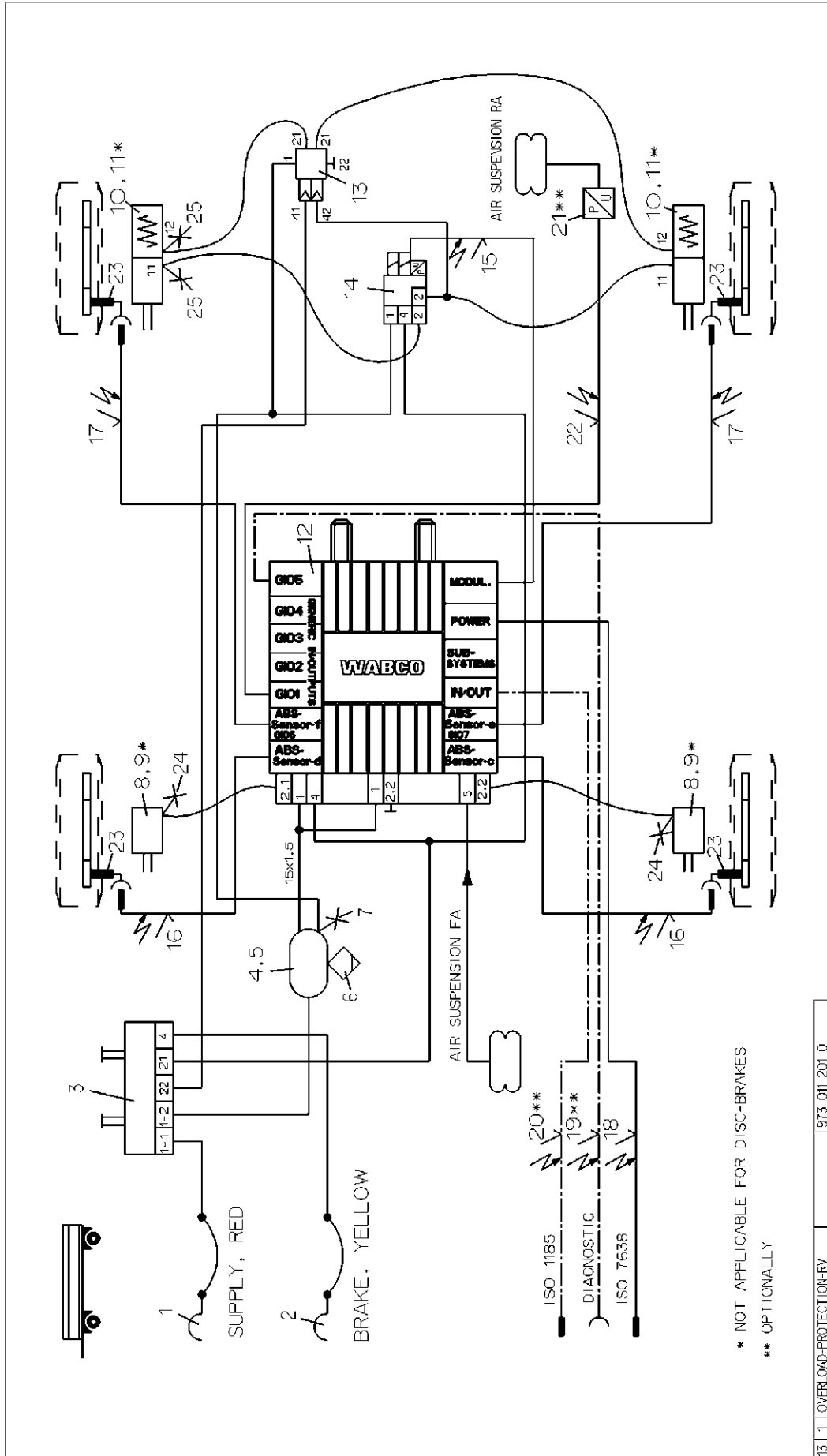

* NOT APPLICABLE FOR DISC-BRAKES
** OPTIONAL

Part No.		Description		Product Identification No.	Pos.	Pos.
15	1 OVERLOAD-PROTECTION-RV	973 011 201 0				
12	1 TRAILER-MODULATOR	480 102 ... 0				
11	2 KIT	423 903 532 2				
10	2 TRISTOP BRAKE ACTUATOR	925 0				
9	2 KIT	423 0				
8	2 BRAKE CHAMBER	423 0				
6	1 DRAIN VALVE	934 300 001 0				
5	1 HOSE CLAMP	451 999 ... 2				
4	1 AIR RESERVOIR	950 0				
3	1 PARK-RELEASE-EMERGENCY VALVE	971 002 9... 0				
2	1 COUPLING HEAD W. INT. LINE FILTER	952 201 ... 0				
1	1 COUPLING HEAD W. INT. LINE FILTER	952 201 ... 0				
Pos. Pos.	Denomination	Product Identification No.	Pos. Pos.	Denomination	Product Identification No.	

463 703 036 0		463 703 120 0
441 0		449 812 ... 0
441 040 013 0		449 349 ... 0
449 611 ... 0		449 273 ... 0
449 723 ... 0		449 723 ... 0
449 429 ... 0		480 207 0... 0

WABCO		TRAILER - EBS E	
		FOR 2-AXLES-TRAILER	
		4S/3M; AIR SUSPENSION WITH RSS	

Part No.	841 601 223 0	Revision	002	EN	1/1
Date of first issue: 2008-09-16					
Date of last update: 2008-09-16					
Request for					
4990					

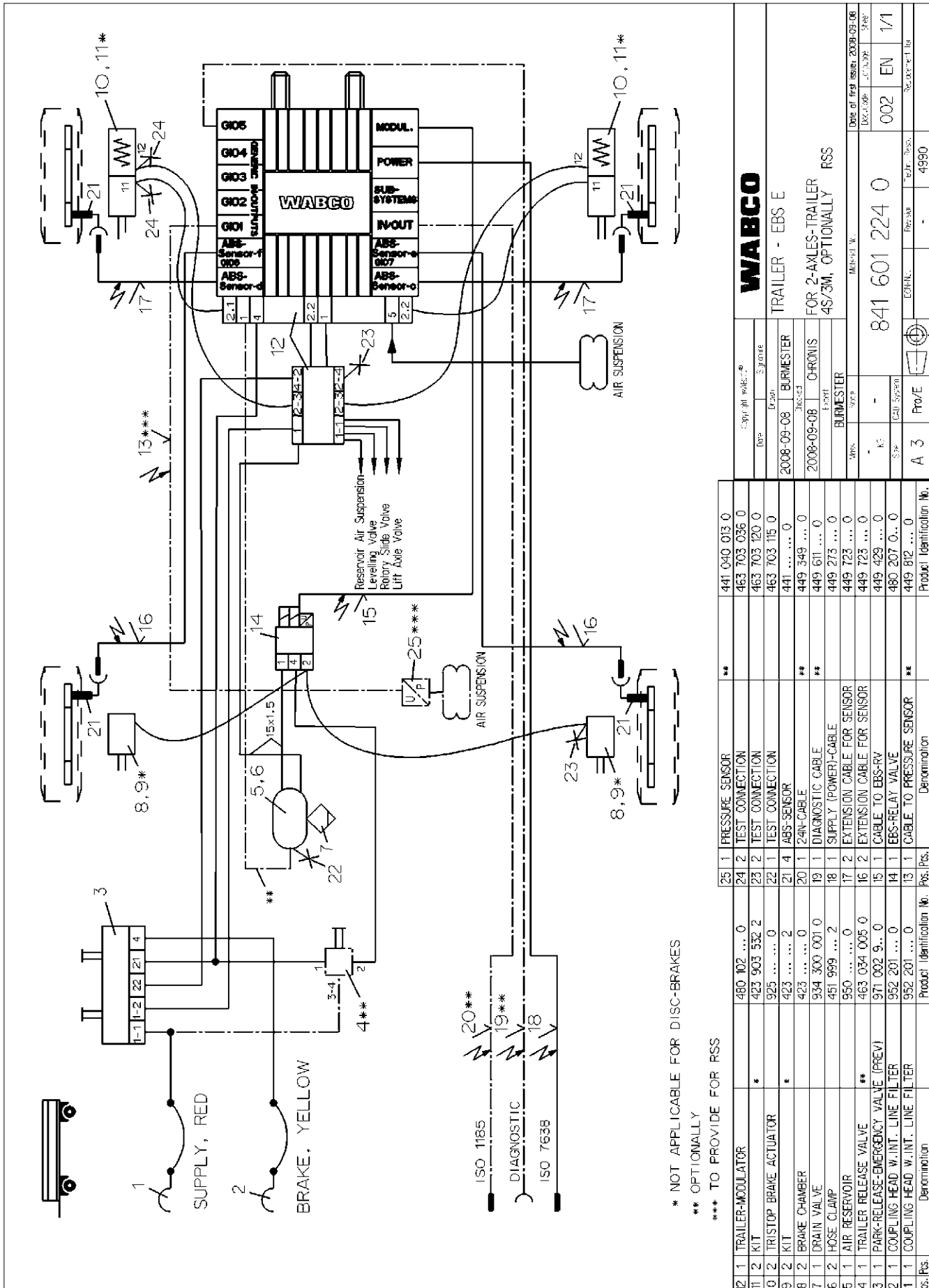

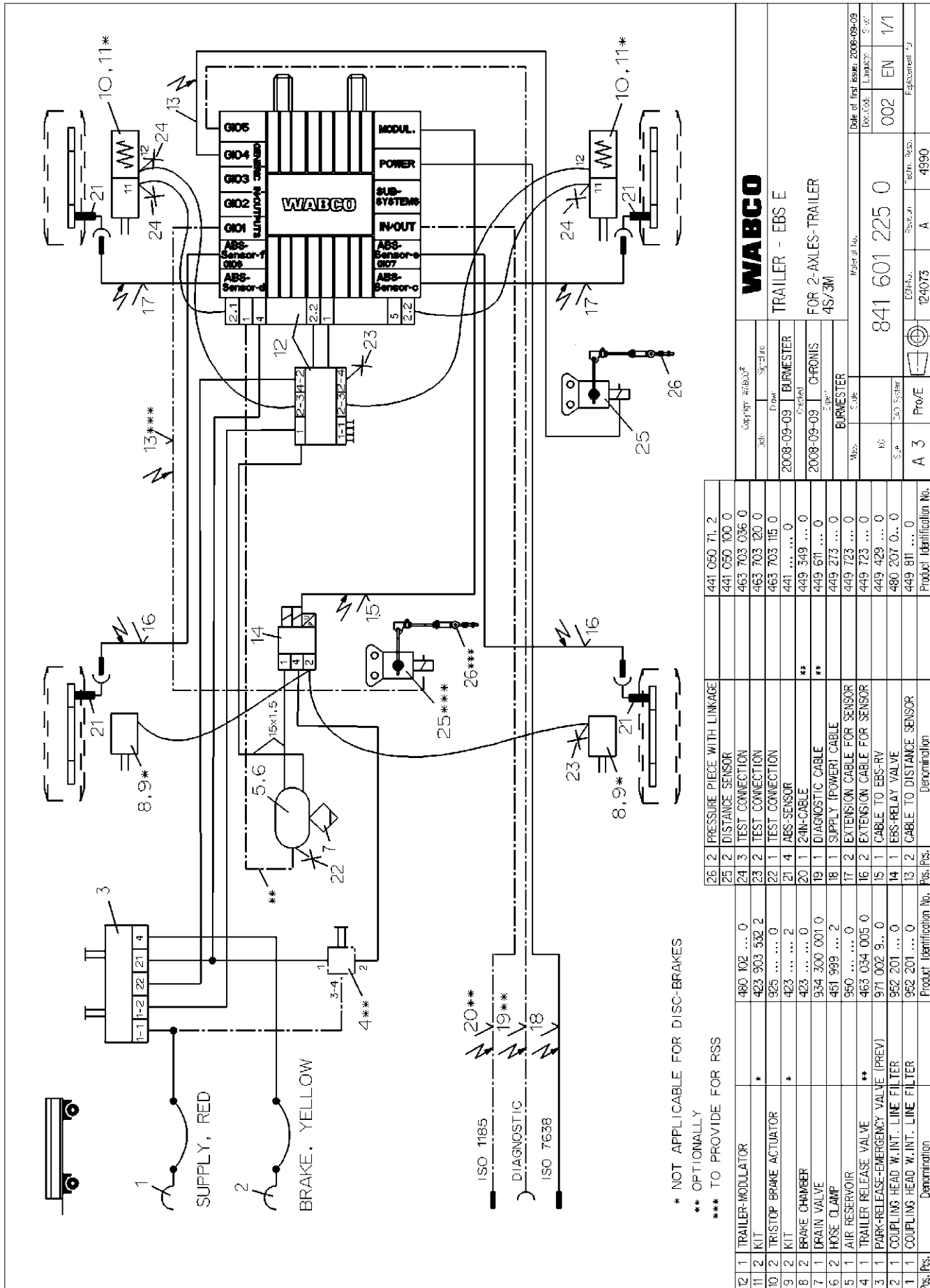

12 1 TRAILER-MODULATOR		441 050 71.2	Product Identification No.
11 2 KIT	480 102 ... 0	441 050 100 0	
10 2 TRISTOP BRAKE ACTUATOR	423 903 532 2	463 703 036 0	
9 2 KIT	925 0	463 703 20 0	
8 2 BRAKE CHAMBER	423 2	463 703 115 0	
7 1 DRAIN VALVE	423 0	441 0	
6 2 HOSE CLAMP	934 300 001 0	449 349 ... 0	
5 1 TRAILER RELEASE VALVE	451 999 ... 2	449 511 ... 0	
4 1 PARK-RELEASE-EMERGENCY VALVE (PREV)	950 0	449 273 ... 0	
3 1 COUPLING HEAD W.INT. LINE FILTER	463 034 005 0	449 723 ... 0	
2 1 COUPLING HEAD W.INT. LINE FILTER	971 002 9... 0	449 429 ... 0	
1 1 Denomination	952 201 ... 0	490 207 0... 0	
	952 201 ... 0	449 811 ... 0	
	Product Identification No.	Product Identification No.	
	Pos. Pos.	Pos. Pos.	
	Denomination	Denomination	
	4 3 Pro/E	124073 A	4990
	16	841 601 225 0	002 EN 1/1
	3.4	Material No.	Date of first issue: 2008-09-09
	1	841 601 225 0	Doc. Code Language
	2	TRAILER - EBS E	
	3	FOR 2-AXLES-TRAILER	
	4	4S/3M	
	5	BURMESTER	
	6	2008-09-09	
	7	BURMESTER	
	8	2008-09-09	
	9	CHRONIS	
	10	BURMESTER	
	11	2008-09-09	
	12	BURMESTER	
	13	2008-09-09	
	14	CHRONIS	
	15	BURMESTER	
	16	2008-09-09	
	17	BURMESTER	
	18	2008-09-09	
	19	CHRONIS	
	20	BURMESTER	
	21	2008-09-09	
	22	BURMESTER	
	23	2008-09-09	
	24	CHRONIS	
	25	BURMESTER	
	26	2008-09-09	
	27	CHRONIS	
	28	BURMESTER	
	29	2008-09-09	
	30	CHRONIS	
	31	BURMESTER	
	32	2008-09-09	
	33	CHRONIS	
	34	BURMESTER	
	35	2008-09-09	
	36	CHRONIS	
	37	BURMESTER	
	38	2008-09-09	
	39	CHRONIS	
	40	BURMESTER	
	41	2008-09-09	
	42	CHRONIS	
	43	BURMESTER	
	44	2008-09-09	
	45	CHRONIS	
	46	BURMESTER	
	47	2008-09-09	
	48	CHRONIS	
	49	BURMESTER	
	50	2008-09-09	
	51	CHRONIS	
	52	BURMESTER	
	53	2008-09-09	
	54	CHRONIS	
	55	BURMESTER	
	56	2008-09-09	
	57	CHRONIS	
	58	BURMESTER	
	59	2008-09-09	
	60	CHRONIS	
	61	BURMESTER	
	62	2008-09-09	
	63	CHRONIS	
	64	BURMESTER	
	65	2008-09-09	
	66	CHRONIS	
	67	BURMESTER	
	68	2008-09-09	
	69	CHRONIS	
	70	BURMESTER	
	71	2008-09-09	
	72	CHRONIS	
	73	BURMESTER	
	74	2008-09-09	
	75	CHRONIS	
	76	BURMESTER	
	77	2008-09-09	
	78	CHRONIS	
	79	BURMESTER	
	80	2008-09-09	
	81	CHRONIS	
	82	BURMESTER	
	83	2008-09-09	
	84	CHRONIS	
	85	BURMESTER	
	86	2008-09-09	
	87	CHRONIS	
	88	BURMESTER	
	89	2008-09-09	
	90	CHRONIS	
	91	BURMESTER	
	92	2008-09-09	
	93	CHRONIS	
	94	BURMESTER	
	95	2008-09-09	
	96	CHRONIS	
	97	BURMESTER	
	98	2008-09-09	
	99	CHRONIS	
	100	BURMESTER	

* NOT APPLICABLE FOR DISC-BRAKES
 ** OPTIONALLY
 *** TO PROVIDE FOR RSS

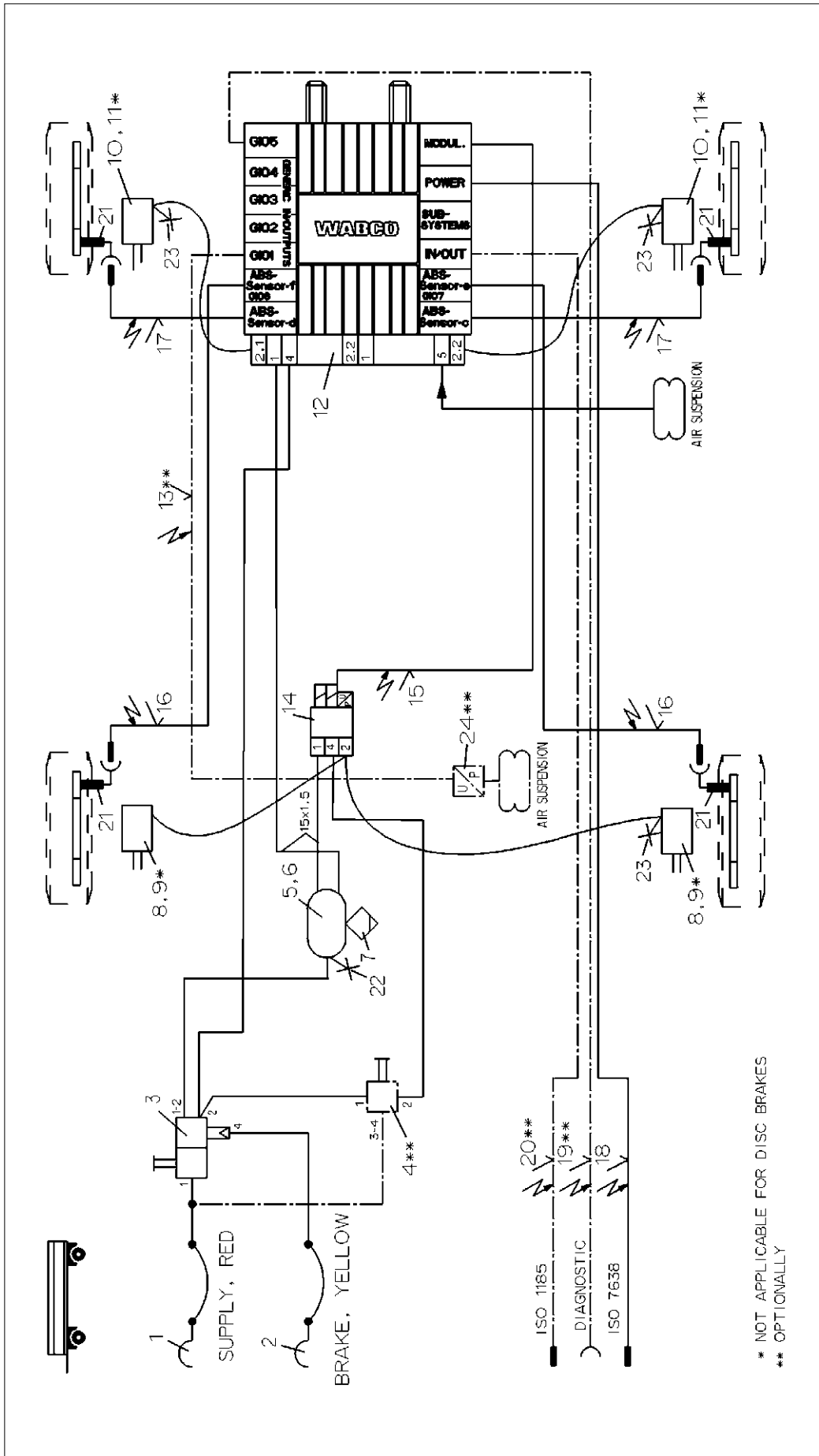

* NOT APPLICABLE FOR DISC BRAKES
 ** OPTIONALLY

Part No.		Description		Quantity		Unit		Material No.		Revision	
12	1	TRAILER-MODULATOR	480 102 ... 0	24	1	PRESSURE SENSOR	441 040 013 0	2010-09-29	BURMESTER	Scale	841 601 226 0
11	2	KIT	423 903 532 2	23	3	TEST CONNECTION	463 703 120 0	2010-09-29	BURMESTER	Scale	002 EN 1/1
10	2	BRAKE CHAMBER	423 ... 0	22	1	TEST CONNECTION	463 703 115 0	2010-09-29	BURMESTER	Scale	002 EN 1/1
9	2	KIT	423 ... 2	21	4	ABS-SENSOR	441 ... 0	2010-09-29	BURMESTER	Scale	002 EN 1/1
8	2	BRAKE CHAMBER	423 ... 0	20	1	24N-CABLE	449 349 ... 0	2010-09-29	BURMESTER	Scale	002 EN 1/1
7	1	DRAIN VALVE	934 300 001 0	19	1	DIAGNOSTIC CABLE	449 611 ... 0	2010-09-29	BURMESTER	Scale	002 EN 1/1
6	2	HOSE CLAMP	451 999 ... 2	18	1	SUPPLY (POWER) CABLE	449 273 ... 0	2010-09-29	BURMESTER	Scale	002 EN 1/1
5	1	AIR RESERVOIR	950 ... 0	17	2	EXTENSION CABLE FOR SENSOR	449 723 ... 0	2010-09-29	BURMESTER	Scale	002 EN 1/1
4	1	TRAILER RELEASE VALVE	463 034 005 0	16	2	EXTENSION CABLE FOR SENSOR	449 723 ... 0	2010-09-29	BURMESTER	Scale	002 EN 1/1
3	1	TRAILER-BRAKE VALVE W. RELEASE VALVE	971 002 7... 0	15	1	CABLE TO EBS-RV	449 429 ... 0	2010-09-29	BURMESTER	Scale	002 EN 1/1
2	1	COUPLING HEAD W. INT. LINE FILTER	952 201 ... 0	14	1	EBS-RELAY VALVE	480 207 0... 0	2010-09-29	BURMESTER	Scale	002 EN 1/1
1	1	COUPLING HEAD W. INT. LINE FILTER	952 201 ... 0	13	1	CABLE TO PRESSURE SENSOR	449 812 ... 0	2010-09-29	BURMESTER	Scale	002 EN 1/1

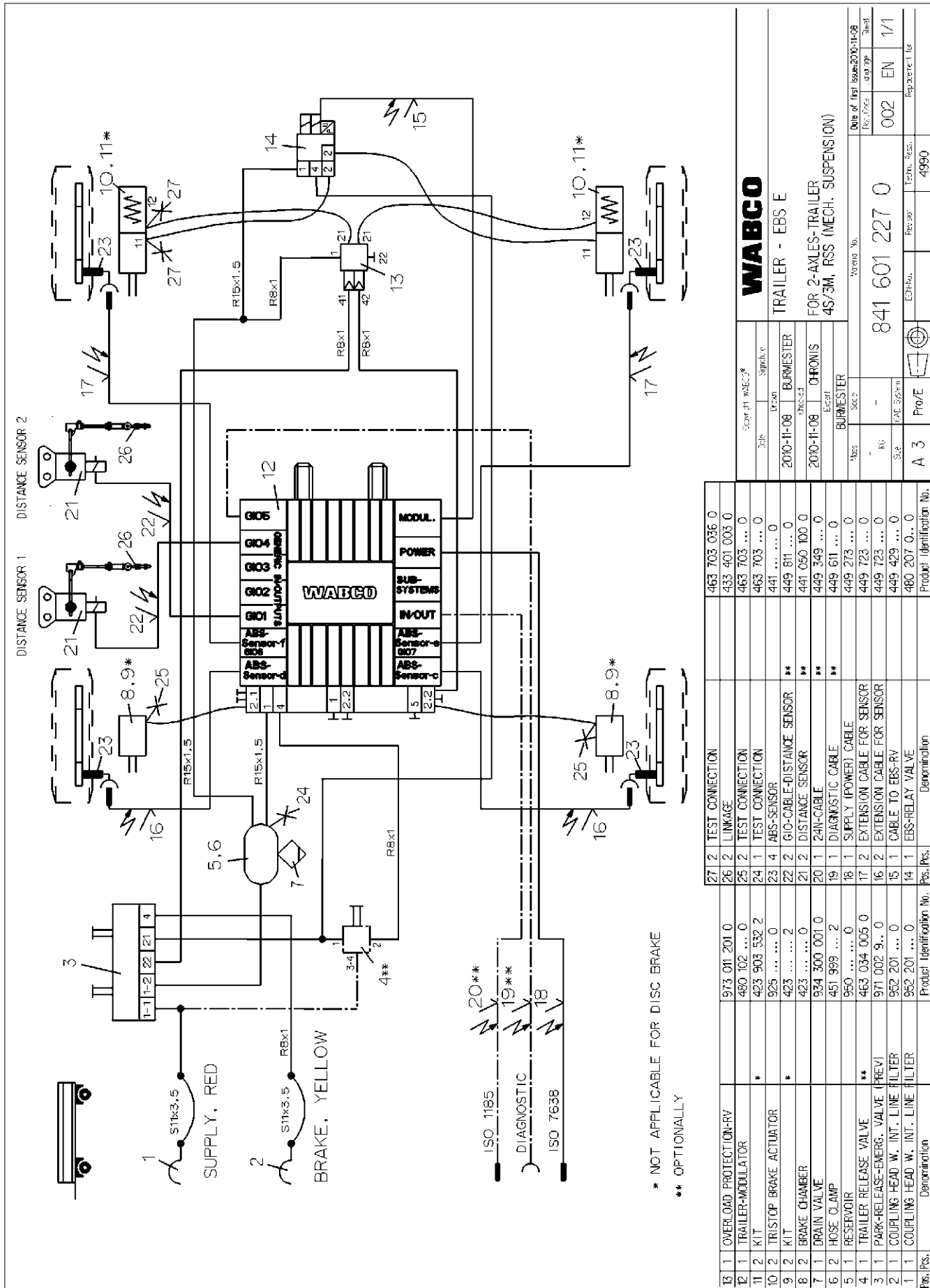

* NOT APPLICABLE FOR DISC BRAKE
** OPTIONALLY

Fig. Pos.	Denomination	Product Identification No.	Pos. Pos.	Denomination	Product Identification No.
13 1	OVERLOAD PROTECTION-RV	973 011 201 0	27 2	TEST CONNECTION	463 703 036 0
12 1	TRAILER-MODULATOR	480 102 ... 0	26 2	LINKAGE	433 401 003 0
11 2	KIT	423 903 532 2	25 2	TEST CONNECTION	463 703 ... 0
10 2	TRISTOP BRAKE ACTUATOR	925 0	24 1	TEST CONNECTION	463 703 ... 0
9 2	KIT	423 2	23 4	ABS-SENSOR	441 0
8 2	BRAKE CHAMBER	423 0	22 2	GIO-CABLE-DISTANCE SENSOR	449 611 ... 0
7 1	DRAIN VALVE	934 300 001 0	21 2	DISTANCE SENSOR	441 050 100 0
6 2	HOSE CLAMP	451 989 ... 2	20 1	24N-CABLE	449 349 ... 0
5 1	RESERVOIR	950 0	19 1	DIAGNOSTIC CABLE	449 611 ... 0
4 1	TRAILER RELEASE VALVE	463 034 005 0	18 1	SUPPLY (POWER) CABLE	449 273 ... 0
3 1	PARK-RELEASE-EMERG. VALVE (PREV)	971 002 9... 0	17 2	EXTENSION CABLE FOR SENSOR	449 723 ... 0
2 1	COUPLING HEAD W. INT. LINE FILTER	952 201 ... 0	16 2	EXTENSION CABLE FOR SENSOR	449 723 ... 0
1 1	COUPLING HEAD W. INT. LINE FILTER	952 201 ... 0	15 1	CABLE TO EBS-RV	449 429 ... 0
			14 1	EBS-RELAY VALVE	480 207 0... 0

WABCO

TRAILER - EBS E
FOR 2-AXLES-TRAILER
4S/3M, RSS (MECH. SUSPENSION)

Version No. 841 601 227 0
Reg. Price EN 1/1
Reg. No. 4990

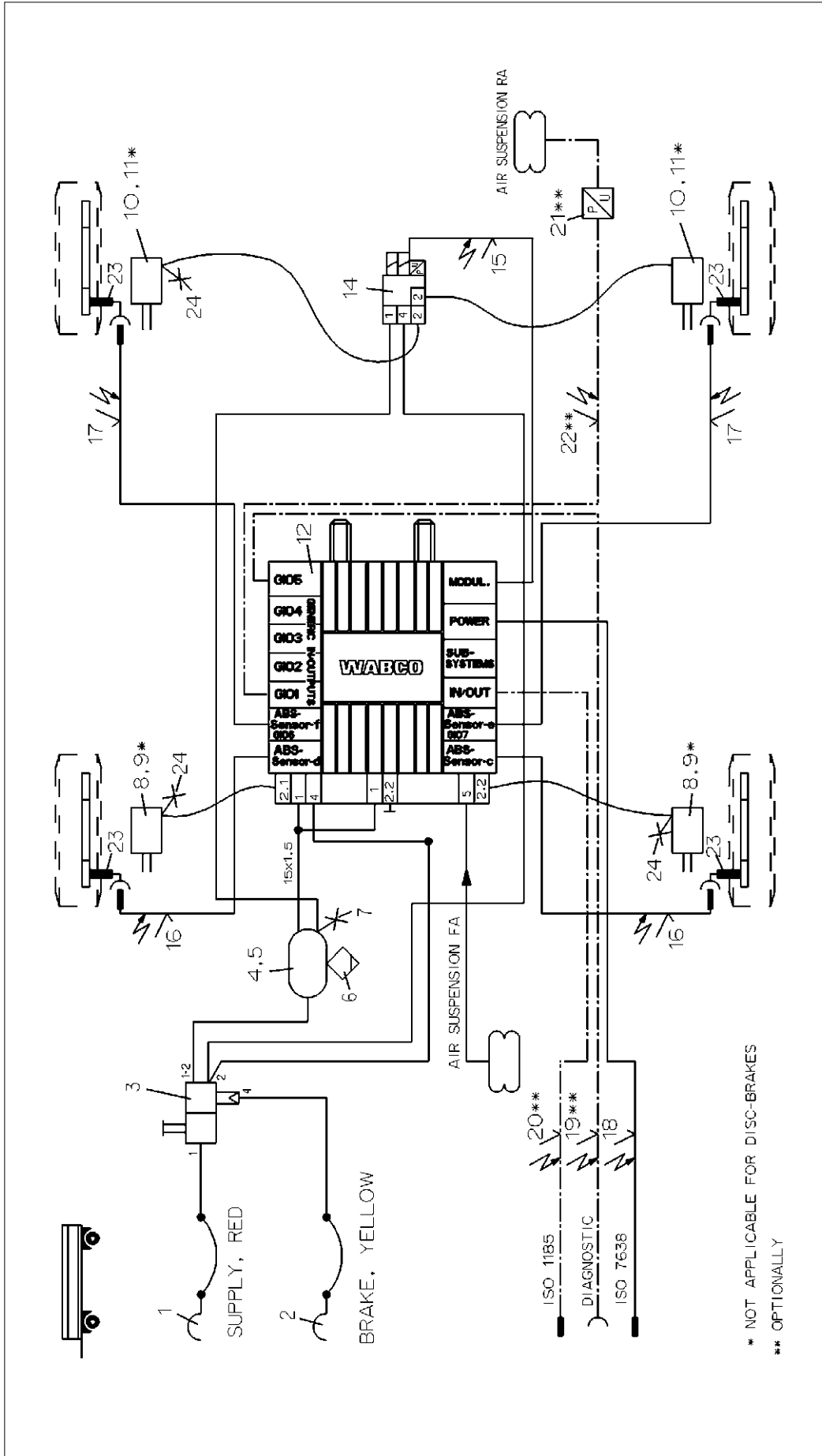

* NOT APPLICABLE FOR DISC-BRAKES
 ** OPTIONALLY

12	1	TRAILER-MODULATOR	480 102 ... 0	24	3	TEST CONNECTION	463 703 120 0
11	2	KIT	423 2	23	4	ABS-SENSOR	441 0
10	2	BRAKE CHAMBER	423 0	22	1	CABLE TO PRESSURE SENSOR	449 812 ... 0
9	2	KIT	423 2	21	1	PRESSURE SENSOR	441 040 013 0
8	2	BRAKE CHAMBER	423 0	20	1	24V-CABLE	449 349 ... 0
7	1	TEST CONNECTION	463 703 ... 0	19	1	DIAGNOSTIC CABLE	449 611 ... 0
6	1	DRAIN VALVE	934 300 001 0	18	1	SUPPLY (POWER) CABLE	449 273 ... 0
5	2	HOSE CLAMP	451 999 ... 2	17	2	EXTENSION CABLE FOR SENSOR	449 723 ... 0
4	1	AIR RESERVOIR	950 0	16	2	EXTENSION CABLE FOR SENSOR	449 723 ... 0
3	1	LAH. BREMSVENTIL MIT LOSSEVENTIL	971 002 703 0	15	1	CABLE TO EBS-RV	449 429 ... 0
2	1	COUPLING HEAD W. INT. LINE FILTER	952 201 ... 0	14	1	EBS-RELAY VALVE	480 207 0.. 0
1	1	COUPLING HEAD W. INT. LINE FILTER	952 201 ... 0	13			

Date of first issue: 2009-03-02	
Doc. Code	002 EN 1/1
Doc. Code	002 EN 1/1
Doc. Code	002 EN 1/1

Part No.	841 601 228 0	Part No.	4990
Part No.	841 601 228 0	Part No.	4990
Part No.	841 601 228 0	Part No.	4990

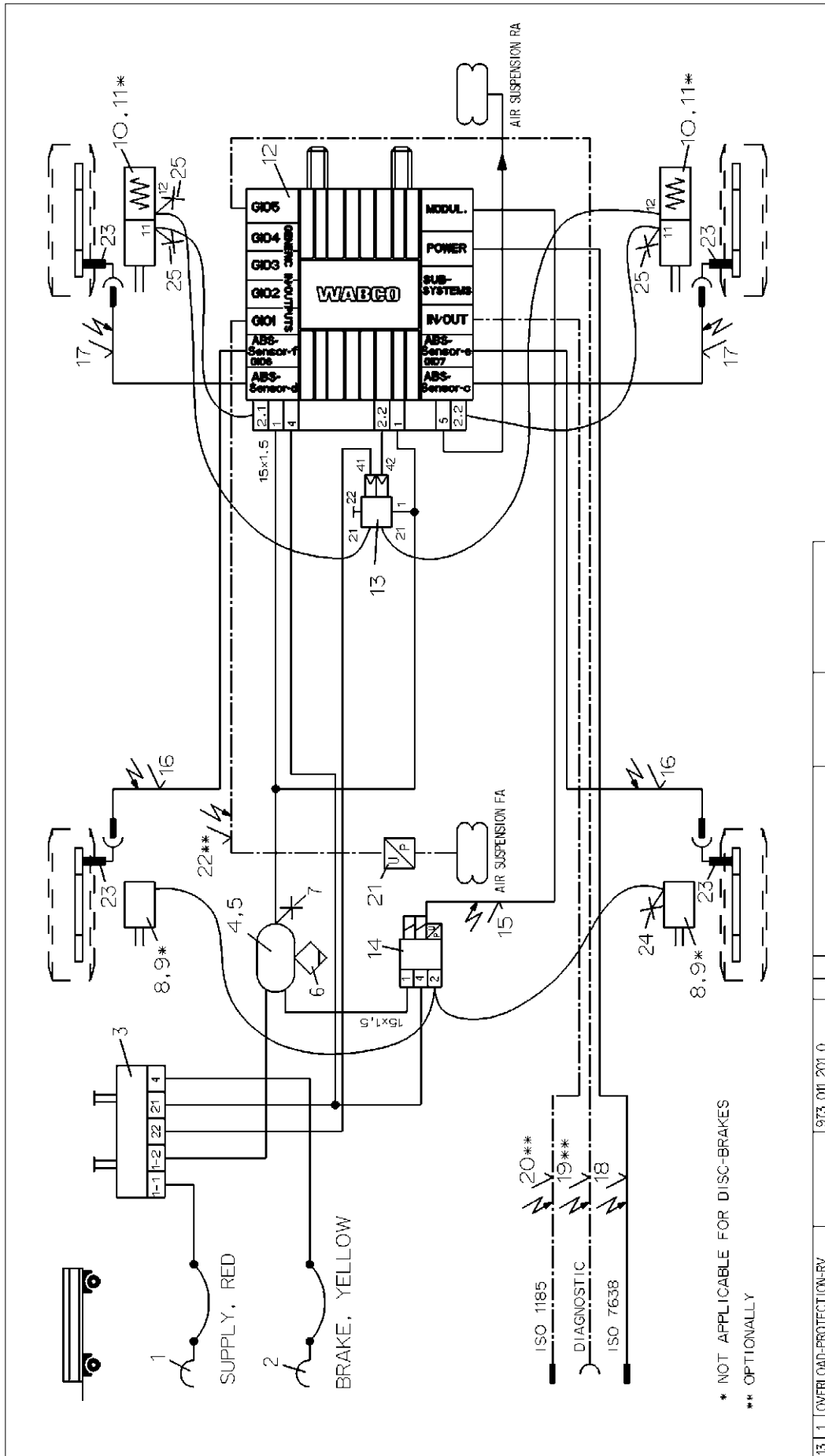

* NOT APPLICABLE FOR DISC-BRAKES
 ** OPTIONALLY

973 011 201 0		25 3	TEST CONNECTION	463 703 036 0
13 1	OVERLOAD-PROTECTION-RV	25 3	TEST CONNECTION	463 703 120 0
12 1	TRAILER-MODULATOR	24 1	TEST CONNECTION	441 0
11 2	KIT	23 4	ABS-SENSOR	449 812 ... 0
10 2	TRISTOP BRAKE ACTUATOR	22 1	CABLE TO PRESSURE SENSOR	441 040 013 0
9 2	KIT	21 1	PRESSURE SENSOR	449 349 ... 0
8 2	BRAKE CHAMBER	20 1	24N-CABLE	449 611 ... 0
7 1	TEST CONNECTION	19 1	DIAGNOSTIC CABLE	449 273 ... 0
6 1	DRAIN VALVE	18 1	SUPPLY (POWER) CABLE	449 723 ... 0
5 2	HOSE CLAMP	17 2	EXTENSION CABLE FOR SENSOR	449 723 ... 0
4 1	AIR RESERVOIR	16 2	EXTENSION CABLE FOR SENSOR	449 429 ... 0
3 1	PARK-RELEASE-EMERGENCY VALVE (PREV)	15 1	CABLE TO EBS-RV	480 207 0... 0
2 1	COUPLING HEAD W/INT. LINE FILTER	14 1	EBS-RELAY VALVE	
1 1	COUPLING HEAD W/INT. LINE FILTER			

973 011 201 0		Date of first issue: 2009-04-20	
480 102 ... 0		Doc. Code: 414.000	
423 903 532 2		Sheet: 002	
925 2		EN 1/1	
423 2		Replacement for	
423 0			
463 703 ... 0			
924 300 001 0			
491 999 ... 2			
950 0			
971 002 9... 0			
952 201 ... 0			
952 201 ... 0			

Product Identification No.		841 601 229 0	
Denomination		TRAILER - EBS E	
Pos. Pos.		FOR 2-AXLES-TRAILER	
Pos. Pos.		4S/3M	
Pos. Pos.		BURNESTER	
Pos. Pos.		Date of first issue: 2009-04-20	
Pos. Pos.		Doc. Code: 414.000	
Pos. Pos.		Sheet: 002	
Pos. Pos.		EN 1/1	
Pos. Pos.		Replacement for	
Pos. Pos.		4990	

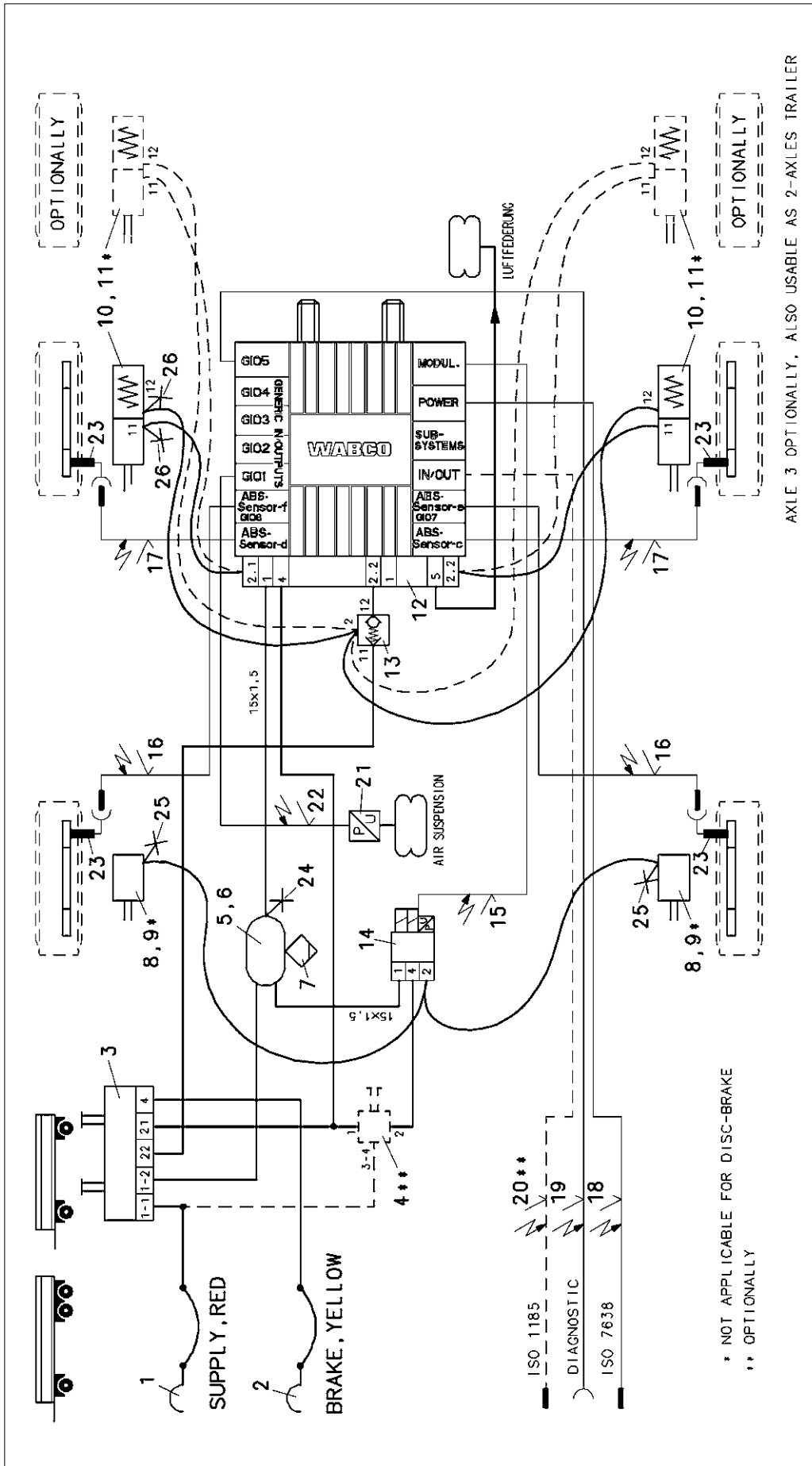

AXLE 3 OPTIONALLY, ALSO USABLE AS 2-AXLES TRAILER

* NOT APPLICABLE FOR DISC-BRAKE
** OPTIONALLY

13	1	TWO WAY-VALVE	434 208 055 0	25	2	TEST CONNECTION	463 703 036 0
12	1	TRAILER-MODULATOR	480 102 ... 0	25	2	TEST CONNECTION	463 703 120 0
11	2	BEIPACK	423 903 532 2	24	1	TEST CONNECTION	463 703 ... 0
10	2	TRISTOP BRAKE ACT.	925 0	23	4	ABS-SENSOR	441 0
9	2	IKIT	423 2	22	1	CABLE TO PRESS.SENS.	449 872 ... 0
8	2	BRAKE CHAMBER	423 0	21	1	PRESSURE SENSOR	441 040 013 0
7	1	DRAIN VALVE	934 300 001 0	20	1	24N-CABLE	449 349 000 0
6	2	HOSE CLAMP	451 999 ... 2	19	1	DIAGNOSTIC CABLE	449 611 000 0
5	1	AIR RESERVOIR	950 0	18	1	SUPPLY(POWER)-CABLE	449 273 000 0
4	1	TRAIL.-RELEASE VALVE	463 034 005 0	17	2	EXTENSION CABLE	449 723 000 0
3	1	PARK-RELEASE-EMERG.- VALVE (PREV)	971 002 9 ... 0	16	2	EXTENSION CABLE	449 723 000 0
2	1	COUPLING HEAD W. INT. LINE FILTER	952 201 003 0	15	1	CABLE TO EBS-RV	449 429 000 0
1	1	COUPLING HEAD W. INT. LINE FILTER	952 201 004 0	14	1	EBS-RELAY VALVE	480 207 0 ... 0
FIG. NOS.		DENOMINATION	FIG. NOS.		DENOMINATION	FIG. NOS.	DATE
			463 703 036 0				
			463 703 120 0				
			463 703 ... 0				
			441 0				
			449 872 ... 0				
			441 040 013 0				
			449 349 000 0				
			449 611 000 0				
			449 273 000 0				
			449 723 000 0				
			449 723 000 0				
			449 429 000 0				
			480 207 0 ... 0				
			114843 B				07-10-19
			480 207 0 ... 0				112957 A
			112957 A				07-04-05
			PRODUCT IDENTIFICATION NO.				DATE
			171				
			841 601 230 0				
			CODE FOR SHAPE				
			3124				
			CODE FOR FUNCTION				
			A 3				
			CODE FOR REPLACEMENT SHEET				
			002en				
			01				
			REPLACEMENT FOR				
			TRAILER - EBS-E				
			FOR 2-AND 3-AXLES-TRAILER				
			4S/3M				
			-RSS-				
			PRODUCT IDENTIFICATION NO.				
			171				
			841 601 230 0				
			CODE FOR SHAPE				
			3124				
			CODE FOR FUNCTION				
			A 3				
			CODE FOR REPLACEMENT SHEET				
			002en				
			01				
			REPLACEMENT FOR				
			TRAILER - EBS-E				
			FOR 2-AND 3-AXLES-TRAILER				
			4S/3M				
			-RSS-				

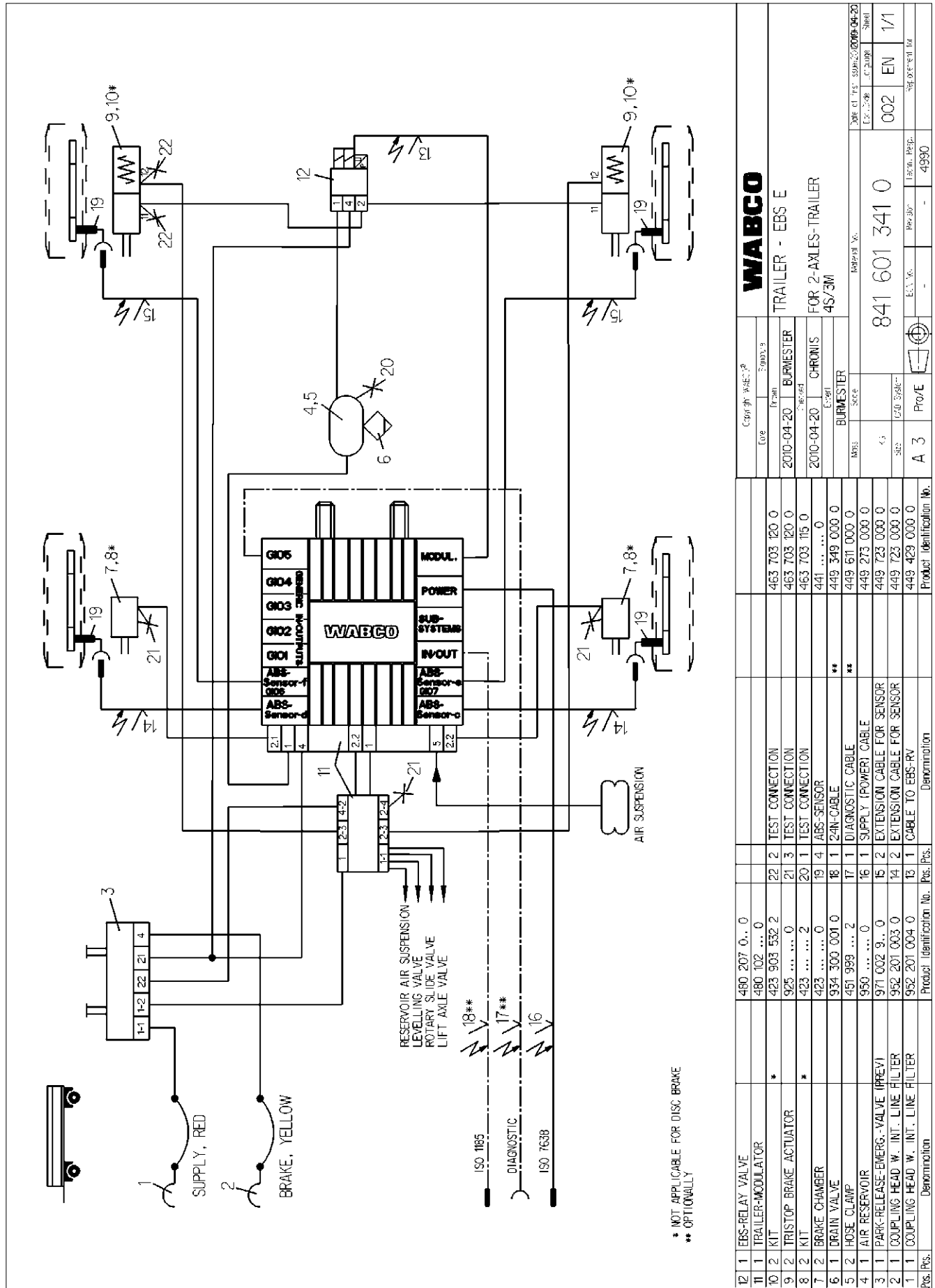

Pos. Pos.	Denomination	Product. Identification No.	Pos. Pos.	Denomination	Product. Identification No.
12 1	EBS-RELAY VALVE	480 207 0.. 0			
11 1	TRAILER-MODULATOR	480 102 ... 0			
10 2	KIT	423 903 532 2	22 2	TEST CONNECTION	463 703 120 0
9 2	TRISTOP BRAKE ACTUATOR	925 0	21 3	TEST CONNECTION	463 703 120 0
8 2	KIT	423 2	20 1	TEST CONNECTION	463 703 115 0
7 2	BRAKE CHAMBER	423 0	19 4	ABS-SENSOR	441 0
6 1	DRAIN VALVE	934 300 001 0	18 1	DIAGNOSTIC CABLE	449 349 000 0
5 2	AIR RESERVOIR	451 999 ... 2	17 1	SUPPLY (POWER) CABLE	449 611 000 0
4 1	PARK-RELEASE-EMERG.-VALVE (PREV1)	950 0	16 1	EXTENSION CABLE FOR SENSOR	449 723 000 0
3 1	COUPLING HEAD W. INT. LINE FILTER	952 201 003 0	15 2	EXTENSION CABLE FOR SENSOR	449 723 000 0
2 1	COUPLING HEAD W. INT. LINE FILTER	952 201 004 0	14 2	CABLE TO EBS-RV	449 429 000 0
1 1	Denomination		13 1	Product. Identification No.	

Copyright WABCO	Year	From	To
	2010-04-20	BURMESTER	2010-04-20
	2010-04-20	CHRONIS	2010-04-20

Material No.	Part No.	Rev. No.	Part No.	Rev. No.
841 601 341 0	002	EN	1/1	

Material No.	Part No.	Rev. No.	Part No.	Rev. No.
841 601 341 0	002	EN	1/1	

Material No.	Part No.	Rev. No.	Part No.	Rev. No.
841 601 341 0	002	EN	1/1	

Material No.	Part No.	Rev. No.	Part No.	Rev. No.
841 601 341 0	002	EN	1/1	

Material No.	Part No.	Rev. No.	Part No.	Rev. No.
841 601 341 0	002	EN	1/1	

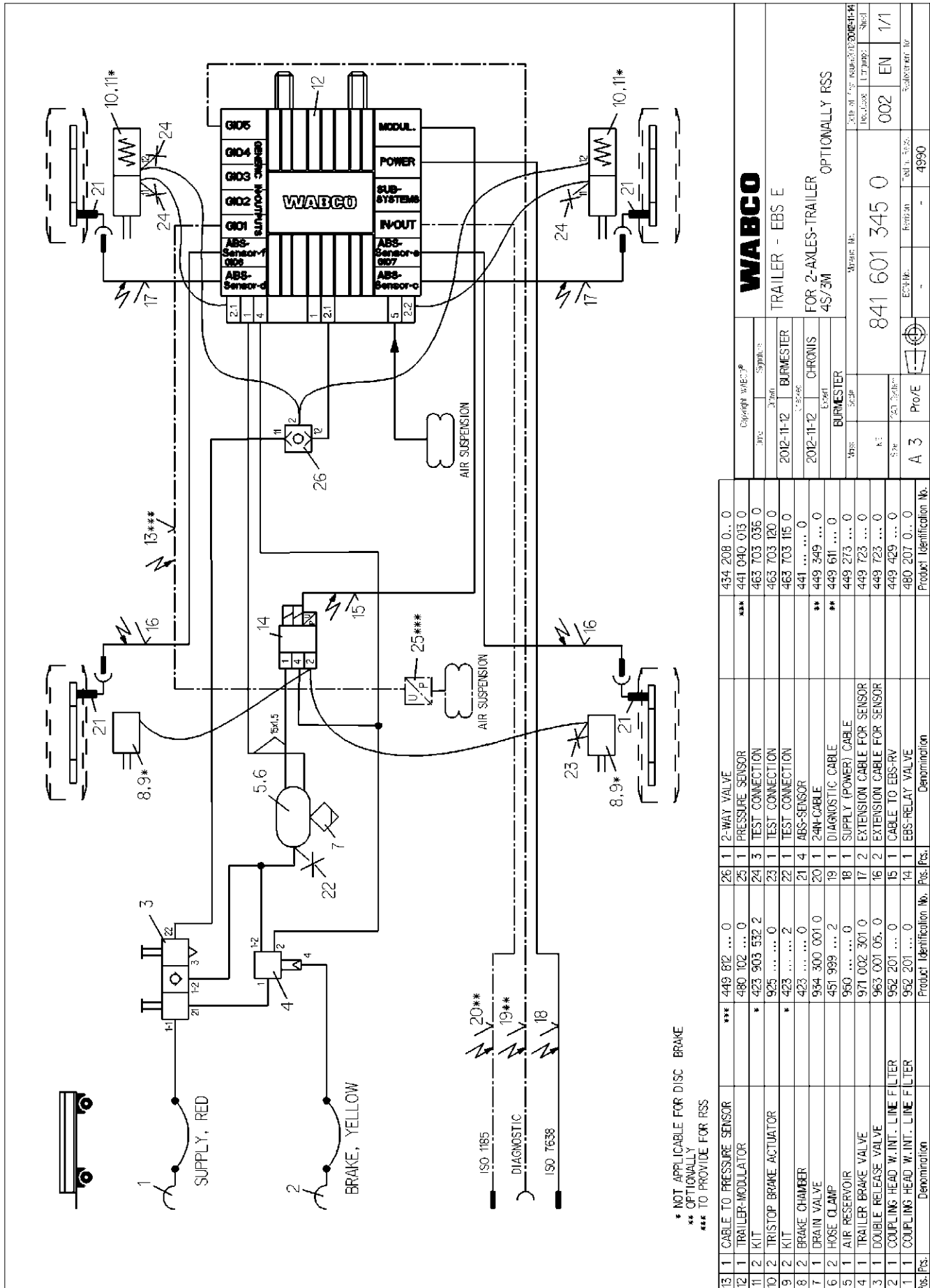

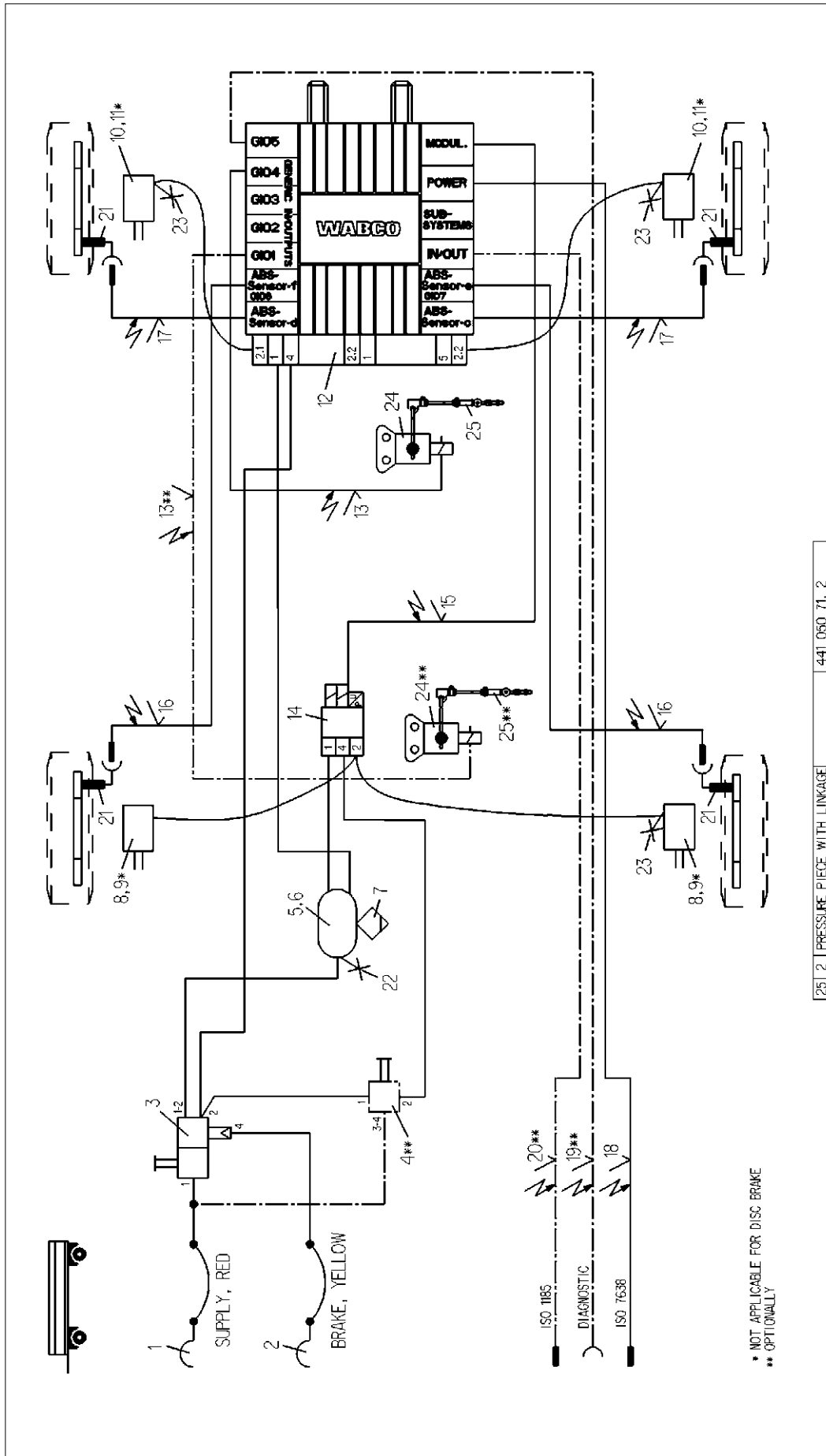

* NOT APPLICABLE FOR DISC BRAKE
 ** OPTIONAL

Product Identification No.		Denomination	
12	1	TRAILER-MODULATOR	441 050 71. 2
11	2	KIT	441 050 100 0
10	2	BRAKE CHAMBER	463 703 120 0
9	2	BRAKE CHAMBER	463 703 115 0
8	2	BRAKE CHAMBER	441 0
7	1	DRAIN VALVE	449 349 ... 0
6	2	HOSE CLAMP	449 611 ... 0
5	1	AIR RESERVOIR	449 273 ... 0
4	1	TRAILER RELEASE VALVE	449 723 ... 0
3	1	TRAILER-BRAKE VALVE W. RELEASE VALVE	449 723 ... 0
2	1	COUPLING HEAD W. INT. LINE FILTER	449 429 ... 0
1	1	COUPLING HEAD W. INT. LINE FILTER	480 207 0.. 0
Pos. Pos.	Pos. Pos.	Product Identification No.	Denomination
25	2	PRESSURE PIECE WITH LINKAGE	441 050 71. 2
24	2	DISTANCE SENSOR	441 050 100 0
23	3	TEST CONNECTION	463 703 120 0
22	1	TEST CONNECTION	463 703 115 0
21	4	ABS-SENSOR	441 0
20	1	24V-CABLE	449 349 ... 0
19	1	DIAGNOSTIC CABLE	449 611 ... 0
18	1	SUPPLY (POWER) CABLE	449 273 ... 0
17	2	EXTENSION CABLE FOR SENSOR	449 723 ... 0
16	2	EXTENSION CABLE FOR SENSOR	449 723 ... 0
15	1	CABLE TO EBS-RV	449 429 ... 0
14	1	EBS-RELAY VALVE	480 207 0.. 0
13	2	CABLE TO DISTANCE SENSOR	449 811 ... 0
Pos. Pos.	Pos. Pos.	Product Identification No.	Denomination
25	2	PRESSURE PIECE WITH LINKAGE	441 050 71. 2
24	2	DISTANCE SENSOR	441 050 100 0
23	3	TEST CONNECTION	463 703 120 0
22	1	TEST CONNECTION	463 703 115 0
21	4	ABS-SENSOR	441 0
20	1	24V-CABLE	449 349 ... 0
19	1	DIAGNOSTIC CABLE	449 611 ... 0
18	1	SUPPLY (POWER) CABLE	449 273 ... 0
17	2	EXTENSION CABLE FOR SENSOR	449 723 ... 0
16	2	EXTENSION CABLE FOR SENSOR	449 723 ... 0
15	1	CABLE TO EBS-RV	449 429 ... 0
14	1	EBS-RELAY VALVE	480 207 0.. 0
13	2	CABLE TO DISTANCE SENSOR	449 811 ... 0
Pos. Pos.	Pos. Pos.	Product Identification No.	Denomination

WABCO
 TRAILER - EBS E
 FOR 2-AXLES-TRAILER
 4S/3M

2013-01-29 BURMESTER
 2013-01-29 CHRONIS
 BURMESTER

841 601 347 0

002 EN 1/1

4990

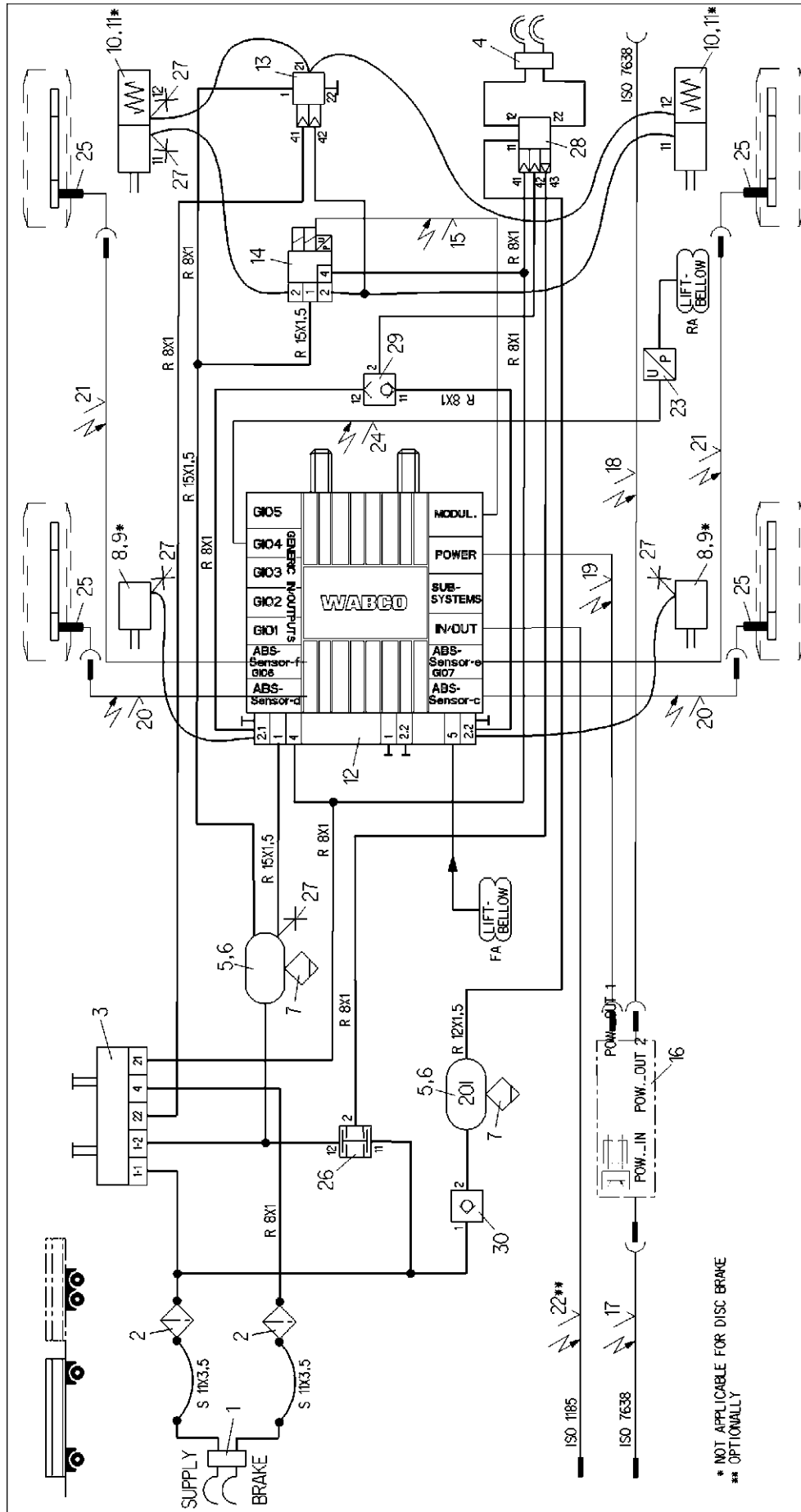

Pos. No.	Denomination	Product Identification No.	Pos. Pos.	Denomination	Product Identification No.
15	1 CABLE TO EBS-RELAY VALVE	449 429 ... 0	30	1 CHECK VALVE	441 014 000 0
14	1 EBS-RELAY VALVE	480 207 001 0	29	1 TWO WAY VALVE	434 208 029 0
13	1 OVERLOAD-PROTECTION-RV	973 011 201 0	28	1 TRAILER CONTROL VALVE	973 009 002 0
12	1 TRAILER INDUCTOR	480 102 ... 0	27	5 TEST CONNECTION	463 703 ... 0
11	2 KIT	423 903 532 2	26	1 DOUBLE SHUT-OFF-VALVE	434 500 003 0
10	2 TRISTOP BRAKE ACTUATOR	925 ... 0	25	4 ABS-SENSOR	441 ... 0
9	2 KIT	423 ... 2	24	1 GIO-CABLE-PRESS-SENSOR	449 812 1.. 0
8	2 BRAKE CHAMBER	423 ... 0	23	1 PRESSURE SENSOR	441 040 015 0
7	2 DRAIN VALVE	934 300 001 0	22	1 24V-CABLE	449 349 ... 0
6	4 HOSE CLAMP	451 989 ... 2	21	2 EXTENSION CALBE FOR SENSOR	449 723 ... 0
5	2 AIR RESERVOIR	950 ... 0	20	2 EXTENSION CALBE FOR SENSOR	449 723 ... 0
4	1 PARK-RELEASE-EMERG. VALVE (PREV)	452 802 009 0	19	1 POWER-CABLE 7-POL. TO ELECTRONIC	449 347 0.. 0
3	1 LINE FILTER	971 002 9.. 0	18	1 POWER-CABLE 7-POL. W. PLUG SOCKET	449 135 140 0
2	1 DUO-MATIC	432 500 020 0	17	1 POWER-CABLE 7-POL. W. PLUG	449 231 060 0
1	1 CAN-ROUTER-EBB	452 804 012 0	16	1 CAN-ROUTER-EBB	446 122 052 0

WABCO

TRAILER - EBS E
 2-AXLES-TRAILER WITH TRAILER CONTR. VALVE
 AND CAN-ROUTER FOR THE BRAKE CONTROL
 FOR A SECOND TRAILER VEHICLE
 4S/3M, RSS (AIR SUSPENSION)

Copyright WABCO®

Year: 2015-05-04
 Version: BURMESTER
 Date of first issue: 2015-05-04

Doc. Code: 841 601 391 0
 List page: 002
 Sheet: 1/1

Part No.: 841 601 391 0
 Tech. Pass.: 4990
 Replaces for: HMR 00436

EDH-Fu.:
 Part No.:
 Tech. Pass.:
 Replaces for:

* NOT APPLICABLE FOR DISC BRAKE
 ** OPTIONALLY

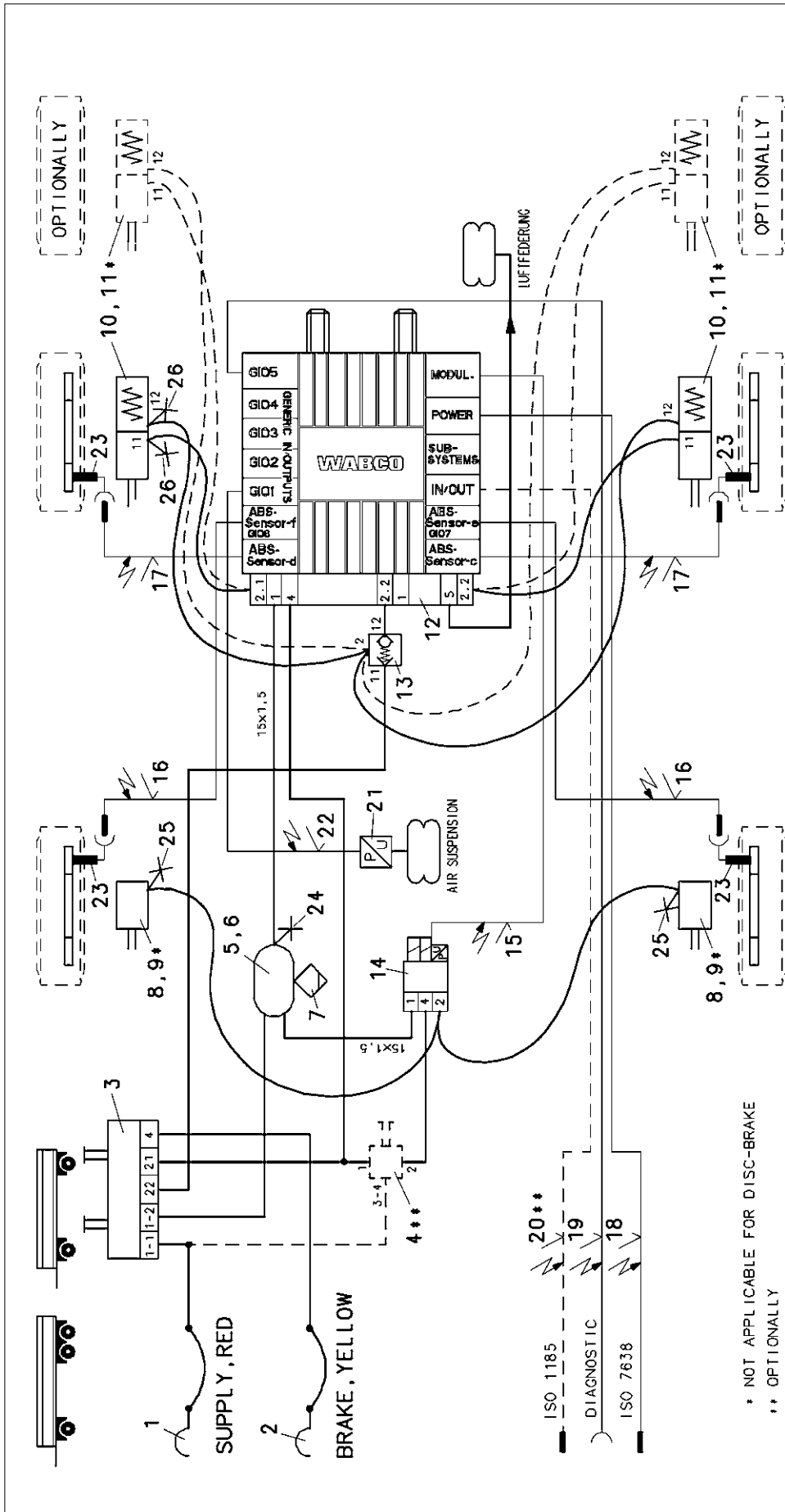

AXLE 3 OPTIONALLY, ALSO USABLE AS 2-AXLES TRAILER

* NOT APPLICABLE FOR DISC-BRAKE
** OPTIONALLY

FIG. NOS.	DENOMINATION	FIG.	NOS.	DENOMINATION	FIG.	NOS.	PRODUCT IDENTIFICATION NO.	DATE
13	1 TWO-WAY-VALVE	434	208	055	025	2	TEST CONNECTION	463 703 036 0
12	1 TRAILER-MODULATOR	480	102	...	025	2	TEST CONNECTION	463 703 120 0
11	2 BEIPACK	423	903	532	224	1	TEST CONNECTION	463 703 ... 0
10	2 TRISTOP BRAKE ACT.	925	023	4	ABS-SENSOR	441 ... 000 0
9	2 KIT	423	222	1	CABLE TO PRESS.SENS.	449 872 ... 0
8	2 BRAKE CHAMBER	934	300	001	020	1	PRESSURE SENSOR	441 040 013 0
7	1 DRAIN VALVE	451	999	...	219	1	24N-CABLE	449 349 000 0
6	2 HOSE CLAMP	950	018	1	DIAGNOSTIC CABLE	449 611 000 0
5	1 AIR RESERVOIR	463	034	005	017	2	SUPPLY(POWER)-CABLE	449 273 000 0
4	1 TRAIL.-RELEASE VALVE	971	002	9...	016	2	EXTENSION CABLE	449 723 000 0
3	1 PARK-RELEASE-EMERG.-VALVE (PREV)	952	201	003	015	1	EXTENSION CABLE	449 723 000 0
2	1 COUPLING HEAD W. INT. LINE FILTER	952	201	004	014	1	CABLE TO EBS-RV	449 429 000 0
1	1 COUPLING HEAD W. INT. LINE FILTER	952	201	004	014	1	EBS-RELAY VALVE	480 207 0... 0
								114843 B 07-10-19
								112957 A 07-04-05
								DATE
								DEN. NO.
								3124
								CODE FOR FUNCTION
								A 3
								SIZE
								171
								T.R.I.
								PRODUCT IDENTIFICATION NO.
								4S/3M
								STANDARDIZATION
								CHECKED
								06-12-04 GROSSK.
								DATE
								06-12-04 AP LITHY
								DRAWN
								SIGNATURE
								DATE
								06-12-04
								CADAM-DRAWING
								COPI-FILE
								NO.

WABCO
TRAILER - EBS-E
 FOR 2-AND 3-AXLES-TRAILER
 4S/3M
 -RSS-

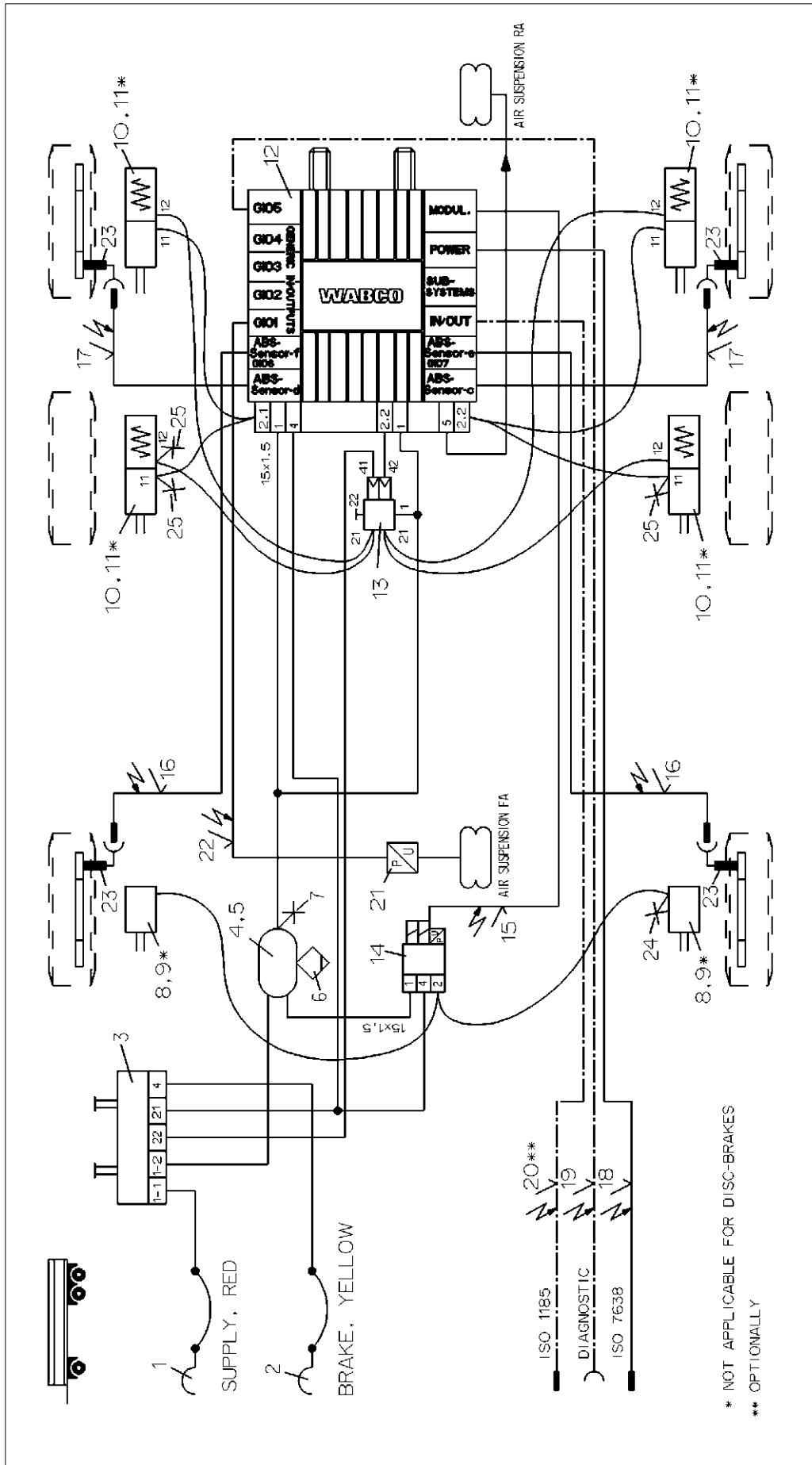

* NOT APPLICABLE FOR DISC-BRAKES
 ** OPTIONALLY

Part No.		Description		Quantity	
13	1	OVERLOAD-PROTECTION-RV	973 011 201 0		
12	1	TRAILER-MODULATOR	480 102 ... 0	25	3
11	4	KIT	423 903 532 2	24	1
10	4	TRISTOP BRAKE ACTUATOR	925 ... 0	23	4
9	2	KIT	423 ... 2	22	1
8	2	BRAKE CHAMBER	423 ... 0	21	1
7	1	TEST CONNECTION	463 703 ... 0	20	1
6	1	DRAIN VALVE	934 300 001 0	19	1
5	2	HOSE CLAMP	451 999 ... 2	18	1
4	1	AIR RESERVOIR	950 ... 0	17	2
3	1	PARK-RELEASE-EMERGENCY VALVE (PREV)	971 002 9... 0	16	2
2	1	COUPLING HEAD W.INT. LINE FILTER	952 201 003 0	15	1
1	1	COUPLING HEAD W.INT. LINE FILTER	952 201 004 0	14	1

Product Identification No.	Denomination	Product Identification No.	Denomination
463 703 036 0	TEST CONNECTION	480 207 0... 0	EBS-RELAY VALVE
463 703 120 0	TEST CONNECTION	449 429 ... 0	CABLE TO EBS-RV
441 ... 0	ABS-SENSOR	449 723 ... 0	EXTENSION CABLE FOR SENSOR
449 812 ... 0	CABLE TO PRESSURE SENSOR	449 811 ... 0	DIAGNOSTIC CABLE
441 040 013 0	PRESSURE SENSOR	449 273 ... 0	SUPPLY (POWER) CABLE
449 349 ... 0	24V-CABLE	449 723 ... 0	EXTENSION CABLE FOR SENSOR
449 611 ... 0	DIAGNOSTIC CABLE	449 429 ... 0	CABLE TO EBS-RV
449 273 ... 0	SUPPLY (POWER) CABLE	480 207 0... 0	EBS-RELAY VALVE

WABCO		TRAILER - EBS E	
FOR 3-AXLES-TRAILER			
4S/3M AIR SUSPENSION WITH RSS			
Doc.No.	841 601 231 0	Rev.	002
Date of first issue:	2008-09-09	Language	EN
Author		Responsible For	
Editor		Part No.	4990

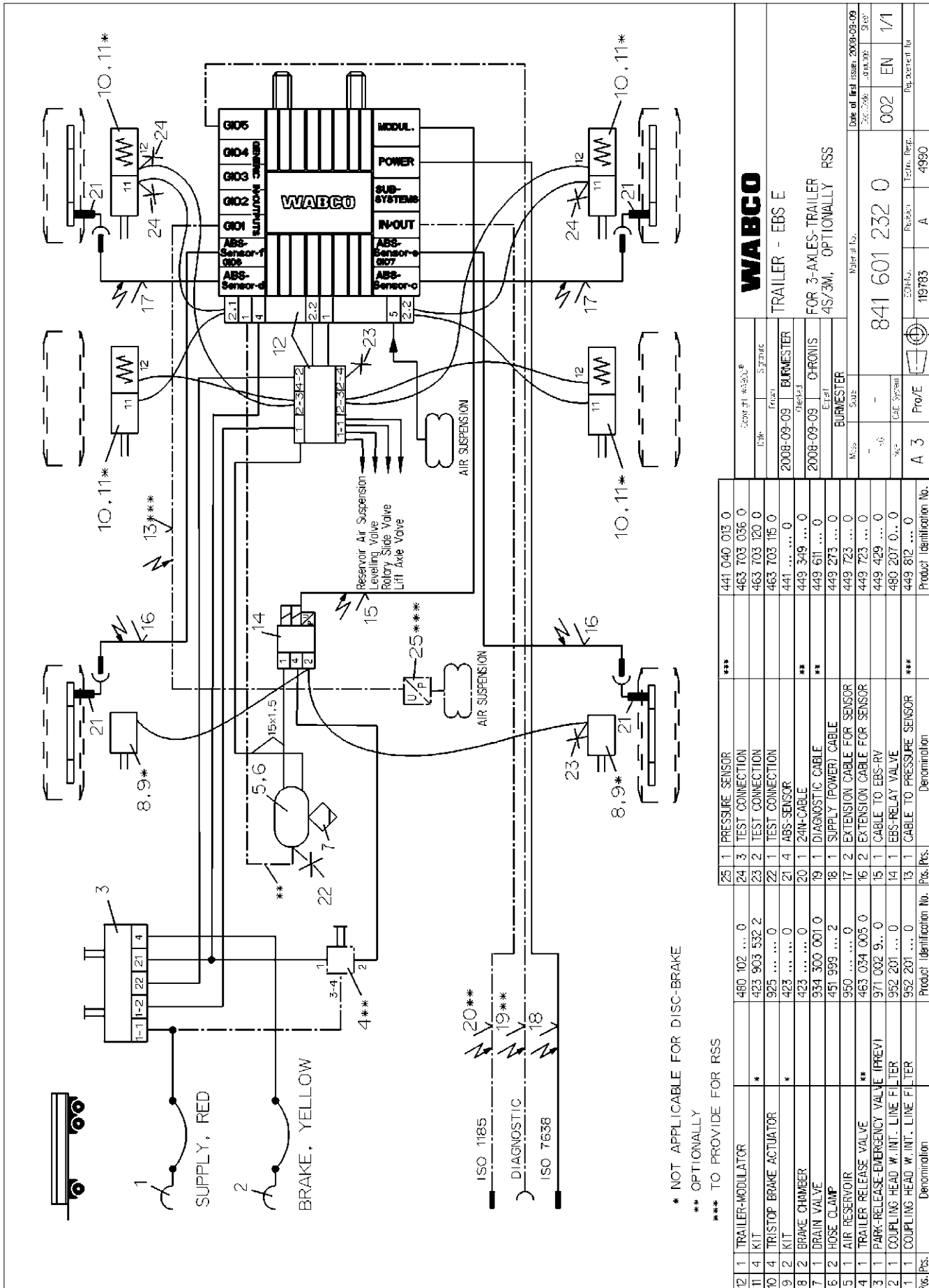

* NOT APPLICABLE FOR DISC-BRAKE
 ** OPTIONALLY
 *** TO PROVIDE FOR RSS

25 1 PRESSURE SENSOR ***		441 040 013 0
24 3 TEST CONNECTION		463 703 036 0
23 2 TEST CONNECTION		463 703 120 0
22 1 TEST CONNECTION		463 703 115 0
21 4 ABS-SENSOR		441 ... 0
20 1 24M-CABLE		449 349 ... 0
19 1 DIAGNOSTIC CABLE		449 611 ... 0
18 1 SUPPLY (POWER) CABLE		449 273 ... 0
17 2 EXTENSION CABLE FOR SENSOR		449 723 ... 0
16 2 EXTENSION CABLE FOR SENSOR		449 723 ... 0
15 1 CABLE TO EBS-RV		449 429 ... 0
14 1 EBS-RELAY VALVE		480 207 0... 0
13 1 CABLE TO PRESSURE SENSOR ***		449 812 ... 0
Product Identification No.	Pos. Pos.	Denomination
	A 3	Pro/E
		E3H-Rev. 119793
		Replaces A 4990
		Request for
	002	EN 1/1
		Doc. Code 000000
		Date of final issue: 2008-09-09

WABCO
 TRAILER - EBS E
 FOR 3-AXLES-TRAILER
 4S/3M, OPTIONALLY RSS

Number of...
 Date of final issue: 2008-09-09
 Doc. Code 000000
 841 601 232 0
 E3H-Rev. 119793
 Replaces A 4990
 Request for

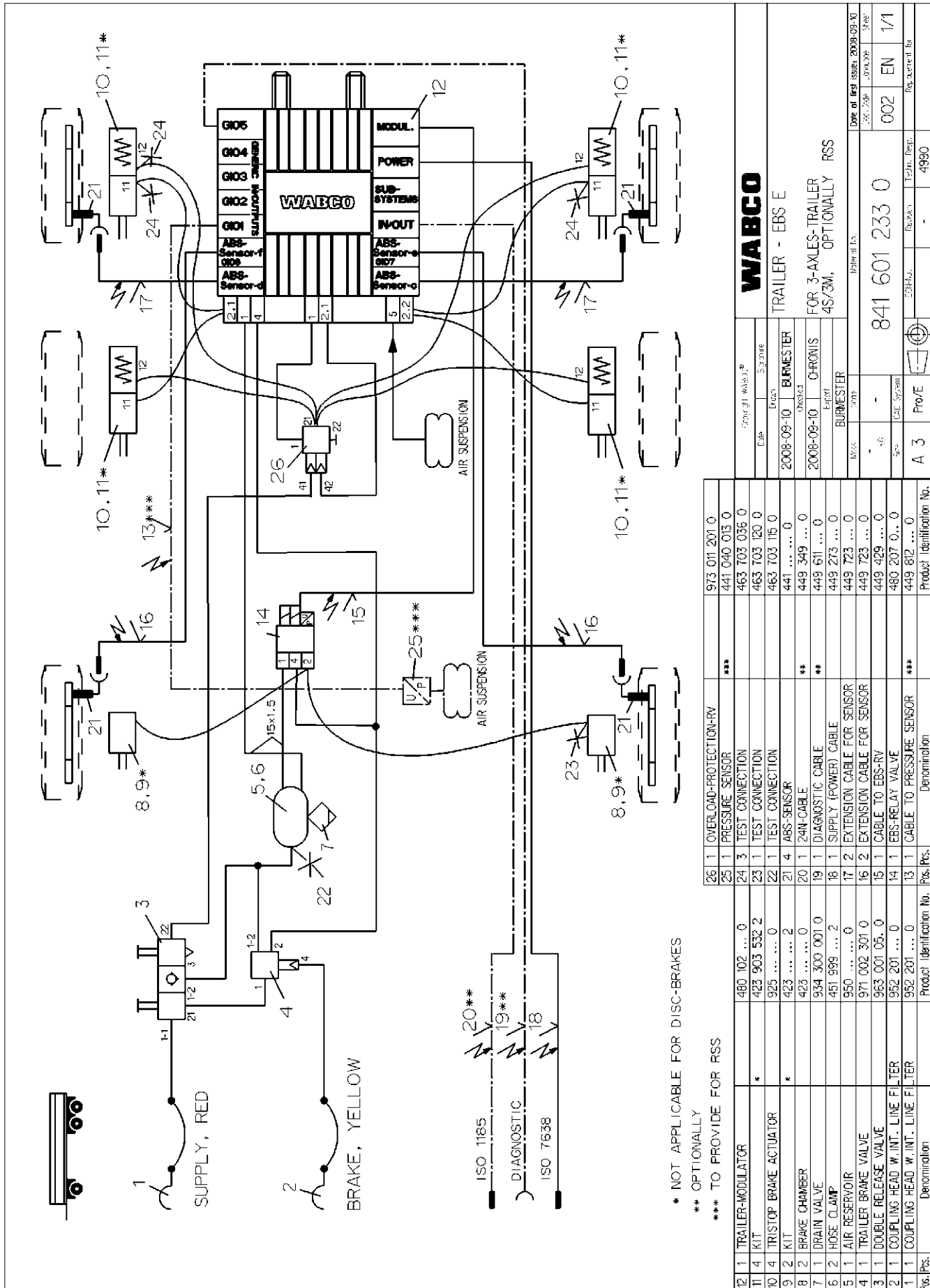

841 601 235 0

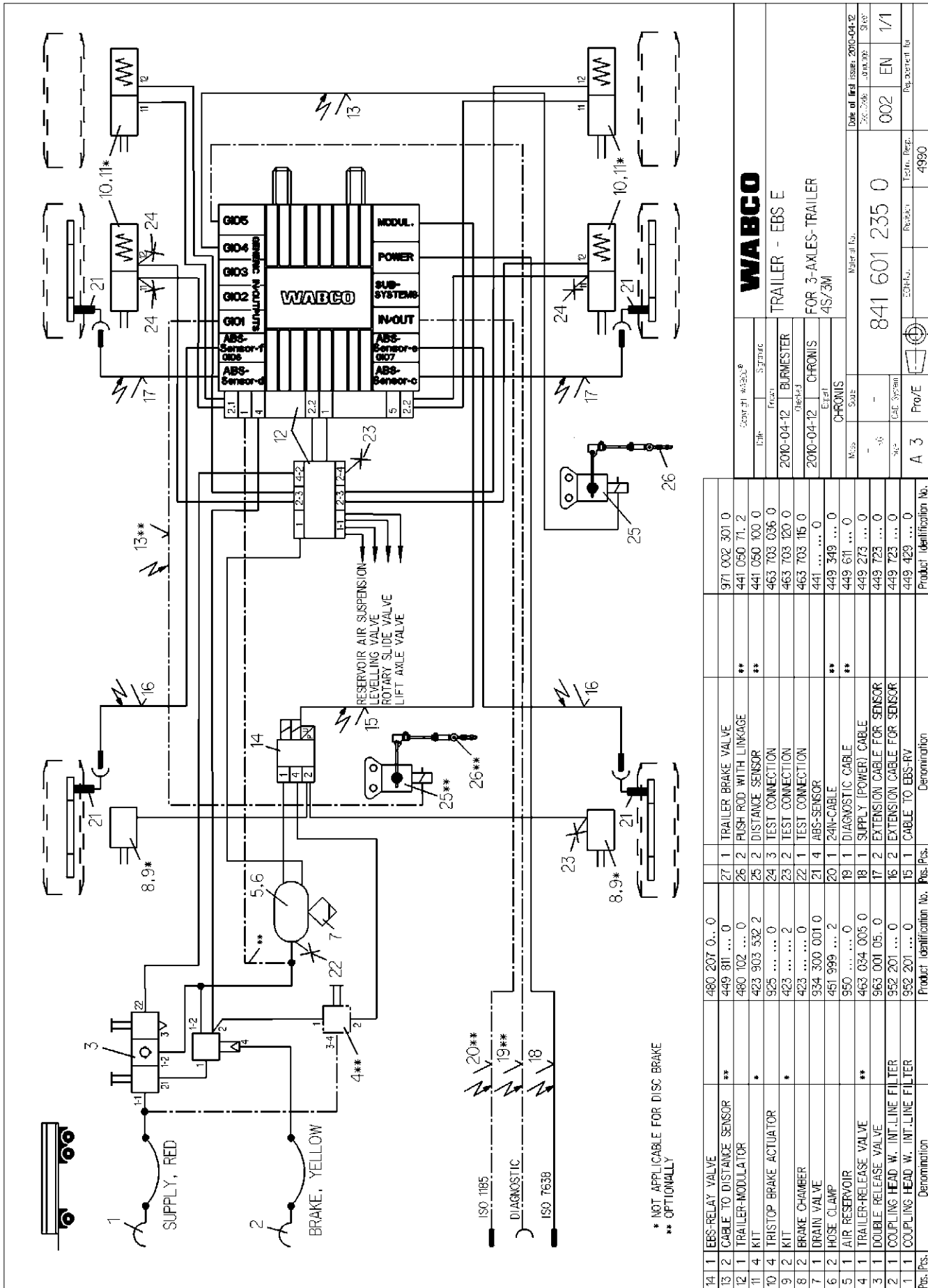

WABCO
TRAILER - EBS E
FOR 3-AXLES-TRAILER
4S/3M

Pos.	Pos.	Product identification No.	Denomination
14	1	480 207 0... 0	EBS-RELAY VALVE
13	2	449 811 ... 0	CABLE TO DISTANCE SENSOR
12	1	480 102 ... 0	TRAILER BRAKE VALVE
11	4	423 903 532 2	TRAILER-MODULATOR
10	4	925 ... 0	TRISTOP BRAKE ACTUATOR
9	2	423 ... 2	KIT
8	1	423 ... 0	BRAKE CHAMBER
7	1	934 300 001 0	DRAIN VALVE
6	2	451 999 ... 2	HOSE CLAMP
5	1	950 ... 0	AIR RESERVOIR
4	1	463 034 005 0	TRAILER-RELEASE VALVE
3	1	563 001 05... 0	DOUBLE RELEASE VALVE
2	1	952 201 ... 0	COUPLING HEAD W. INT-LINE FILTER
1	1	952 201 ... 0	COUPLING HEAD W. INT-LINE FILTER

* NOT APPLICABLE FOR DISC BRAKE
** OPTIONALLY

Date of first issue: 2010-04-12	Req. ref. for
Doc. Code: 444302-B	002 EN 1/1
Doc. Code: 444302-B	Req. ref. for
Doc. Code: 444302-B	4990

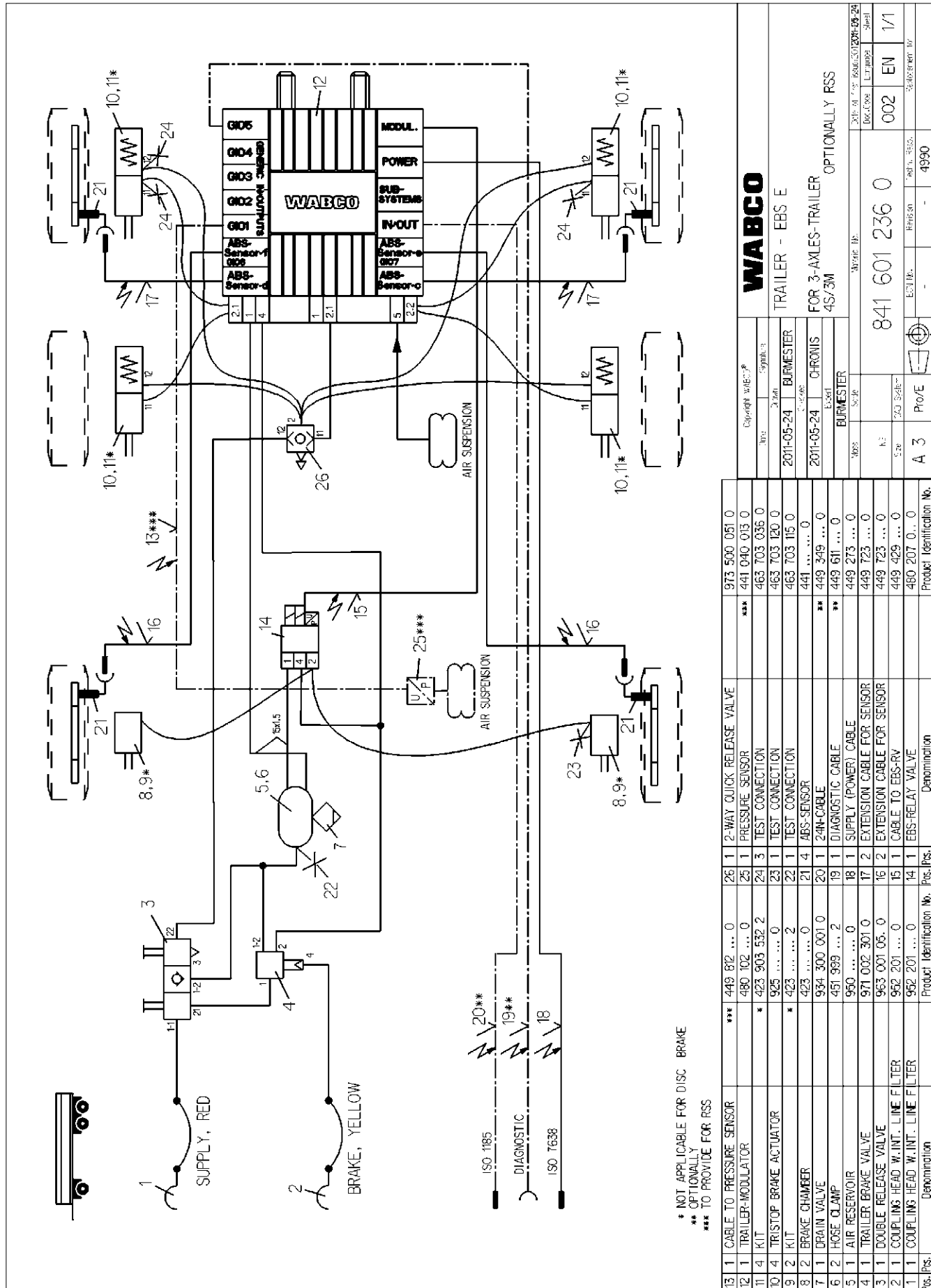

WABCO
 TRAILER - EBS E
 FOR 3-AXLES-TRAILER
 4S/3M
 OPTIONALLY RSS

Doc. Code	Language	Revision
841 601 236 0	EN	1/1

Part No.	Part Name	Part No.
841 601 236 0	TRAILER - EBS E	4990

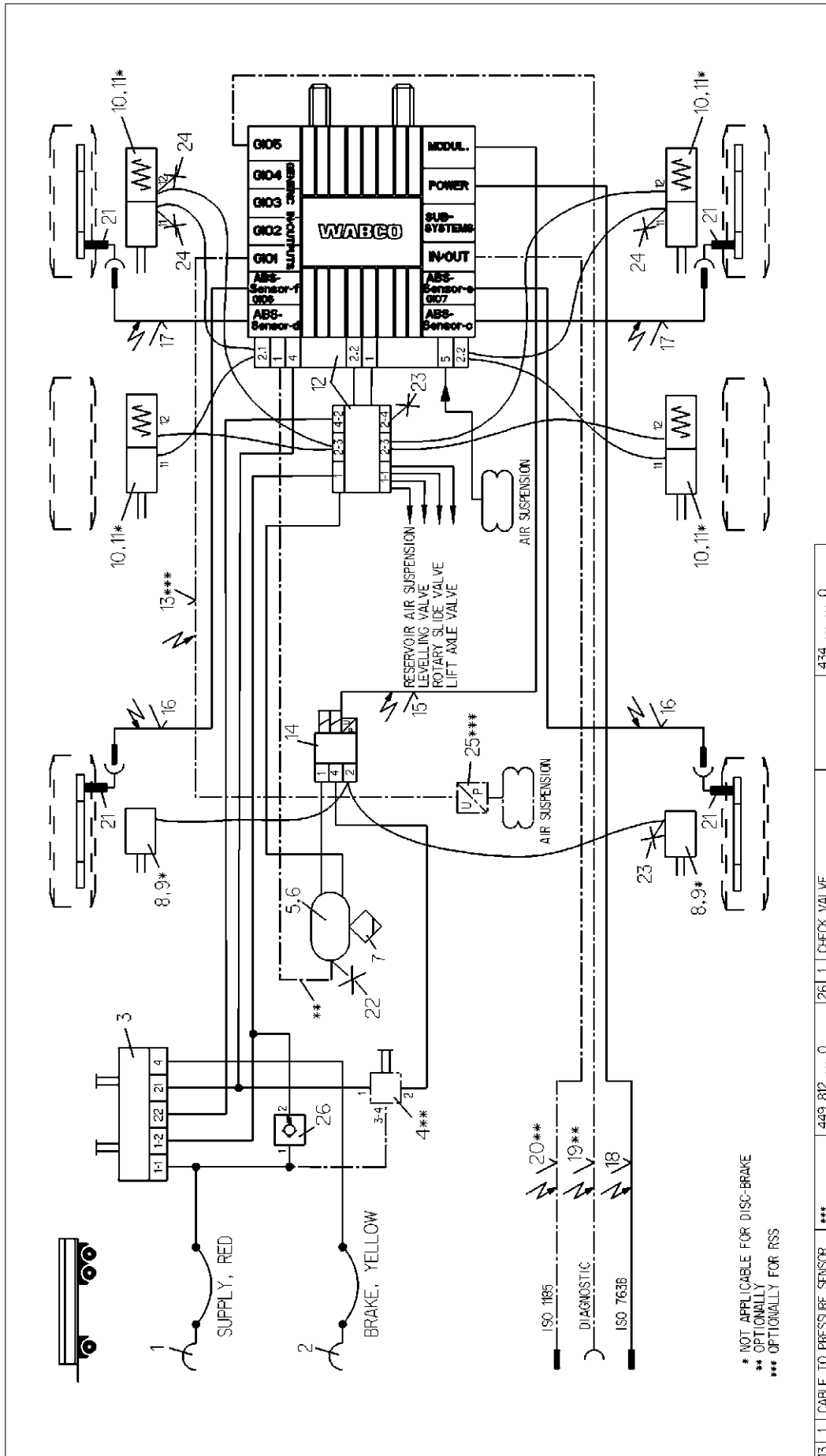

Cable No. WABCO		Part No.		Description	
434 ... 0		441 040 013 0		CHECK VALVE	
441 040 013 0		453 703 036 0		PRESSURE SENSOR	
453 703 036 0		463 703 120 0		TEST CONNECTION	
463 703 120 0		463 703 115 0		TEST CONNECTION	
463 703 115 0		441 ... 0		ABS-SENSOR	
441 ... 0		449 349 ... 0		24IN-CABLE	
449 349 ... 0		449 611 ... 0		DIAGNOSTIC CABLE	
449 611 ... 0		449 273 ... 0		SUPPLY (POWER) CABLE	
449 273 ... 0		449 723 ... 0		EXTENSION CABLE FOR SENSOR	
449 723 ... 0		449 723 ... 0		EXTENSION CABLE FOR SENSOR	
449 723 ... 0		449 429 ... 0		CABLE TO EBS-RV	
449 429 ... 0		480 207 0 ... 0		EBS-RELA-SVENTIL	
480 207 0 ... 0		Product Identification No.		Denomination	
Product Identification No.		Eps.Pcs.		Denomination	

WABCO		TRAILER - EBS E	
FOR 3-AXLES-TRAILER		-RSS-	
4S/3M, WITH CHECK VALVE SUPPLY			
Date of issue: 002-02-20		Sheet	
Cable No. 841 601 237 0		EN 1/1	
Eps.Pcs. 002		Medium. Pcs.	
A 3		Pro/E	
4990			

* NOT APPL CABLE FOR DISC-BRAKE
 ** OPTIONALLY
 *** OPTIONALLY FOR RSS

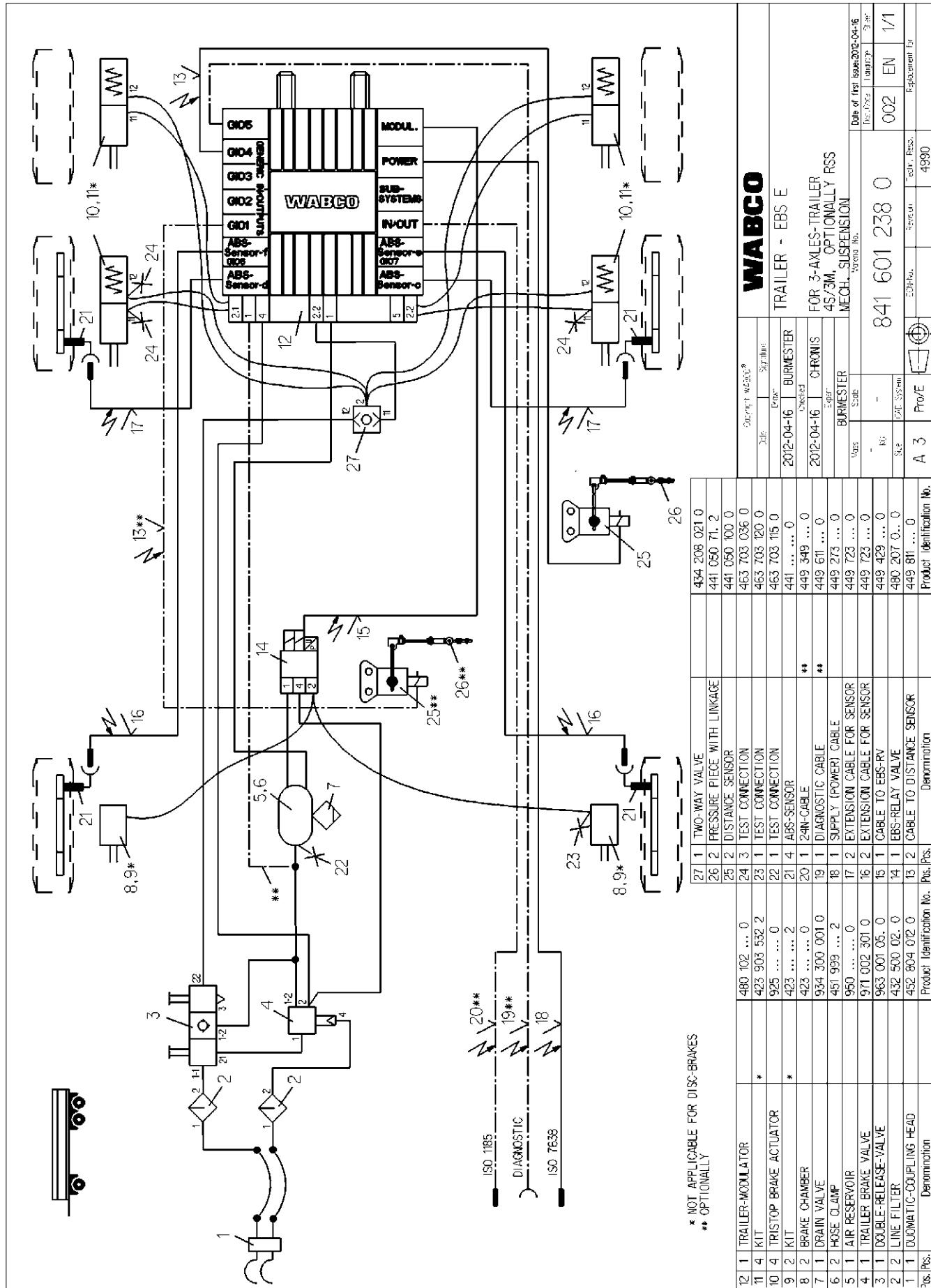

* NOT APPLICABLE FOR DISC-BRAKES
** OPTIONALLY

841 601 360 0

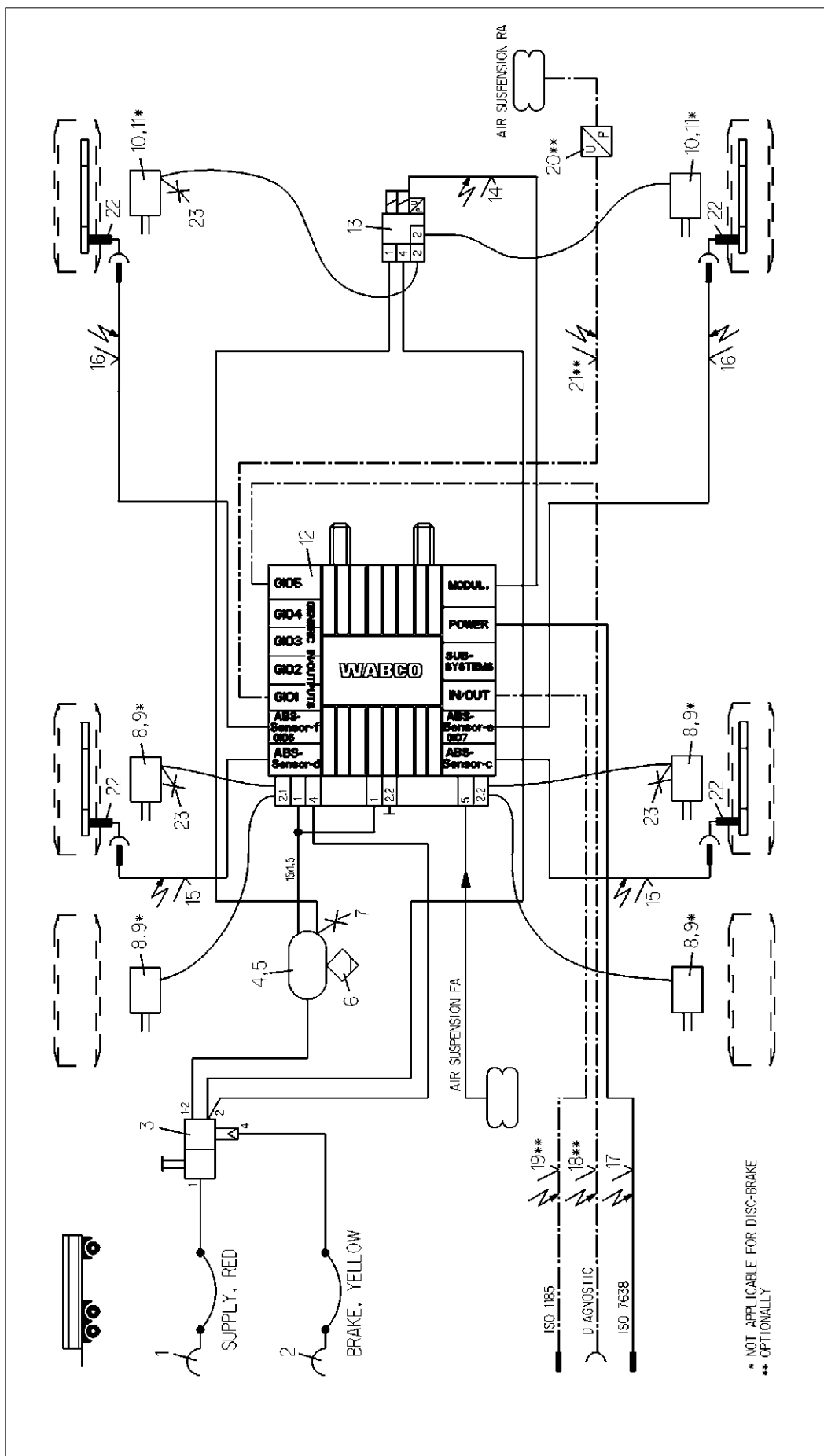

* NOT APPLICABLE FOR DISC-BRAKE
 ** OPTIONALLY

Pos. Pos.	Denomination	Product Identification No.	Pos. Pos.	Denomination	Product Identification No.
12	TRAILER-MODULATOR	480 102 ... 0	24	TEST CONNECTION	463 703 120 0
11	KIT	423 ... 2	23	ABS-SENSOR	441 ... 0
10	BRAKE CHAMBER	423 ... 2	22	CABLE TO PRESSURE SENSOR	449 812 ... 0
9	KIT	423 ... 2	21	PRESSURE SENSOR	441 040 013 0
8	BRAKE CHAMBER	423 ... 2	20	24V-CABLE	449 349 ... 0
7	TEST CONNECTION	463 703 ... 0	19	DIAGNOSTIC CABLE	449 611 ... 0
6	DRAIN VALVE	934 300 001 0	18	SUPPLY (POWER) CABLE	449 273 ... 0
5	HOSE CLAMP	451 999 ... 2	17	EXTENSION CABLE FOR SENSOR	449 723 ... 0
4	AIR RESERVOIR	950 ... 0	16	CABLE TO EBS-RV	449 429 ... 0
3	TRAILER BRAKE VALVE W. RELEASE VALVE	971 002 703 0	15	EBS-RELAY VALVE	480 207 0 ... 0
2	COUPLING HEAD W.INT. LINE FILTER	952 201 ... 0	14		
1	COUPLING HEAD W.INT. LINE FILTER	952 201 ... 0	13		

Year	Model	Object	State	Material No.	Date of first issue: 2015-04-08
2013-01-08	BURMESTER				
2013-01-08	ORONIS				
BURMESTER					
TRAILER - EBS E FOR 3-AXLES-TRAILER 4S/3M OPTIONAL RSS					
841 601 360 0					EN
002					1/1

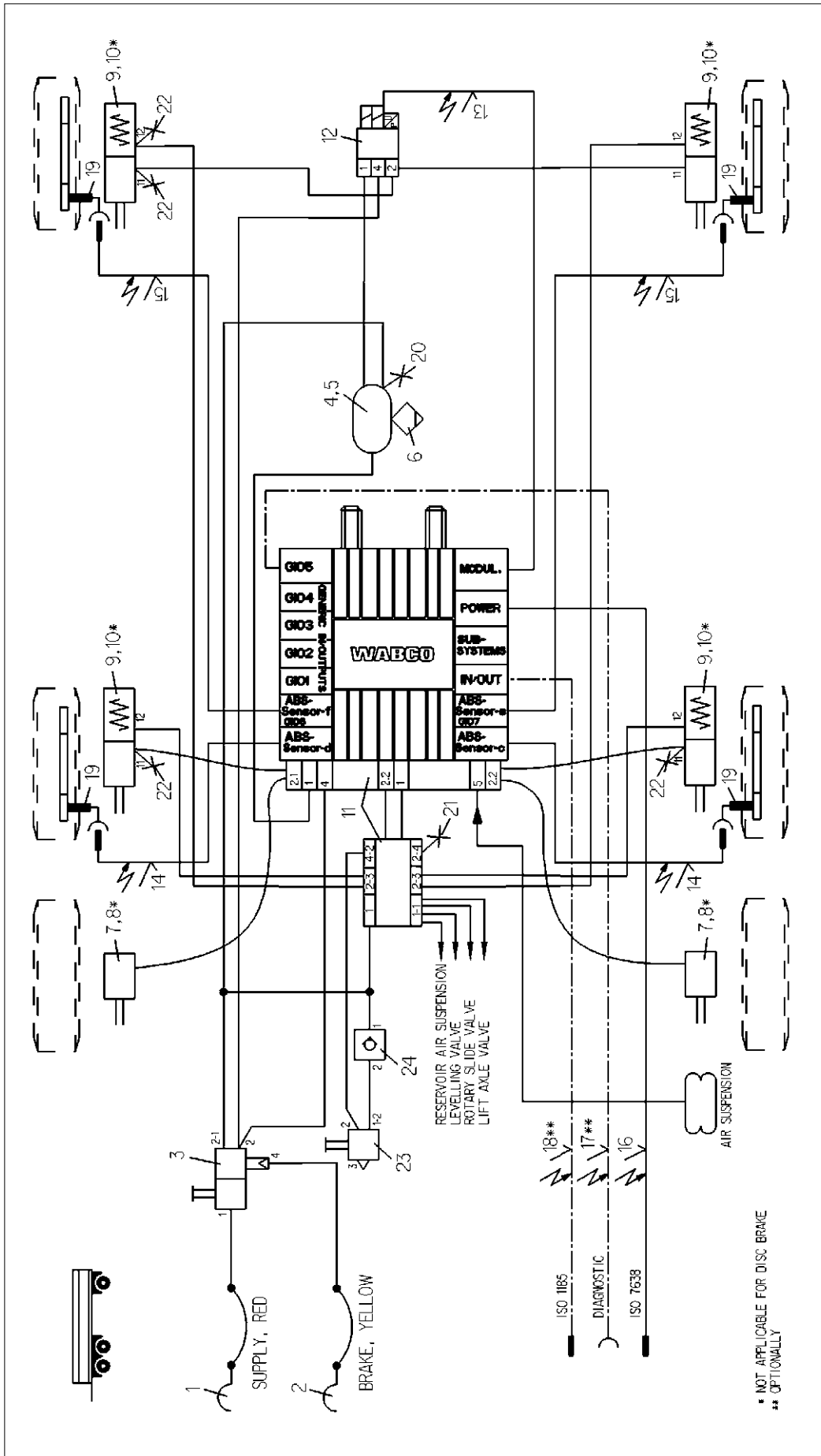

* NOT APPLICABLE FOR DISC BRAKE
 ** OPTIONALLY

EBS-RELAY VALVE		RUECKSCHLAGVENTIL		434 014 000 0	
12	1	480 207 0... 0	24	1	963 006 003 0
11	1	480 102 ... 0	23	1	463 703 120 0
10	4	423 903 532 2	22	4	463 703 120 0
9	4	925 0	21	1	463 703 115 0
8	2	423 2	20	1	441 0
7	2	423 0	19	4	449 349 000 0
6	1	934 300 001 0	18	1	449 611 000 0
5	2	451 999 ... 2	17	1	449 273 000 0
4	1	950 0	16	1	449 273 000 0
3	1	971 002 9... 0	15	2	449 273 000 0
2	1	952 201 003 0	14	2	449 273 000 0
1	1	952 201 004 0	13	1	449 429 000 0
Fig. Pos.	Denomination	Product Identification No.	Pos. Pos.	Denomination	Product Identification No.

WABCO		TRAILER - EBS E		FOR 3-AXLES-TRAILER 4S/3M	
Exemplar-Wabco®	Stichtag	Exemplar-Wabco®	Stichtag	Exemplar-Wabco®	Stichtag
2013-01-23	BURMESTER	2013-01-23	BURMESTER	2013-01-23	CHRONIS
2013-01-23	CHRONIS	2013-01-23	CHRONIS	2013-01-23	CHRONIS
Modul	Scale	Modul	Scale	Modul	Scale
BURMESTER	BURMESTER	BURMESTER	BURMESTER	BURMESTER	BURMESTER
Art. No.	Rev. No.	Art. No.	Rev. No.	Art. No.	Rev. No.
841 601 361 0	002	841 601 361 0	002	841 601 361 0	002
ECU-Mk.	Rev. No.	ECU-Mk.	Rev. No.	ECU-Mk.	Rev. No.
A 3	Pro/E	A 3	Pro/E	A 3	Pro/E
4990	4990	4990	4990	4990	4990

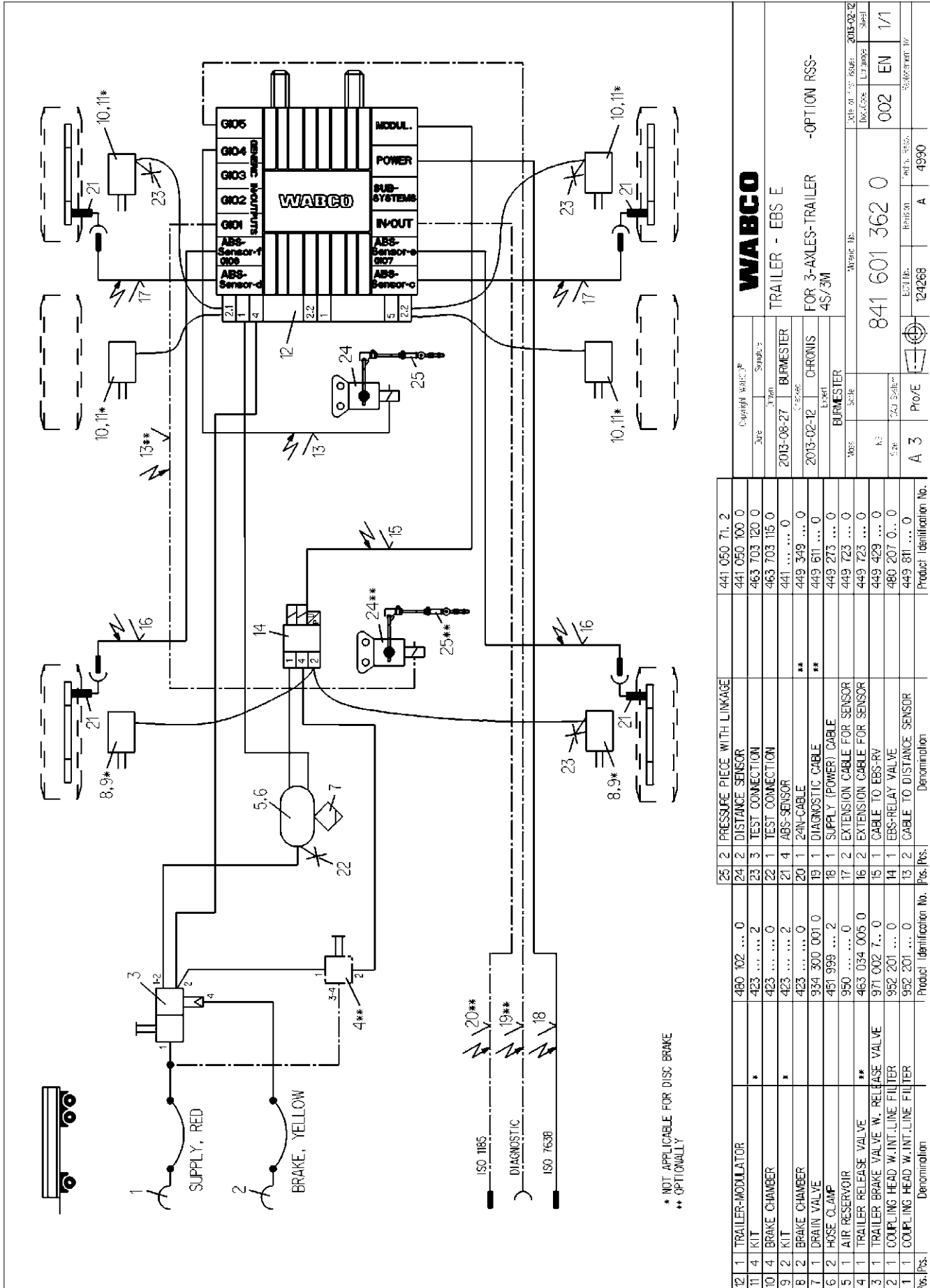

* NOT APPLICABLE FOR DISC BRAKE
 ** OPTIONALLY

12	1	TRAILER-MODULATOR	480 102 ... 0	441 050 71. 2	Product Identification No.
11	4	KIT	423 2	441 050 700 0	
10	4	BRAKE CHAMBER	423 0	463 703 120 0	
9	2	BRAKE CHAMBER	423 2	463 703 115 0	
8	2	DRAIN VALVE	423 0	441 0	
7	1	HOSE CLAMP	934 300 001 0	449 349 ... 0	
6	2	AIR RESERVOIR	451 999 ... 2	449 611 ... 0	
5	1	TRAILER RELEASE VALVE	950 0	449 273 ... 0	
4	1	TRAILER BRAKE VALVE W. RELEASE VALVE	463 034 005 0	449 723 ... 0	
3	1	COUPLING HEAD W.INT.LINE FILTER	971 002 7... 0	449 723 ... 0	
2	1	COUPLING HEAD W.INT.LINE FILTER	952 201 ... 0	449 429 ... 0	
1	1	COUPLING HEAD W.INT.LINE FILTER	952 201 ... 0	480 207 ... 0	
Pos./Pcs.		Denomination	Product Identification No.	Pos./Pcs.	Denomination
<p>WABCO</p> <p>TRAILER - EBS E</p> <p>FOR 3-AXLES-TRAILER -OPTION RSS-</p> <p>4S/3M</p>					
<p>2013-08-27 BURMESTER</p> <p>2013-02-12 CHRONIS</p> <p>BURMESTER</p>					
<p>Scale: 1:1</p> <p>Part No.: 841 601 362 0</p> <p>Revision: A</p> <p>Pro/E</p> <p>124268</p> <p>4990</p>					
<p>2013-02-12</p> <p>Doc. Code: 8416013620</p> <p>Issue: 002</p> <p>EN</p> <p>1/1</p>					

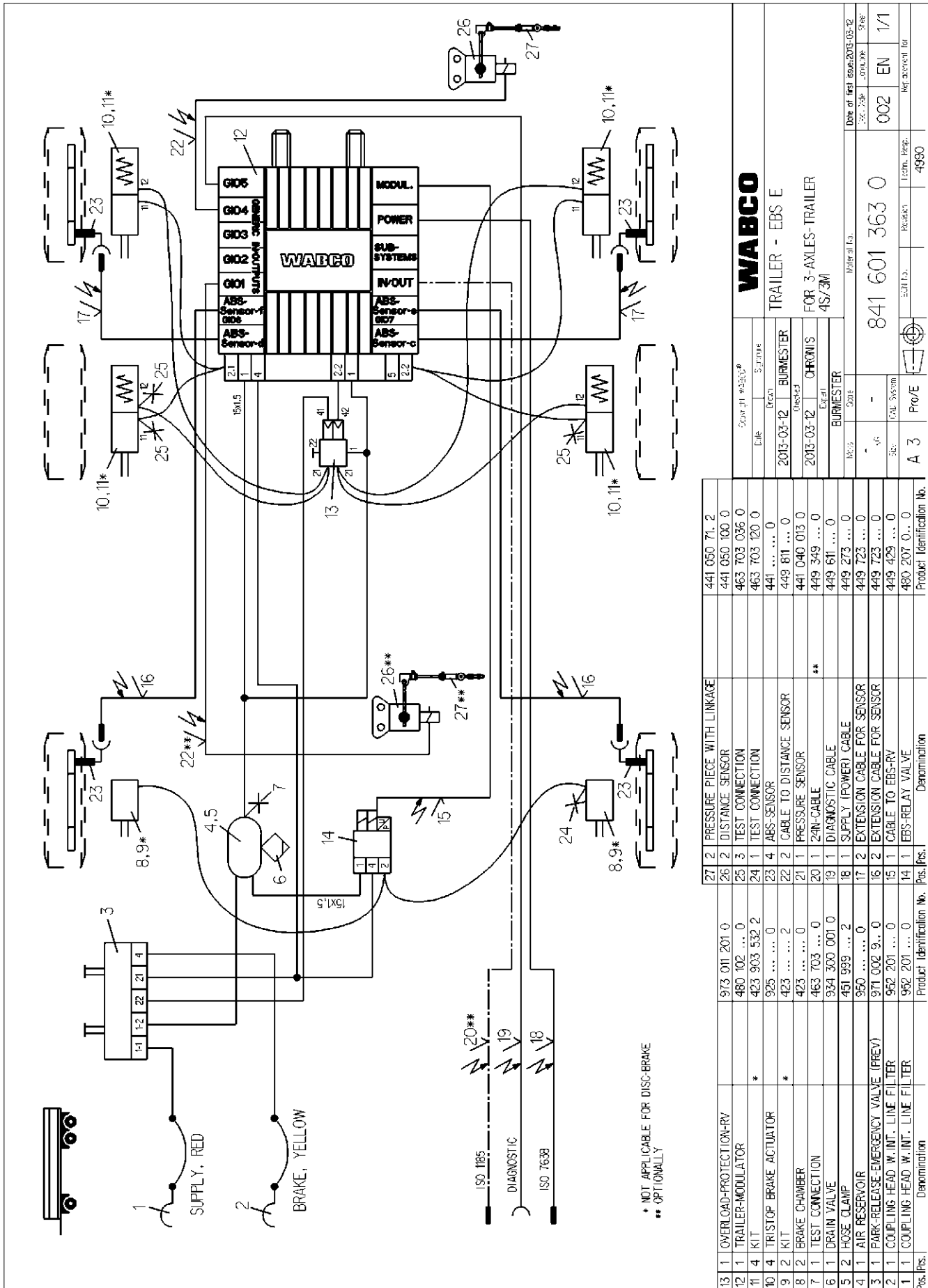

* NOT APPLICABLE FOR DISC BRAKE
 ** OPTIONAL

Pos. / Pos.	Description	Product Identification No.	Pos. / Pos.	Description	Product Identification No.	
13	OVERLOAD-PROTECTION-RV	973 011 201 0	27	2	PRESSURE PIECE WITH LINKAGE	441 050 71- 2
12	TRAILER-MODULATOR	480 102 ... 0	26	2	DISTANCE SENSOR	441 050 100 0
11	4 KIT	423 903 532 2	25	3	TEST CONNECTION	463 703 036 0
10	4 TRISTOP BRAKE ACTUATOR	925 0	24	1	TEST CONNECTION	463 703 120 0
9	2 KIT	423 2	23	4	ABS-SENSOR	441 0
8	2 BRAKE CHAMBER	423 0	22	2	CABLE TO DISTANCE SENSOR	449 811 ... 0
7	1 TEST CONNECTION	463 703 ... 0	21	1	PRESSURE SENSOR	441 040 013 0
6	1 DRAIN VALVE	924 300 001 0	20	1	24N-CABLE	449 349 ... 0
5	2 HOSE CLAMP	451 999 ... 2	19	1	DIAGNOSTIC CABLE	449 611 ... 0
4	1 AIR RESERVOIR	950 0	18	1	SUPPLY (POWER) CABLE	449 723 ... 0
3	1 PARK-RELEASE-EMERGENCY VALVE (PREV)	971 002 9... 0	17	2	EXTENSION CABLE FOR SENSOR	449 723 ... 0
2	1 COUPLING HEAD W.INT. LINE FILTER	952 201 ... 0	16	2	EXTENSION CABLE FOR SENSOR	449 429 ... 0
1	1 COUPLING HEAD W.INT. LINE FILTER	952 201 ... 0	15	1	CABLE TO EBS-RV	480 207 ... 0
			14	1	EBS-RELAY VALVE	

WABCO		Part no.:		Date of first issue: 2013-03-12	
File	Symbol	Part no.	Revision	Form. Resp.	Prep.
2013-03-12	BURMESTER	841 601 363 0		002	EN 1/1
2013-03-12	CHROMIS				
TRAILER - EBS E		841 601 363 0			
FOR 3-AXLES-TRAILER					
4S/3M					
BURMESTER					
		A 3		Pro/E	4990

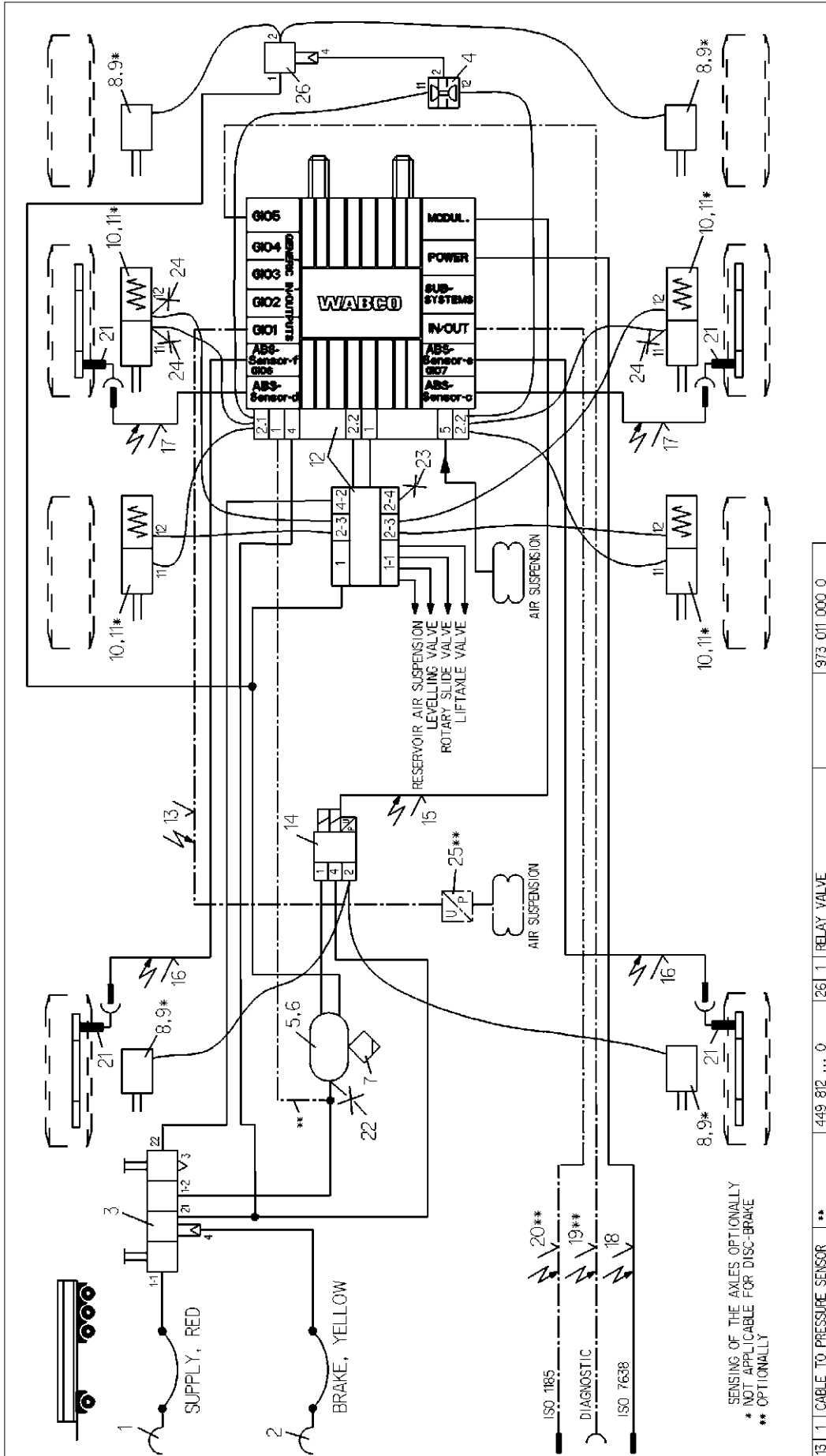

Cuts		Symbols	
2012-09-27	BURMESTER	2012-08-27	CHRONIS
Date of final issue: 2012-08-27		Date of final issue: 2012-08-27	
Job No. 000.000		Job No. 000.000	
Shed		Shed	
WABCO			
TRAILER - EBE E			
FOR 4-AXLES-TRAILER			
4S/3M NLLA SELECT LOW			
WABCO No. 841 601 198 0			
Rev. No.		Rev. No.	
002		EN	
1/1		Represent Int.	
A 3 Pro/E			
Product Identification No. 973 011 000 0			
13	1	CABLE TO PRESSURE SENSOR	**
12	1	TRAILER-MODULATOR	**
11	4	KIT	*
10	4	TRISTOP BRAKE ACTUATOR	*
9	4	KIT	*
8	4	BRAKE CHAMBER	*
7	1	DRAIN VALVE	*
6	2	HOSE CLAMP	*
5	1	RESERVOIR	*
4	1	DOUBLE SHUT-OFF VALVE	*
3	1	PARK-RELEASE-EMERG.VALVE (PREV)	*
2	1	COUPLING HEAD W. INT. LINE FILTER	*
1	1	COUPLING HEAD W. INT. LINE FILTER	*
Rev. Pos.	Denomination		Product Identification No. / Pos. Pos.
	Denomination		Product Identification No. / Pos. Pos.

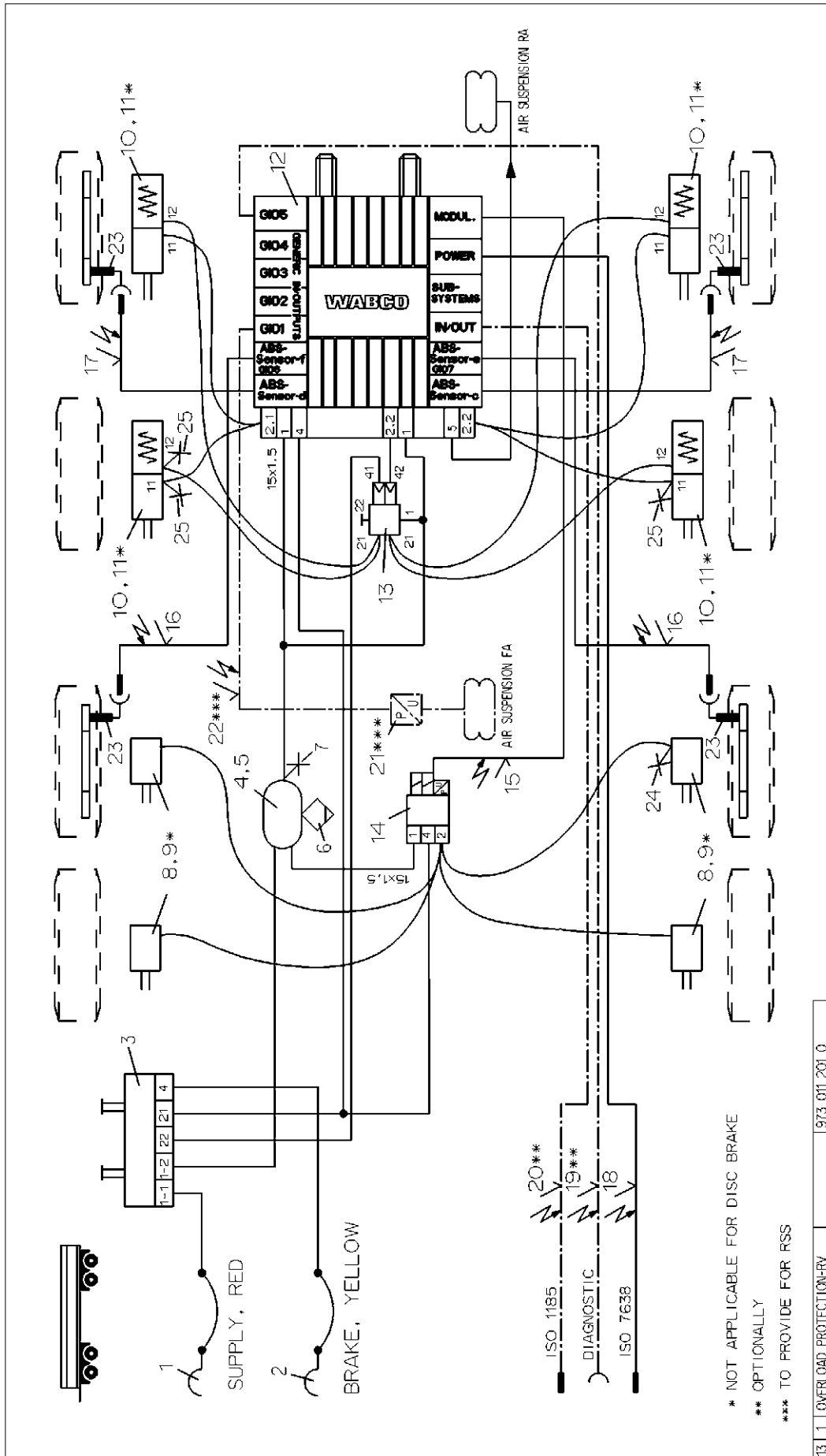

* NOT APPLICABLE FOR DISC BRAKE
** OPTIONALLY
*** TO PROVIDE FOR RSS

Product Identification No.		Denomination		Product Identification No.		Denomination	
Pos.	Pos.	Pos.	Pos.	Pos.	Pos.	Pos.	Pos.
13	1 OVERLOAD PROTECTION-RV	973 011 201 0		25	3 TEST CONNECTION	463 703 036 0	
12	1 TRAILER-MODULATOR	480 102 ... 0		24	1 TEST CONNECTION	463 703 120 0	
11	4 KIT	423 903 532 2	*	23	4 ABS-SENSOR	441 0	
10	4 TRISTOP BRAKE ACTUATOR	925 0		22	1 CABLE TO PRESSURE SENSOR	449 812 ... 0	
9	4 KIT	423 2	*	21	1 PRESSURE SENSOR	441 040 013 0	
8	4 BRAKE CHAMBER	423 0		20	1 2-IN-CABLE	449 349 ... 0	
7	1 TEST CONNECTION	463 703 ... 0		19	1 DIAGNOSTIC CABLE	449 611 ... 0	
6	1 DRAIN VALVE	934 300 001 0		18	1 SUPPLY (POWER) CABLE	449 273 ... 0	
5	1 HOSE CLAMP	451 999 ... 2		17	2 EXTENSION CABLE FOR SENSOR	449 723 ... 0	
4	1 RESERVOIR	950 0		16	2 EXTENSION CABLE FOR SENSOR	449 723 ... 0	
3	1 PARK-RELEASE-EMERG. VALVE (PREV.)	971 002 9... 0		15	1 CABLE TO EBS-RV	449 429 ... 0	
2	1 COUPLING HEAD W. INT. LINE FILTER	952 201 ... 0		14	1 EBS-RELAY VALVE	480 207 0... 0	
1	1 COUPLING HEAD W. INT. LINE FILTER	952 201 ... 0					

WABCO		CONTR. WABCO®	
TRAILER - EBS E		Type	3-Frame
FOR 4-AXLES-TRAILER		Part No.	2010-11-09 BURMESTER
4S/3N W.V. RSS		Original	2010-11-09 CHRONIS
		Export	BURMESTER
		Subst.	
		Mass	
		Material No.	
		Date of first issue	2010-11-09
		Doc. Code	400000
		State	
		002	EN
		1/1	
		Request for	
		4990	

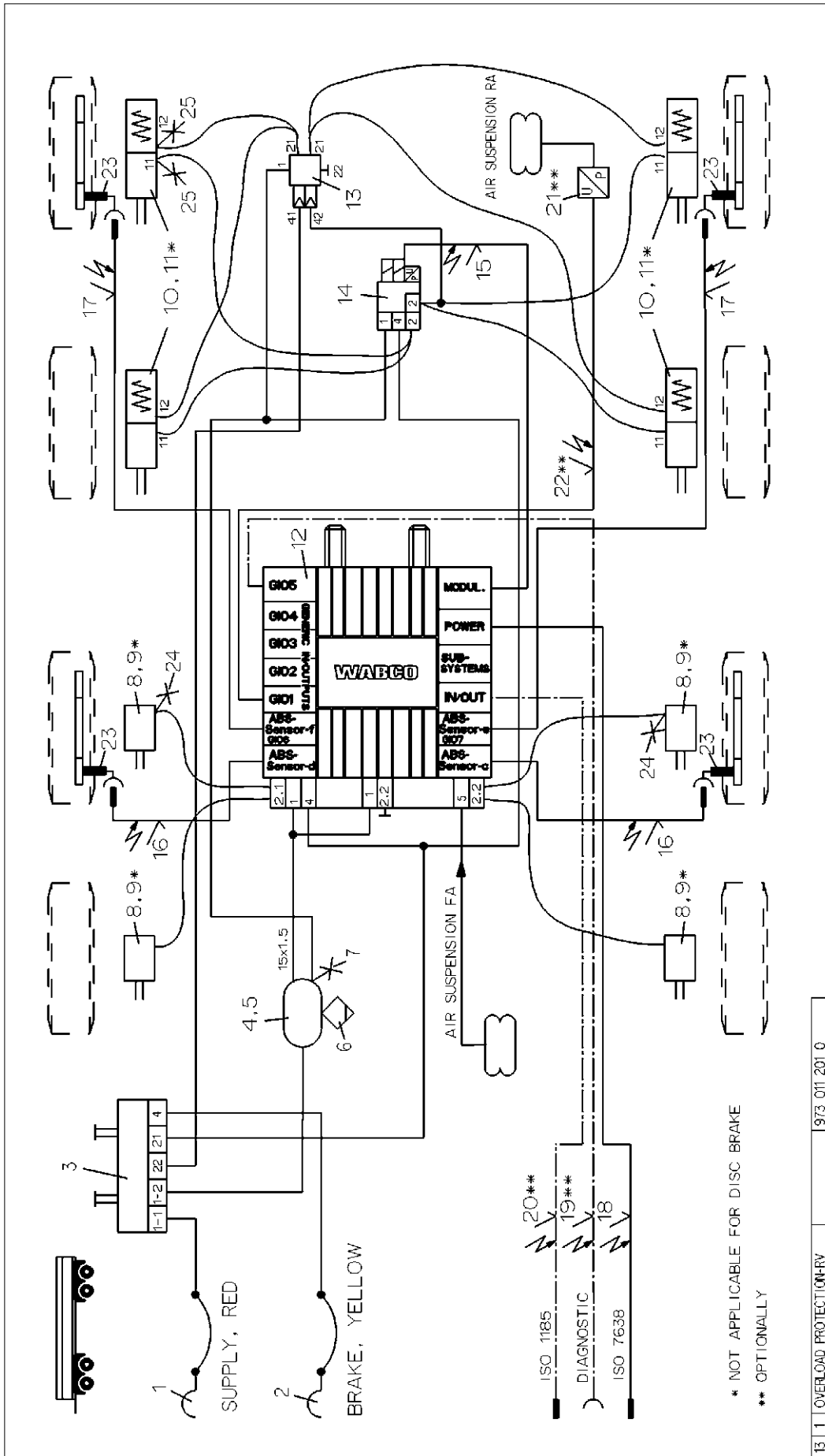

* NOT APPLICABLE FOR DISC BRAKE
 ** OPTIONALLY

Pos. Pcs.	Denomination	Product Identification No.	Pos. Pcs.	Denomination	Product Identification No.
13 1	OVERLOAD PROTECTION-RV	973 011 201 0	25 2	TEST CONNECTION	463 703 036 0
12 1	TRAILER-MODULATOR	480 102 ... 0	24 2	TEST CONNECTION	463 703 120 0
11 4	KIT	423 903 532 2	23 4	ABS-SENSOR	441 0
10 4	TRISTOP BRAKE ACTUATOR	925 0	22 1	CABLE TO PRESSURE SENSOR	449 812 ... 0
9 4	KIT	423 2	21 1	PRESSURE SENSOR	441 040 013 0
8 4	BRAKE CHAMBER	423 0	20 1	24W-CABLE	449 349 ... 0
7 1	TEST CONNECTION	463 703 ... 0	19 1	DIAGNOSTIC CABLE	449 611 ... 0
6 1	DRAIN VALVE	934 300 001 0	18 1	SUPPLY (POWER) CABLE	449 273 ... 0
5 2	HOSE CLAMP	451 999 ... 2	17 2	EXTENSION CABLE FOR SENSOR	449 723 ... 0
4 1	RESERVOIR	950 0	16 2	EXTENSION CABLE FOR SENSOR	449 723 ... 0
3 1	PARK-RELEASE-EMERG. VALVE (PREV)	971 002 9... 0	15 1	CABLE TO EBS-RV	449 429 ... 0
2 1	COUPLING HEAD W. INT. LINE FILTER	952 201 ... 0	14 1	EBS-RELAY VALVE	480 207 0... 0
1 1	COUPLING HEAD W. INT. LINE FILTER	952 201 ... 0			

Date		Signature
2010-11-09	BURMESTER	
Checked		
2010-11-09	CHRONIS	
Typed		
	BURMESTER	
Date of first issue: 2010-11-09		
US-Logo	Language	9-Pos.
841 601 241 0		Replacement for
002 EN 1/1		
E30-Haus		Year, Reso.
A 3 Pro/E		4990

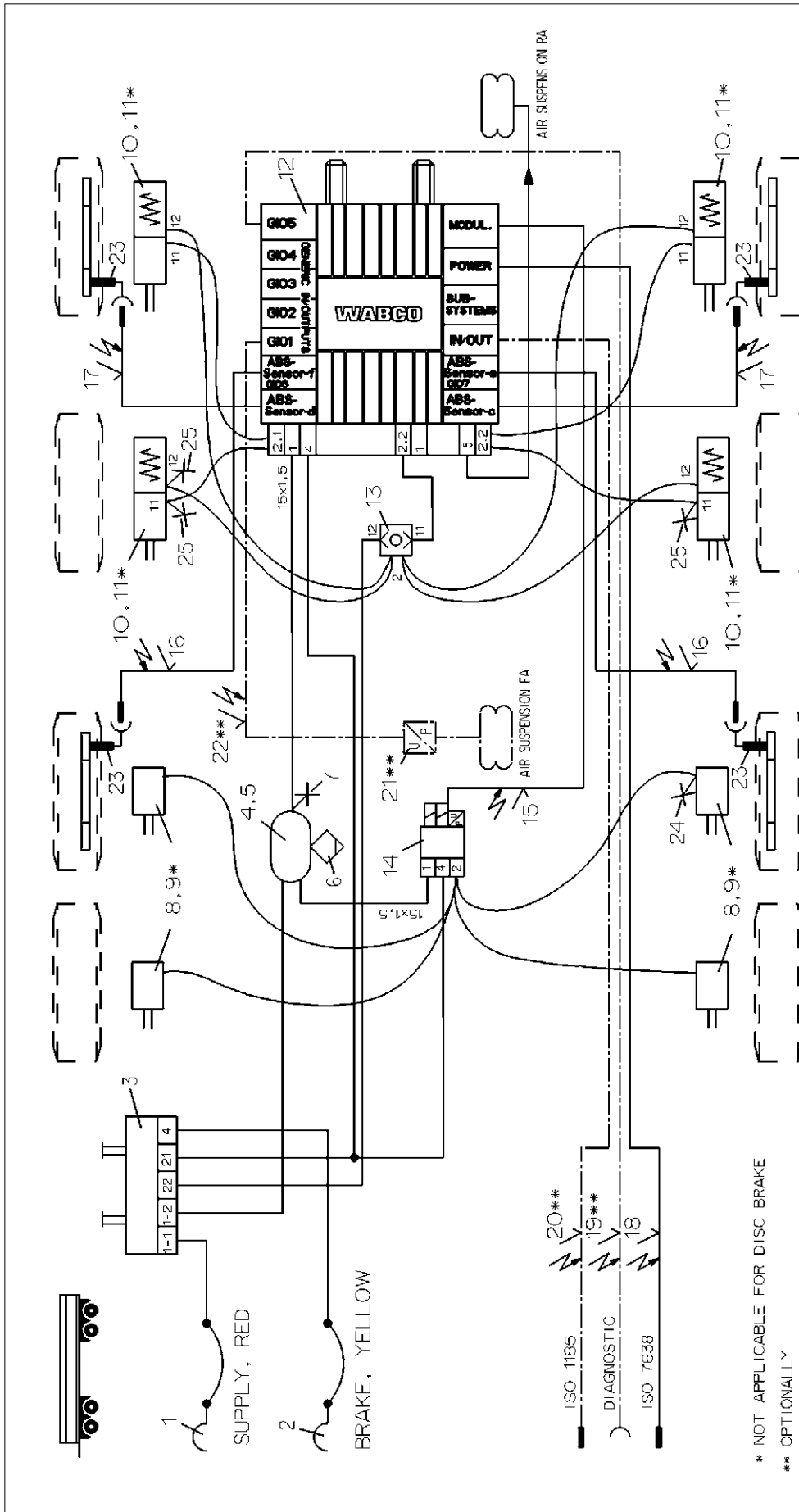

* NOT APPLICABLE FOR DISC BRAKE
 ** OPTIONALLY

Part No.		Description		Product Identification No.		Pos./Pcs.	
13	1	973 500 051 0	QUICK RELEASE VALVE				
12	1	480 102 ... 0	TRAILER-MODULATOR	463 703 036 0			
11	4	423 903 532 2	KIT	463 703 120 0			
10	4	925 0	TRISTOP BRAKE ACTUATOR	441 0			
9	4	423 2	KIT	449 812 ... 0			
8	4	423 0	BRAKE CHAMBER	441 040 013 0			
7	1	463 703 ... 0	TEST CONNECTION	449 349 ... 0			
6	1	934 300 001 0	DRAIN VALVE	449 611 ... 0			
5	2	451 999 ... 2	HOSE CLAMP	449 273 ... 0			
4	1	950 0	RESERVOIR	449 723 ... 0			
3	1	971 002 9... 0	PARK-RELEASE-EMERG. VALVE (PREV)	449 723 ... 0			
2	1	952 201 ... 0	COUPLING HEAD W. INT. LINE FILTER	449 429 ... 0			
1	1	952 201 ... 0	COUPLING HEAD W. INT. LINE FILTER	480 207 0... 0			

Date of first issue: 2010-11-09		Date of next issue: 2010-11-09	
Doc. No.	Doc. Name	Doc. No.	Doc. Name
2010-11-09	BURMESTER	2010-11-09	CHRONIS
Checked		Checked	
Report		Report	
Date		Date	
2010		2010	
Part No.		Part No.	
841 601 242 0		841 601 242 0	
Title		Title	
TRAILER - EBS E		TRAILER - EBS E	
For		For	
FOR 4-AXLES-TRAILER		FOR 4-AXLES-TRAILER	
4S/3M WW, RSS		4S/3M WW, RSS	
Author		Author	
EHS/...		EHS/...	
Part No.		Part No.	
4990		4990	

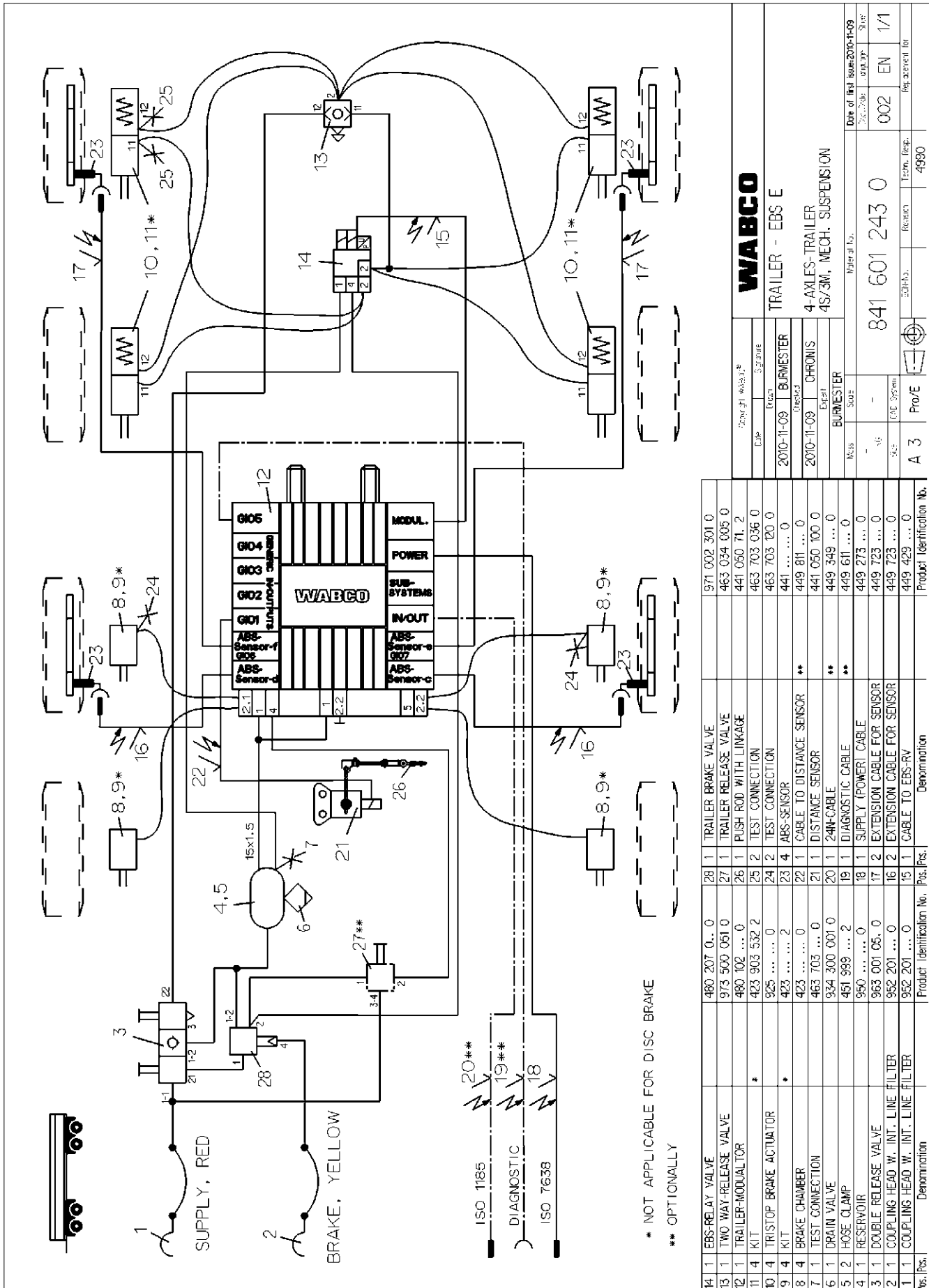

* NOT APPLICABLE FOR DISC BRAKE

** OPTIONALLY

14	1	EBS-RELAY VALVE	480 20T 0... 0	28	1	TRAILER BRAKE VALVE	971 002 301 0
13	1	TWO WAY-RELEASE VALVE	973 500 061 0	27	1	TRAILER RELEASE VALVE	463 034 005 0
12	1	TRAILER-MODULATOR	480 702 ... 0	26	1	PUSH ROD WITH LINKAGE	441 050 71... 2
11	4	KIT	423 903 532 2	25	2	TEST CONNECTION	463 703 036 0
10	4	TRISTOP BRAKE ACTUATOR	925 0	24	2	TEST CONNECTION	463 703 020 0
9	4	KIT	423 0	23	4	ABS-SENSOR	441 0
8	4	BRAKE CHAMBER	423 0	22	1	CABLE TO DISTANCE SENSOR	449 811 ... 0
7	1	TEST CONNECTION	463 703 ... 0	21	1	DISTANCE SENSOR	441 050 600 0
6	1	DRAIN VALVE	934 300 001 0	20	1	24H-CABLE	449 349 ... 0
5	2	HOSE CLAMP	451 999 ... 2	19	1	DIAGNOSTIC CABLE	449 611 ... 0
4	1	RESERVOIR	950 0	18	1	SUPPLY (POWER) CABLE	449 273 ... 0
3	1	DOUBLE RELEASE VALVE	963 001 05... 0	17	2	EXTENSION CABLE FOR SENSOR	449 723 ... 0
2	1	COUPLING HEAD W. INT. LINE FILTER	952 201 ... 0	16	2	EXTENSION CABLE FOR SENSOR	449 723 ... 0
1	1	COUPLING HEAD W. INT. LINE FILTER	952 201 ... 0	15	1	CABLE TO EBS-RV	449 429 ... 0
Pos. (Pos.)		Denomination	Product Identification No.	Pos. (Pos.)		Denomination	Product Identification No.

WABCO

TRAILER - EBS E

4-AXLES-TRAILER
4S/3M, MECH. SUSPENSION

841 601 243 0

Part No.	841 601 243 0
Doc. type	EN
Rev.	002
Date of first issue	2010-11-09
Doc. type	EN
Rev.	1/1
Doc. type	EN
Rev.	002
Date of first issue	2010-11-09

841 601 245 0

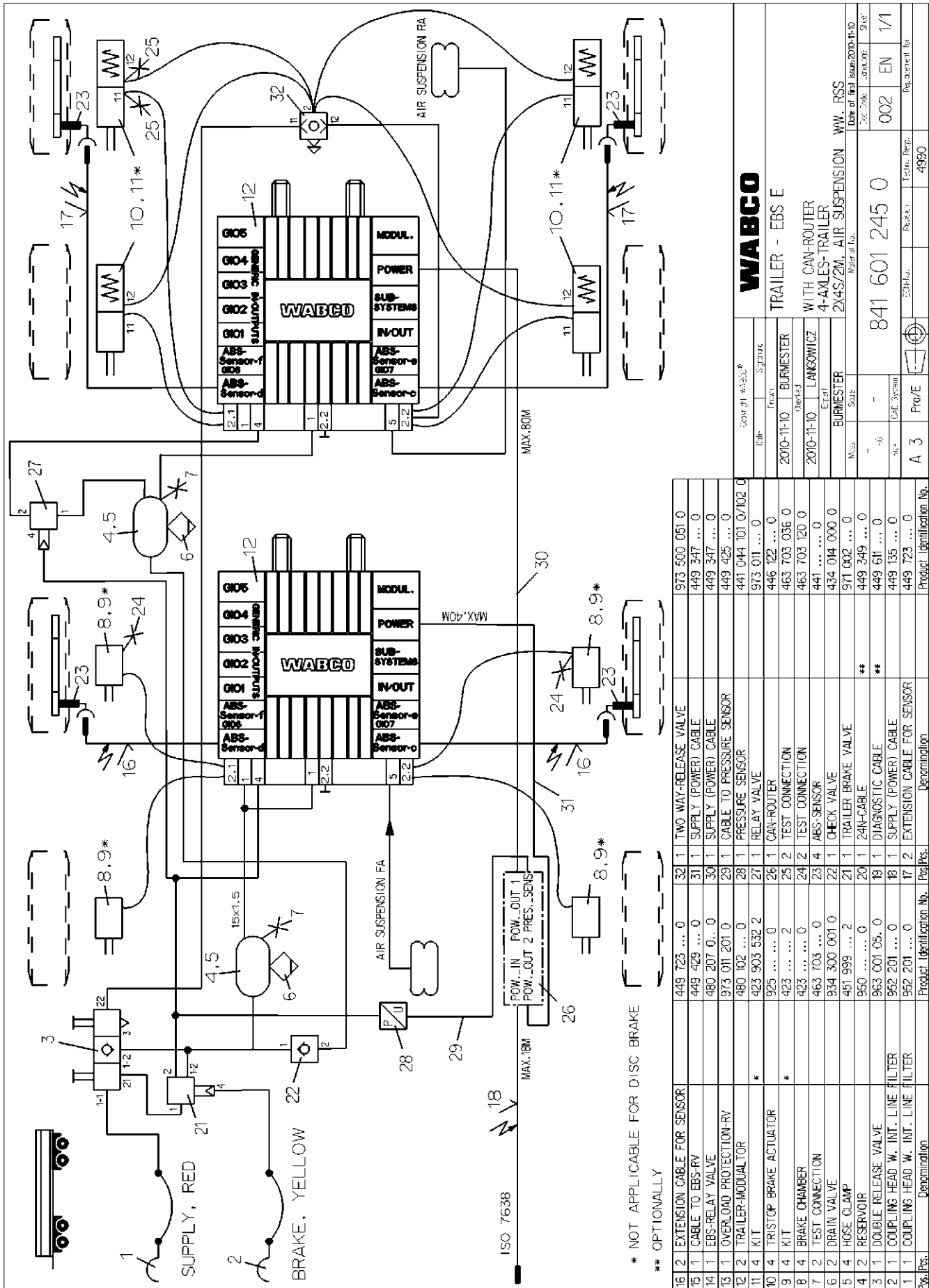

* NOT APPLICABLE FOR DISC BRAKE
 ** OPTIONALLY

16	2	EXTENSION CABLE FOR SENSOR	449 723 ... 0	32	1	TWO WAY-RELEASE VALVE	973 500 051 0
15	1	CABLE TO EBS-RV	449 429 ... 0	31	1	SUPPLY (POWER) CABLE	449 347 ... 0
14	1	EBS-RELAY VALVE	480 207 0.. 0	30	1	SUPPLY (POWER) CABLE	449 347 ... 0
13	1	OVERLOAD PROTECTION-RV	973 011 201 0	29	1	CABLE TO PRESSURE SENSOR	449 425 ... 0
12	2	TRAILER-MODULATOR	480 102 ... 0	28	1	PRESSURE SENSOR	441 044 101 0/102 0
11	4	KIT	423 903 532 2	27	1	RELAY VALVE	973 011 ... 0
10	4	TRISTOP BRAKE ACTUATOR	925 0	26	1	CAN-ROUTER	446 122 ... 0
9	4	KIT	423 2	25	2	TEST CONNECTION	463 703 036 0
8	4	BRAKE CHAMBER	423 0	24	2	TEST CONNECTION	463 703 120 0
7	2	TEST CONNECTION	463 703 ... 0	23	4	ABS-SENSOR	441 0
6	2	DRAIN VALVE	834 300 001 0	22	1	CHECK VALVE	434 014 000 0
5	4	HOSE CLAMP	451 999 ... 2	21	1	TRAILER BRAKE VALVE	971 002 ... 0
4	2	RESERVOIR	950 0	20	1	24N-CABLE	449 349 ... 0
3	1	DOUBLE RELEASE VALVE	963 001 05.. 0	19	1	DIAGNOSTIC CABLE	449 611 ... 0
2	1	COUPLING HEAD W. INT. LINE FILTER	952 201 ... 0	18	1	SUPPLY (POWER) CABLE	449 155 ... 0
1	1	COUPLING HEAD W. INT. LINE FILTER	952 201 ... 0	17	2	EXTENSION CABLE FOR SENSOR	449 723 ... 0

Denomination: Product Identification No. 1 Pos./Pos.
 Denomination: Product Identification No.

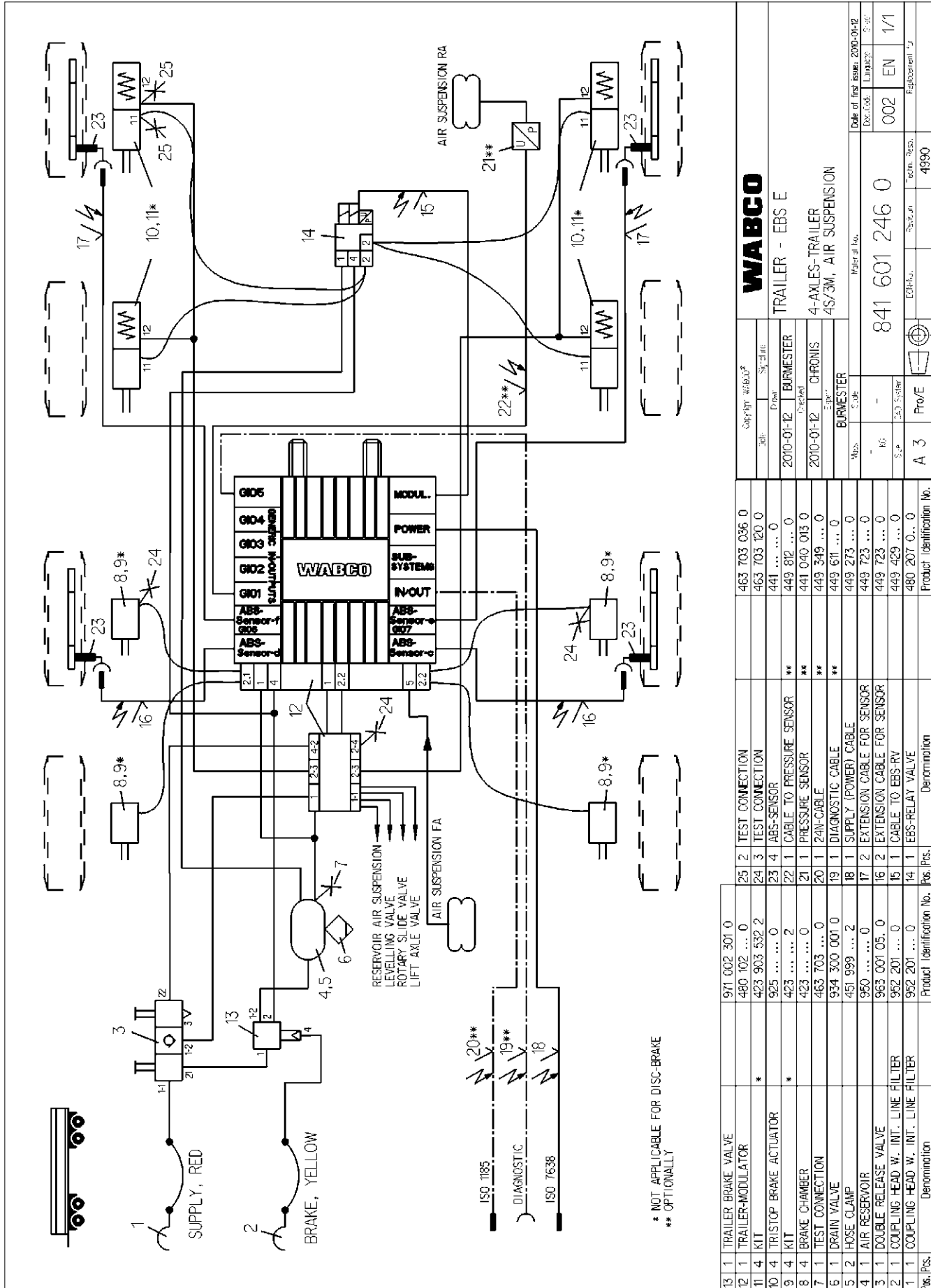

* NOT APPLICABLE FOR DISC-BRAKE
** OPTIONALLY

13	1	TRAILER BRAKE VALVE	971 602 301 0						
12	1	TRAILER-MODULATOR	480 102 ... 0	25	2	TEST CONNECTION	463 703 036 0		
11	4	KIT	423 903 532 2	24	3	TEST CONNECTION	463 703 120 0		
10	4	TRISTOP BRAKE ACTUATOR	925 0	23	4	ABS-SENSOR	441 0		
9	4	KIT	423 2	22	1	CABLE TO PRESSURE SENSOR	449 812 ... 0	**	
8	4	BRAKE CHAMBER	423 0	21	1	PRESSURE SENSOR	441 049 018 0	**	
7	1	TEST CONNECTION	463 703 ... 0	20	1	24M-CABLE	449 349 ... 0	**	
6	1	DRAIN VALVE	934 300 001 0	19	1	DIAGNOSTIC CABLE	449 611 ... 0	**	
5	2	HOSE CLAMP	451 999 ... 2	18	1	SUPPLY (POWER) CABLE	449 723 ... 0	**	
4	1	AIR RESERVOIR	963 001 05. 0	16	2	EXTENSION CABLE FOR SENSOR	449 723 ... 0		
3	1	DOUBLE RELEASE VALVE	952 201 ... 0	15	1	CABLE TO EBS-RV	449 429 ... 0		
2	1	COUPLING HEAD W. INT. LINE FILTER	952 201 ... 0	14	1	EBS-RELAY VALVE	480 207 0... 0		
1	1	COUPLING HEAD W. INT. LINE FILTER	952 201 ... 0						

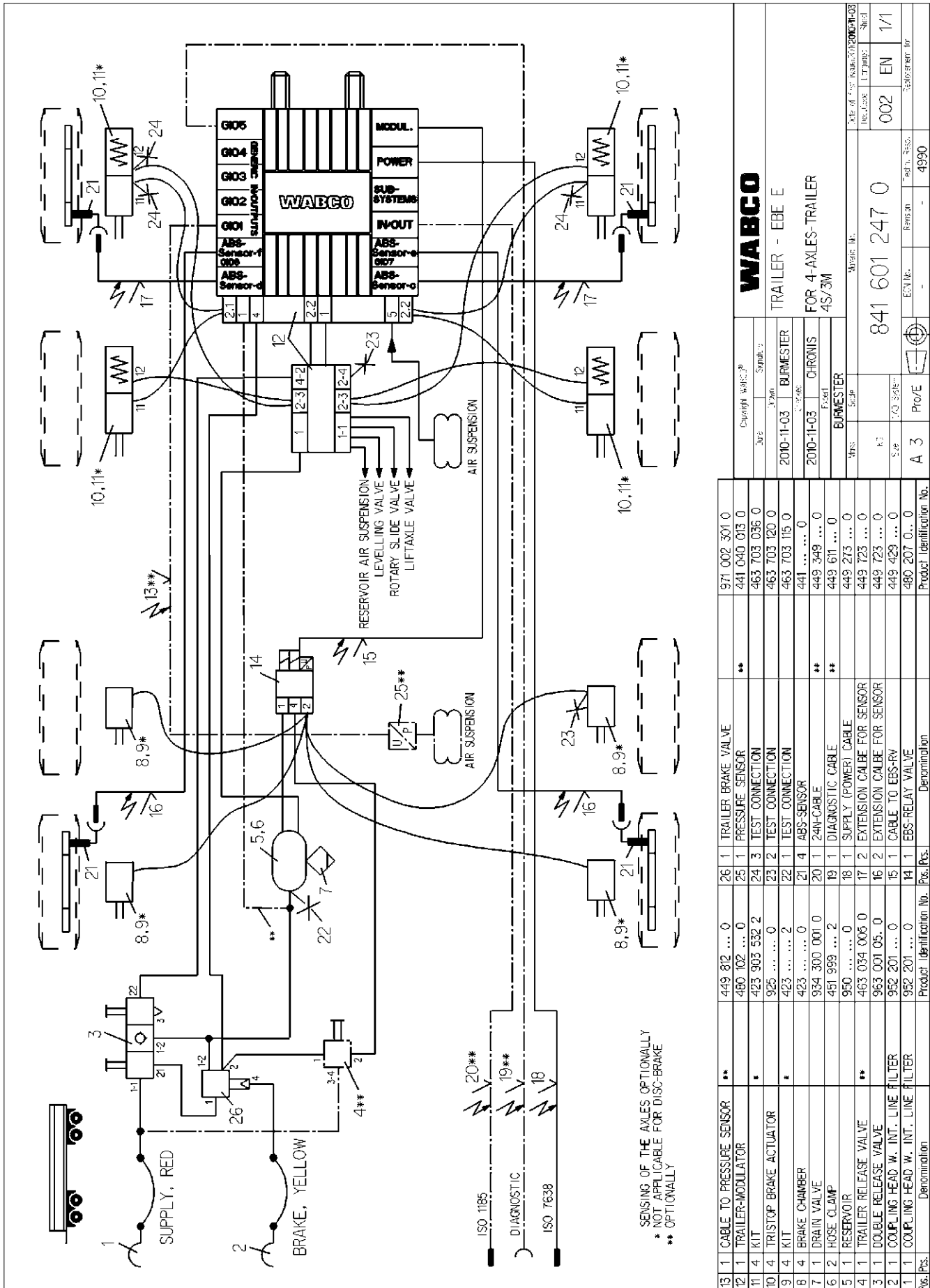

SENSING OF THE AXLES, OPTIONALLY
* NOT APPLICABLE FOR DISC-BRAKE
** OPTIONALLY

Fig. Pos.	Denomination	Product Identification No.	Pos. Pos.	Denomination	Product Identification No.	
13	CABLE TO PRESSURE SENSOR	**	449 812 ... 0	26	1 TRAILER BRAKE VALVE	971 002 301 0
12	1 TRAILER-MODULATOR	**	480 102 ... 0	25	1 PRESSURE SENSOR	441 040 013 0
11	4 KIT	*	423 903 532 2	24	3 TEST CONNECTION	463 703 036 0
10	4 TRISTOP BRAKE ACTUATOR	*	925 2	23	2 TEST CONNECTION	463 703 120 0
9	4 KIT	*	423 2	22	1 TEST CONNECTION	463 703 115 0
8	4 BRAKE CHAMBER		423 0	21	4 ABS-SENSOR	441 0
7	1 DRAIN VALVE		934 300 001 0	20	1 24V-CABLE	449 349 ... 0
6	2 HOSE CLAMP		451 999 ... 2	19	1 DIAGNOSTIC CABLE	449 611 ... 0
5	1 RESERVOIR		950 0	18	1 SUPPLY (POWER) CABLE	449 273 ... 0
4	1 TRAILER RELEASE VALVE	**	463 034 005 0	17	2 EXTENSION CALBE FOR SENSOR	449 123 ... 0
3	1 DOUBLE RELEASE VALVE		963 001 05.. 0	16	2 EXTENSION CALBE FOR SENSOR	449 123 ... 0
2	1 COUPLING HEAD W. INT. LINE FILTER		952 201 ... 0	15	1 CABLE TO EBS-RV	449 429 ... 0
1	1 COUPLING HEAD W. INT. LINE FILTER		952 201 ... 0	14	1 EBS-RELAY VALVE	480 207 0.. 0

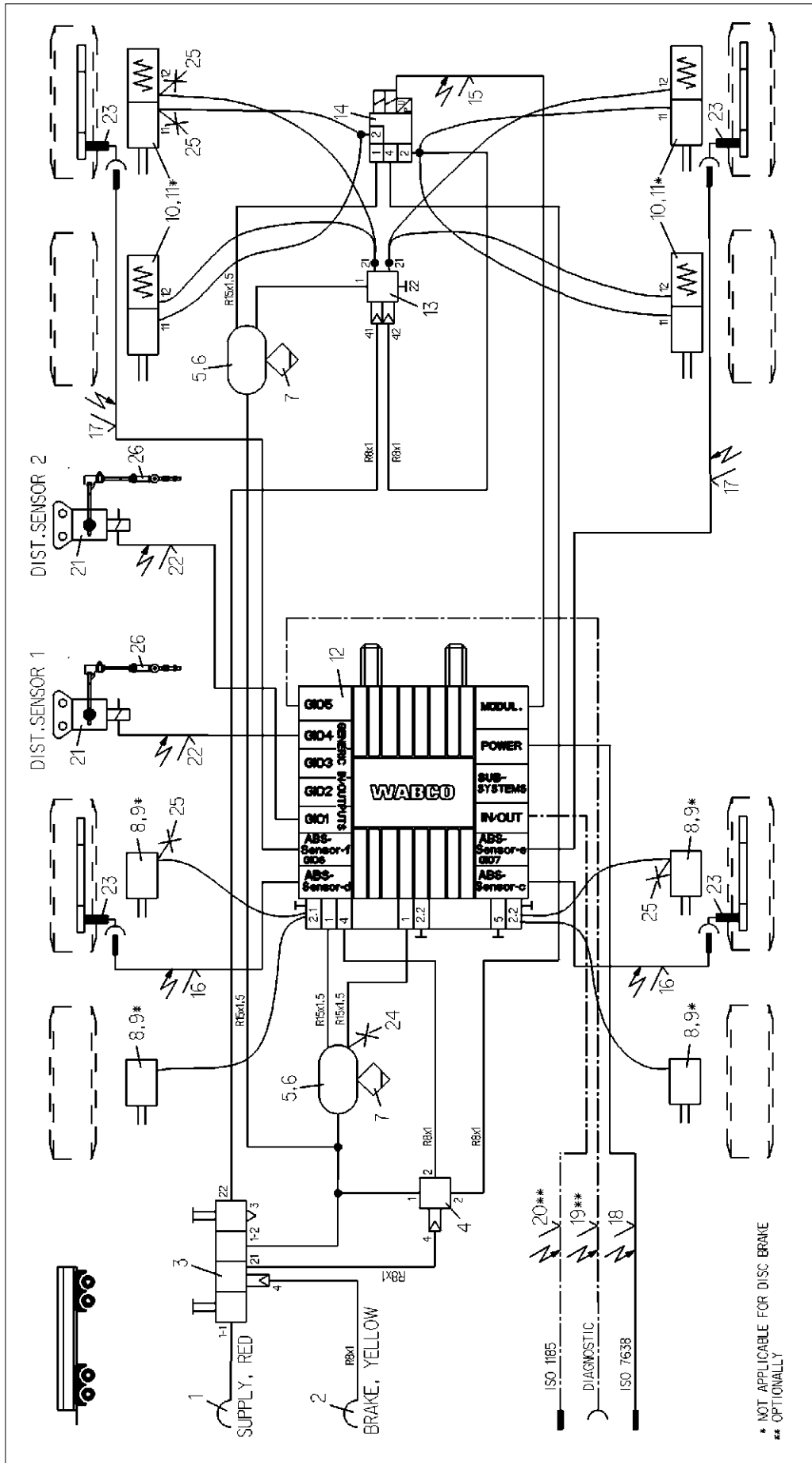

* NOT APPLICABLE FOR DISC BRAKE
** OPTIONALLY

Page Nos.	Denomination	Product identification No.	Pos. Pos.	Denomination	Product identification No.
13	1 OVERLOAD-PROTECTION-RV	973 011 201 0	26	2 LINKAGE	433 401 003 0
12	1 TRAILER-MODULATOR	480 102 ... 0	25	4 TEST CONNECTION	463 703 ... 0
11	4 KIT	423 903 532 2	24	1 TEST CONNECTION	463 703 ... 0
10	4 TRISTOP BRAKE ACTUATOR	925 0	23	4 ABS-SENSOR	441 0
9	4 KIT	423 2	22	2 GIO-CABLE-DISTANCE SENSOR	449 811 ... 0
8	4 BRAKE CHAMBER	423 0	21	2 DISTANCE SENSOR	441 050 100 0
7	2 DRAIN VALVE	934 300 001 0	20	1 2-AN-CABLE	449 349 ... 0
6	4 HOSE CLAMP	451 999 ... 2	19	1 DIAGNOSTIC CABLE	449 611 ... 0
5	2 AIR RESERVOIR	950 0	18	1 SUPPLY (POWER) CABLE	449 273 ... 0
4	1 RELAY VALVE	973 011 0 .. 0	17	2 EXTENSION CABLE FOR SENSOR	449 723 ... 0
3	1 PARK-RELEASE-EMERG.-VALVE (PREV)	971 002 9 .. 0	16	2 EXTENSION CABLE FOR SENSOR	449 723 ... 0
2	1 COUPLING HEAD W.INT. LINE FILTER	952 201 ... 0	15	1 CABLE TO EBS-RV	449 429 ... 0
1	1 COUPLING HEAD W.INT. LINE FILTER	952 201 ... 0	14	1 EBS-RELAY VALVE	480 207 0 .. 0

WABCO
TRAILER - EBS E
4-AXLES-TRAILER
4S/3M; RSS-FUNCTION (STEEL SUSPENSION)
Date of first issue: 2011-05-07
Rev. Code: 00000P
Page:
002 EN 1/1
Replaces: 841 601 249 0
EQUIV.:
EQUIV. Part. Reg.:
4990
HWR 00451

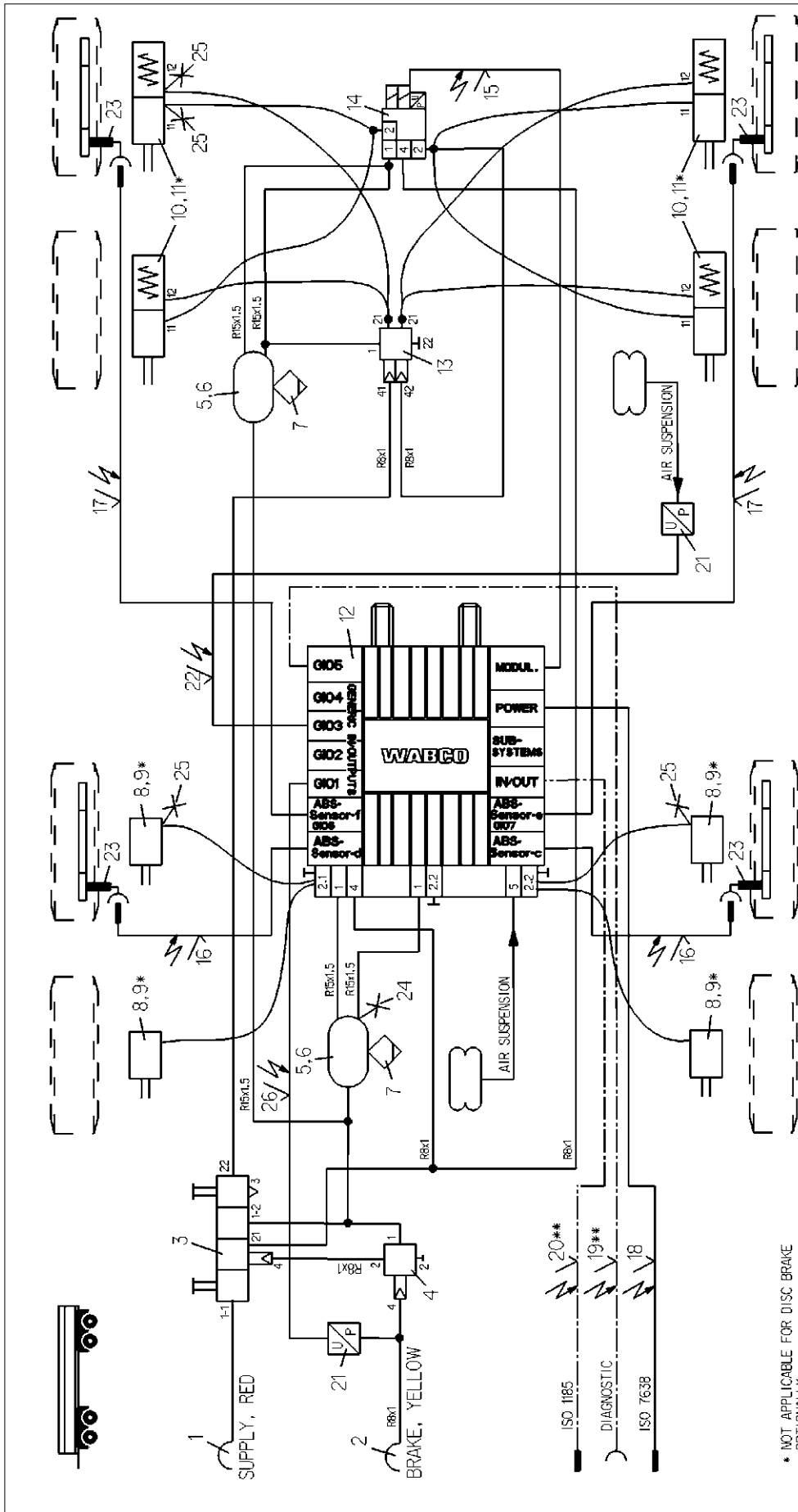

* NOT APPLICABLE FOR DISC BRAKE
 ** OPTIONALLY

13	1	OVERLOAD-PROTECTION-RV	973 011 201 0	26	1	GIO-CABLE-PRESSURE SENSOR	**	449 812 030 0
12	1	TRAILER-MODULATOR	480 102 ... 0	25	4	TEST CONNECTION		463 703 ... 0
11	4	KIT	423 903 532 2	24	1	TEST CONNECTION		463 703 ... 0
10	4	TRISTOP BRAKE ACTUATOR	925 0	23	4	ABS-SENSOR	**	441 0
9	4	KIT	423 2	22	1	GIO-CABLE-PRESSURE SENSOR	**	449 812 100 0
8	4	BRAKE CHAMBER	423 0	21	2	PRESSURE SENSOR	**	441 044 102 0
7	2	DRAIN VALVE	934 300 001 0	20	1	24N-CABLE	**	449 349 ... 0
6	4	HOSE CLAMP	451 999 ... 2	19	1	DIAGNOSTIC CABLE	**	449 611 ... 0
5	2	AIR RESERVOIR	950 0	18	1	SUPPLY (POWER) CABLE	**	449 273 ... 0
4	1	RELAY VALVE	973 011 0... 0	17	2	EXTENSION CABLE FOR SENSOR		449 723 ... 0
3	1	PARK-RELEASE-EMERG.-VALVE (PREV)	971 002 9... 0	16	2	EXTENSION CABLE FOR SENSOR		449 723 ... 0
2	1	COUPLING HEAD W.INT. LINE FILTER	952 201 ... 0	15	1	CABLE TO EBS-RV		480 207 0... 0
1	1	COUPLING HEAD W.INT. LINE FILTER	952 201 ... 0	14	1	EBS-RELAY VALVE		480 207 0... 0

Product Identification No.	Pos./Pos.	Denomination
449 812 030 0	**	GIO-CABLE-PRESSURE SENSOR
463 703 ... 0		TEST CONNECTION
463 703 ... 0		TEST CONNECTION
441 0	**	ABS-SENSOR
449 812 100 0	**	GIO-CABLE-PRESSURE SENSOR
441 044 102 0	**	PRESSURE SENSOR
449 349 ... 0	**	24N-CABLE
449 611 ... 0	**	DIAGNOSTIC CABLE
449 273 ... 0	**	SUPPLY (POWER) CABLE
449 723 ... 0		EXTENSION CABLE FOR SENSOR
449 723 ... 0		EXTENSION CABLE FOR SENSOR
480 207 0... 0		CABLE TO EBS-RV
480 207 0... 0		EBS-RELAY VALVE

City/Part No./Part	Signature	Date
WABCO		2011-03-29
Checked		
2011-03-29		
Signed		
BURMESTER		
Checked		
2011-03-29		
Signed		
BURMESTER		
Checked		
2011-03-29		
Signed		
BURMESTER		

Part No.	Part Name	Part No.	Part Name
841 601 350 0	TRAILER - EBS E	002	EN 1/1
DATE OF FIRST ISSUE	2011-03-29		
DATE OF LAST ISSUE			
DATE OF FIRST ISSUE	2011-03-29		
DATE OF LAST ISSUE			

Product Identification No.	Pos./Pos.	Denomination
449 812 030 0	**	GIO-CABLE-PRESSURE SENSOR
463 703 ... 0		TEST CONNECTION
463 703 ... 0		TEST CONNECTION
441 0	**	ABS-SENSOR
449 812 100 0	**	GIO-CABLE-PRESSURE SENSOR
441 044 102 0	**	PRESSURE SENSOR
449 349 ... 0	**	24N-CABLE
449 611 ... 0	**	DIAGNOSTIC CABLE
449 273 ... 0	**	SUPPLY (POWER) CABLE
449 723 ... 0		EXTENSION CABLE FOR SENSOR
449 723 ... 0		EXTENSION CABLE FOR SENSOR
480 207 0... 0		CABLE TO EBS-RV
480 207 0... 0		EBS-RELAY VALVE

Product Identification No.	Pos./Pos.	Denomination
449 812 030 0	**	GIO-CABLE-PRESSURE SENSOR
463 703 ... 0		TEST CONNECTION
463 703 ... 0		TEST CONNECTION
441 0	**	ABS-SENSOR
449 812 100 0	**	GIO-CABLE-PRESSURE SENSOR
441 044 102 0	**	PRESSURE SENSOR
449 349 ... 0	**	24N-CABLE
449 611 ... 0	**	DIAGNOSTIC CABLE
449 273 ... 0	**	SUPPLY (POWER) CABLE
449 723 ... 0		EXTENSION CABLE FOR SENSOR
449 723 ... 0		EXTENSION CABLE FOR SENSOR
480 207 0... 0		CABLE TO EBS-RV
480 207 0... 0		EBS-RELAY VALVE

Product Identification No.	Pos./Pos.	Denomination
449 812 030 0	**	GIO-CABLE-PRESSURE SENSOR
463 703 ... 0		TEST CONNECTION
463 703 ... 0		TEST CONNECTION
441 0	**	ABS-SENSOR
449 812 100 0	**	GIO-CABLE-PRESSURE SENSOR
441 044 102 0	**	PRESSURE SENSOR
449 349 ... 0	**	24N-CABLE
449 611 ... 0	**	DIAGNOSTIC CABLE
449 273 ... 0	**	SUPPLY (POWER) CABLE
449 723 ... 0		EXTENSION CABLE FOR SENSOR
449 723 ... 0		EXTENSION CABLE FOR SENSOR
480 207 0... 0		CABLE TO EBS-RV
480 207 0... 0		EBS-RELAY VALVE

Product Identification No.	Pos./Pos.	Denomination
449 812 030 0	**	GIO-CABLE-PRESSURE SENSOR
463 703 ... 0		TEST CONNECTION
463 703 ... 0		TEST CONNECTION
441 0	**	ABS-SENSOR
449 812 100 0	**	GIO-CABLE-PRESSURE SENSOR
441 044 102 0	**	PRESSURE SENSOR
449 349 ... 0	**	24N-CABLE
449 611 ... 0	**	DIAGNOSTIC CABLE
449 273 ... 0	**	SUPPLY (POWER) CABLE
449 723 ... 0		EXTENSION CABLE FOR SENSOR
449 723 ... 0		EXTENSION CABLE FOR SENSOR
480 207 0... 0		CABLE TO EBS-RV
480 207 0... 0		EBS-RELAY VALVE

Product Identification No.	Pos./Pos.	Denomination
449 812 030 0	**	GIO-CABLE-PRESSURE SENSOR
463 703 ... 0		TEST CONNECTION
463 703 ... 0		TEST CONNECTION
441 0	**	ABS-SENSOR
449 812 100 0	**	GIO-CABLE-PRESSURE SENSOR
441 044 102 0	**	PRESSURE SENSOR
449 349 ... 0	**	24N-CABLE
449 611 ... 0	**	DIAGNOSTIC CABLE
449 273 ... 0	**	SUPPLY (POWER) CABLE
449 723 ... 0		EXTENSION CABLE FOR SENSOR
449 723 ... 0		EXTENSION CABLE FOR SENSOR
480 207 0... 0		CABLE TO EBS-RV
480 207 0... 0		EBS-RELAY VALVE

Product Identification No.	Pos./Pos.	Denomination
449 812 030 0	**	GIO-CABLE-PRESSURE SENSOR
463 703 ... 0		TEST CONNECTION
463 703 ... 0		TEST CONNECTION
441 0	**	ABS-SENSOR
449 812 100 0	**	GIO-CABLE-PRESSURE SENSOR
441 044 102 0	**	PRESSURE SENSOR
449 349 ... 0	**	24N-CABLE
449 611 ... 0	**	DIAGNOSTIC CABLE
449 273 ... 0	**	SUPPLY (POWER) CABLE
449 723 ... 0		EXTENSION CABLE FOR SENSOR
449 723 ... 0		EXTENSION CABLE FOR SENSOR
480 207 0... 0		CABLE TO EBS-RV
480 207 0... 0		EBS-RELAY VALVE

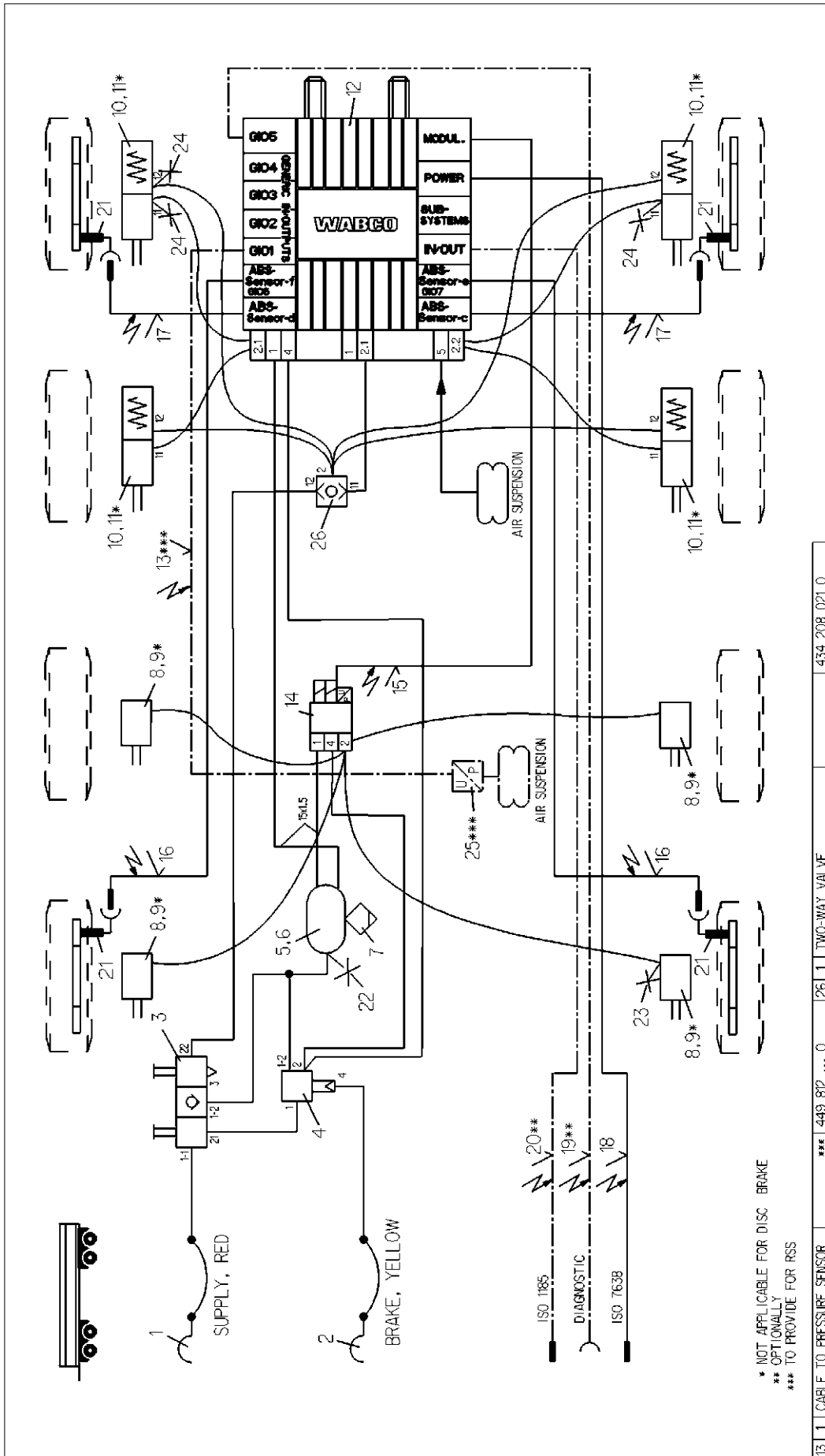

* NOT APPLICABLE FOR DISC BRAKE
 ** OPTIONALLY
 *** TO PROVIDE FOR RSS

Copyright WABCO		Date		Symbol's			
2012-04-16	BURMESTER	2012-04-16	CHRONIS	2012-04-16	BURMESTER		
OPTIONALLY RSS							
WABCO							
TRAILER - EBS E							
FOR 4-AXLES-TRAILER 4S/3M							
Part No. 841 601 352 0							
Doc. Code Ltr. page							
002 EN 1/1							
Revision for							
4990							
Product Identification No.							
Denomination							
Pos. Pos.							
13	1	CABLE TO PRESSURE SENSOR	449 812 ... 0	26	1	TWO-WAY VALVE	434 208 021 0
12	1	EBS-MODULATOR	480 102 ... 0	25	1	PRESSURE SENSOR	441 040 013 0
11	4	KIT	423 903 532 2	24	3	TEST CONNECTION	463 703 036 0
10	4	TRISTOP BRAKE ACTUATOR	925 ... 0	23	1	TEST CONNECTION	463 703 120 0
9	4	KIT	423 ... 2	22	1	TEST CONNECTION	463 703 115 0
8	4	BRAKE CHAMBER	423 ... 0	21	4	ABS-SENSOR	441 ... 0
7	1	DRAIN VALVE	934 300 001 0	20	1	24N-CABLE	449 349 ... 0
6	2	HOSE CLAMP	451 989 ... 2	19	1	DIAGNOSTIC CABLE	449 611 ... 0
5	1	AIR RESERVOIR	950 ... 0	18	1	SUPPLY (POWER) CABLE	449 273 ... 0
4	1	TRAILER BRAKE VALVE	971 002 301 0	17	2	EXTENSION CABLE FOR SENSOR	449 723 ... 0
3	1	DOUBLE RELEASE VALVE	963 001 05. 0	16	2	EXTENSION CABLE FOR SENSOR	449 723 ... 0
2	1	COUPLING HEAD W.INT. LINE FILTER	952 201 ... 0	15	1	CABLE TO EBS-RV	449 429 ... 0
1	1	COUPLING HEAD W.INT. LINE FILTER	952 201 ... 0	14	1	EBS-RELAY VALVE	480 207 0. 0
Product Identification No.						Product Identification No.	
Denomination						Denomination	
Pos. Pos.						Pos. Pos.	

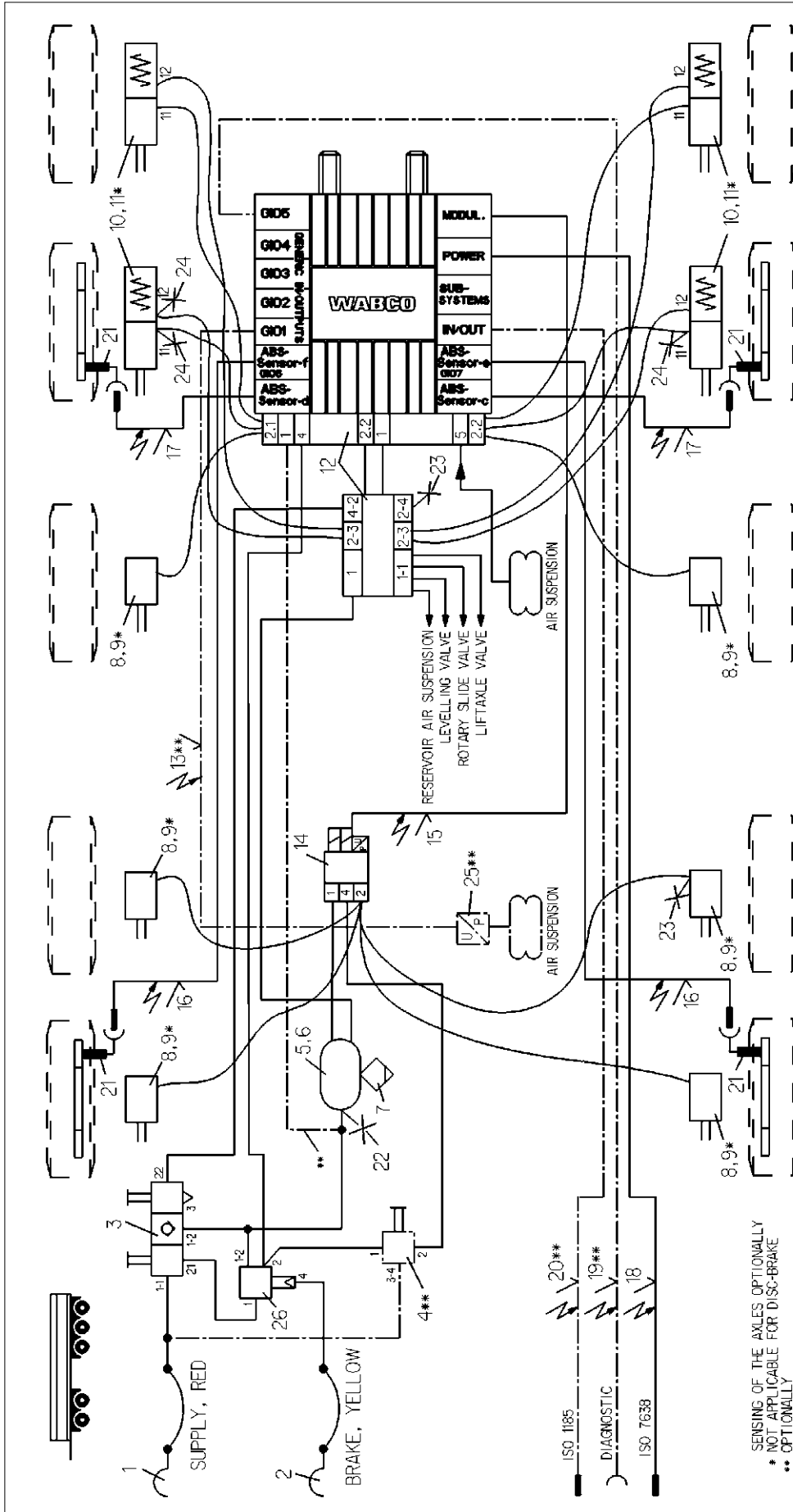

SENSING OF THE AXLES OPTIONALLY
 * NOT APPLICABLE FOR DISC-BRAKE
 ** OPTIONALLY

Pos. Pos.	Denomination	Product Identification No.	Pos. Pos.	Denomination	Product Identification No.
13 1	CABLE TO PRESSURE SENSOR	**	449 812 ... 0	26 1	TRAILER BRAKE VALVE
12 1	TRAILER-MODULATOR		480 102 ... 0	25 1	PRESSURE SENSOR
11 4	KIT	*	423 903 532 2	24 3	TEST CONNECTION
10 4	TRISTOP BRAKE ACTUATOR		925 ... 0	23 2	TEST CONNECTION
9 6	KIT	*	423 ... 2	22 1	TEST CONNECTION
8 6	BRAKE CHAMBER		423 ... 0	21 4	ABS-SENSOR
7 1	DRAIN VALVE		934 300 001 0	20 1	24V-CABLE
6 2	HOSE CLAMP		451 999 ... 2	19 1	DIAGNOSTIC CABLE
5 1	RESERVOIR		950 ... 0	18 1	SUPPLY (POWER) CABLE
4 1	TRAILER RELEASE VALVE	**	463 034 005 0	17 2	EXTENSION CABLE FOR SENSOR
3 1	DOUBLE RELEASE VALVE		963 001 05 0	16 2	EXTENSION CABLE FOR SENSOR
2 1	COUPLING HEAD W. INT. LINE FILTER		952 201 ... 0	15 1	CABLE TO EBS-RV
1 1	COUPLING HEAD W. INT. LINE FILTER		952 201 ... 0	14 1	EBS-RELAY VALVE

WABCO TRAILER - EBE E FOR 5-AXLES-TRAILER 4S/3M	
Part No.	841 601 063 0
Doc. Code	1 1000000
Material No.	
Part No.	841 601 063 0
Doc. Code	1 1000000
Material No.	
Part No.	841 601 063 0
Doc. Code	1 1000000
Material No.	
Part No.	841 601 063 0
Doc. Code	1 1000000
Material No.	
Part No.	841 601 063 0
Doc. Code	1 1000000
Material No.	

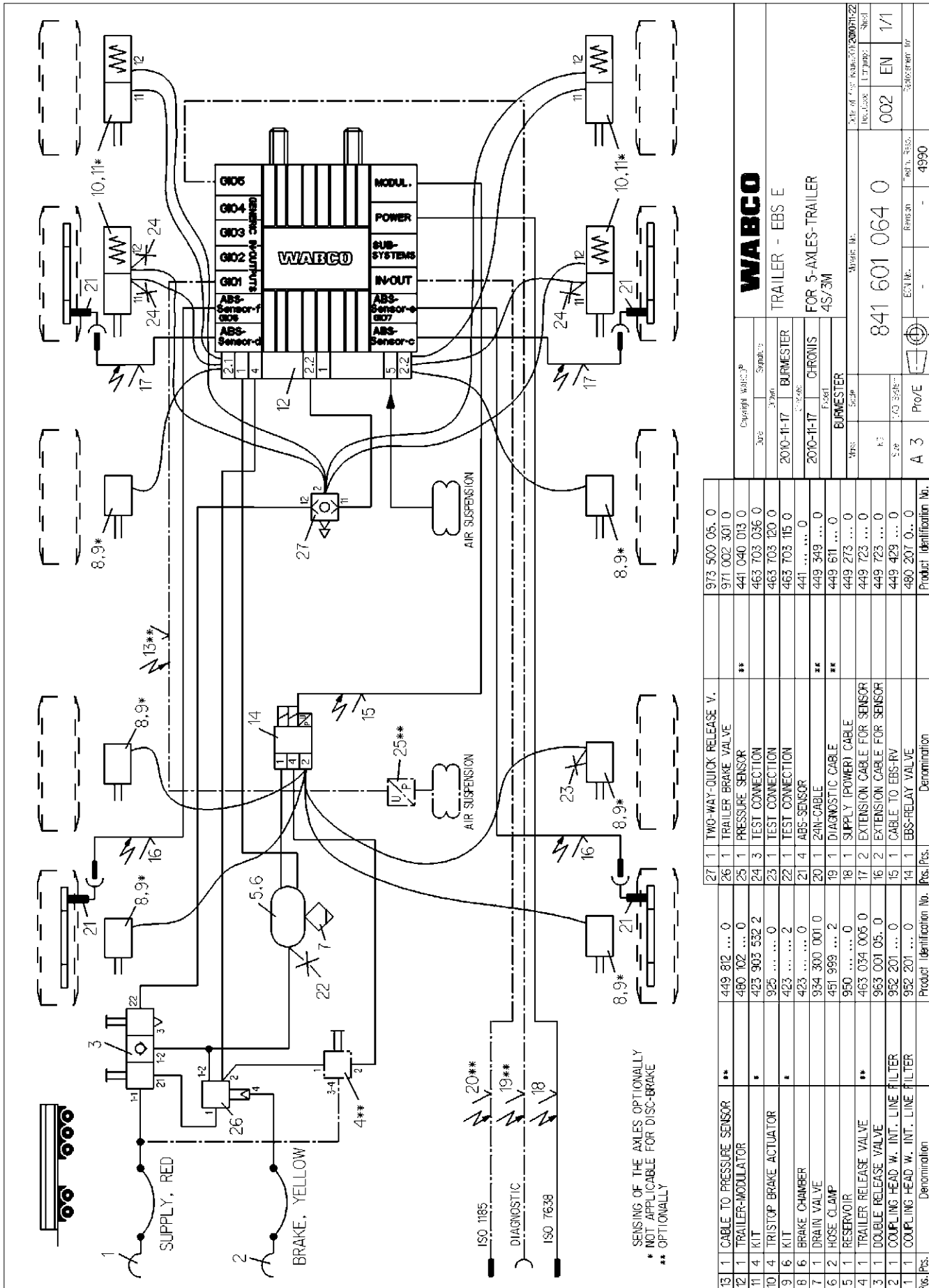

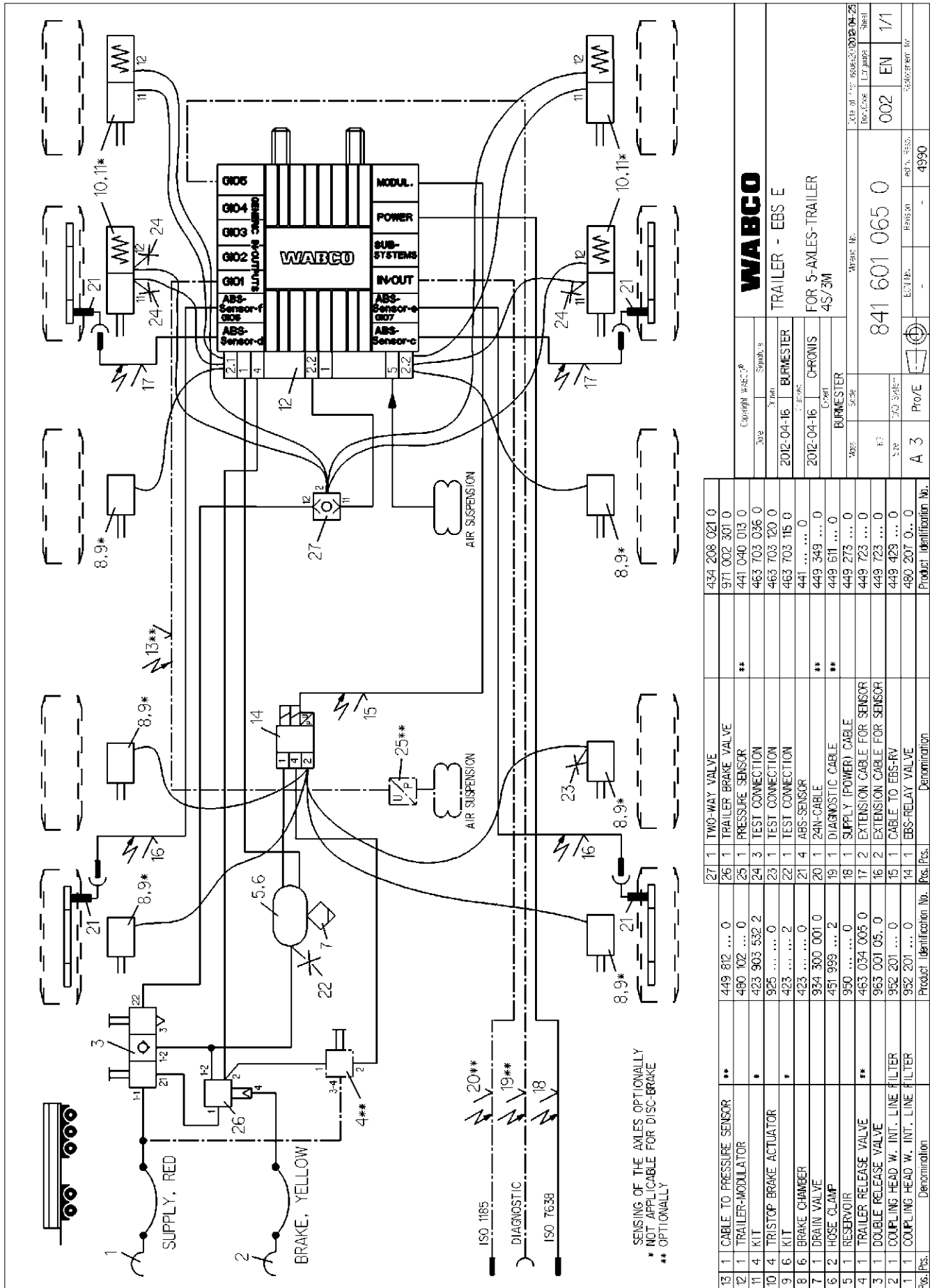

WABCO
TRAILER - EBS E
FOR 5-AXLES-TRAILER
4S/3M

Fig. Pos.	Denomination	Pos. Pos.	Denomination	Product Identification No.	
13	1 CABLE TO PRESSURE SENSOR **	434 208 021 0	27 1	1 TWO-WAY VALVE	434 208 021 0
12	1 TRAILER-MODULATOR	971 002 301 0	26 1	1 TRAILER BRAKE VALVE	971 002 301 0
11	4 KIT *	441 040 013 0	25 1	1 PRESSURE SENSOR **	441 040 013 0
10	4 TRISTOP BRAKE ACTUATOR	463 703 036 0	24 3	1 TEST CONNECTION	463 703 036 0
9	6 KIT *	463 703 120 0	23 1	1 TEST CONNECTION	463 703 120 0
8	6 BRAKE CHAMBER	463 703 115 0	22 1	1 TEST CONNECTION	463 703 115 0
7	1 DRAIN VALVE	441 0	21 4	1 ABS-SENSOR	441 0
6	2 HOSE CLAMP	449 349 ... 0	20 1	1 24N-CABLE	449 349 ... 0
5	1 RESERVOIR	449 611 ... 0	19 1	1 DIAGNOSTIC CABLE	449 611 ... 0
4	1 TRAILER RELEASE VALVE **	449 273 ... 0	18 1	1 SUPPLY (POWER) CABLE	449 273 ... 0
3	1 DOUBLE RELEASE VALVE	463 034 005 0	17 2	1 EXTENSION CABLE FOR SENSOR	463 034 005 0
2	1 COUPLING HEAD W. INT. LINE FILTER	963 001 05 0	16 2	1 EXTENSION CABLE FOR SENSOR	963 001 05 0
1	1 COUPLING HEAD W. INT. LINE FILTER	952 201 ... 0	15 1	1 CABLE TO EBS-RV	952 201 ... 0
		480 201 0... 0	14 1	1 EBS-RELAY VALVE	480 201 0... 0
			13	1 CABLE TO PRESSURE SENSOR **	434 208 021 0
			12	1 TRAILER-MODULATOR	971 002 301 0
			11	4 KIT *	441 040 013 0
			10	4 TRISTOP BRAKE ACTUATOR	463 703 036 0
			9	6 KIT *	463 703 120 0
			8	6 BRAKE CHAMBER	463 703 115 0
			7	1 DRAIN VALVE	441 0
			6	2 HOSE CLAMP	449 349 ... 0
			5	1 RESERVOIR	449 611 ... 0
			4	1 TRAILER RELEASE VALVE **	449 273 ... 0
			3	1 DOUBLE RELEASE VALVE	463 034 005 0
			2	1 COUPLING HEAD W. INT. LINE FILTER	963 001 05 0
			1	1 COUPLING HEAD W. INT. LINE FILTER	952 201 ... 0
					480 201 0... 0

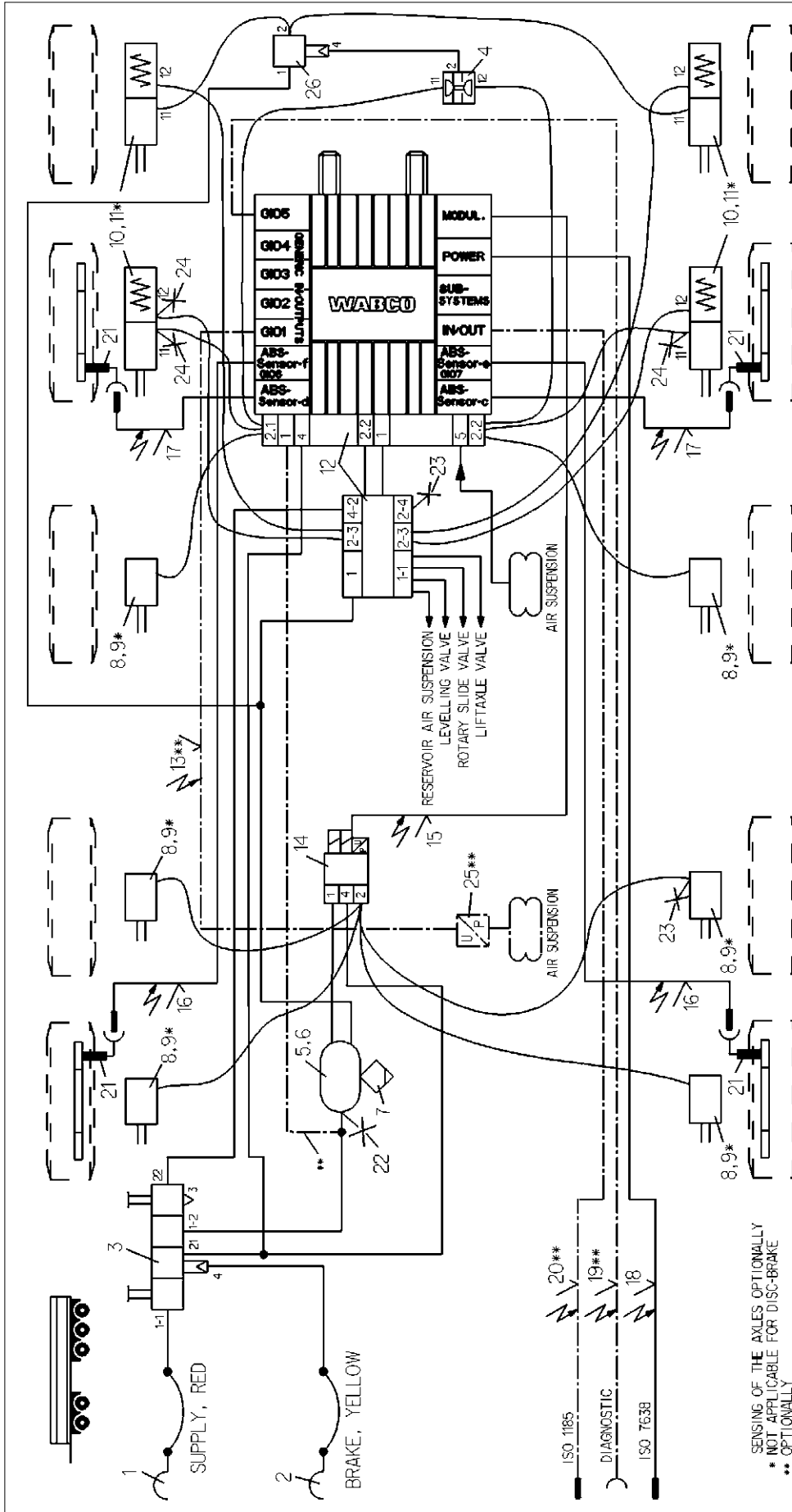

SENSING OF THE AXLES OPTIONALLY
 * NOT APPLICABLE FOR DISC-BRAKE
 ** OPTIONAL

Cable No.		Cable No.		Cable No.		Cable No.	
13	12	11	10	9	8	7	6
1	1	1	1	1	1	1	1
CABLE TO PRESSURE SENSOR	TRAILER-MODULATOR	TRISTOP BRAKE ACTUATOR	BRAKE CHAMBER	DRAIN VALVE	HOSE CLAMP	RESERVOIR	DOUBLE SHUT-OFF VALVE
449 812 ... 0	480 102 ... 0	423 903 532 2	925 ... 0	423 ... 0	934 300 001 0	451 999 ... 2	434 500 003 0
**	*	*	*	*	*	*	*
26 1	25 1	24 3	23 2	22 1	20 1	19 1	18 1
RELAY VALVE	PRESSURE SENSOR	TEST CONNECTION	TEST CONNECTION	TEST CONNECTION	ABS-SENSOR	DIAGNOSTIC CABLE	SUPPLY (POWER) CABLE
973 011 000 0	441 040 013 0	463 703 036 0	463 703 120 0	463 703 115 0	441 ... 0	449 349 ... 0	449 611 ... 0
**	**	**	**	**	**	**	**
2	3	4	5	6	7	8	9
TRIPPER	TRIPPER	TRIPPER	TRIPPER	TRIPPER	TRIPPER	TRIPPER	TRIPPER
2012-05-02	2012-05-02	2012-05-02	2012-05-02	2012-05-02	2012-05-02	2012-05-02	2012-05-02
BURMESTER	BURMESTER	BURMESTER	BURMESTER	BURMESTER	BURMESTER	BURMESTER	BURMESTER
<p>WABCO TRAILER - EBE E FOR 5-AXLES-TRAILER 4S/3M SELECT LOW</p>							
<p>WABCO No. 841 601 066 0</p>							
<p>DATE OF FIRST SUPPLY 2006-06-07</p>							
<p>002 EN 1/1</p>							
<p>4990</p>							

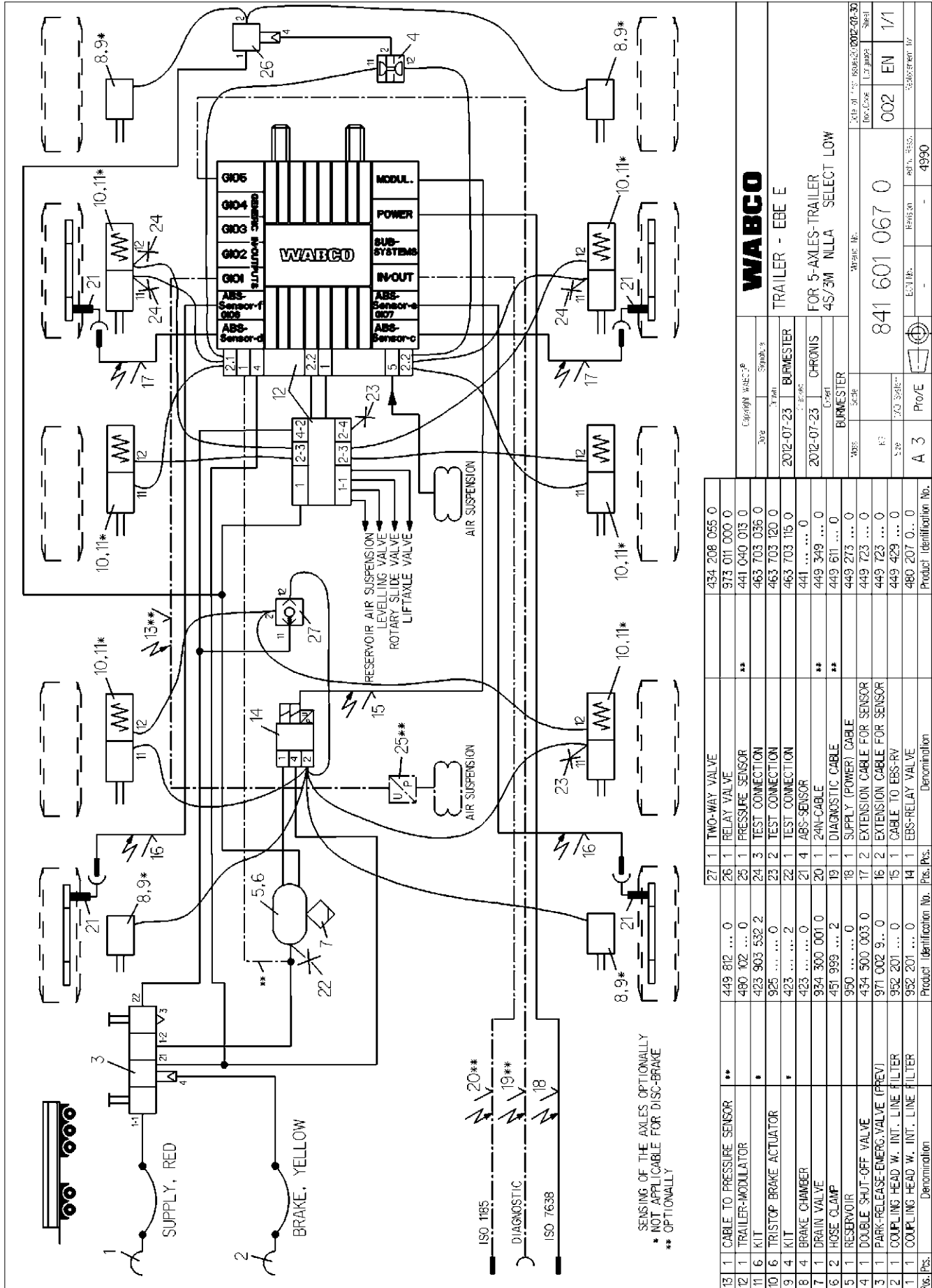

SENSING OF THE AXLES OPTIONALLY
 * NOT APPLICABLE FOR DISC-BRAKE
 ** OPTIONALLY

WABCO

TRAILER - EBE E
 FOR 5-AXLES-TRAILER
 4S/3M NLLA SELECT LOW

Fig. Pos.	Denomination	Product Identification No.	Pos. Pos.	Denomination	Product Identification No.	
13	1 CABLE TO PRESSURE SENSOR	**	449 812 ... 0	27	1 TWO-WAY VALVE	434 208 055 0
12	1 TRAILER-MODULATOR	**	480 102 ... 0	26	1 RELAY VALVE	973 011 000 0
11	6 KIT	*	423 903 532 2	25	1 PRESSURE SENSOR	441 040 013 0
10	6 TRISTOP BRAKE ACTUATOR	*	925 ... 2	24	3 TEST CONNECTION	463 703 036 0
9	4 KIT	*	423 ... 2	23	2 TEST CONNECTION	463 703 720 0
8	4 BRAKE CHAMBER		423 ... 0	22	1 TEST CONNECTION	463 703 115 0
7	1 DRAIN VALVE		934 300 001 0	21	4 ABS-SENSOR	441 ... 0
6	2 HOSE CLAMP		451 999 ... 2	20	1 24V-CABLE	449 349 ... 0
5	1 RESERVOIR		950 ... 0	19	1 DIAGNOSTIC CABLE	449 611 ... 0
4	1 DOUBLE SHUT-OFF VALVE		434 500 003 0	18	1 SUPPLY (POWER) CABLE	449 273 ... 0
3	1 PARK-RELEASE-EMERG.VALVE (PREV)		971 002 9... 0	17	2 EXTENSION CABLE FOR SENSOR	449 723 ... 0
2	1 COUPLING HEAD W. INT. LINE FILTER		952 201 ... 0	16	2 EXTENSION CABLE FOR SENSOR	449 723 ... 0
1	1 COUPLING HEAD W. INT. LINE FILTER		952 201 ... 0	15	1 CABLE TO EBS-RV	449 429 ... 0
				14	1 EBS-RELAY VALVE	480 207 0... 0

Doc. Code	Lit. Code	Version	Year
		002	EN
		1/1	

Year	Part No.	Part Name
2012-07-23	BURMESTER	
2012-07-23	CHRONIS	
	BURMESTER	

Year	Part No.	Part Name
2012-07-23	BURMESTER	
2012-07-23	CHRONIS	
	BURMESTER	

Year	Part No.	Part Name
2012-07-23	BURMESTER	
2012-07-23	CHRONIS	
	BURMESTER	

Year	Part No.	Part Name
2012-07-23	BURMESTER	
2012-07-23	CHRONIS	
	BURMESTER	

Year	Part No.	Part Name
2012-07-23	BURMESTER	
2012-07-23	CHRONIS	
	BURMESTER	

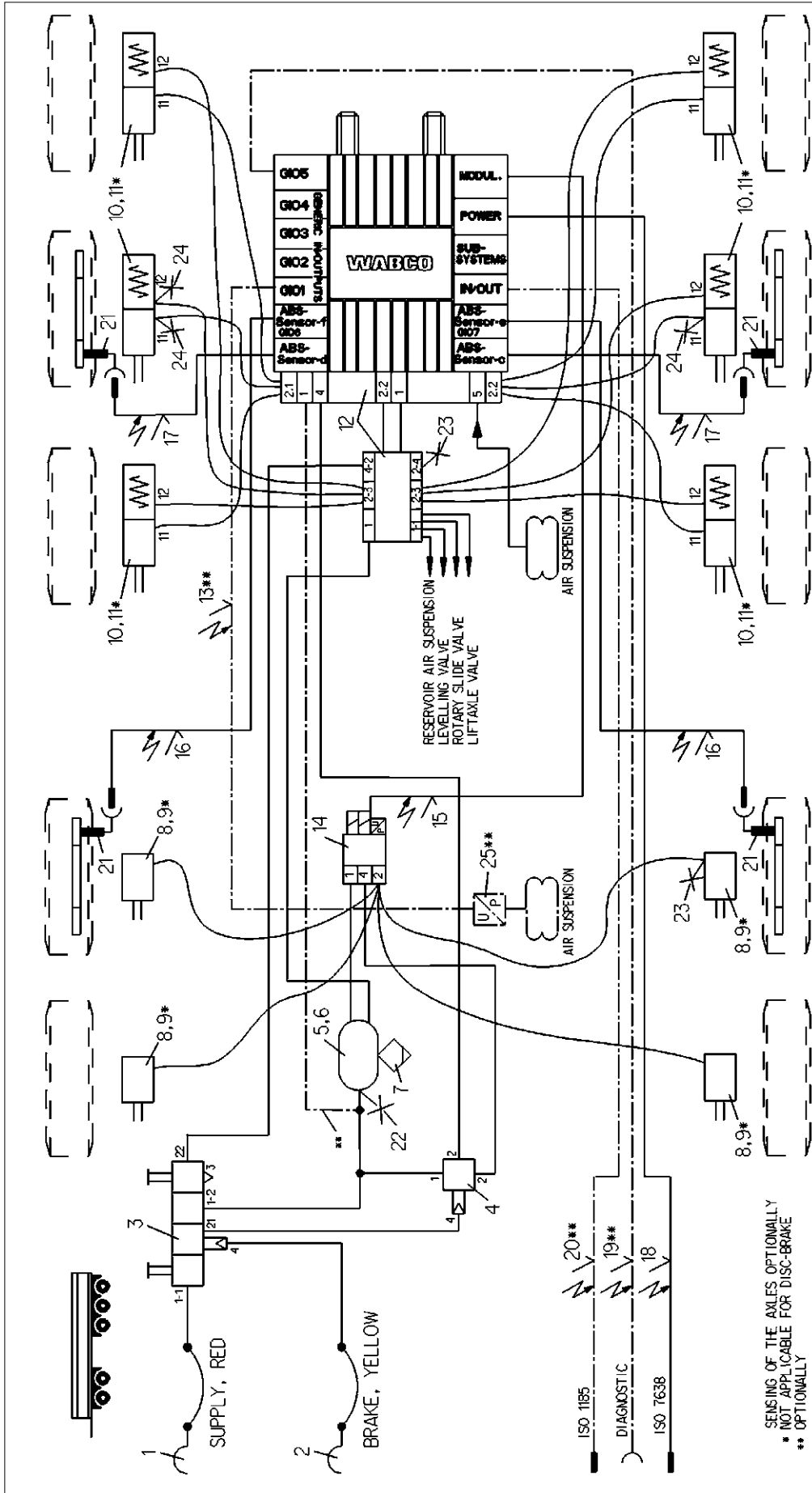

SENSING OF THE AXLES OPTIONALLY
 * NOT APPLICABLE FOR DISC-BRAKE
 ** OPTIONALLY

Copyright WABCO®		Signatures			
Date	Drawn	Date	Checked		
2014-01-21	BURMESTER	2014-01-21	CHRONIS		
Expert		Expert			
Scale		Scale			
Mass		Mass			
kg		kg			
Size		Size			
CAD System		CAD System			
A 3		A 3			
Pro/E		Pro/E			
ECH-№.		ECH-№.			
-		-			
Revision		Revision			
-		-			
Termin. Resp.		Termin. Resp.			
4990		4990			
Material No.		Material No.			
841 601 069 0		841 601 069 0			
Doc.Code		Doc.Code			
002		002			
Language		Language			
EN		EN			
Sheet		Sheet			
1/1		1/1			
Date of first issue: 2013-03-01-21		Date of first issue: 2013-03-01-21			
WABCO					
TRAILER - EBE E					
FOR 5-AXLES-TRAILER					
4S/3M					
Fig. No.	Denomination	Product Identification No.	Pos. / Pos.	Denomination	Product Identification No.
13	1 CABLE TO PRESSURE SENSOR	449 812 ... 0	**	1	441 040 013 0
12	1 TRAILER-MODULATOR	480 102 ... 0	**	25	463 703 036 0
11	6 KIT	423 903 532 2	*	24	463 703 120 0
10	6 TRISTOP BRAKE ACTUATOR	925 ... 0		23	463 703 115 0
9	4 KIT	423 ... 2	*	22	441 ... 0
8	4 BRAKE CHAMBER	423 ... 0		21	449 349 ... 0
7	1 DRAIN VALVE	934 300 001 0		20	449 611 ... 0
6	2 HOSE CLAMP	451 999 ... 2	**	19	449 273 ... 0
5	1 RESERVOIR	950 ... 0		18	449 723 ... 0
4	1 RELAY VALVE	973 011 000 0		17	449 723 ... 0
3	1 PARK-RELEASE-EMERG.VALVE (PREV)	971 002 9... 0		16	449 723 ... 0
2	1 COUPLING HEAD W. INT. LINE FILTER	952 201 ... 0		15	449 429 ... 0
1	1 COUPLING HEAD W. INT. LINE FILTER	952 201 ... 0		14	480 207 0... 0

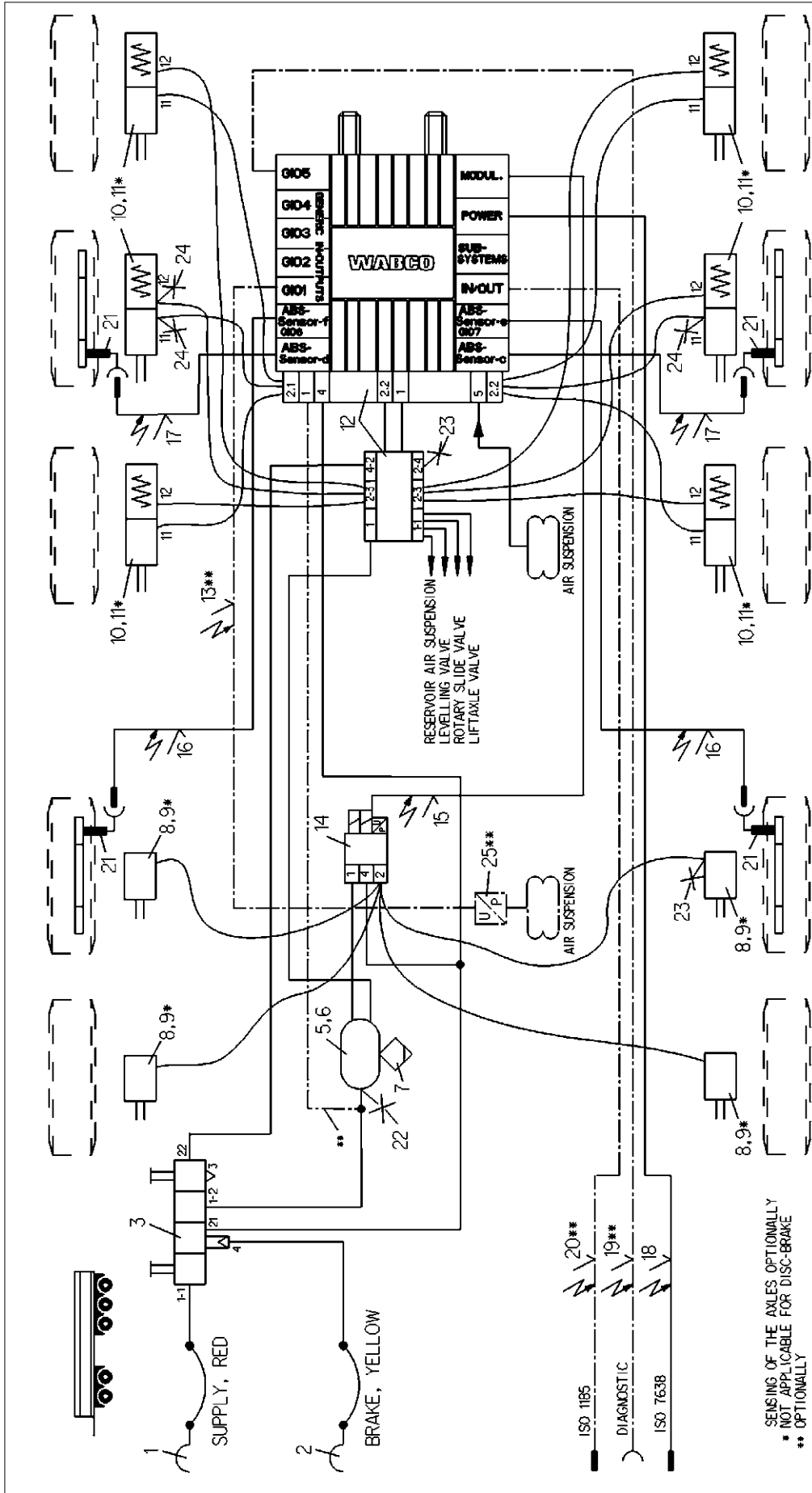

SENSING OF THE AXLES OPTIONALLY
 * NOT APPLICABLE FOR DISC-BRAKE
 ** OPTIONALLY

Copyright WABCO®		Date		Signature	
Date		Drawn		Checked	
2014-01-27		BURMESTER		CHRONIS	
2014-01-27		BURMESTER		BURMESTER	
Date of first issue: 2014-01-27		Doc-Code		Language	
002		EN		1/1	
841 601 380 0		Material No.		Tech. Resp.	
A 3		Pro/E		4990	
Product Identification No.		Denomination		Product Identification No.	
13	1	CABLE TO PRESSURE SENSOR	**	449 812 ... 0	441 040 013 0
12	1	TRAILER-MODULATOR	**	480 102 ... 0	463 703 036 0
11	6	KIT	*	423 903 532 2	463 703 120 0
10	6	TRISTOP BRAKE ACTUATOR	*	923 ... 0	463 703 115 0
9	4	KIT	*	423 ... 2	441 ... 0
8	4	BRAKE CHAMBER	*	423 ... 0	449 349 ... 0
7	1	DRAIN VALVE	*	934 300 001 0	449 611 ... 0
6	2	HOSE CLAMP	*	451 999 ... 2	449 273 ... 0
5	1	RESERVOIR	*	950 ... 0	449 723 ... 0
4	1	PARK-RELEASE-EMERG. VALVE (PREV)	*	971 002 9... 0	449 723 ... 0
3	1	COUPLING HEAD W. INT. LINE FILTER	*	952 201 ... 0	449 429 ... 0
2	1	COUPLING HEAD W. INT. LINE FILTER	*	952 201 ... 0	480 207 0... 0
1	1	COUPLING HEAD W. INT. LINE FILTER	*	952 201 ... 0	
Fig. Pos.	Denomination	Product Identification No.	Pos. Pos.	Denomination	Product Identification No.



TRAILER - EBE E
 FOR 5-AXLES-TRAILER
 4S/3M



WABCO
a **WORLD** of
DIFFERENCE

WABCO (NYSE: WBC) is a leading global supplier of technologies and services that improve the safety, efficiency and connectivity of commercial vehicles. Founded nearly 150 years ago, WABCO continues to pioneer breakthrough innovations for advanced driver assistance, braking, stability control, suspension, transmission automation and aerodynamics. Partnering with the transportation industry as it maps a route

towards autonomous driving, WABCO also uniquely connects trucks, trailers, drivers, cargo, and fleet operators through telematics, as well as advanced fleet management and mobile solutions. WABCO reported sales of \$2.6 billion in 2015. Headquartered in Brussels, Belgium, WABCO has 12,000 employees in 39 countries. For more information, visit

www.wabco-auto.com