

Air Braking Equipment | for Trailers



WABCO

Air Braking Equipment

**for Trailers
according to Council Directive
71/320/ EEC Catalogue for Trailers**

Diagrammatic Views and Description
of Braking Systems and Air Braking
Equipment

Edition 3

This publication is not subject to any update service.
You will find the latest version in INFORM
www.wabco-auto.com

© 2010

WABCO

Table of Contents

1	Instructions and safety instructions	6
1.1	Symbols used	6
1.2	Avoiding electro-static charge and uncontrolled discharging (ESD)	6
1.3	Information and Disclaimer	7
2	Introduction	8
3	General Information	9
4	Diagram	12
4.1	VCS II brake diagram	12
4.2	Trailer EBS E brake diagram	16
4.3	Lift axle circuits	30
4.4	Air suspension	32
5	Device description	39
5.1	Brake chamber 423 ...	39
5.2	Line filter 432 500	47
5.3	Exhaust filter 432 70.	49
5.4	Knuckle joint 433 306	50
5.5	Linkage 433 401	53
5.6	Check valve 434 014	54
5.7	Charging valve 434 100	55
5.8	Two-way valve 434 208	57
5.9	Pressure switch 441 009 / 441 014	59
5.10	Pressure sensor 441 044	62
5.11	Shut-off cock with venting 452 002 / 952 002	63
5.12	Dummy coupling with fastening 452 402	65
5.13	Duo-Matic quick-coupling 452 80.	66
5.14	Rotary slide valve 463 032	70
5.15	3/2-way valve 463 036	73
5.16	Lift axle control valve 463 084	75
5.17	TASC – Return-to-Ride valve 463 090	84
5.18	Damping reservoir 463 084 020 2	88
5.19	Test connection 463 703	89
5.20	Levelling valve 464 006	91
5.21	3/2-way solenoid valve 472 1..	97
5.22	Pressure reducing valve 473 301	101
5.23	Quick release valve 473 501 / 973 500	103
5.24	Pressure limiting valve 475 010	107
5.25	Automatic load-dependent load sensing valve (LSV) 475 71.	109
5.26	Load-dependent control valve 475 800	134

Table of Contents

5.27	Tristop® Cylinder 925 ...	138
5.28	Drain valve 934 300 / 934 301	146
5.29	Air reservoir 950 ...	149
5.30	Hose coupling 952 20. / 452 ...	152
5.31	Trailer release valve 963 001 / 963 006	158
5.32	Shut-off valve 964 001	162
5.33	Trailer control valve with adjustable predominance 971 002	166
5.34	Park-release emergency valve (PREV) 971 002	175
5.35	Relay valve 973 0..	178
5.36	Proportioning pressure regulator 975 001 / 975 002	184
6	Disposal	190

1 Instructions and safety instructions

1.1 Symbols used

DANGER

Imminent hazard situation which can cause serious personal injury or death if the safety instruction is not observed.

WARNING

Potential hazard situation which can cause death or serious personal injury if the safety instruction is not observed.

CAUTION

Potential hazard situations that can cause minor or moderate personal injury if the safety instruction is not observed.



Important instructions, information, or tips that you should always observe.



Reference to information, publications etc. on the Internet

- List
- Step
- ➔ Consequence of an action

1.2 Avoiding electro-static charge and uncontrolled discharging (ESD)

Note during construction and building the vehicle:

- Prevent potential differences between components (e. g. axles) and the vehicle frame (Chassis).
Make sure that the resistance between metallic parts of the components to the vehicle frame is lower than 10 Ohm (< 10 Ohm).
Connect moving or insulated vehicle parts such as axles electrically conductive with the frame.
- Prevent potential differences between the truck and the trailer.
Make sure that an electrically conductive connection is made via the coupling (king pin, fifth wheel, claws with pins), even with no cable connection.
- Use electrically conductive bolted connections when fastening the ECUs to the vehicle frame.
- Use only cable conforming to WABCO specifications or original WABCO cable.
- Run the cable in metallic casing if at all possible (e. g. inside the U-beam) or behind metallic and grounded protective plating, to minimise the influence of electro-magnetic fields.
- Avoid the use of plastic materials if they can cause electrostatic charging.

Note during repair and welding work on the vehicle:

- Disconnect the battery - if installed in the vehicle.
- Disconnect cable connections to devices and components and protect the plugs and connections from contamination and humidity.
- Always connect the grounding electrode directly with the metal next to the welding position when welding, to prevent magnetic fields and current flow via the cable or components.
Make sure that current is well conducted by removing paint or rust.
- Prevent heat influences on devices and cabling when welding.

1.3 Information and Disclaimer

 Read the information in this document carefully. Note especially the information on your safety.

We assume no liability for the correctness, completeness or actuality of the information in this document. All technical information, descriptions and images are applicable for the day of printing this document or respective supplements. We retain the right to any changes as a result of continuous further development.

The content of this document provides no guarantees nor warranted characteristics nor can it be construed as such. Claims in regard to information, recommendations or consultation cannot be derived from the provision thereof. Liability for damages is strictly excluded, as long as there has been no respective intention or gross negligence on our part or any forced legal provisions in opposition.

Text and graphics are subjected to our utilisation rights, copying or distribution in any form require our approval.

Any brand markings, even if not indicated as such, are subject to the rules of the labelling rights. If legal disputes arise from the utilisation of the information in this document, these are exclusively to be handled under the regulations of national law.

If any clauses of this declaration should not or no longer apply to the applicable legal regulations, the validity of the remaining clauses will remain valid.

2 Introduction

This document is directed toward vehicle manufacturers and workshops.

The equipment for trailers is subject to continual changes, which are either caused by improving technology or more legal requirements.

Spring chamber cylinders have become mandatory in trucks and will secure a parked trailer or even the entire train from rolling in case of a complete pressure-loss in the braking system. An additional mechanical parking brake with cables is not required.

Disc brakes are becoming ever more popular in wheel brakes. In comparison with drum brakes, they are easier to maintain and are not as subject to fading, diminishing braking performance over long downgrades.

ABS is required legally in most regions and is an equipment standard now.

Trailer EBS is another addition to traffic safety. Braking is shortened by the electronic transfer of the braking request. ABS and the RSS safety system are integrated. Additional devices for adapting the brake pressure to the load status are not required.

Air suspension is implemented in almost all utility vehicles nowadays. Not only the cargo but the streets too are preserved. In addition, a constant driving level and the adjustability to various ramp heights also speak for the air suspension.

Ramp heights can be learned and moved to with the push of a button with trailer ECAS. In addition, a multitude of lift axle circuits and special functions are possible.

With the Trailer EBS E, the complexity of the trailer control is increased again. This device includes the complete brake system with an ECAS system. The control of other components of the truck can also be handled.

Further information



Other documents can be obtained via the Internet at www.wabco-auto.com by entering an index work or the document number in the online product catalogue INFORM.

Publication title	Index word
Trailer brochure for the Middle-East and Africa	Trailer
TEBS E system description	TEBS E
TEBS C/D system description	TEBS
VCS II Installation notes	VCS
VCS II System description	VCS
External ECAS for truck – System description	ECAS
Pipe Couplings Catalogue	Fittings
General Repair and Test Information	Repair manual
LSV Testing equipment 435 008 000 0	LSV
Basic symbols, valves, cylinders, etc.	Symbol

3 General Information

Before choosing the right trailer system, a few general points must be considered:

WABCO recommends a brake calculation for every type of trailer braking system.

The brake systems in this document do not take the special conditions of the trailer such as trailer dimensions, axle types, wheel brake type, tyre type, etc. into account. Based on the brake calculations, it may be possible to determine whether the braking system is suitable for the applications involved.

For a correct brake calculation, it is important that the "Technical vehicle data" application form is filled out. The application form can be located at the end of this chapter. More information and support can be obtained through your WABCO partner.

Trailer braking system with automatic load-dependent brake force controller (LSV) must be set up before the installation.

The LSVs in trailers are universal valves. "Universal" does not mean Plug&Play, it means that the LSV can be used for different types of trailers.

The LSV must be set before installation in the brake system, see chapter 5.25 "Automatic load-dependent load sensing valve (LSV) 475 71.", page 109 (Tools, Parameter definition, Setting, LSV data plate) and documentation "LSV test equipment 435 008 000 0", see chapter 2 "Introduction", page 8.

The setting parameters must be calculated.

There are several ways to determine the parameters for the SLV setting, such as for example:

- Calculation with "nomographs"
- Calculation with "LSV calculation software"
- Calculation with "Trailer brake calculation" - this service can be requested from WABCO

In order to do this, WABCO requires a completed application form for the brake calculation, which you can find at the end of the chapter.

In accordance with legal requirements, the vehicle must be marked with the required information regarding the LSV testing. The respective signs can be obtained through WABCO for this, see chapter 5.25 "Automatic load-dependent load sensing valve (LSV) 475 71.", page 109. More information and support can be obtained through your WABCO partner.

A levelling valve, which must be set, is located in the air suspension system of the trailer.

The levelling valve 464 006 100 0 in the air suspension system has a lever. The optimal suspension conditions are defined with the lever length. The height limitation can also be defined, see chapter 5.20 "Levelling valve 464 006", page 91.

More information and support can be obtained through your WABCO partner.







The lift control valve may have to be set before the installation for air suspension systems on trailers with lift axle control valve 463 084 000 0.

The lift axle control valve (LACV) in trailers is a universal valve. It can be used for various lift axle control requirements. The lift axle is lowered manually with the LACV. Lifting the lift axle is done automatically. The LACV is factory-set so that it raises the axle with a bellows pressure of approximately 4 bar.

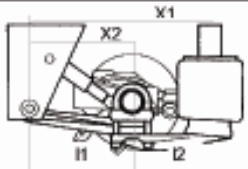
If necessary that the lift axle be raised at another operating position, this can be configured, see chapter 5.16 "Lift axle control valve 463 084", page 75. More information and support can be obtained through your WABCO partner.

Technical vehicle data for the brake calculation for trailers

WABCO		technical vehicle data for the brake calculation of trailers				1/2	
vehicle manufacturer:			type:				
approval as per:		EG / ECE <input type="checkbox"/>	other <input type="checkbox"/>	max. speed <input type="text"/>			
		designations		laden		unladen	
centre-axle trailer							
		maximum mass	P	kg			
		drawbar load	P _{st}	kg			
		axleload axle 1	P ₁	kg			
		axleload axle 2	P ₂	kg			
		axleload axle 3	P ₃	kg			
full trailer							
		maximum mass	P	kg			
		axleload axle 1	P ₁	kg			
		axleload axle 2	P ₂	kg			
		axleload axle 3	P ₃	kg			
		centre of gravity-height	h	mm			
		exist wheel base	E _R	mm			
		range of wheel base	E _R	mm			
semitrailer							
		maximum mass	min. P	kg			
			max. P	kg			
		axleload axle 1	P ₁	kg			
		axleload axle 2	P ₂	kg			
		axleload axle 3	P ₃	kg			
		centre of gravity-height	h	mm			
		exist wheel base	E _R	mm			
		range of wheel base	E _R	mm			
		axle:			1	2	3
		brake chamber: numb./type	K ₀₂				
		possible lever lengths	l _{BH}	mm			
		drum/disk radius	r _{Bt}	mm			
		C* or brakefactor					
		mechanical efficiency	η	%			
		cam radius	r _{Bn}	mm			
		dynamic tyre radius or tyre type	min. exist max.	r _{dyn}	mm		
threshold torque	M _{kl}	Nm					
axle manufact.:		type:		test report number:			
brake size:		With "standard axes", only the manufacturer and the test report number necessary!					
WABCO-brake diagram-no.:		<i>Axle bogie see page 2!</i>					
self steering axle: <input type="checkbox"/>	spring brake: <input type="checkbox"/>	ABS VCS: <input type="checkbox"/>	EBS: <input type="checkbox"/>				

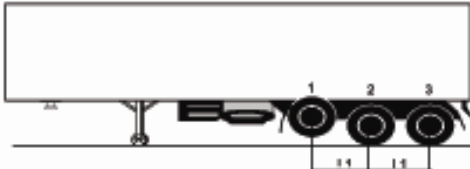
WABCO		technical vehicle data for the brake calculation of trailers		22	
axle bogie	manufacturer:	type:			
air suspension 		distance I1 / I2 [mm]:	/		
		or distance X1 / X2 [mm]:	/		
		bag diameter [mm]:			
		drawing-no.:			
leaf spring bogie (with dyn. compensation)					
					<input type="checkbox"/>
leaf spring bogie (without dyn. compensation)					
					<input type="checkbox"/>
balance beam bogie		individual axles mechanical			
					<input type="checkbox"/>
<i>In case of another axle suspension, please add bogie drawing !</i>					
bag pressure [bar]:		laden / unladen		spring deflection [mm]:	
front axle:	<input type="text"/>	<input type="text"/>	<input type="text"/>	front axle: <input type="text"/>	
rear axle(s):	<input type="text"/>	<input type="text"/>	<input type="text"/>	rear axle(s): <input type="text"/>	
semitrailer with lift axle/s					
<i>In combination with EBS, data not required !</i>					
axle	<input type="text"/>	1	2	3	
which axle/s shall be lifted [x]:	<input type="text"/>	<input type="text"/>	<input type="text"/>	<input type="text"/>	
wheel base I1 [mm]:	<input type="text"/>	<input type="text"/>			
bag pressure laden [bar]:	<input type="text"/>	<input type="text"/>			
bag pressure unladen (with axle/s lifted) [bar]:	<input type="text"/>	<input type="text"/>	<input type="text"/>	<input type="text"/>	
bag pressure unladen (all axle/s on bottom) [bar]:	<input type="text"/>	<input type="text"/>			
axle load unladen (with axle/s lifted) [kg]:	<input type="text"/>	<input type="text"/>	<input type="text"/>	<input type="text"/>	
axle load unladen (all axle/s on bottom) [kg]:	<input type="text"/>	<input type="text"/>			
remarks:					
company:		street:			
name:		city:			
telephone:		telefax:			
e-mail:					

4 Diagram



Diagram

Open the WABCO website www.wabco-auto.com.
Click on *Product Catalogue INFORM* => *Product number*.
Enter the diagram number into the search field.
Click the *Start* button.

4.1 VCS II brake diagram

Axle(s)	ABS system	Number	Tristop	Solenoid control valve	Anti-Compound Relay Valve	PREV	LSV	Additional trailer	12 V	Comment
Semitrailer										
1	2S/2M	841 700 990 0								
1	2S/2M	841 700 991 0	x							
1	2S/2M	841 700 992 0		x						
1	2S/2M	841 700 993 0	x	x						
1	2S/2M	841 700 994 0	x			x				Without LSV
1	2S/2M	841 700 995 0		x						Hydraulic brake
1	2S/2M	841 700 996 0	x		x				x	
1	2S/2M	841 700 997 0	x						x	
2	4S/2M	841 700 980 0								
2	4S/2M	841 700 981 0	x							
2	4S/3M	841 700 982 0								
2	4S/3M	841 700 983 0	x							
2	4S/2M	841 700 984 0	x		x		x			
2	2S/2M	841 700 986 0	x							
2	2S/2M	841 700 987 0	x							Tristop only one axle
2	4S/3M	841 700 988 0	x							LSV: Control line
2	2S/2M	841 700 989 0	x		x					
2	4S/2M	841 701 120 0	x						x	
2	2S/2M 4S/2M	841 701 121 0	x			x				
2	4S/3M	841 701 122 0	x		x					
3	4S/3M	841 700 970 0								
3	4S/3M	841 700 971 0	x							
3	4S/2M	841 700 972 0								
3	4S/2M	841 700 973 0	x							
3	2S/2M	841 700 974 0								
3	4S/2M	841 700 975 0	x		x	x				
3	4S/2M	841 700 976 0	x		x					

Axle(s)	ABS system	Number	Tristop	Solenoid control valve	Anti-Compound Relay Valve	PREV	LSV	Additional trailer	12 V	Comment
3	2S/2M	841 700 977 0	x		x					Select Low + Relay valve
3	4S/3M	841 700 978 0	x		x	x				Spring brake actuator Axles 1+2
3	2S/2M	841 700 979 0	x		x			x		
3	2S/2M 4S/2M	841 701 060 0	x				x			
3	2S/2M 4S/2M	841 701 062 0	x		x		x			
3	2S/2M	841 701 064 0								
3	4S/3M	841 701 068 0	x		x			x		VB aggregate
3	2S/2M 4S/2M	841 701 069 0	x		x					Expandable
3	4S/3M	841 701 150 0	x		x					Expandable
3	2S/2M 4S/2M	841 701 151 0	x						x	
3	4S/3M	841 701 152 0	x		x					
3	4S/3M	841 701 153 0	x							
3	4S/3M	841 701 154 0	x							Separate electronics
4	4S/3M	841 701 000 0								
4	4S/3M	841 701 001 0	x							
4	4S/3M	841 701 002 0	x		x					Additional relay valve in front
4	4S/3M	841 701 003 0								Separate relay valve for axle 3
4	4S/3M	841 701 004 0	x							Separate relay valve for axle 3
4	4S/3M	841 701 005 0	x							
4	4S/3M	841 701 081 0	x		x				x	
5	4S/3M	841 701 080 0	x		x					
6	4S/3M	841 701 090 0	x		x					Separate electronics
Central axle trailer										
1	2S/2M	841 601 100 0								
1	2S/2M	841 601 101 0		x						
1	2S/2M	841 601 102 0						x		
1	2S/2M	841 601 103 0	x							
2	4S/2M	841 601 110 0								
2	2S/2M 4S/2M	841 601 111 0	x							
2	4S/3M	841 601 112 0		x						
2	4S/3M	841 601 113 0								
2	2S/2M	841 601 114 0		x						VB aggregate / diagonal
2	2S/2M	841 601 115 0								
2	2S/2M	841 601 116 0		x						Without LSV

Axle(s)	ABS system	Number	Tristop	Solenoid control valve	Anti-Compound Relay Valve	PREV	LSV	Additional trailer	12 V	Comment
2	2S/2M 4S/2M	841 601 117 0	x		x					
2	4S/3M	841 601 118 0	x			x				
2	4S/3M	841 601 170 0	x							One Tristop rear
2	4S/3M	841 601 171 0	x							
2	2S/2M	841 601 172 0	x	x						Pressure Reducing Valve
2	4S/3M	841 601 173 0	x	x						VB aggregate
2	2S/2M	841 601 174 0		x						LSV: Control line
2	4S/3M	841 601 175 0								LSV: Control line
2	2S/2M 4S/2M	841 601 176 0		x						Hydraulic brake
2	2S/2M 4S/2M	841 601 177 0								LSV: Control line
2	2S/2M	841 601 178 0	x							
2	2S/2M 4S/2M	841 601 179 0	x							LSV: Control line
2	4S/3M	841 601 260 0	x		x			x		VB aggregate
2	4S/3M	841 601 261 0	x							VB aggregate / LSV: Control valve
2	2S/2M	841 601 262 0	x							Pressure Reducing Valve
3	2S/2M 4S/2M	841 601 250 0	x							Tristop only one axle
3	2S/2M 4S/2M	841 601 251 0								
Draw-bar trailer										
2	4S/3M	841 601 120 0								
2	4S/3M	841 601 121 0	x							
2	4S/3M	841 601 122 0		x						
2	4S/3M	841 601 123 0	x	x						
2	4S/3M	841 601 124 0	x							Front axle modulator!
2	4S/3M	841 601 125 0	x		x	x				Front axle modulator!
2	4S/3M	841 601 126 0	x			x				
2	4S/3M	841 601 127 0	x							One Tristop rear
2	4S/3M	841 601 128 0	x		x					
2	4S/3M	841 601 129 0								Hydraulic brake
2	4S/3M	841 601 180 0	x		x					Without "Add-on" in front
2	4S/3M	841 601 181 0								Separate electronics
2	4S/3M	841 601 182 0	x		x					Modulator in front
2	4S/3M	841 601 183 0	x		x	x				
2	4S/3M	841 601 184 0	x							Separate electronics
3	4S/3M	841 601 130 0								

Axle(s)	ABS system	Number	Tristop	Solenoid control valve	Anti-Compound Relay Valve	PREV	LSV	Additional trailer	12 V	Comment
3	4S/3M	841 601 131 0	x							
3	4S/3M	841 601 132 0	x		x					
3	4S/3M	841 601 133 0	x		x					Without "Add-on" in front
4	4S/3M	841 601 140 0	x		x					
4	4S/3M	841 601 141 0	x		x					Modulator in front
4	4S/3M	841 601 142 0	x		x					3 axles rear / last axle Select Low
4	4S/3M	841 601 143 0	x		x				x	
4	4S/3M	841 601 144 0	x		x					2 ABS systems
4	4S/2M 4S/2M	841 601 145 0								Additional relay valve rear

4.2 Trailer EBS E brake diagram

Axle(s)	ABS system	Number	Tristop	Overload protection valve	PEM	TCE	Mechanical suspension	Additional trailer	PREV	Modulator Front axle	Comment
Semitrailer											
1	2S/2M	841 701 180 0 (in the annex)	x	x					x		
1	2S/2M	841 701 181 0	x					x	x		Dolly / hydraulic suspension
1	2S/2M	841 701 182 0	x		x				x		
2	2S/2M 4S/2M	841 701 190 0	x	x					x		
2	4S/3M	841 701 191 0	x	x					x		
2	2S/2M	841 701 192 0	x	x							
2	2S/2M 4S/2M	841 701 193 0	x		x				x		
2	4S/3M	841 701 195 0	x		x				x		Only one axle Tristop!
2	4S/3M	841 701 196 0	x		x				x		
3	4S/3M	841 701 050 0	x						x		
3	4S/3M	841 701 055 0	x								CAN-Repeater
3	4S/3M	841 701 057 0	x	x					x		CAN-Repeater + Select Low
3	4S/3M	841 701 058 0	x	x					x		CAN-Repeater
3	2S/2M 4S/2M	841 701 100 0	x								
3	2S/2M 4S/2M	841 701 101 0	x						x		
3	2S/2M	841 701 102 0	x						x		Select Low
3	4S/2M+1M	841 701 103 0	x						x		
3	2S/2M 4S/2M	841 701 104 0	x			x			x		
3	4S/2M+1M	841 701 105 0	x				x		x		
3	2S/2M 4S/2M	841 701 106 0 (in the annex)	x	x					x		
3	2S/2M	841 701 107 0	x	x					x		Select Low
3	2S/2M	841 701 108 0	x		x				x		Select Low (Relay valve)
3	2S/2M	841 701 109 0	x						x		Select Low (Relay valve)
3	2S/2M 4S/2M	841 701 110 0 (in the annex)	x		x				x		
3	4S/3M	841 701 111 0	x		x				x		
3	2S/2M	841 701 112 0	x	x					x		Select Low (Relay valve)
3	4S/3M	841 701 113 0 (in the annex)	x	x					x		
3	4S/3M	841 701 114 0	x	x							
3	4S/2M	841 701 115 0	x		x				x		Internal loader

Axle(s)	ABS system	Number	Tristop	Overload protection valve	PEM	TCE	Mechanical suspension	Additional trailer	PREV	Modulator Front axle	Comment
3	2S/2M 4S/2M	841 701 116 0	x	x				x	x		
3	2S/2M	841 701 117 0	x		x				x		Select Low
3	4S/2M+1M	841 701 118 0	x		x				x		
3	4S/3M	841 701 119 0	x		x				x		EBS relay on axle 1
3	4S/2M+1M	841 701 221 0	x		x				x		
3	2S/2M 4S/2M	841 701 222 0									
3	4S/2M+1M	841 701 223 0	x	x					x		
3	4S/3M	841 701 224 0									
3	2S/2M 4S/2M	841 701 227 0	x		x				x		Immobilizer
3	2S/2M 4S/2M	841 701 228 0	x		x			x	x		
3	2S/2M 4S/2M	841 701 229 0	x		x			x	x		
4	4S/3M	841 701 050 0	x						x		
4	4S/3M	841 701 051 0	x	x							Select Low 1. axle
4	4S/3M	841 701 052 0	x		x				x		Select Low 1st axle (Relay valve)
4	4S/3M	841 701 055 0 (in the annex)	x								CAN-Repeater
7	4S/3M	841 701 210 0	x						x		Hydraulic suspension
Central axle trailer											
1	2S/2M	841 601 290 0	x		x				x		
2	2S/2M 4S/2M	841 601 280 0 (in the annex)	x		x				x		
2	4S/3M	841 601 281 0	x	x			x		x		VB aggregate
2	2S/2M 4S/2M	841 601 282 0 (in the annex)	x	x					x		
2	2S/2M 4S/2M	841 601 283 0	x					x	x		Dolly
2	2S/2M 4S/2M	841 601 284 0	x						x		Both axles with Tristop
2	2S/2M 4S/2M	841 601 285 0	x					x	x		Dolly / hydraulic suspension
2	2S/2M 4S/2M	841 601 286 0	x	x				x	x		Dolly
2	2S/2M 4S/2M	841 601 287 0 (in the annex)	x					x	x		Dolly CAN-Router
3	4S/2M 2S/2M	841 601 300 0	x		x				x		
3	4S/2M 2S/2M	841 601 301 0	x	x					x		
Drawbar trailer											
2	4S/3M	841 601 220 0	x						x	x	
2	4S/3M	841 601 223 0 (in the annex)	x	x					x	x	

Axle(s)	ABS system	Number	Tristop	Overload protection valve	PEM	TCE	Mechanical suspension	Additional trailer	PREV	Modulator Front axle	Comment
2	4S/3M	841 601 224 0 (in the annex)	x		x				x		
2	4S/3M	841 601 225 0	x		x		x		x		
2	4S/3M	841 601 226 0									
2	4S/3M	841 601 227 0	x	x			x		x	x	
2	4S/3M	841 601 228 0								x	
2	4S/3M	841 601 229 0	x	x					x		
2	4S/3M	841 601 230 0	x						x		
2	4S/3M	841 601 341 0	x		x				x	x	
3	4S/3M	841 601 230 0	x						x		
3	4S/3M	841 601 231 0	x	x					x		
3	4S/3M	841 601 232 0 (in the annex)	x		x				x		
3	4S/3M	841 601 233 0	x	x							
3	4S/3M	841 601 235 0	x		x		x				
4	4S/3M	841 601 240 0	x	x					x		
4	4S/3M	841 601 241 0	x	x					x	x	
4	4S/3M	841 601 242 0	x						x		
4	4S/3M	841 601 243 0	x				x			x	
4	4S/3M	841 601 244 0	x		x				x		
4	2x 4S/2M	841 601 245 0	x								CAN-Router 2x 4S/2M
4	4S/3M	841 601 246 0	x		x					x	

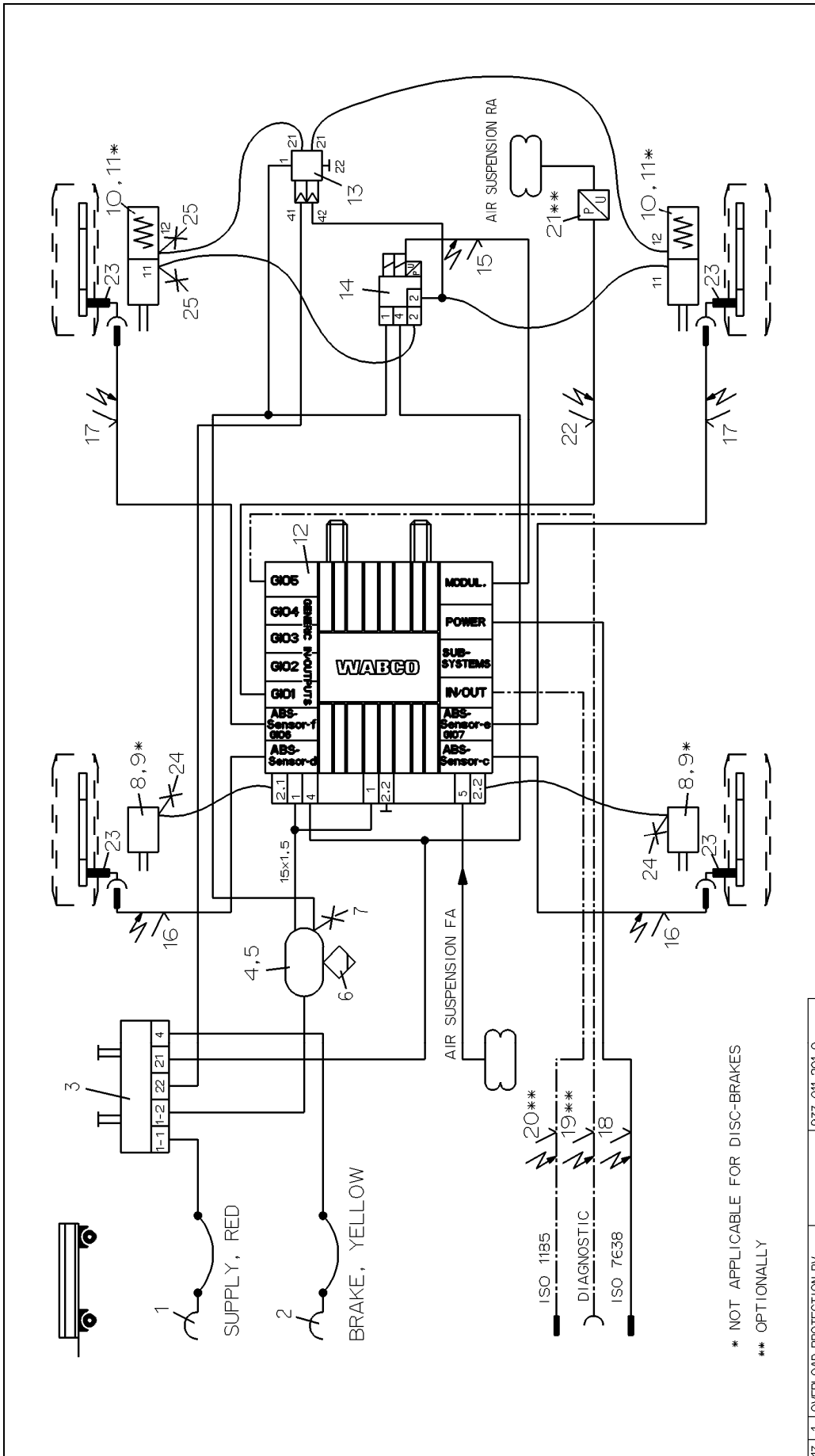

Pos. Pos.	Denomination	Product Identification No.	Pos. Pos.	Denomination	Product Identification No.
13	1 OVERLOAD-PROTECTION-RV	973 011 201 0	25	2 TEST CONNECTION	463 703 036 0
12	1 TRAILER- MODULATOR	480 102 ... 0	24	2 TEST CONNECTION	463 703 120 0
11	2 KIT	423 903 532 2	23	4 ABS-SENSOR	441 ... 0
10	2 TRISTOP BRAKE ACTUATOR	925 ... 0	22	1 CABLE TO PRESSURE SENSOR	449 872 ... 0
9	2 KIT	423 ... 2	21	1 PRESSURE SENSOR	441 040 013 0
8	2 BRAKE CHAMBER	423 ... 0	20	1 24IN-CABLE	449 349 ... 0
7	1 TEST CONNECTION	463 703 ... 0	19	1 DIAGNOSTIC CABLE	449 611 ... 0
6	1 DRAIN VALVE	934 300 001 0	18	1 SUPPLY (POWER) CABLE	449 273 ... 0
5	1 HOSE CLAMP	451 999 ... 2	17	2 EXTENSION CABLE FOR SENSOR	449 723 ... 0
4	1 AIR RESERVOIR	950 ... 0	16	2 EXTENSION CABLE FOR SENSOR	449 723 ... 0
3	1 PARK-RELEASE-EMERGENCY VALVE	971 002 9... 0	15	1 CABLE TO EBS-RV	449 429 ... 0
2	1 COUPLING HEAD W. INT. LINE FILTER	952 201 ... 0	14	1 EBS-RELAY VALVE	480 207 0... 0
1	1 COUPLING HEAD W. INT. LINE FILTER	952 201 ... 0			

* NOT APPLICABLE FOR DISC-BRAKES
 ** OPTIONALLY

WABCO
 TRAILER - EBS E
 FOR 2-AXLES-TRAILER
 4S/3M, AIR SUSPENSION WITH RSS

Copyright WABCO®
 Date: 2008-09-16
 Drawn: BURMESTER
 Checked: BURMESTER
 Expert: BURMESTER
 Scale: -

Material No.: 841 601 223 0
 Doc.Code: 002
 Language: EN
 Date of first issue: 2008-09-16
 Sheet: 1/1

Revisión: -
 Techn. Resp.: 4990
 Pro/E

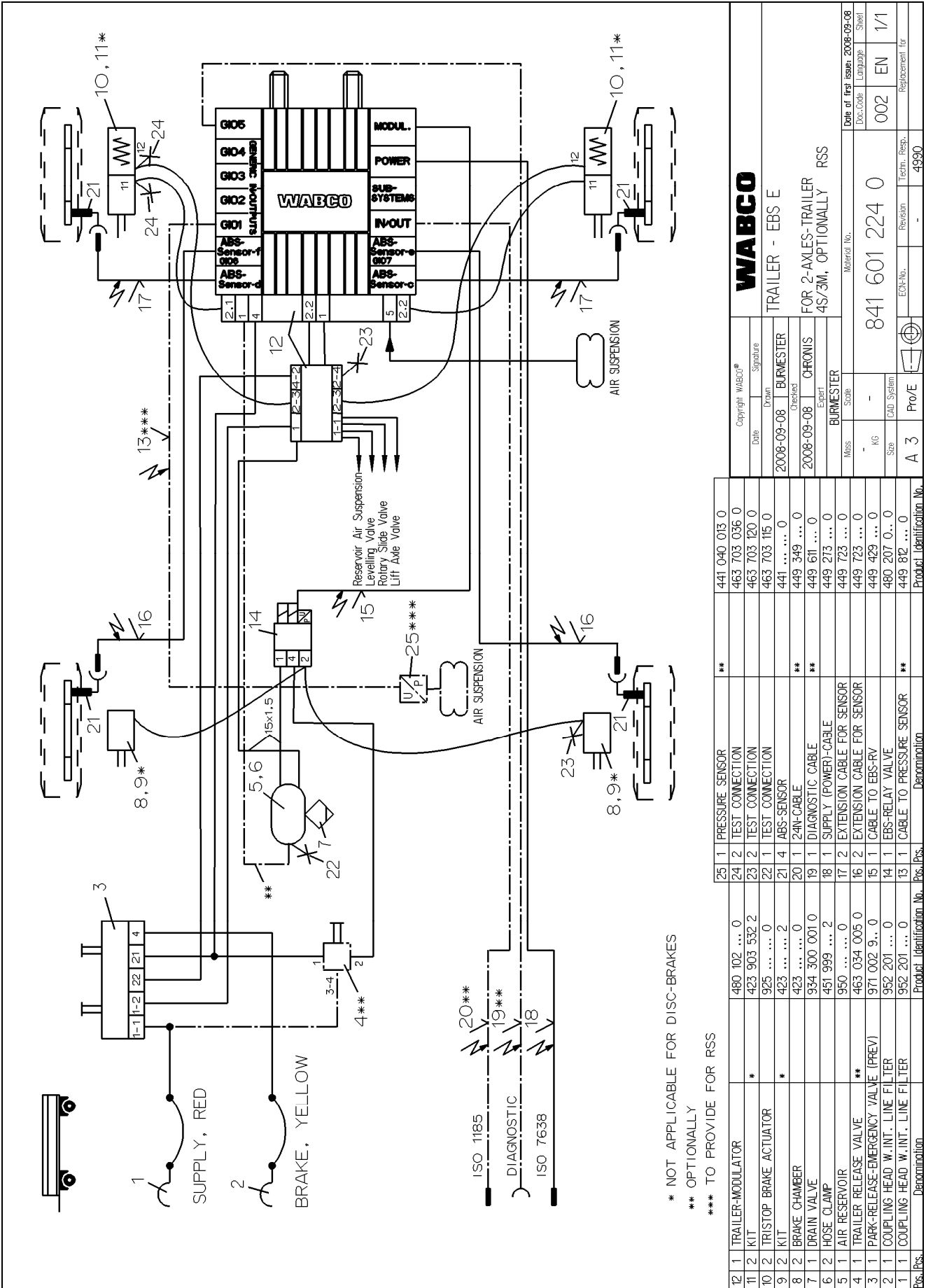

* NOT APPLICABLE FOR DISC-BRAKES

** OPTIONALLY

*** TO PROVIDE FOR RSS

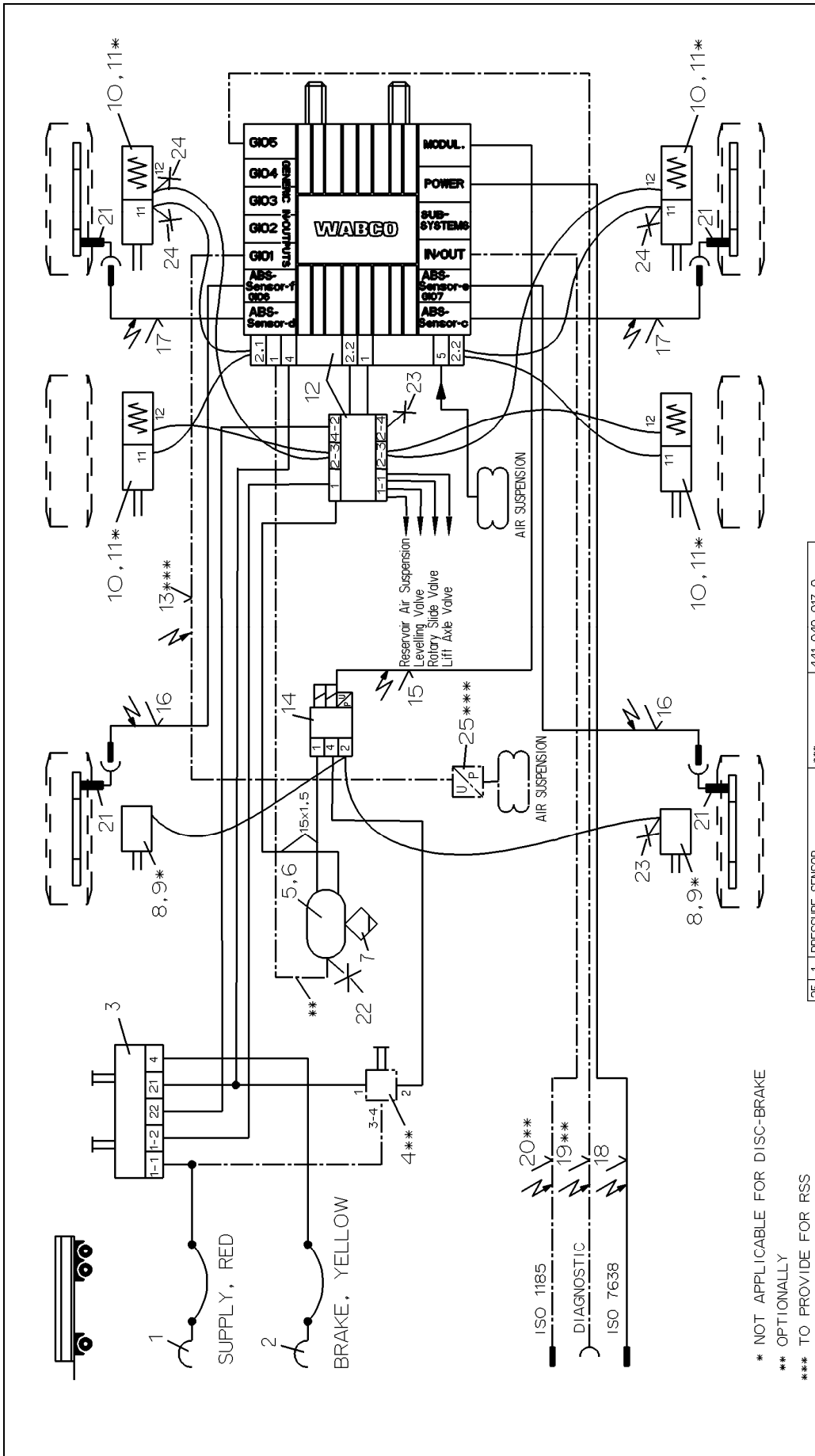

* NOT APPLICABLE FOR DISC-BRAKE

** OPTIONAL

*** TO PROVIDE FOR RSS

12	1	TRAILER-MODULATOR	441 040 013 0	Product Identification No.
11	4	KIT	463 703 036 0	
10	4	TRIPSTOP BRAKE ACTUATOR	463 703 120 0	
9	2	KIT	463 703 115 0	
8	2	BRAKE CHAMBER	441 ... 0	
7	1	DRAIN VALVE	449 349 ... 0	
6	2	HOSE CLAMP	449 611 ... 0	
5	1	AIR RESERVOIR	449 723 ... 0	
4	1	TRAILER RELEASE VALVE	449 723 ... 0	
3	1	PARK-RELEASE-EMERGENCY VALVE (PREV)	449 429 ... 0	
2	1	COUPLING HEAD W. INT. LINE FILTER	480 207 0... 0	
1	1	COUPLING HEAD W. INT. LINE FILTER	449 812 ... 0	
Pos. Pcs.		Denomination		
25	1	PRESSURE SENSOR	441 040 013 0	
24	3	TEST CONNECTION	463 703 036 0	
23	2	TEST CONNECTION	463 703 120 0	
22	1	TEST CONNECTION	463 703 115 0	
21	4	ABS-SENSOR	441 ... 0	
20	1	24N-CABLE	449 349 ... 0	
19	1	DIAGNOSTIC CABLE	449 611 ... 0	
18	1	SUPPLY (POWER) CABLE	449 723 ... 0	
17	2	EXTENSION CABLE FOR SENSOR	449 723 ... 0	
16	2	EXTENSION CABLE FOR SENSOR	449 723 ... 0	
15	1	CABLE TO EBS-RV	449 429 ... 0	
14	1	EBS-RELAY VALVE	480 207 0... 0	
13	1	CABLE TO PRESSURE SENSOR	449 812 ... 0	
Pos. Pcs.		Denomination		

WABCO

TRAILER - EBS E
FOR 3-AXLES-TRAILER
4S/3M, OPTIONALLY RSS

Date	Signature
2008-09-09	BURMESTER
2008-09-09	CHRONIS
Scale	BURMESTER
Mass	-
KG	-
Size	-
CAD System	-
Pro/E	A 3
ECH-No.	119783
Revision	A
Techn. Resp.	4990
Doc.No.	841 601 232 0
Doc.Code	002
Language	EN
Sheet	1/1
Date of first issue	2008-09-09

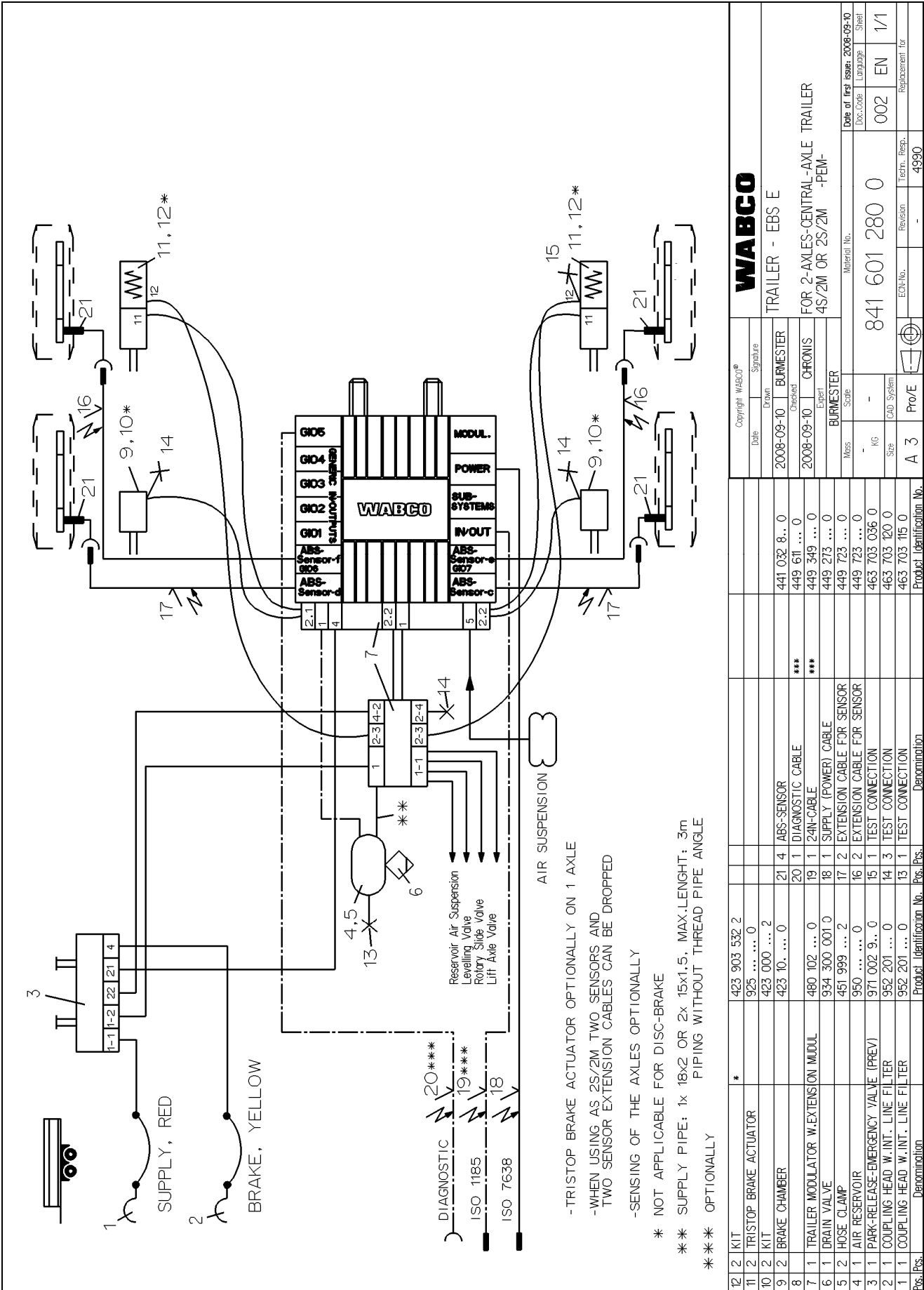

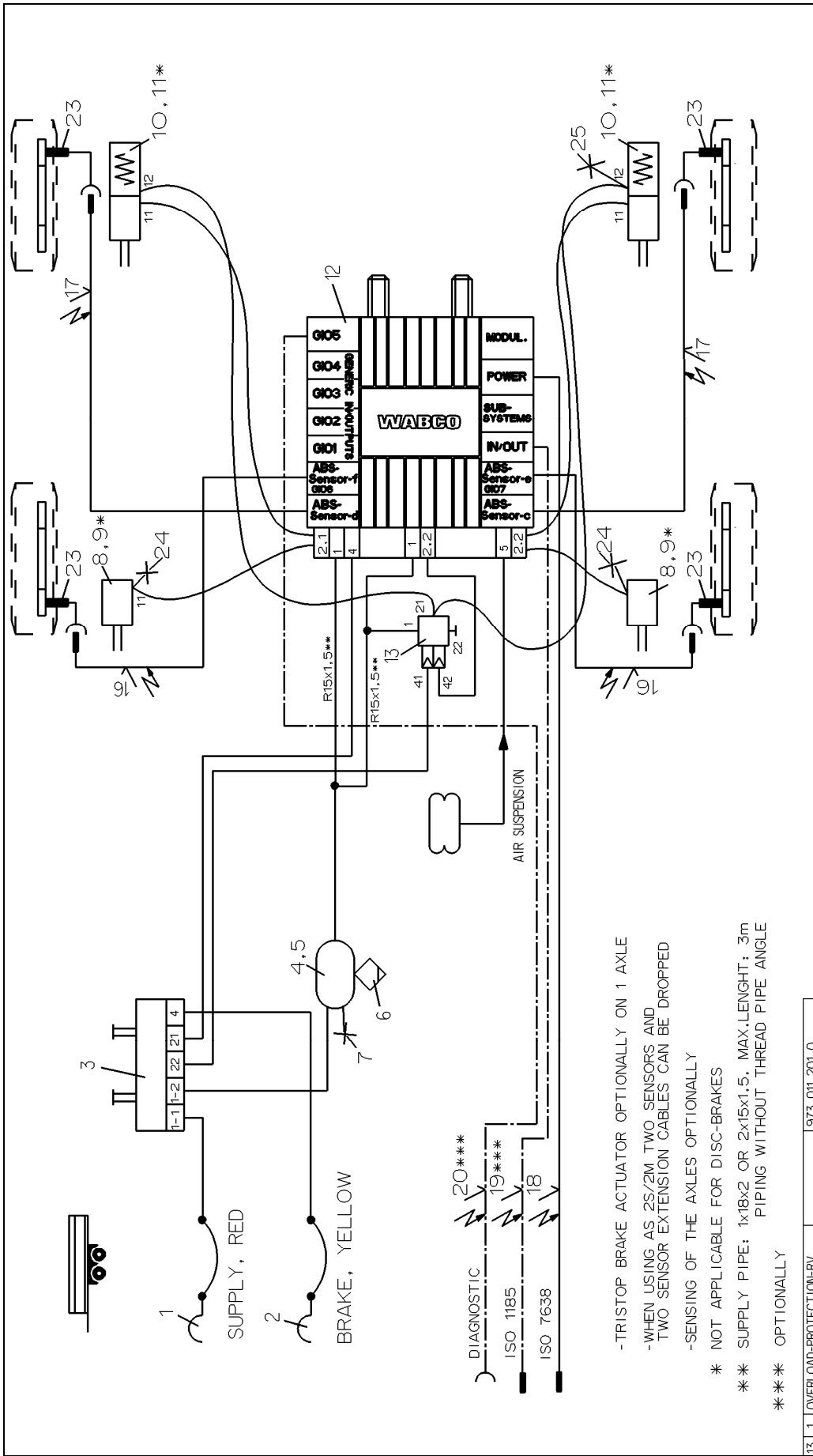

-TRISTOP BRAKE ACTUATOR OPTIONALLY ON 1 AXLE
 -WHEN USING AS 2S/2M, TWO SENSORS AND TWO SENSOR EXTENSION CABLES CAN BE DROPPED
 -SENSING OF THE AXLES OPTIONALLY
 * NOT APPLICABLE FOR DISC-BRAKES
 ** SUPPLY PIPE: 1x18x2 OR 2x15x1.5, MAX.LENGTH: 3m
 PIPING WITHOUT THREAD PIPE ANGLE
 *** OPTIONALLY

13	1	OVERLOAD-PROTECTION-RV	973 011 201 0				
12	1	TRAILER-MODULATOR	480 102 ... 0	25	1	TEST CONNECTION	463 703 036 0
11	2	KIT	423 903 532 2	24	1	TEST CONNECTION	463 703 120 0
10	2	TRISTOP BRAKE ACTUATOR	925 0	23	4	ABS-SENSOR	441 0
9	2	KIT	423 2	22			
8	2	BRAKE CHAMBER	423 0	21			
7	1	TEST CONNECTION	463 703 115 0	20	1	DIAGNOSTIC CABLE	449 611 ... 0
6	1	DRAIN VALVE	934 300 001 0	19	1	24N-CABLE	449 349 ... 0
5	2	HOSE CLAMP	451 999 ... 2	18	1	SUPPLY (POWER) CABLE	449 273 ... 0
4	1	AIR RESERVOIR	950 0	17	2	EXTENSION CABLE FOR SENSOR	449 723 ... 0
3	1	PARK-RELEASE-EMERGENCY VALVE (PREV)	971 002 9... 0	16	2	EXTENSION CABLE FOR SENSOR	449 723 ... 0
2	1	COUPLING HEAD W.INT. LINE FILTER	952 201 ... 0	15			
1	1	COUPLING HEAD W.INT. LINE FILTER	952 201 ... 0	14			

Copyright	WABCO®	
Date		Signature
Drawn	BURMESTER	
Checked	BURMESTER	
Expert	CARONIS	
Scale	BURMESTER	
Mass		
Size	- KG	
CAD System		
Pro/E	A 3	
Material No.	841 601 282 0	
Doc.Code	002	
Language	EN	
Sheet	1/1	
Revision		
Techn. Resp.	4990	
Product Identification No.	Denomination	

WABCO
 TRAILER - EBS E
 FOR 2-AXLES-CENTRAL-AXLE TRAILER
 2S/2M OR 4S/2M, OPTIONALLY RSS

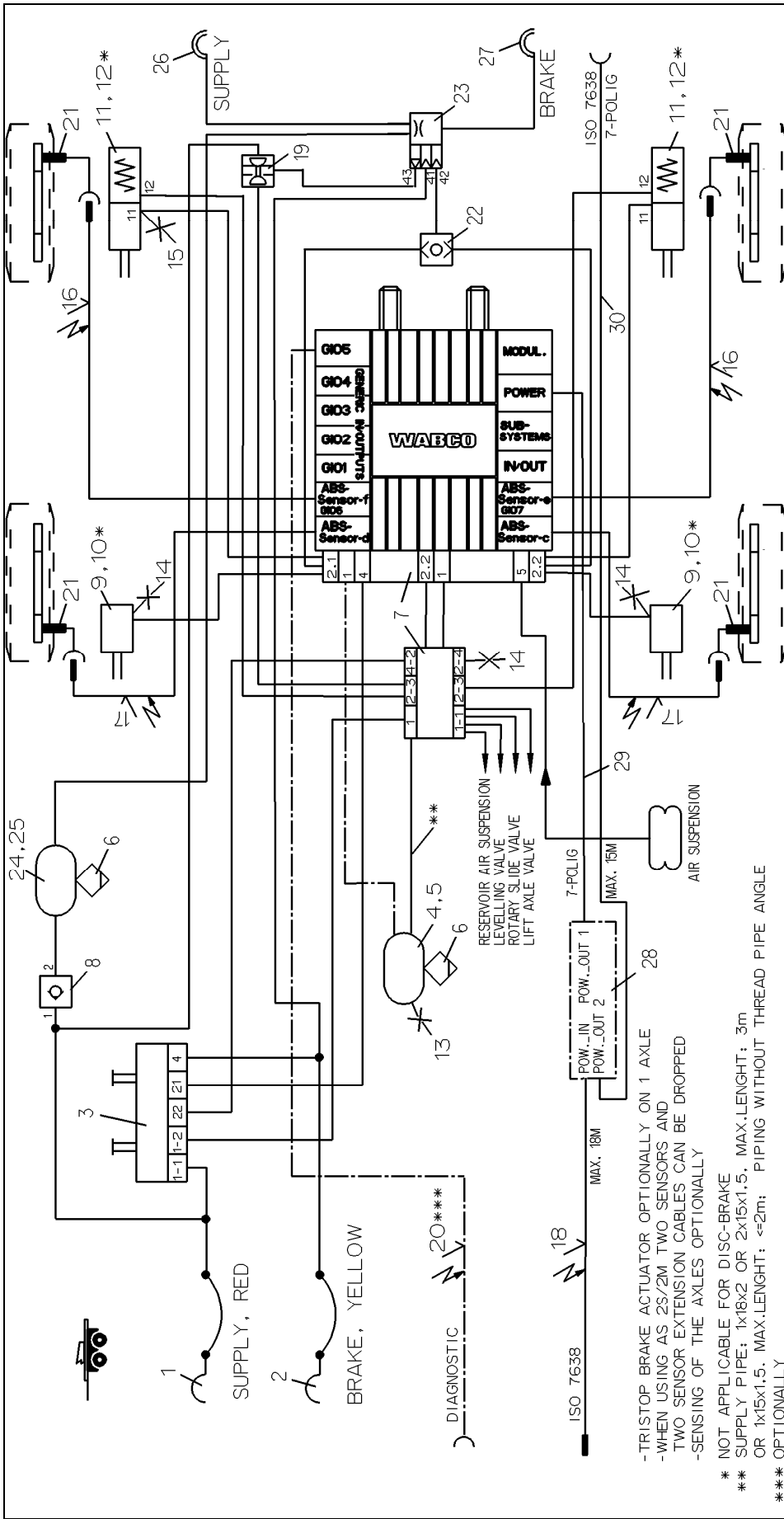

- TRIPSTOP BRAKE ACTUATOR OPTIONALLY ON 1 AXLE
 - WHEN USING AS 2S/2M TWO SENSORS AND TWO SENSOR EXTENSION CABLES CAN BE DROPPED
 - SENSING OF THE AXLES OPTIONALLY

** NOT APPLICABLE FOR DISC-BRAKE
 ** SUPPLY PIPE: 1x18x2 OR 2x15x1.5, MAX.LENGTH: 3m
 OR 1x15x1.5, MAX.LENGTH: <=2m; PIPING WITHOUT THREAD PIPE ANGLE
 *** OPTIONALLY

15	1	TEST CONNECTION	463 703 036 0	30	1	SUPPLY (POWER) CABLE	449 135 ... 0
14	3	TEST CONNECTION	463 703 120 0	29	1	SUPPLY (POWER) CABLE	449 347 ... 0
13	1	TEST CONNECTION	463 703 115 0	28	1	CAN-ROUTER	446 122 050 0/052 0
12	2	KIT	423 903 532 2	27	1	COUPLING HEAD AUTOM. BRAKE	952 200 222 0
11	2	TRIPSTOP BRAKE ACTUATOR	925 0	26	1	COUPLING HEAD AUTOM. SUPPLY	952 200 221 0
10	2	KIT	423 000 ... 0	25	2	HOSE CLAMP	451 999 ... 2
9	2	BRAKE CHAMBER	423 10 ... 0	24	1	AIR RESERVOIR	950 0
8	1	CHECK VALVE	434 014 000 0	23	1	TRAILER CONTROL VALVE	973 0
7	1	TRAILER-MODULATOR W.EXTENSION MODUL	480 102 ... 0	22	2	SELECT HIGH VALVE	434 708 ... 0
6	2	DRAIN VALVE	934 300 001 0	21	4	ABS-SENSOR	441 032 8 ... 0
5	2	HOSE CLAMP	451 999 ... 2	20	1	DIAGNOSTIC CABLE	449 611 ... 0
4	1	AIR RESERVOIR	950 0	19	1	DOUBLE CUT-OFF VALVE	434 500 003 0
3	1	PARK-RELEASE-EMERG.-VALVE (PREV)	971 002 9 ... 0	18	1	SUPPLY (POWER) CABLE	449 133 ... 0
2	1	COUPLING HEAD W. INT. LINE FILTER	952 201 ... 0	17	2	EXTENSION CABLE FOR SENSOR	449 723 ... 0
1	1	COUPLING HEAD W. INT. LINE FILTER	952 201 ... 0	16	2	EXTENSION CABLE FOR SENSOR	449 723 ... 0

WABCO

TRAILER - EBS E
 WITH CAN-ROUTER
 4S/2M OR 2S/2M
 -DOLLY-

Copyright Wabco®
 Date: 2009-04-15
 Drawn: BURMESTER
 Checked: LANGOWICZ
 Date of issue: 2009-04-15
 Doc. Code: 841 601 287 0
 Language: EN
 Sheet: 1/1

Material No.: 841 601 287 0
 Revision: A
 Techn. Resp.: 4990
 Replacement for: 123576

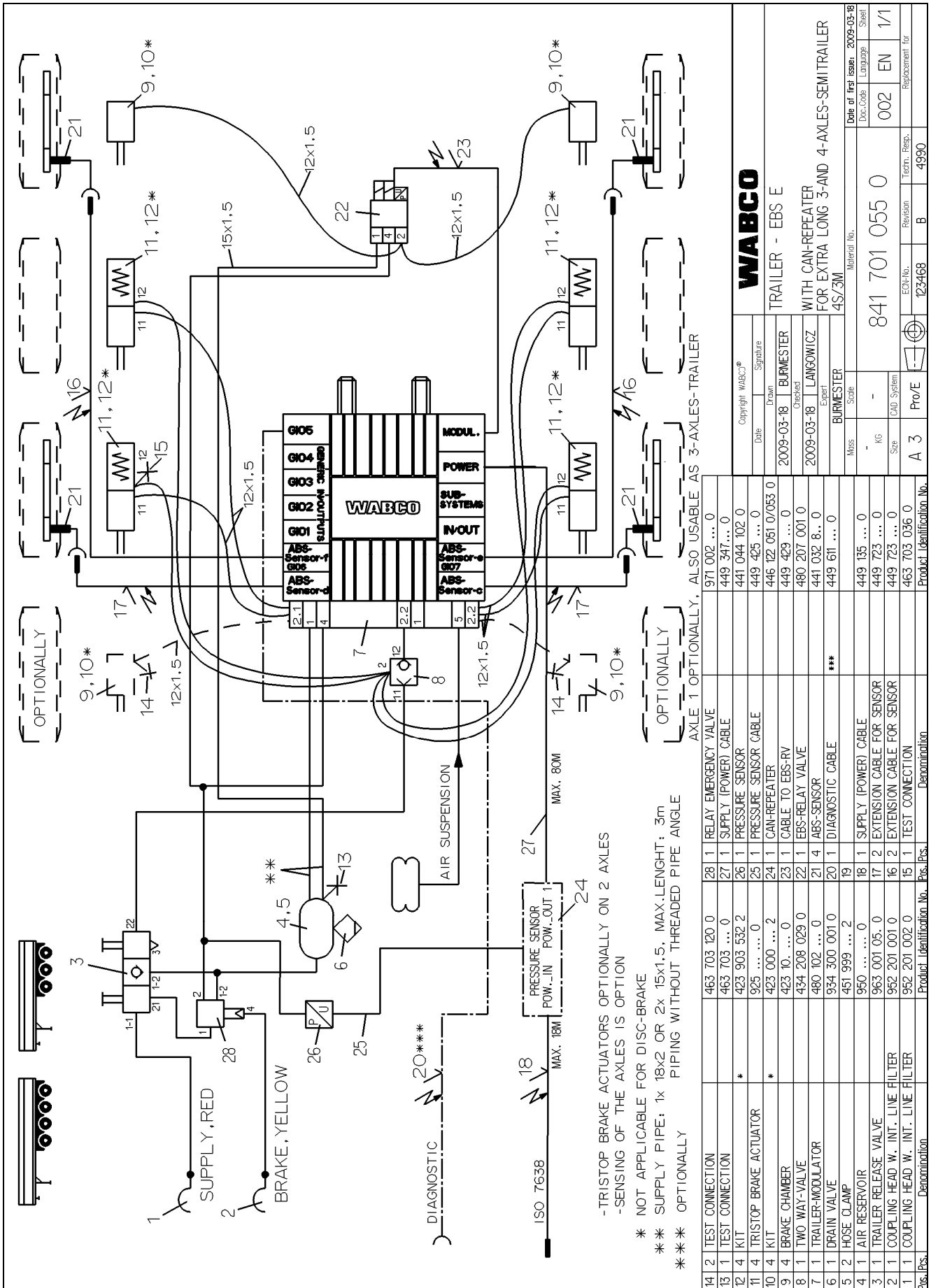

WABCO

TRAILER - EBS E
WITH CAN-REPEATER
FOR EXTRA LONG 3-AND 4-AXLES-SEMITRAILER
4S/3M

Copyright WABCO®	Signature
Date	2009-03-18
Drawn	BURMESTER
Checked	BURMESTER
Expert	BURMESTER
Scale	
Material No.	841 701 055 0
Doc. Code	002
Language	EN
Sheet	1/1
Revision	
Techn. Resp.	
Replacement for	
Material No.	123468
Revision	B
Part No.	4990

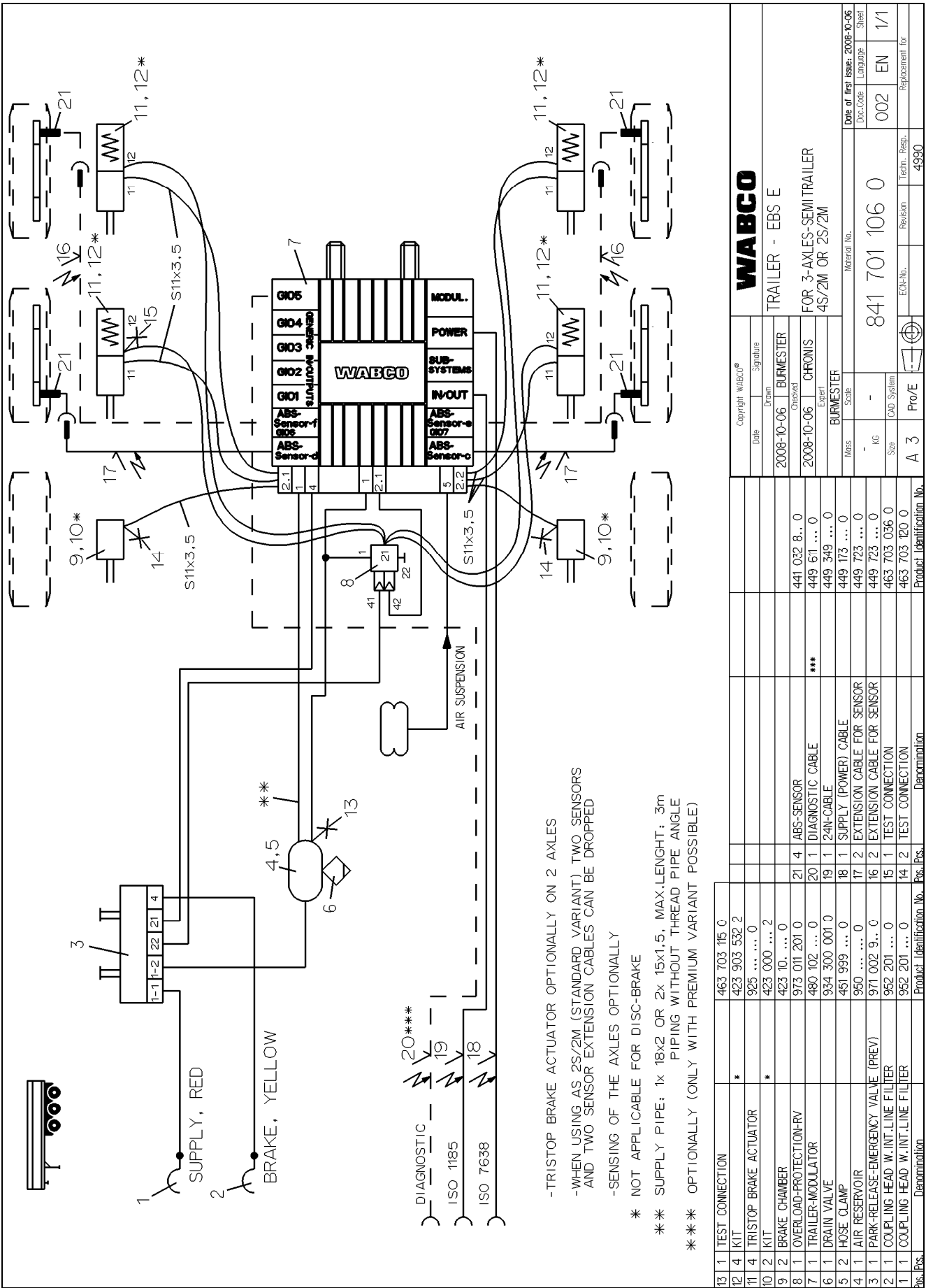

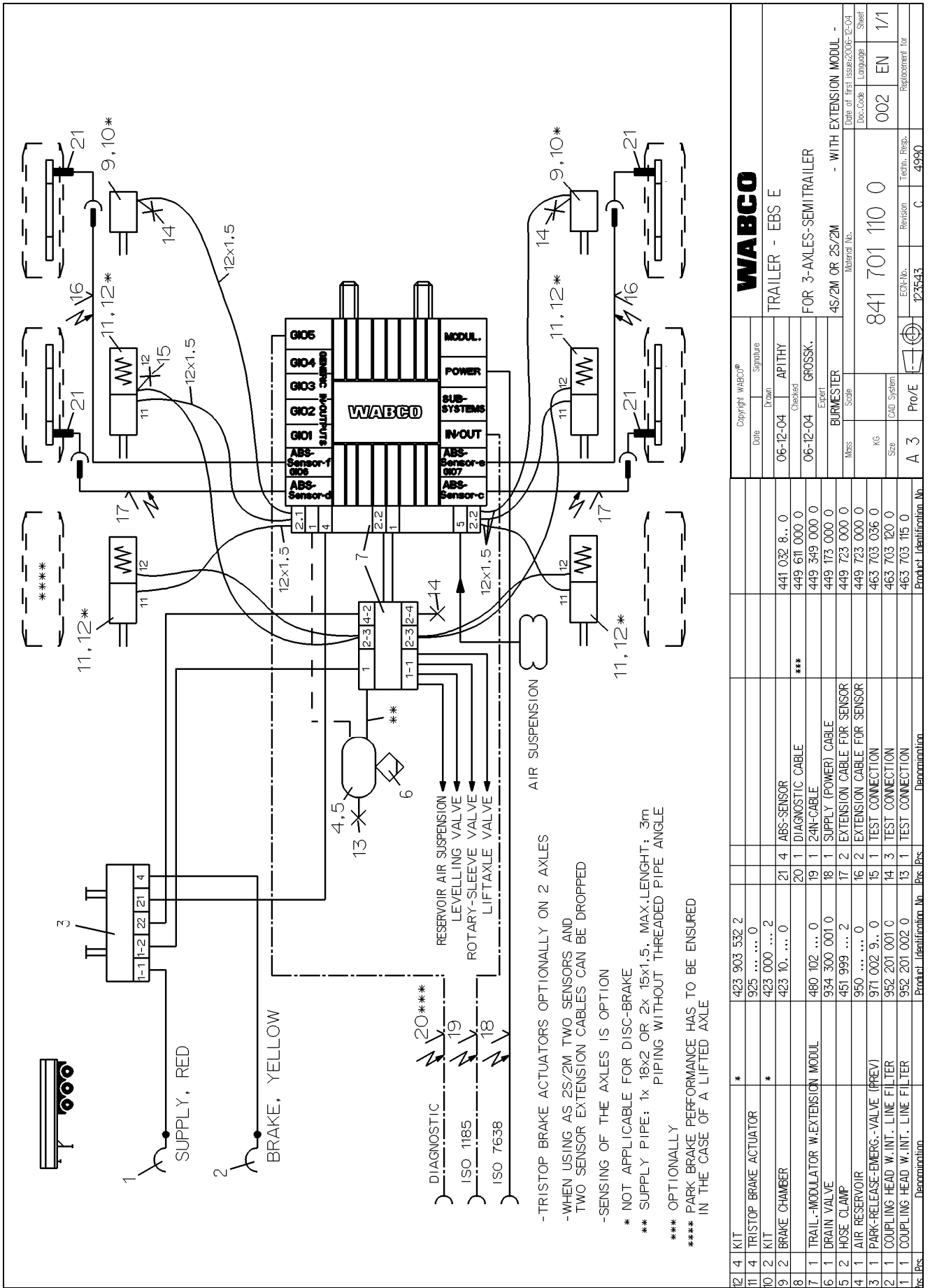

Copyright: WABCO®		Date	Signature
Date		06-12-04	APITHY
Checked		06-12-04	GROSSK.
Expert		BURMESTER	
Scale		4S/2M OR 2S/2M - WITH EXTENSION MODUL -	
Material No.		841 701 110 0	
Mass		449 723 000 0	
KG		463 703 036 0	
Size		463 703 120 0	
CAD System		A 3	
Pro/E		C	
Revision		Tech. Resp.	
EOL-No.		4990	
Doc.Code		002	
Language		EN	
Sheet		1/1	

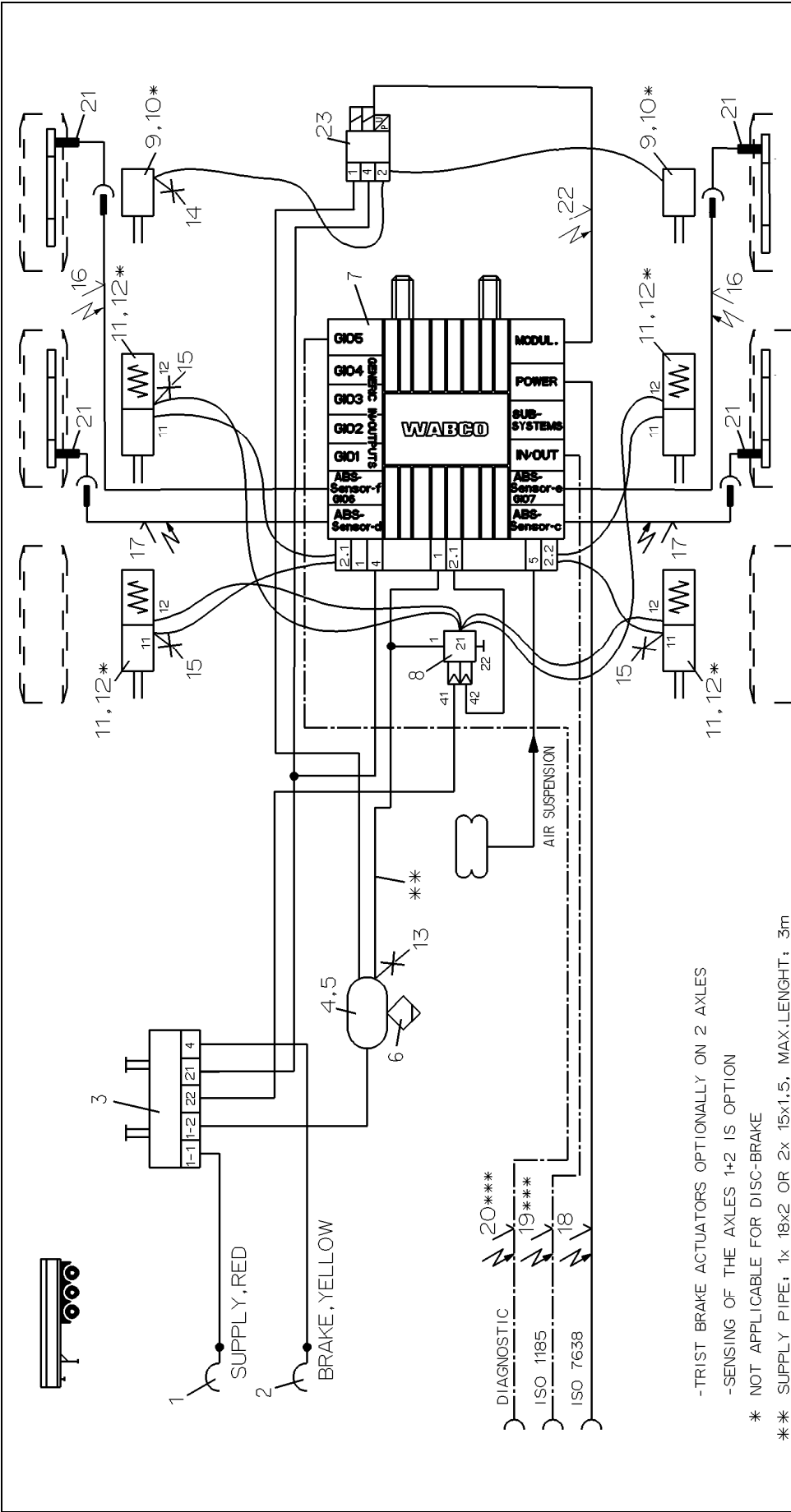

-TRIST BRAKE ACTUATORS OPTIONALLY ON 2 AXLES
 -SENSING OF THE AXLES 1+2 IS OPTION
 * NOT APPLICABLE FOR DISC-BRAKE
 ** SUPPLY PIPE: 1x 18x2 OR 2x 15x1.5, MAX. LENGTH: 3m
 PIPING WITHOUT THREADED PIPE ANGLE
 *** OPTIONALLY

Copyright WABCO®			Signature	
Date	Date			
2008-03-10	BURMESTER			
2008-03-10	CHRONIS			
Material No.		Date of first issue: 2008-05-10		
841 701 113 0		Doc. Code		Language
		002		EN
		Revision		Replacement for
A 3		4990		
<p>WABCO TRAILER - EBS E FOR 3-AXLES-SEMI TRAILER 4S/3M</p>				
12 4 KIT	423 903 532 2		480 207 0.. 0	
11 4 TRISTOP BRAKE ACTUATOR	929 ... 0	23 1 EBS-RELAY VALVE	449 429 ... 0	
10 2 KIT	423 000 ... 2	22 1 CABLE TO EBS-RV	973 011 ... 0	
9 2 BRAKE CHAMBER	423 10... 0	21 1 RELAY VALVE	449 611 ... 0	
8 1 OVERLOAD-PROTECT.-RV	973 011 201 0	20 1 DIAGNOSTIC CABLE	449 349 ... 0	***
7 1 TRAILER-MODULATOR	480 102 ... 0	19 1 24N-CABLE	449 173 ... 0	***
6 1 DRAIN VALVE	934 300 001 0	18 1 POWER CABLE	449 723 ... 0	
5 1 HOSE CLAMP	451 999 ... 0	17 2 EXTENSION CABLE FOR SENSOR	441 032 8.. 0	
4 1 AIR RESERVOIR	950 ... 0	16 2 ABS-SENSOR	463 703 036 0	
3 1 PARK-RELEASE-EMERG.-VALVE (PREV)	971 002 9.. 0	15 3 TEST CONNECTION	463 703 120 0	
2 1 COUPLING HEAD W. INT.LINE FILTER	952 201 ... 0	14 1 TEST CONNECTION	463 703 115 0	
1 1 COUPLING HEAD W. INT.LINE FILTER	952 201 ... 0	13 1 TEST CONNECTION		
Denomination		Product Identification No. / Pos. / Pos. / Denomination		

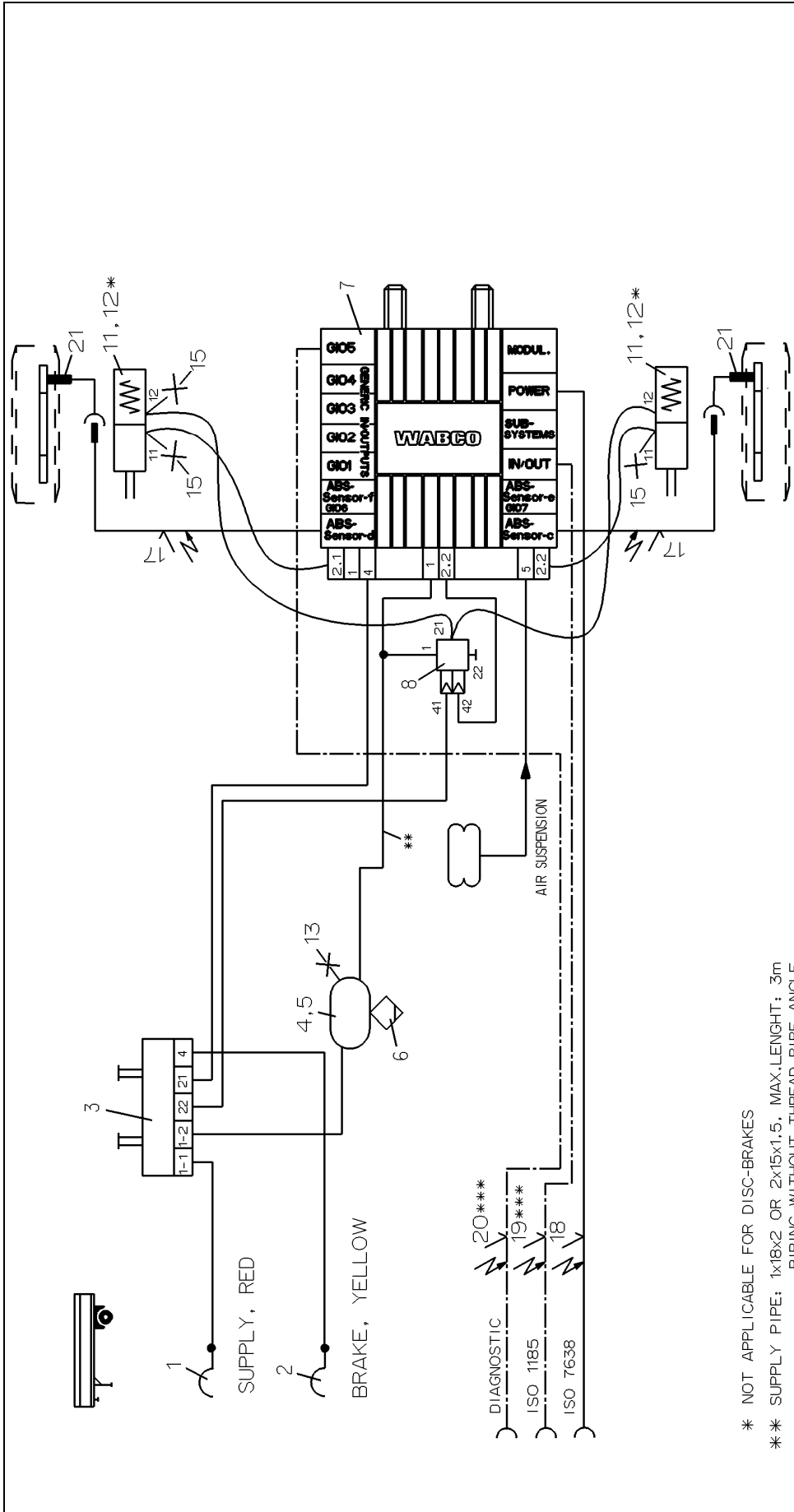

- * NOT APPLICABLE FOR DISC-BRAKES
- ** SUPPLY PIPE: 1x18x2 OR 2x15x1.5, MAX.LENGTH: 3m
PIPING WITHOUT THREAD PIPE ANGLE
- *** OPTIONALLY

13	1	TEST CONNECTION	463 703 115 0	25						
12	2	KIT	423 903 532 2	24						
11	2	TRISTOP BRAKE ACTUATOR	925 0	23						
10				22						
9				21	2	ABS-SENSOR	441 032 8... 0			
8	1	OVERLOAD-PROTECTION-RV	973 011 201 0	20	1	DIAGNOSTIC CABLE	449 611 ... 0			
7	1	TRAILER-MODULATOR	480 102 ... 0	19	1	24N-CABLE	449 349 ... 0			
6	1	DRAIN VALVE	934 300 001 0	18	1	SUPPLY (POWER) CABLE	449 173 ... 0			
5	2	HOSE CLAMP	451 999 ... 2	17	2	EXTENSION CABLE FOR SENSOR	449 723 ... 0			
4	1	LUFTBEHALTER	950 0	16			463 703 036 0			
3	1	PARK-RELEASE-EMERGENCY VALVE (PREV)	971 002 9... 0	15	3	TEST CONNECTION				
2	1	COUPLING HEAD W.INT. LINE FILTER	952 201 ... 0	14						
1	1	COUPLING HEAD W.INT. LINE FILTER	952 201 ... 0							
Pos./Pos.		Denomination	Product Identification No.	Pos./Pos.		Denomination	Product Identification No.			

WABCO

TRAILER - EBS E
FOR 1-AXLE-SEMI TRAILER
2S/2M

Copyright WABCO®	Signature	
Date	Drawn	
2008-10-06	BURMESTER	
Checked		
2008-10-06	CHRONIS	
Excerpt		
BURMESTER		
Mass	Scale	
-	-	
Size	CAD System	
A 3	Pro/E	
ECH-No.	Revision	Techn. Resp.
		4990
Material No.	841 701 180 0	
Date of first issue: 2006-10-06	Doc.Code	Language
	002	EN
	1/1	Sheet
		Replacement for

4.3 Lift axle circuits

Number	Single circuit	Dual circuit	Electr. actuated	Mechan. actuated	Fully automatic control	Traction help (TH)	Lowering function	Rotary slide valve	TASC	Height limiting levelling valve	2 LACV	ELM	Residual pressure	Comments
ABS														
841 801 447 0		x	x											
841 801 448 0		x		x										
841 801 449 0		x			x									
841 801 472 0		x			x		x							
841 801 473 0		x	x			x								
841 801 476 0		x		x							x			2 LACV
841 801 479 0		x			x		x							
841 801 520 0		x			x		x							
841 801 522 0		x			x	x								
841 801 524 0		x			x		x	x		x				5-axle trailer, 2 LACV
841 801 525 0		x			x	x								StVZO § 41
841 801 529 0		x			x	x	x							
841 801 572 0		x			x		x							
841 801 573 0		x			x	x	x	x		x				
841 801 574 0		x			x		x	x		x				
841 801 576 0		x	x			x					x			2 LACV
841 801 600 0					x		x							
841 801 927 0	x		x					x	x	x				
841 801 928 0									x					
EBS														
841 801 791 0		x	x		x							x		with ELM
841 801 792 0	x		x		x							x		with ELM
841 801 920 0		x	x		x			x	x	x				
841 801 921 0		x	x		x	x	x	x	x	x				Switch for lift axle controller in trailer
841 801 922 0		x	x		x	x	x	x	x	x				Switch for lift axle controller in truck
841 801 923 0	x		x		x	x	x	x		x			x	Switch for lift axle controller in truck
841 801 924 0	x		x		x			x	x	x				

Number	Single circuit	Dual circuit	Electr. actuated	Mechan. actuated	Fully automatic control	Traction help (TH)	Lowering function	Rotary slide valve	TASC	Height limiting levelling valve	2 LACV	ELM	Residual pressure	Comments
841 801 925 0	x		x		x	x	x	x	x	x				Switch for lift axle controller in truck
841 801 926 0	x		x		x	x	x	x	x	x				Switch for lift axle controller in truck
841 801 929 0	x		x		x	x	x	x		x	x		x	Switch for lift axle controller in truck
841 802 070 0	x		x		x	x	x	x		x	x			Switch for lift axle controller in truck
841 802 071 0	x		x		x	x	x	x			x			Switch for lift axle controller in trailer and truck
841 802 072 0	x		x		x	x	x	x		x				Switch for lift axle controller in truck
841 802 073 0	x		x		x	x	x	x			x			Switch for lift axle controller in trailer and truck
841 802 074 0	x		x		x	x	x	x	x					Switch for lift axle controller in truck
841 802 075 0	x		x		x	x	x	x	x					Switch for lift axle controller in trailer
841 802 076 0	x		x		x	x	x	x						Switch for lift axle controller in trailer and truck
841 802 077 0	x		x		x	x	x	x	x				x	Switch for lift axle controller in truck
841 802 078 0	x		x		x	x	x	x			x		x	Switch for lift axle controller in truck
841 802 079 0	x		x		x	x	x	x			x			Switch for lift axle controller in truck
841 802 138 0		x	x		x	x	x	x	x		x			with 2 single-circuit LACV

4.4 Air suspension

Axles	In connection with brake system	Number	Distance sensor	Lift axle(s)	Comment	ECAS ECU
Semitrailer						
1-2-3 axle	VCS	841 801 722 0	1	1		446 055 065 0
2-3 axle	VCS	841 801 723 0	1	1		446 055 065 0
2-3 axle	VCS	841 801 724 0	2 right/left	1		446 055 065 0
2-3 axle	VCS	841 801 725 0	2	1		446 055 065 0
3 axles	VCS	841 801 726 0	1	2 separate		446 055 065 0
2-3 axle	VCS	841 801 727 0	1		1 Trailing-Axle Control	446 055 065 0
2-3 axle	VCS	841 801 730 0	1	1	Train transport	446 055 065 0
2-3 axle	VCS	841 801 731 0	1		Traction help	446 055 065 0
1-3 axle	VCS	841 801 732 0	1		Tyre impression compensation	446 055 065 0
3 axles	VCS	841 801 733 0	2	2 separate		446 055 065 0
3 axles	VCS	841 801 734 0	2 right/left	2		446 055 065 0
2-3 axle	VCS	841 801 735 0	2			446 055 065 0
3 axles	VCS	841 801 736 0	1	2 separate		446 055 065 0
2-3 axle	VCS	841 801 737 0	2 right/left			446 055 065 0
3 axles	VCS	841 801 780 0	1	2 parallel		446 055 065 0
2-3 axle	VCS	841 801 782 0	2		Tyre impression compensation	446 055 065 0
1-2-3 axle	VCS II	841 802 022 0	1			446 055 065 0
2-3 axle	VCS II	841 802 023 0 (in the annex)	1	1		446 055 066 0
2-3 axle	VCS II	841 802 024 0	2 right/left	1		446 055 066 0
2-3 axle	VCS II	841 802 025 0	2	1		446 055 066 0
3 axles	VCS II	841 802 026 0	1	2 separate		446 055 066 0
2-3 axle	VCS II	841 802 027 0	1		1 Trailing-Axle Control	446 055 066 0
2-3 axle	VCS II	841 802 080 0	1	1	Train transport	446 055 066 0
2-3 axle	VCS II	841 802 081 0	1		Traction help	446 055 066 0
1-3 axle	VCS II	841 802 082 0	1		Tyre impression compensation	446 055 066 0
3 axles	VCS II	841 802 083 0	2	2 separate		446 055 066 0
3 axles	VCS II	841 802 084 0	2 right/left	2		446 055 066 0
2-3 axle	VCS II	841 802 085 0	2			446 055 066 0
3 axles	VCS II	841 802 086 0	1	2 separate		446 055 066 0
2-3 axle	VCS II	841 802 087 0	2 right/left			446 055 066 0
3 axles	VCS II	841 802 089 0	1	2 parallel		446 055 066 0
2-3 axle	VCS II	841 802 091 0	2		Tyre impression compensation	446 055 066 0
2-3-4 axle	EBS	841 801 750 0 (in the annex)	2		with front axle valve	446 055 066 0
2-3-4 axle	EBS	841 801 751 0	2		without front axle valve	446 055 066 0
1-2-3 axle	EBS	841 801 752 0	1			446 055 066 0
2-3 axle	EBS	841 801 753 0 (in the annex)	1	1		446 055 066 0
2-3 axle	EBS	841 801 754 0	2 right/left	1		446 055 066 0

Axles	In connection with brake system	Number	Distance sensor	Lift axle(s)	Comment	ECAS ECU
2-3 axle	EBS	841 801 755 0	2	1		446 055 066 0
3 axles	EBS	841 801 756 0	1	2 separate		446 055 066 0
2-3 axle	EBS	841 801 757 0	1		1 Trailing-Axle Control	446 055 066 0
2-3 axle	EBS	841 801 760 0	1	1	Train transport	446 055 066 0
2-3 axle	EBS	841 801 761 0	1		Traction help	446 055 066 0
1-3 axle	EBS	841 801 762 0	1		Tyre impression compensation	446 055 066 0
3 axles	EBS	841 801 763 0	2	2 separate		446 055 066 0
3 axles	EBS	841 801 764 0	2 right/left	2		446 055 066 0
2-3 axle	EBS	841 801 765 0	2			446 055 066 0
3 axles	EBS	841 801 766 0	1	2 separate		446 055 066 0
2-3 axle	EBS	841 801 767 0	2 right/left			446 055 066 0
3 axles	EBS	841 801 769 0	1	2 parallel		446 055 066 0
2-3 axle	EBS	841 801 821 0	2		Tyre impression compensation	446 055 066 0
3 axles	EBS	841 801 822 0	1		1. Axle: Traction help 3. Axle: Manoeuvre assistance	446 055 066 0
3 axles	EBS	841 801 823 0	1	2 separate	2. Lift axle: Manoeuvre assistance + Forced lowering	446 055 066 0
3 axles	EBS	841 801 824 0	1	1	single circuit	446 055 066 0
3 axles	EBS	841 801 825 0	1	2	single circuit	446 055 066 0
3 axles	EBS	841 801 826 0	1	2 separate		446 055 066 0
3 axles	EBS	841 801 827 0	1	1	without traction help	446 055 066 0
2-3 axle	EBS E	841 802 150 0 (in the annex)		1	Conventional air suspension Levelling valve	
3 axles	EBS E	841 802 017 0	1		Battery operation	446 055 066 0
Draw-bar trailer						
2 axles	with/without ABS/EBS	841 801 434 0 (in the annex)			Levelling valve	
3 axles	with/without ABS/EBS	841 801 435 0 (in the annex)			Levelling valve with height limitation and rotary slide valve	
1-3 axle	with/without ABS/EBS	841 801 436 0 (in the annex)			Levelling valve	
1-3 axle	with/without ABS/EBS	841 801 437 0 (in the annex)			Levelling valve with height limitation and rotary slide valve	
2-3-4 axle	VCS	841 801 720 0	2		with front axle valve	446 055 065 0
2-3-4 axle	VCS	841 801 721 0	2		without valve throttle	446 055 065 0
3-4 axle	VCS	841 801 728 0	3		with front axle valve	446 055 065 0
3-4 axle	VCS	841 801 729 0	3	1	with front axle valve	446 055 065 0
3-4 axle	VCS	841 801 738 0	2	1	with front axle valve	446 055 065 0
2-3 axle	VCS	841 801 781 0	2		with front axle valve, train transport	446 055 065 0
2-3-4 axle	VCS II	841 802 020 0 (in the annex)	2		with front axle valve	446 055 066 0
2-3-4 axle	VCS II	841 802 021 0	2		without valve throttle	446 055 066 0
2-3-4 axle	VCS II	841 802 028 0	3		with front axle valve	446 055 066 0
3-4 axle	VCS II	841 802 029 0	3	1	with front axle valve	446 055 066 0
3-4 axle	VCS II	841 802 088 0	2	1	with front axle valve	446 055 066 0
2-3 axle	VCS II	841 802 090 0	2		with front axle valve, train transport	446 055 066 0

Axles	In connection with brake system	Number	Distance sensor	Lift axle(s)	Comment	ECAS ECU
2-3 axle	VCS II	841 802 092 0	2		2x rear axle valve	446 055 066 0
2-3-4 axle	EBS	841 801 758 0	3		with front axle valve	446 055 066 0
3-4 axle	EBS	841 801 759 0	3	1	with front axle valve	446 055 066 0
3-4 axle	EBS	841 801 768 0	2	1	with front axle valve	446 055 066 0
2-3 axle	EBS	841 801 820 0	2		with front axle valve, train transport	446 055 066 0
2 axles	EBS E	841 802 016 0	2		with control box & unloading level switch	446 055 066 0
2 axles	EBS E	841 802 018 0	2		with control box & battery	446 055 066 0
2 axles	EBS E	841 802 019 0	2		with control box	446 055 066 0
2 axles	EBS E	841 802 242 0	2		with front axle valve, without control box, with unloading level	446 055 066 0
Connection of control box and remote control unit to ECAS						
	VCS II	841 801 785 0				
	VCS	841 801 828 0				
	EBS	841 801 829 0				

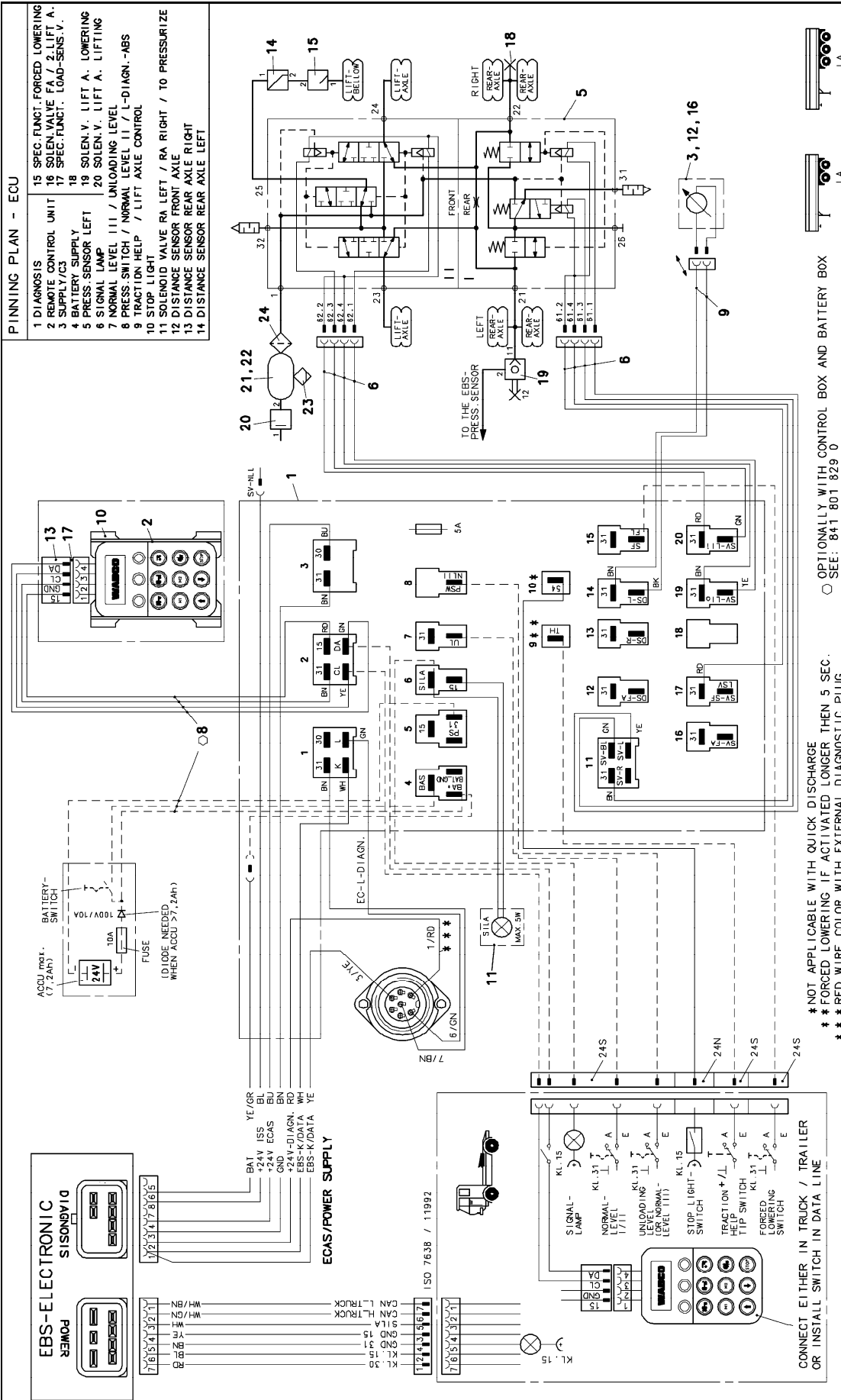

○ OPTIONALLY WITH CONTROL BOX AND BATTERY BOX
SEE: 841 801 829 0

*** NOT APPLICABLE WITH QUICK DISCHARGE
*** FORCED LOWERING IF ACTIVATED LONGER THEN 5 SEC.
*** RED WIRE COLOR WITH EXTERNAL DIAGNOSTIC PLUG

COMPONENT	DATE	DESCRIPTION	REVISION	DATE
1	06-06-23	AP 11HY	0	
2	06-06-23	STERNMANN	1	
3	06-06-23	STERNMANN	1	
4	06-06-23	STERNMANN	1	
5	06-06-23	STERNMANN	1	
6	06-06-23	STERNMANN	1	
7	06-06-23	STERNMANN	1	
8	06-06-23	STERNMANN	1	
9	06-06-23	STERNMANN	1	
10	06-06-23	STERNMANN	1	
11	06-06-23	STERNMANN	1	
12	06-06-23	STERNMANN	1	
13	06-06-23	STERNMANN	1	
14	06-06-23	STERNMANN	1	
15	06-06-23	STERNMANN	1	
16	06-06-23	STERNMANN	1	
17	06-06-23	STERNMANN	1	
18	06-06-23	STERNMANN	1	
19	06-06-23	STERNMANN	1	
20	06-06-23	STERNMANN	1	
21	06-06-23	STERNMANN	1	
22	06-06-23	STERNMANN	1	
23	06-06-23	STERNMANN	1	
24	06-06-23	STERNMANN	1	
25	06-06-23	STERNMANN	1	
26	06-06-23	STERNMANN	1	
27	06-06-23	STERNMANN	1	
28	06-06-23	STERNMANN	1	
29	06-06-23	STERNMANN	1	
30	06-06-23	STERNMANN	1	
31	06-06-23	STERNMANN	1	
32	06-06-23	STERNMANN	1	

COMPONENT	DATE	DESCRIPTION	REVISION	DATE
1	06-06-23	AP 11HY	0	
2	06-06-23	STERNMANN	1	
3	06-06-23	STERNMANN	1	
4	06-06-23	STERNMANN	1	
5	06-06-23	STERNMANN	1	
6	06-06-23	STERNMANN	1	
7	06-06-23	STERNMANN	1	
8	06-06-23	STERNMANN	1	
9	06-06-23	STERNMANN	1	
10	06-06-23	STERNMANN	1	
11	06-06-23	STERNMANN	1	
12	06-06-23	STERNMANN	1	
13	06-06-23	STERNMANN	1	
14	06-06-23	STERNMANN	1	
15	06-06-23	STERNMANN	1	
16	06-06-23	STERNMANN	1	
17	06-06-23	STERNMANN	1	
18	06-06-23	STERNMANN	1	
19	06-06-23	STERNMANN	1	
20	06-06-23	STERNMANN	1	
21	06-06-23	STERNMANN	1	
22	06-06-23	STERNMANN	1	
23	06-06-23	STERNMANN	1	
24	06-06-23	STERNMANN	1	
25	06-06-23	STERNMANN	1	
26	06-06-23	STERNMANN	1	
27	06-06-23	STERNMANN	1	
28	06-06-23	STERNMANN	1	
29	06-06-23	STERNMANN	1	
30	06-06-23	STERNMANN	1	
31	06-06-23	STERNMANN	1	
32	06-06-23	STERNMANN	1	

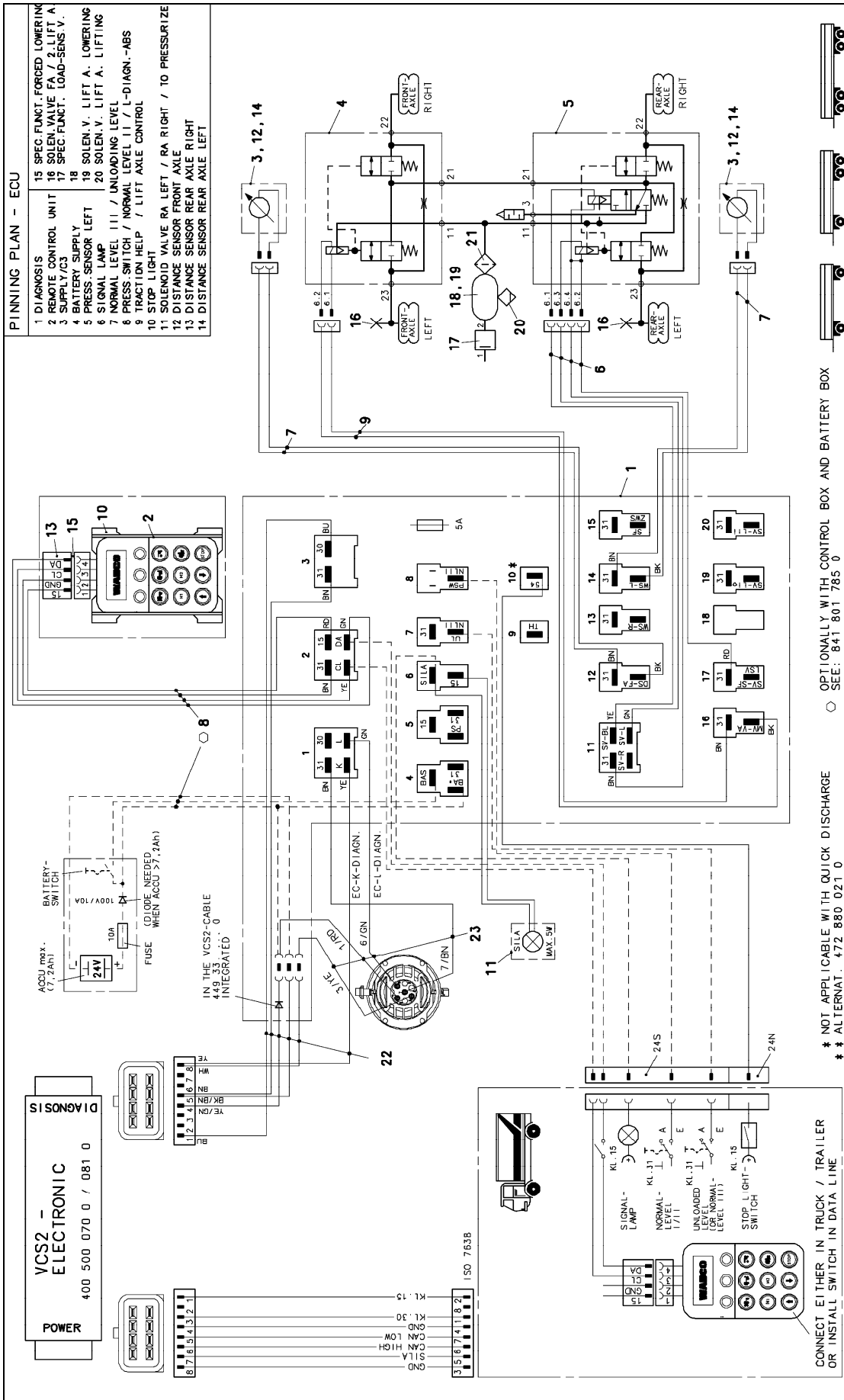

NO.	DESCRIPTION	WABCO PART NO.	ISO NO.	DATE	REVISION
1	BRACKET FOR REMOTE CONTR. CABLE (OPTION)	446 056 052 4			
2	LEVER FOR DISTANCE SENSOR	441 050 718 2			
3	SOLENOID VALVE	446 056 537 2			
4	SOLENOID VALVE	449 621 050 0			
5	SOLENOID VALVE	449 632 050 0			
6	SOLENOID VALVE	449 632 050 0			
7	SOLENOID VALVE	449 632 050 0			
8	SOLENOID VALVE	449 632 050 0			
9	SOLENOID VALVE	449 632 050 0			
10	SOLENOID VALVE	449 632 050 0			
11	SOLENOID VALVE	449 632 050 0			
12	SOLENOID VALVE	449 632 050 0			
13	SOLENOID VALVE	449 632 050 0			
14	SOLENOID VALVE	449 632 050 0			
15	SOLENOID VALVE	449 632 050 0			
16	SOLENOID VALVE	449 632 050 0			
17	SOLENOID VALVE	449 632 050 0			
18	SOLENOID VALVE	449 632 050 0			
19	SOLENOID VALVE	449 632 050 0			
20	SOLENOID VALVE	449 632 050 0			
21	SOLENOID VALVE	449 632 050 0			
22	SOLENOID VALVE	449 632 050 0			
23	SOLENOID VALVE	449 632 050 0			

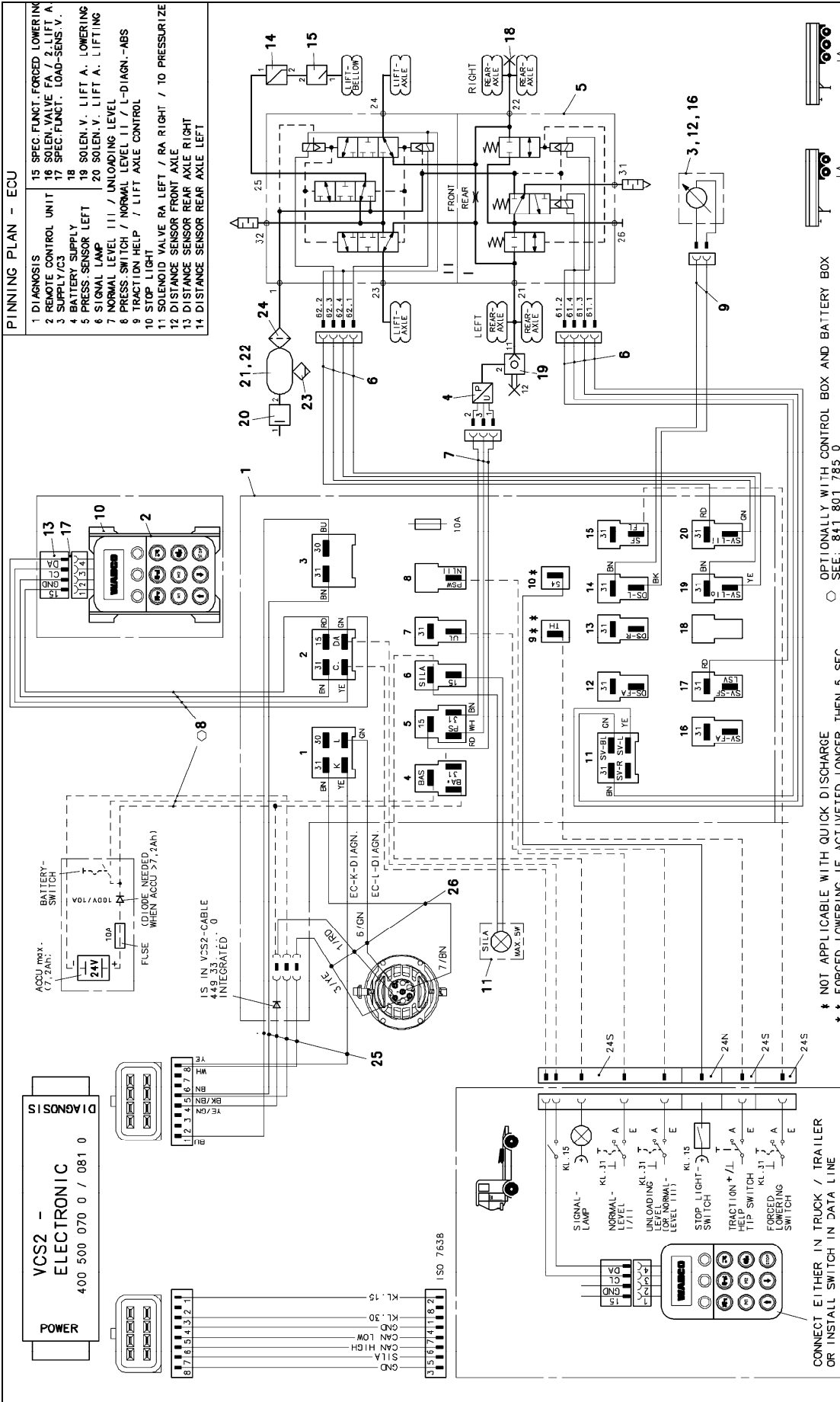

DRAWING INFORMATION		WABCO	
DATE	DESCRIPTION	DATE	DESCRIPTION
08-05-23	AP THY		
08-05-23	STEFMANN		
ECAS-WIRING DIAGRAM			
2-3-AXLES-SEMI TRAILER			
1 DISTANCE SENSOR			
WITH 1 LA. FOR ABS-VCS2			
PRODUCT IDENTIFICATION NO.			
171	841 802 023 0	08E FOR DOCUMENT SHEET	01
SIZE		08E SHEET	
A 2	CODE FOR FUNCTION	0407	REPLACEMENT FOR

5 Device description

The following device descriptions are sorted by product number (first 6 numbers).

5.1 Brake chamber 423 ...

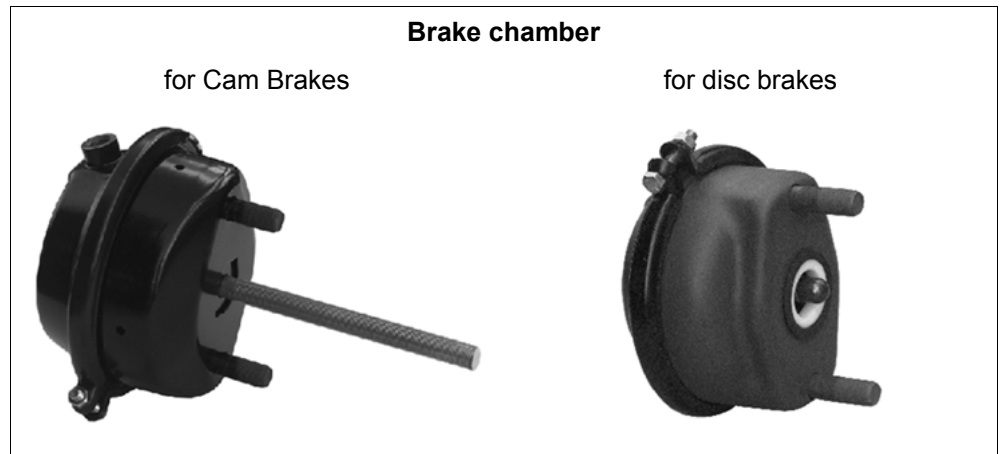

Application

Drawbar trailer and semitrailer with more than one axle.

Brake chambers are used on the axles that do not have to be equipped with Tris-top® cylinders.

Purpose

To generate the brake force for the wheel brakes.

It can also be used to actuate other facilities, e.g. for clamping, raising or gear-shifting.

Maintenance

Special maintenance that extends beyond the legally specified inspections is not required.

Installation recommendation

- Install the diaphragm cylinder at an upward slant to the yoke joints so that any water that is let in can run out again.
- Make sure that the brake line is not lower than the cylinder heads when installing, so that the brake line and the connection points will not be damaged (by ground-contact).
Two couplings on the diaphragm cylinder simplify the line route, which can be used optionally by implementing the screw-plug.
When installing the brake chambers or when adjusting the brake, the push-rod cannot be pulled out.
- Make sure that the cylinder achieves its idle position when the brake is released (the piston does not hang on the brake lever but presses the diaphragm against the rear wall of the housing).
- If the rods of a mechanical park brake assembly also affect the brake lever, then the piston of the cylinder is not to be pulled out past a specified stroke when actuating this assembly. To prevent damages, use a yoke with an oblong slot.

Schematic for installation

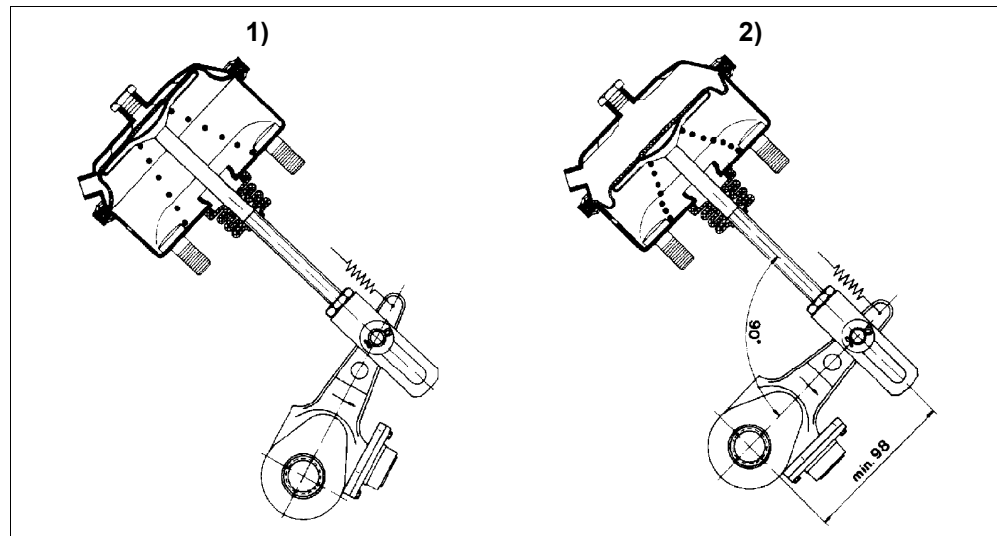
**Key**

- 1) Idle position: No play between piston and diaphragm permitted 2) Operating position: at maximum stroke

! If the diaphragm cylinders have been installed standing up for trailing steering axles (piston rod pointing up), the sealed version is recommended by the axle manufacturers: Order number 24": 423 106 905 0 (with accessories pack)

Installation dimensions – Brake chamber for the cam brake (with bellows)

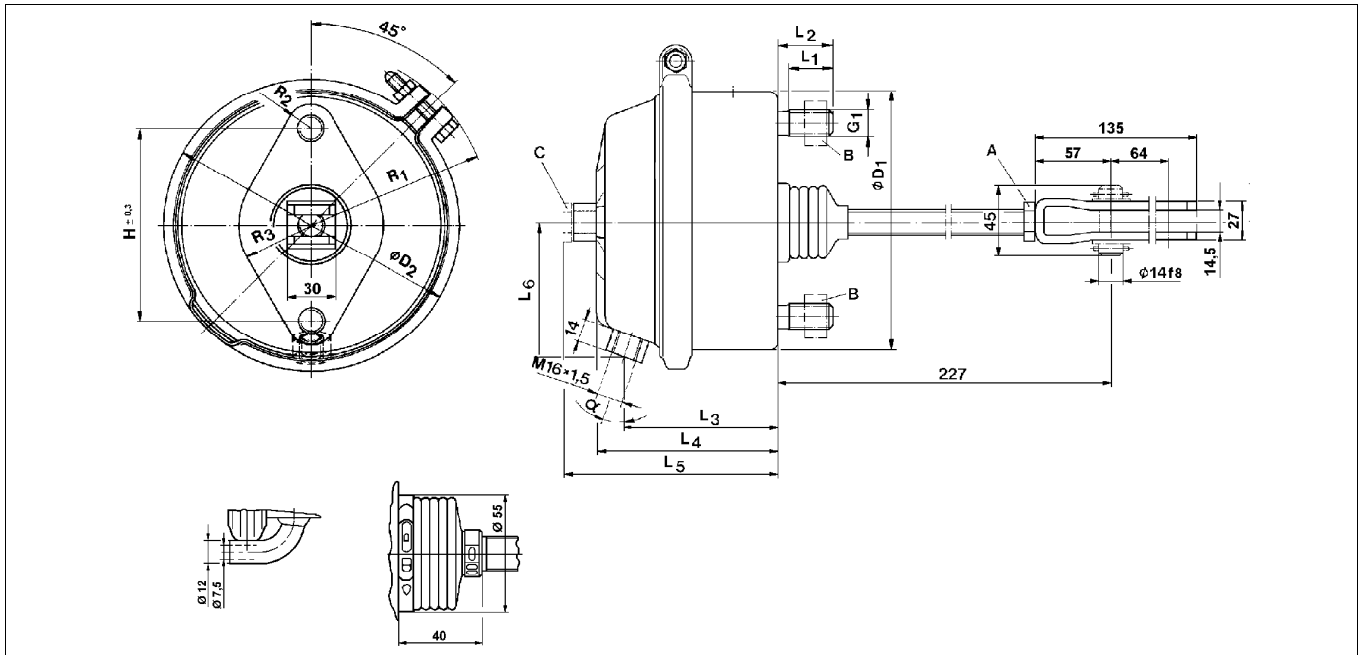

Type	Install dimensions [mm]														
	D ₁	D ₂	G ₁	H	L ₁	L ₂	L ₃	L ₄	L ₅	L ₆	R ₁	R ₂	R ₃	X	α
24	161	185	M 16x1.5	120.7	27	34	96	113	134	85	112	15	45	96	19.5°
36	–	230	M 16x1.5	120.7	27	33	136	152	176	112	133	21.5	55	134	15°

Technical data – Brake chamber for the cam brake (with bellows)

Order number	423 106 905 0* – Type 24	423 008 919 0** – Type 36
Max. stroke	75 mm	76 mm
Volume-stroke at 2/3 stroke	0.93 litre	1.65 litre
Tightening torque A	80 ±10 Nm	
Tightening torque B	180 +30 Nm	
Tightening torque C	45 ±5 Nm	60 ±5 Nm
Accessories pack	423 000 533 2	–
Weight	3.0 kg	4.5 kg
Max. operating pressure	8.5 bar	
Permissible medium	Air	
Operating temperature range	-40 °C to +80 °C	

Key

- * with fording capability: Ventilation with pipe; supplied with accessories pack
- ** The brake chamber type 36 (thread M 22x1.5) is delivered complete, with fastening nuts and screw plug, but with no yoke joint. The yoke joint can be ordered separately, see section "Brake chamber accessories".

Installation dimensions – Brake chamber for the cam brake (with disc seals)

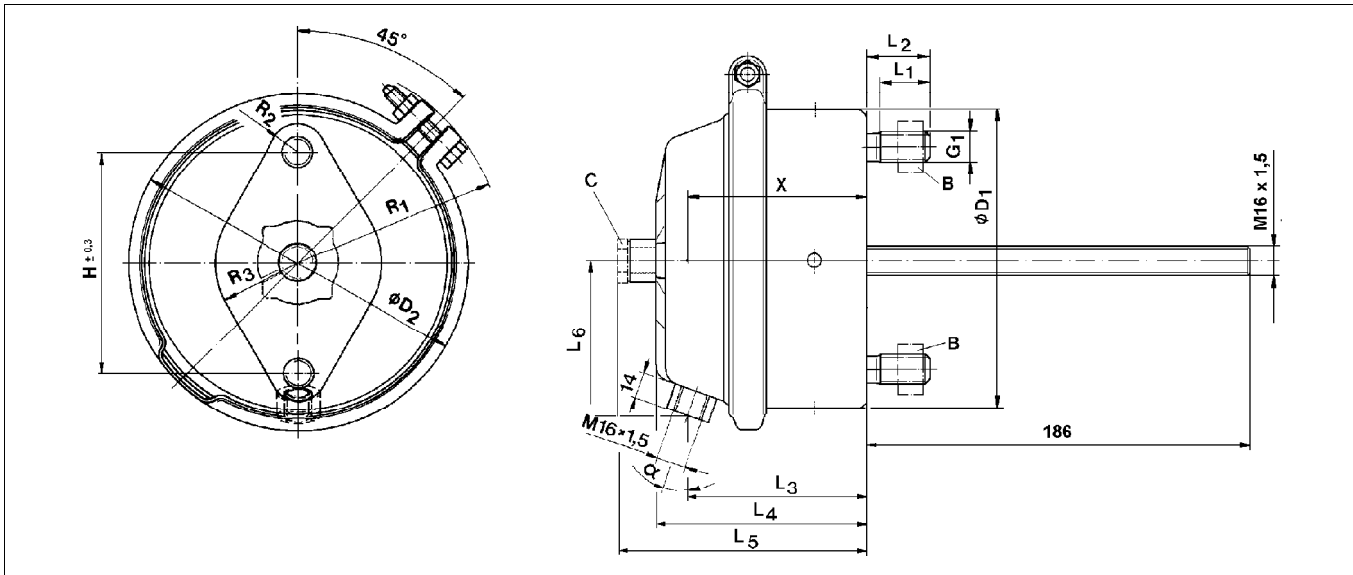

Type	Install dimensions [mm]														
	D ₁	D ₂	G ₁	H	L ₁	L ₂	L ₃	L ₄	L ₅	L ₆	R ₁	R ₂	R ₃	X	α
9	112	135	M 12x1.5	76.2	20	25	97	108	–	63	86	23	32	91	22.5°
12	123	144	M 12x1.5	76.2	20	25.5	103	114	136	66	94	22	34	98	22.5°
16	141	166	M 12x1.5	76.2	20	25.5	96	112	133	75	101	17	35	96	20.5°
20	151	174	M 16x1.5	120.7	27	34	96	112	134	80	105	15	45	96	20.5°
24	161	185	M 16x1.5	120.7	30	34.5	96	113	134	85	111	15	45	103	19.5°
30	162	209	M 16x1.5	120.7	27	34.5	104	113	134	92	123	15	45	102	30°

Technical data – Brake chamber for the cam brake (with disc seals)

Order number	423 102 900 0 Type 9	423 103 900 0 Type 12	423 104 900 0 Type 16	423 105 900 0 Type 20	423 106 900 0 Type 24	423 107 900 0 Type 30
Max. stroke	60 mm			75 mm		
Max. volume-stroke at 2/3 stroke [litres]	0.28	0.40	0.75	0.85	0.93	1.15
Tightening torque A	80 ±10 Nm					
Tightening torque B	70 +16 Nm			180 +30 Nm		
Tightening torque C	–	40 ±5 Nm				
Order number for "Round hole" accessories	423 902 537 2	423 902 533 2		423 000 534 2		
Order number for "Oblong hole" accessories	423 902 536 2	423 902 534 2		423 000 535 2		
Bellows	Yes			No		

Pressure diagrams – Brake chamber for cam brake (with disc seals) Types 9 to 30

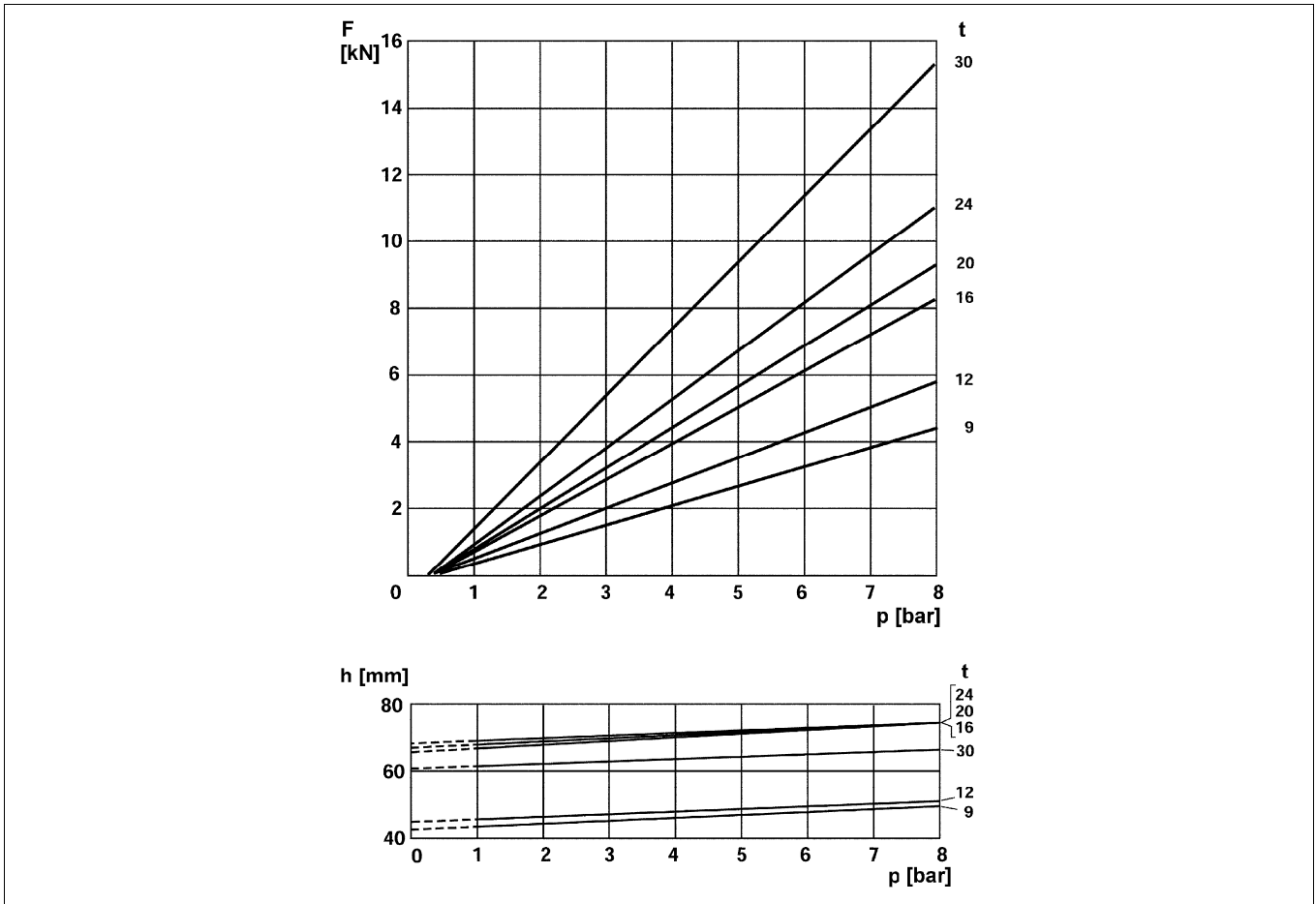

Key

- F** The average piston force is the force determined using an iteration of the values between 1/3 and 2/3 of the overall piston stroke (h_{max}).
- h** The usable piston stroke is the stroke at which the piston force is 90% of the average piston force **F**.
- p** Pressure in brake cylinder
- t** Type

Type	F [N]	h [mm]	h_{max} [mm]
9	$606 \times p - 242$	$0.64 \times p + 44$	60
12	$766 \times p - 230$	$0.57 \times p + 46$	60
16	$1056 \times p - 317$	$0.86 \times p + 68$	75
20	$1218 \times p - 244$	$0.74 \times p + 69$	75
24	$1426 \times p - 285$	$0.56 \times p + 70$	75
30	$1944 \times p - 389$	$0.67 \times p + 62$	75

Installation dimensions – Brake chamber for disc brake

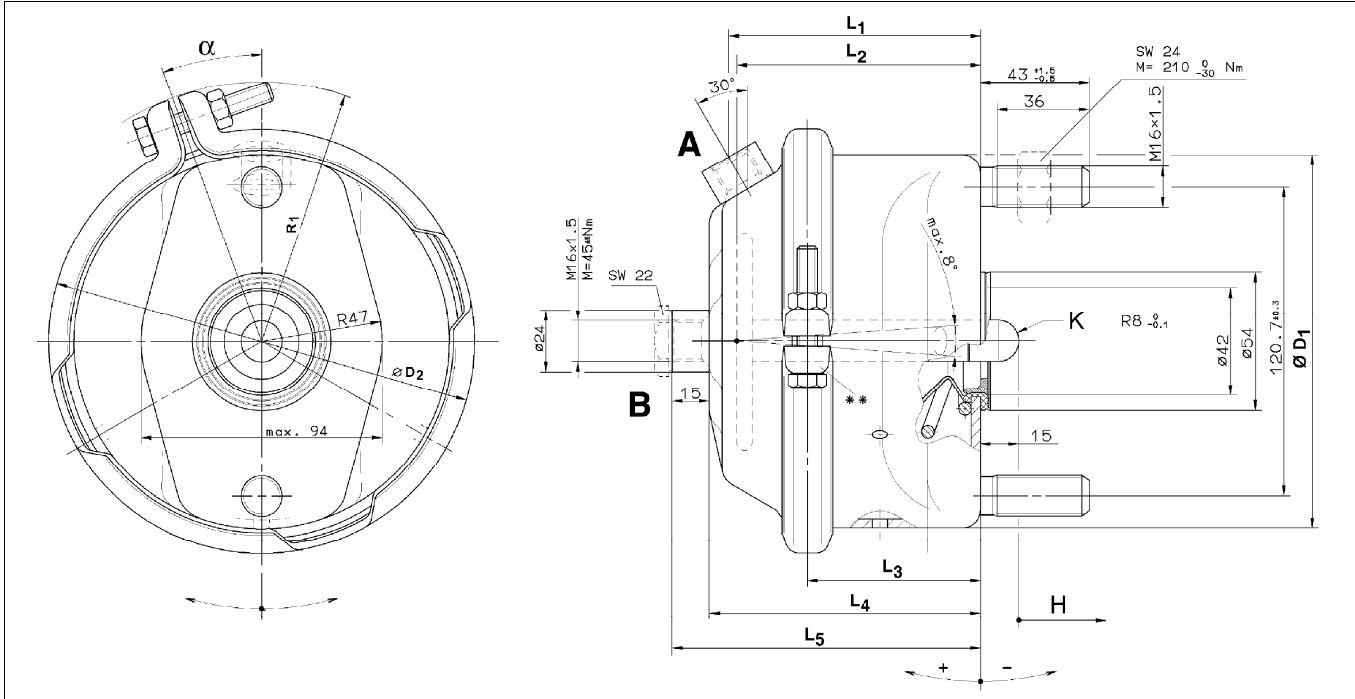

Key	
K	Sphere
H	Stroke

Order number	Type	Install dimensions [mm]									Connection	
		D ₁	D ₂	L ₁	L ₂	L ₃	L ₄	L ₅	R ₁	α	B	B
423 114 710 0	14	146	166	98	95	67	106	121	101	20°	x	1)
423 104 710 0	16	146	166	98	95	67	106	121	101	20°	x	x
423 104 715 0	16	146	166	100	94	66	104	119	103	0°	1)	x
423 104 716 0	16	146	166	100	94	66	104	119	103	90°	1)	x
423 504 003 0	16	146	166	98	92	64	102	117	101	0°	1)	x
423 112 710 0	18	175	175	94	92	65	103	117	106	20°	x	x
423 505 000 0	20	153	175	94	92	65	102	117	106	20°	x	x
423 110 710 0	22	163	185	94	92	65	102	117	111	20°	x	x
423 506 001 0	24	163	185	99	94	65	106	120	112.5	20°	x	x

Key	
1)	with screw plug M 16x1.5

Technical data – Brake chamber for disc brake

Type	14	16	18	20	22	24
Max. deflection of the push rod	8° (with 0 mm stroke)					
Max. stroke	57 mm	62 mm			64 mm	
Volume-stroke at 2/3 stroke [litres]	0.60	0.68	0.71	0.81		
Max. operating pressure	10 bar			10.2 bar		
Thermal range of application	-40 °C to +80 °C					
Weight	3.2 kg	2.8 kg		3.0 kg		

Test results – Brake chamber for disc brakes (types 14 to 24)

F The average piston force is the force determined using an iteration of the values between 1/3 and 2/3 of the overall piston stroke (h_{max}).

h The usable piston stroke is the stroke at which the piston force is 90% of the average piston force **F**.

Type	F [N]	h [mm]	h_{max} [mm]
14	861 x p - 255	1.40 x p + 40	57
16	1062 x p - 308	0.54 x p + 46	57
18	1138 x p - 330	1.19 x p + 47	64
20	1210 x p - 351	1.00 x p + 55	64
22	1332 x p - 373	0.79 x p + 50	64
24	1453 x p - 407	0.57 x p + 48	64

Installation instructions – Brake chamber for disc brake

- Install the brake chamber horizontally so that the opened ventilation hole/drain hole faces downward. Maximum deviation $\pm 30^\circ$
Permissible deviation: 10 with push rod showing upward; 30° showing downwards.
- Be sure to remove the plastic plugs of the lower drain hole.
- Fasten the brake chamber with nuts M 16x1.5 property class 8 (WABCO No. 810 304 031 4)
- Thread on both nuts by hand until the brake chamber makes full contact.
- Then tighten both nuts to approximately 120 Nm and tighten to 210 Nm (Tolerance -30 Nm) with a torque wrench.
If you are using self-locking nuts, the torque must be increased accordingly.

! The piston rod must seat in the slot of the brake lever at / with maximum 10° deflection of the piston rod.
Flange area and sealing surface of brake chamber and disc brake must be clean and undamaged.
The gaiter must have no damages and together with the back-up ring, being properly seated.

Brake chamber accessories

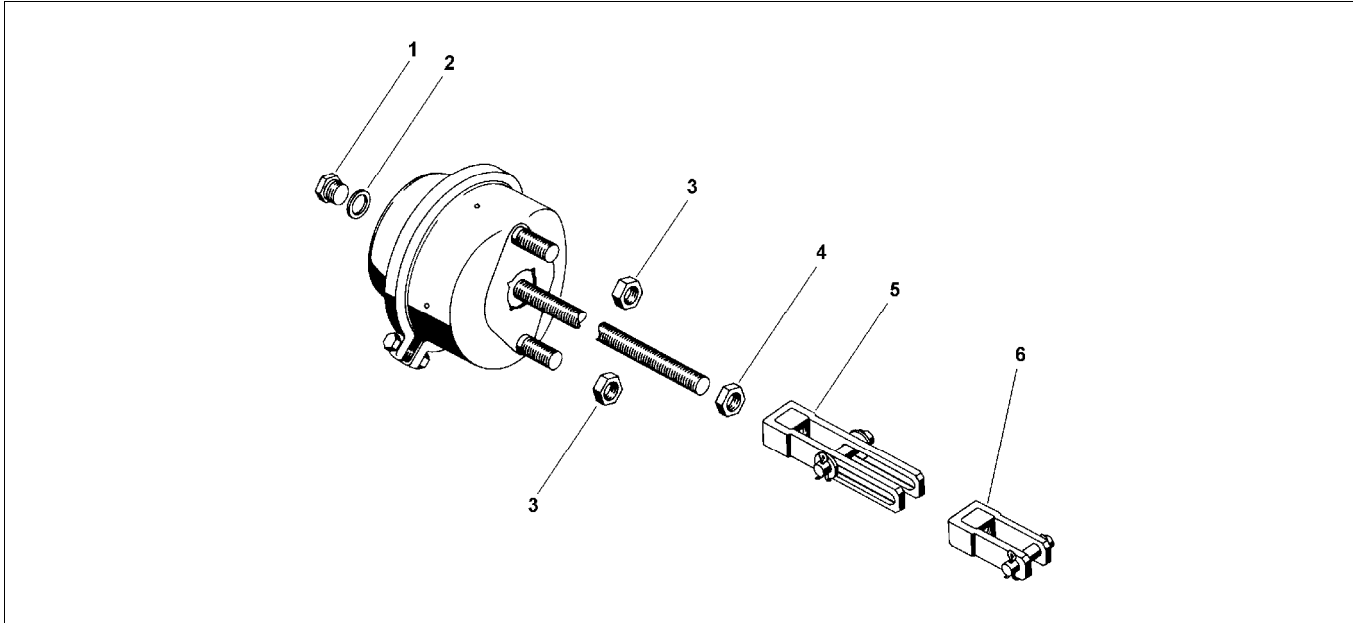

Pos.	Description		Order number	423 000 531 2	423 000 532 2	423 000 533 2	423 000 534 2	423 000 535 2	423 002 530 2	423 103 532 2	423 901 533 2	423 901 538 2	423 902 532 2	423 902 533 2	423 902 534 2	423 902 535 2	423 902 536 2	423 902 537 2	423 903 530 2	
1	Screw plug	M 16x1.5	893 011 710 4	1	1	1	1	1		1			1	1	1					
2	Sealing washer	A 16x20	811 401 057 4	1	1	1	1	1		1			1	1	1					
3	Hexagon nut	M 12	810 304 026 4	2	2				2	2										
		M 12x1.5	810 304 027 4											2	2	2	2	2	2	
		M 16x1.5	810 304 031 4			2	2	2				2								2
4	Hexagon nut	M 14x1.5	810 306 013 4						1	1										1
		M 16x1.5	810 319 029 4	1	1		1	1						1	1			1	1	
5	Yoke joint with bolts Ø 14	M 16x1.5	895 801 310 2		1			1							1		1			
		M 14x1.5	895 801 312 2						1	1										
6	Yoke joint with bolts Ø 14	M 16x1.5	895 801 513 2	1			1							1					1	
		M 14x1.5	895 801 511 2																	1
		M 14x1.5	810 612 020 2																	
-	Pins	14x45x35.6	810 601 100 4			1						1	1							
		14x45x31.2	810 601 097 4								1									
		12x45x34	810 601 084 4													1				
-	Washer	15	810 403 011 4			2					2	2								
-	Split pin	4x22	810 511 034 4			2				2	2	2			2					

5.2 Line filter 432 500



Application

All trailers in the area of the coupling to the truck, for single- and dual-line brakes. As long as there is no filter integrated in the hose couplers already, line filters are inserted into the brake line and the supply line.

Purpose

Protecting the air-brake system from contamination.

Maintenance

- Clean the line filter – depending on operating conditions – every 3 to 4 months. Remove the filter set and blow it out with compressed air.
- Replace the damaged filter inserts.

Installation recommendation

- Install the filter with bulkhead couplings in the pipe system.

! Make sure that there is sufficient space for removing the filter insert (see following figure).

Installation dimensions

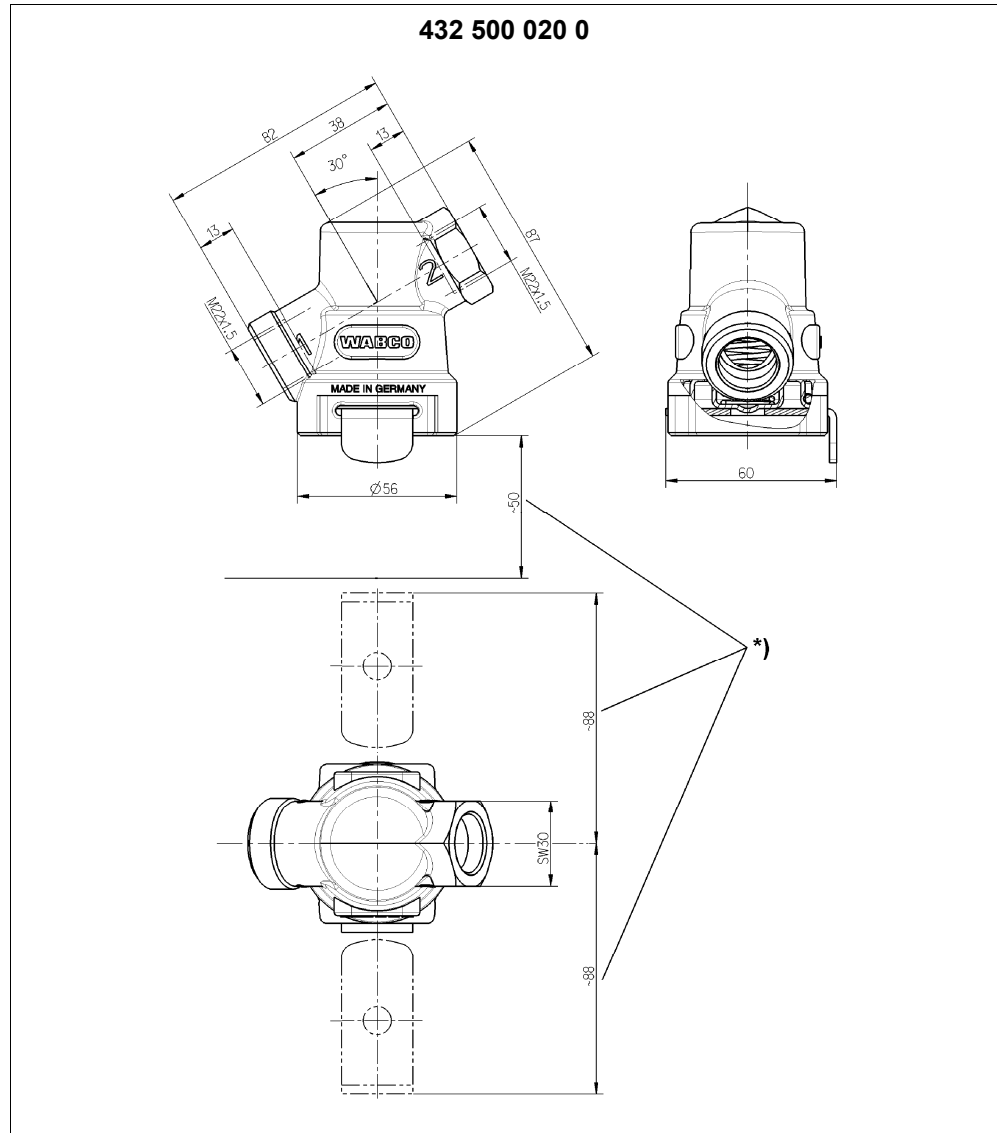

Connections	Key
1 Energy supply 2 Energy delivery	*) Space required for removing filter cartridge

Technical data

Order number	432 500 020 0	432 500 021 0
Max. operating pressure	20 bar	
Free passage	Ø 12 mm = 1.13 cm ²	
Port threads	M 22x1.5	M 16x1.5
Pore size of filter	80 to 140 µm	
Permissible medium	Air	
Thermal range of application	-40 °C to +80 °C	
Weight	0.29 kg	
Remark	-	

5.3 Exhaust filter 432 70.

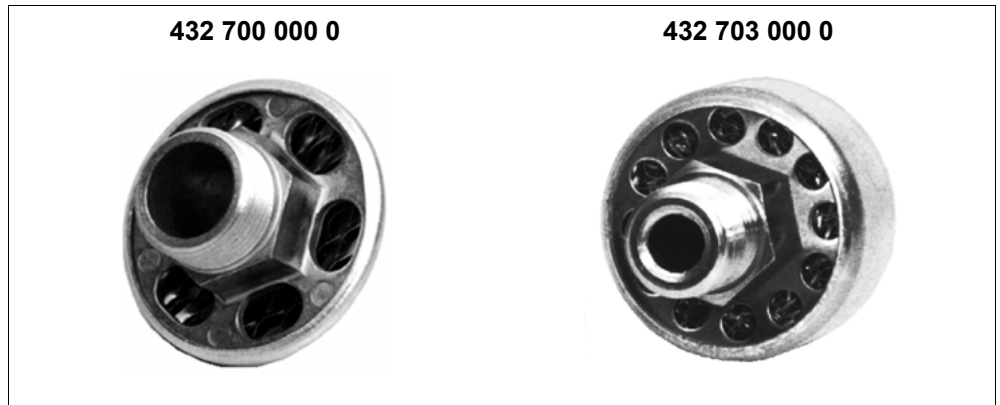

Application

Installation in the exhaust opening of compressed air actuated brake and control devices.

Purpose

Damping exhaust noise.

Maintenance

Special maintenance that extends beyond the legally specified inspections is not required.

Installation recommendation

- Install the exhaust filter in an optional location.
Sufficient space for mounting/dismounting on the compressed air device.

Installation dimensions

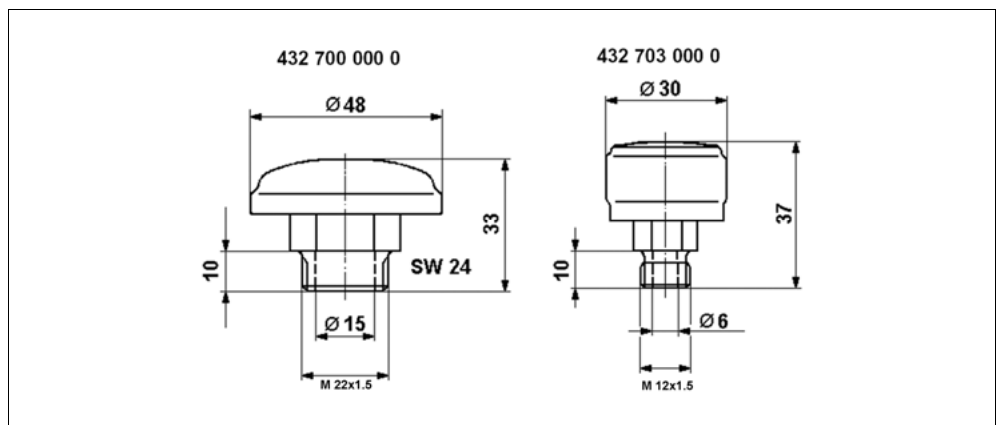

Technical data

Order number	432 700 000 0	432 703 000 0
Port threads	M 22x1.5	M 12x1.5
Permissible medium	Air	
Thermal range of application	-40 °C to +125 °C	-40 °C to +120 °C
Weight	0.03 kg	0.02 kg

5.4 Knuckle joint 433 306

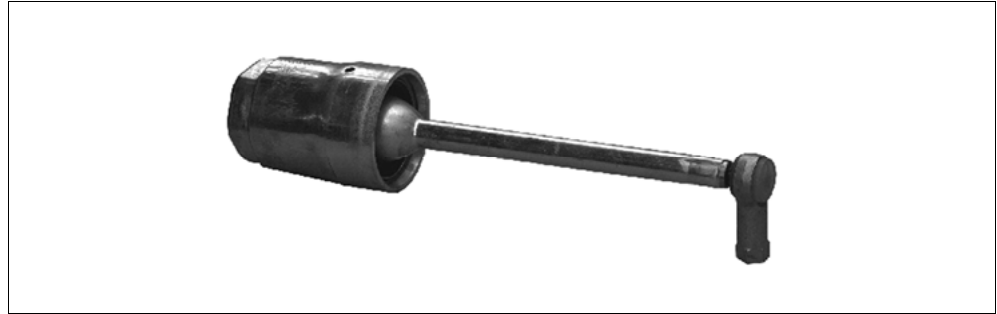

Application

Vehicles with leaf-springs.

Knuckle joints are used in combination with mechanical LSV controllers.

Purpose

Prevents damages to load-dependent control valves or automatic brake force controllers, if the axle suspension is compressed or extended past the normal distance.

Maintenance

Special maintenance that extends beyond the legally specified inspections is not required.

Installation regulations

- Choose the knuckle joint that guarantees that the path exceeding the adjustment range of the controller is not greater than the possible displacement h .
- For trailers – single and dual-axle – take the dimension for the displacement h from the following diagram:

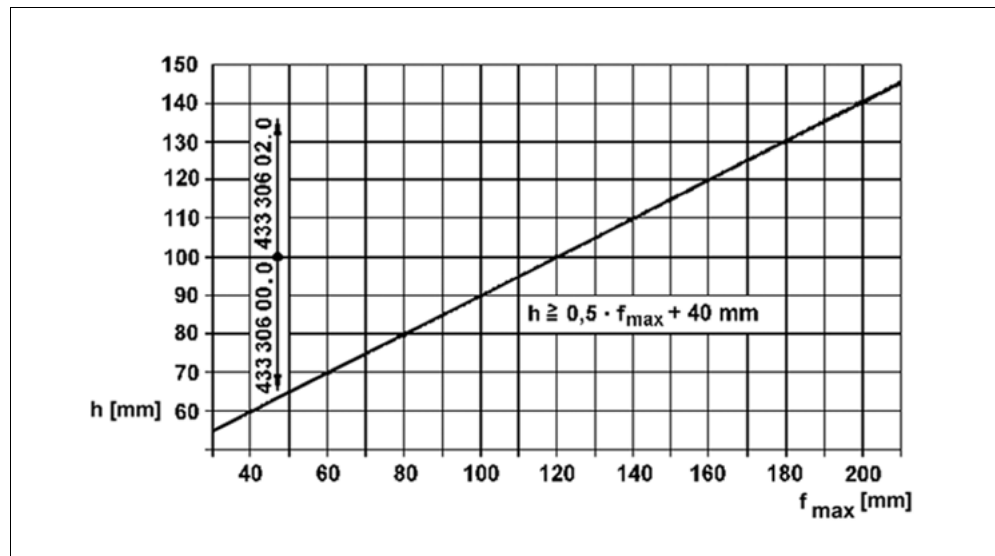

Key

h Displacement f_{\max} Max. spring deflection according to the specifications of the axle manufacturer

- Fasten the knuckle joint to the single axle or between the two axles of the dual-axle assembly based on the respective instructions of the axle manufacturer.

- Arrange the knuckle joint so that its ball joint is seated in the neutral point of the axle or axles.

The "neutral point" is the point that is free of outside influence:

Twisting movement of the axle during braking procedure

Wandering in curves with steering axles

One-sided load on the axle with uneven streets

! Only the static and dynamic axle changes are permitted to be the initiation for adjusting the automatic brake force controller.

- Connect the knuckle joint through a round rod with an M8 thread and hexagon nut M8 DIN 934 (not included in delivery) with the adjustment lever of the automatic brake force controller.
The length of this connection rod depends on the mounting of the devices on the vehicle.
- Depending on the existing fastening capabilities for the connecting rod of the brake force controller to be used, either leave the connecting rod smooth or apply an M8 thread of approx. 25 mm in length.
- Thread an M8 DIN 934 hexagon nut onto the thread.
- Screw the other end of the connecting rod into the ball joint and secure it with the hexagon nut.
- Carefully trim the smooth ends to prevent any damage to the rubber thrust members.

Installation dimensions

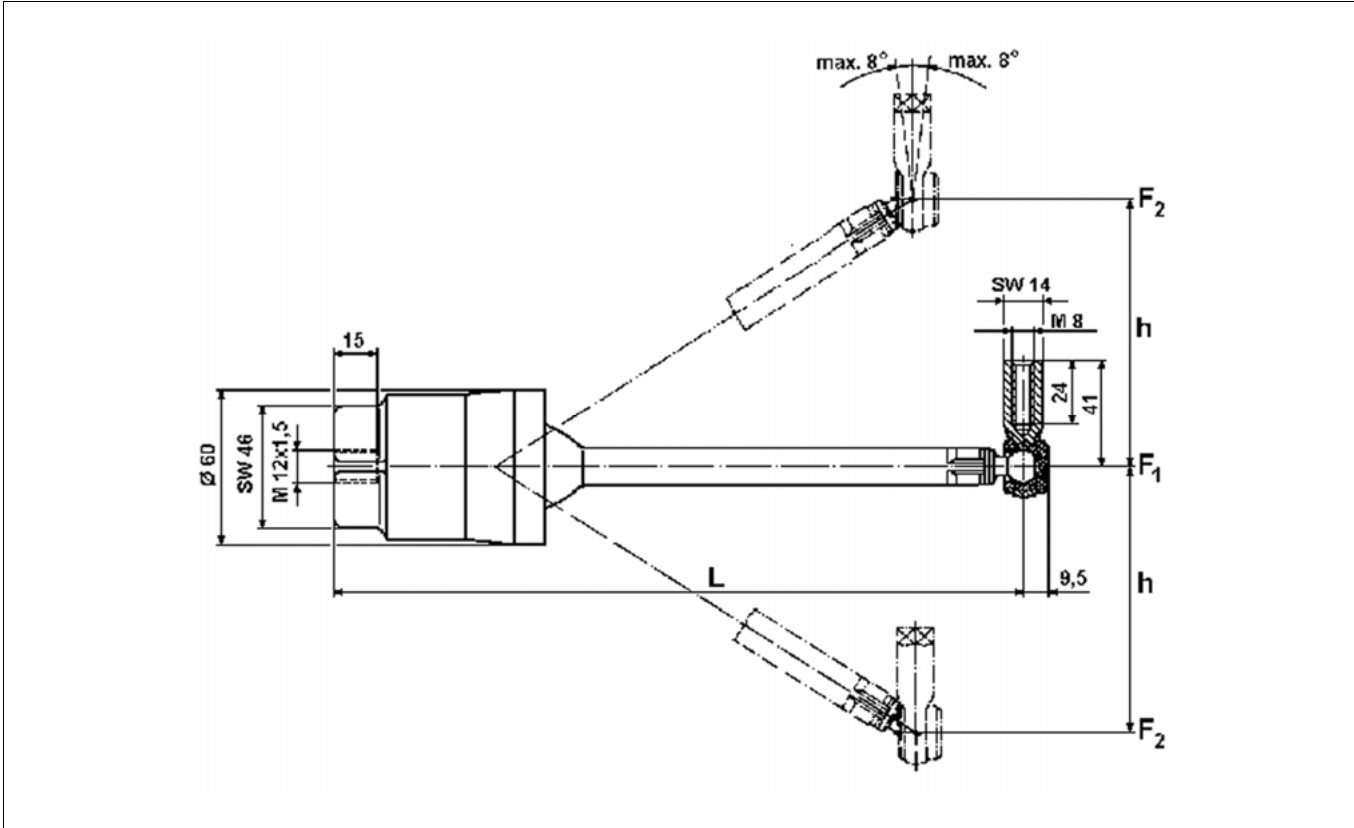

Technical data

Order number	Length L [mm]	Displacement h [mm]	Displacement [N]	
			F ₁	F ₂
433 306 002 0	260	100	90	190

5.5 Linkage 433 401



Application

If threaded onto the axle.

Purpose

A flexible rubber connection for the guiding the air suspension valve 464 006 ... or an ECAS distance sensor.

Installation recommendation

- Use a flat iron to fasten the linkage on the vehicle axle.
The $\varnothing 6$ pipe for the connection between the two rubber sleeves (adjustment lever of the air suspension valve and the linkage) does not belong in the scope of delivery.

Installation dimensions

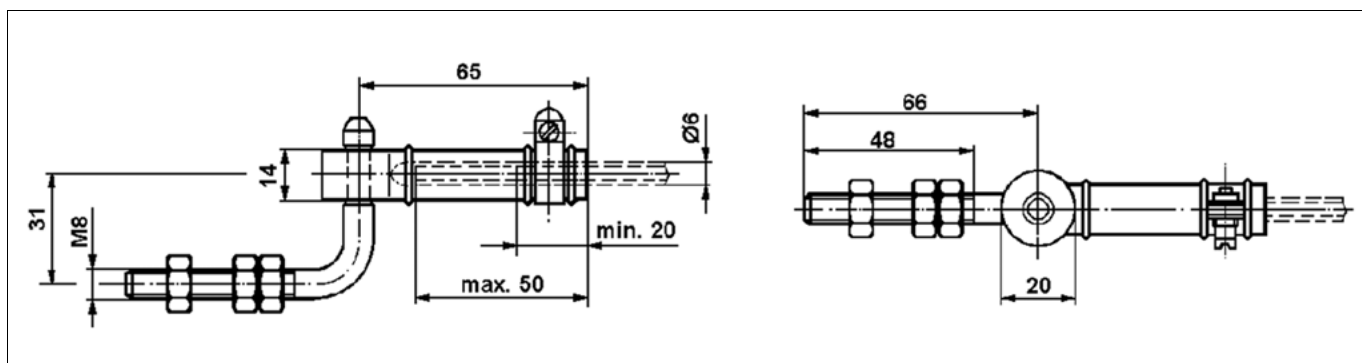

5.6 Check valve 434 014

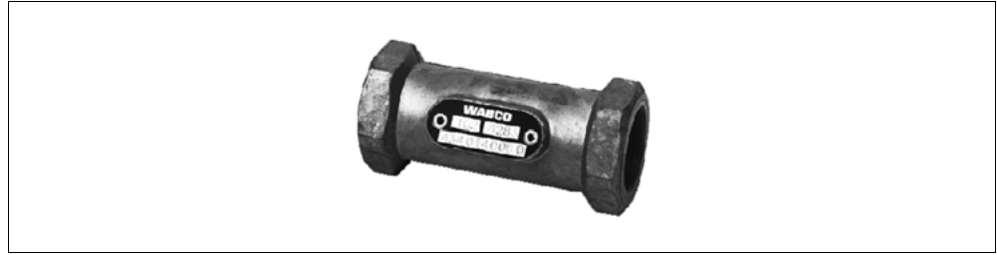
**Application**

For multiple applications in compressed air systems.

Purpose

To protect the pressurized lines against unintentional venting.

Maintenance

Special maintenance that extends beyond the legally specified inspections is not required.

Installation recommendation

- Install the charging valve in any position in the pipe lines.

! Pay attention to the arrow on the housing that shows the direction of flow during the installation.

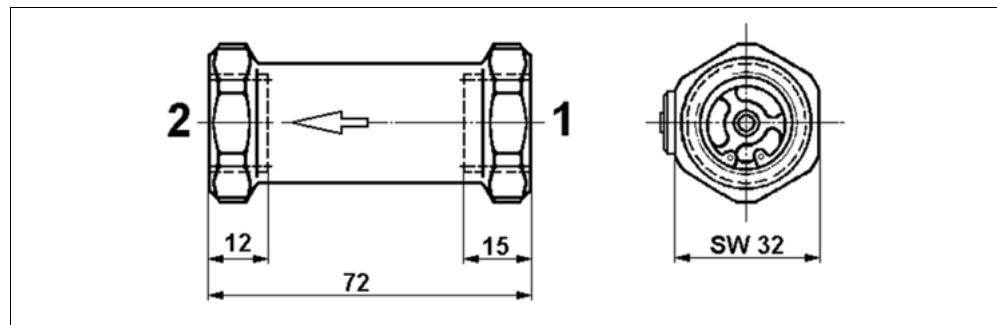
Installation dimensions**Technical data**

Order numbers	434 014 000 0	434 014 001 0
Max. operating pressure	20 bar	
Nominal diameter	Ø 8 mm	
Port threads	M 22x1.5	
Permissible medium	Air	
Thermal range of application	-40 °C to +80 °C	
Weight	0.17 kg	
Comment	–	Constant throttling Ø 1 mm

5.7 Charging valve 434 100



Application

Multiple applications in compressed air systems.

Purpose

Charging Valve with Return Flow

The passing of compressed air to second air brake reservoir only when the rated pressure for the system in the first reservoir has been reached.

If the pressure in the first reservoir falls below that of the second reservoir there is a feedback supply of air from the second reservoir.

Charging valve without return flow

Residual pressure maintenance in lifting bellows of a lift axle to prevent the bellows from wrinkling when the lift axle is lowered. The passing of compressed air to auxiliary equipment (e. g. door actuation, auxiliary and parking braking systems, servo clutch, etc.) only when the rated pressure for the braking system has been reached.

Charging valve with limited return flow

The passing of compressed air to other consumers (e. g. auxiliary and parking braking systems) only when the rated pressure for the braking system has been reached.

Also the protection of pressure for the motor vehicle in the event of the trailer's supply line failing.

If the pressure in the air reservoirs of the service braking system drops, part of the compressed air will return until the closing pressure (which is dependent on the opening pressure) is reached.

Maintenance

Special maintenance that extends beyond the legally specified inspections is not required.

Installation recommendation

- Install the charging valve anywhere within the flow of the pipe lines..

! Pay attention to the arrow on the housing that shows the direction of charge flow during the installation.

Installation dimensions

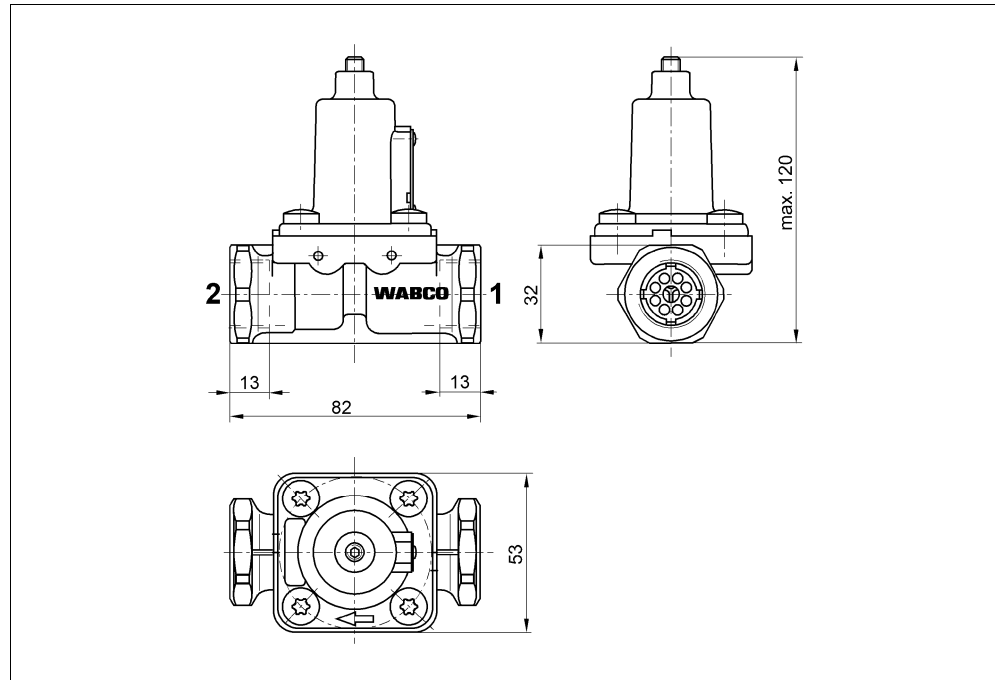

Connections

1 Energy supply

2 Energy delivery

Technical data

Order numbers	434 100 ... 0
Max. operating pressure	13 bar
Nominal diameter	Ø 8 mm
Port threads	M 22x1.5
Permissible medium	Air
Thermal range of application	-40 °C to +80 °C
Weight	0.45 kg

Order number	Valve type	Charging pressure (Tolerance -0.3 bar)
434 100 024 0	with back-flow	6.0 bar
434 100 027 0	with back-flow	0.5 bar
434 100 122 0	without backflow	4.5 bar
434 100 124 0	without backflow	5.5 bar
434 100 125 0	without backflow	6.0 bar
434 100 126 0	without backflow	6.5 bar
434 100 222 0	with limited back-flow	6.2 bar (Closing pressure = Charging pressure -15 %)

5.8 Two-way valve 434 208



Application

Multiple applications in compressed air systems.

Truck example: Actuation of brake cylinder with brake system or ASR system.

Trailer example: Control of another axle with higher brake pressure of Trailer EBS.

Purpose

The output pressure increase controlled from two separate inputs.

Maintenance

Special maintenance that extends beyond the legally specified inspections is not required.

Installation recommendation

- Install the two-way valve with connections 11 and 12 horizontally (see DIN 74 341) loosely in the pipe line.

Installation dimensions

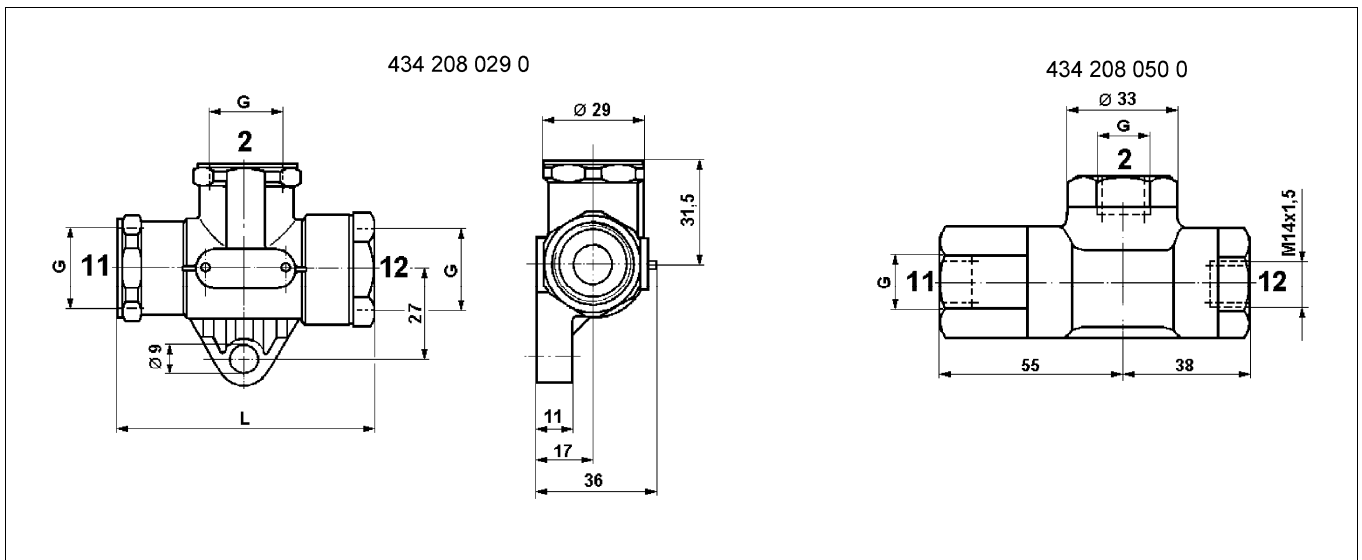

Connections				Key	
2	Energy delivery	11	Energy supply	12	Energy supply
				G	Thread

Technical data

Order number	434 208 029 0	434 208 028 0	434 208 050 0
Max. operating pressure	10 bar		
Install dimension L	76 mm	93 mm	
Nominal diameter	Ø 12 mm		Ø 10.5 mm
Port threads	M 22x1.5 - 12 deep	M 16x1.5 - 12 deep	
Permissible medium	Air		
Thermal range of application	-40 °C to +80 °C		
Max. tightening torque	53 Nm		
Weight	0.15 kg	0.39 kg	

5.9 Pressure switch 441 009 / 441 014

Pressure switch 441 009



Application

Multiple applications in compressed air systems. Separate housing, switches exclusively to ground.

Purpose

The pressure switch is used for switching electrical devices or indicator lights on or off.

Maintenance

Special maintenance that extends beyond the legally specified inspections is not required.

Installation recommendation

- Install the 1-pole pressure switch in any location in the pressure line.
- Fasten the pressure switch with one M8 bolt.

! Make sure that fastening is made to a proper ground contact (do not fasten to plastic parts).

- Put a cable eyelet on the cable to be connected.

Installation dimensions

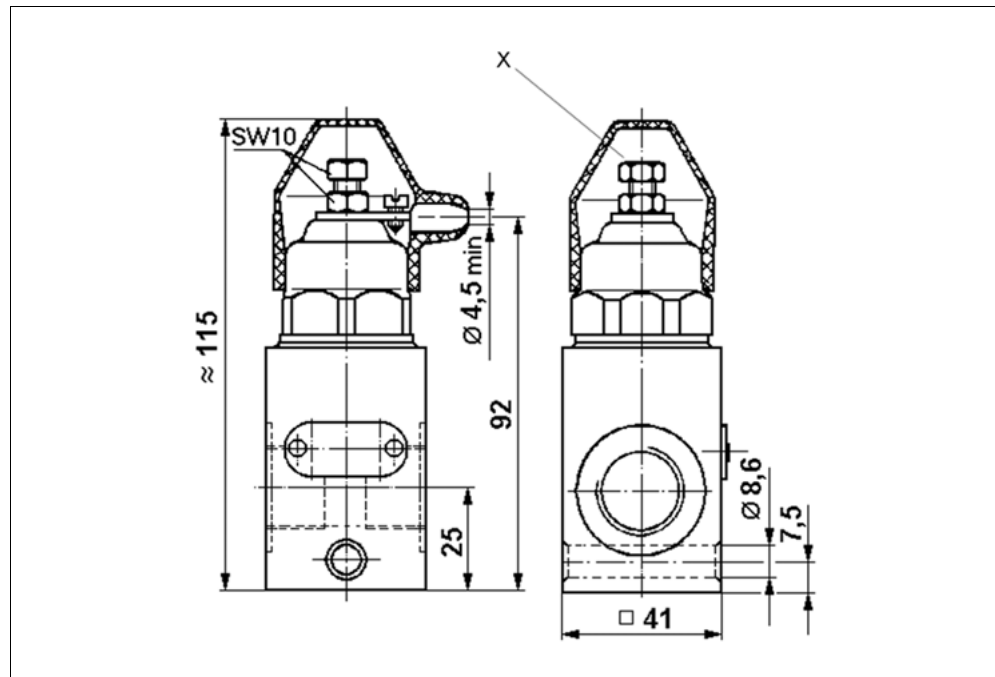

Key

X Adjusting screw

Technical data

Order number	441 009 001 0 On switch	441 009 101 0 Off switch
Max. operating pressure	10 bar	
Actuating pressure	Set to 5.0 ±0.2 bar	
	can be adjusted from 1.0 to 5.0 bar	
Port threads	M 22x1.5	
Max. operating voltage (DC voltage)	30 V	
Max. electrical breaking capacity with inductive load and direct current	2 A	
Permissible medium	Air	
Thermal range of application	-40 °C to +80 °C	
Weight	0.22 kg	

Pressure switch 441 014



Application

Multiple applications in compressed air systems.

Purpose

The pressure switch is used, depending on the version, for switching electrical devices or indicator lights on or off.

Installation dimensions

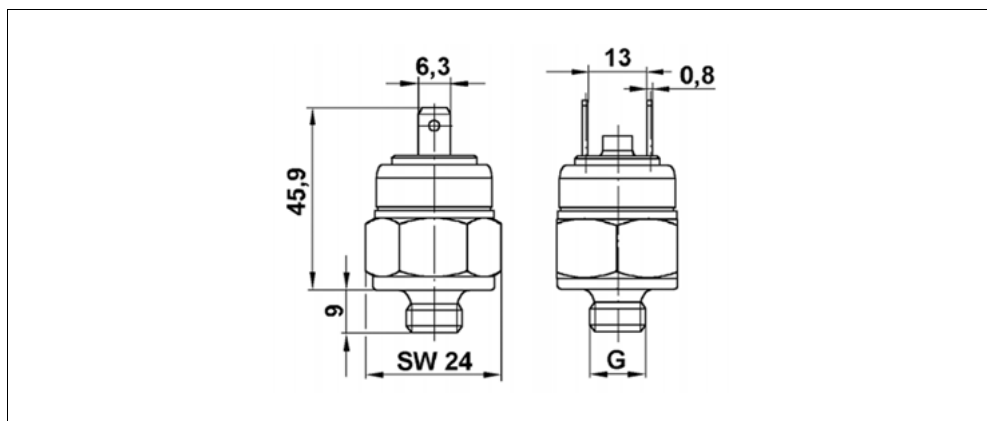

Technical data

Order number	441 014 021 0 On switch	441 014 023 0 On switch
Max. operating pressure	10 bar	
Actuating pressure	0.5 ±0.15 bar	2.5 ±0.3 bar
Port threads	M 12x1.5	
Voltage (direct current)	24 V	
Operating temperature range	-40 °C to +80 °C	
Weight	0.06 kg	

5.10 Pressure sensor 441 044

**Application**

Multiple applications in compressed air systems for monitoring pressure.

Purpose

Conversion of a pneumatic pressure valve into an analogue electrical signal that can be evaluated by controller electronics.

Technical data

Order number	441 044 102 0
Max. operating pressure	10 bar
Electrical connection	Bayonet (DIN), DIN 72585-A1-3.1-Sn/K2
Port threads	M 16x1.5
Thermal range of application	-40 °C to +80 °C
Permissible medium	Air
Voltage	8 - 32 V DC
Sensitivity	400 mV/bar
Sealing washer	897 770 250 4
Weight	0.03 kg

5.11 Shut-off cock with venting 452 002 / 952 002

**Application**

Multiple applications in compressed air systems.

Purpose

Shutting off compressed air lines.

Maintenance

Special maintenance that extends beyond the legally specified inspections is not required.

Installation recommendation

- Fasten the shut-off cock with two M8 bolts.

! Make sure of the flow direction (arrow direction) when installing and that there is sufficient room for actuating the lever.

Installation dimensions

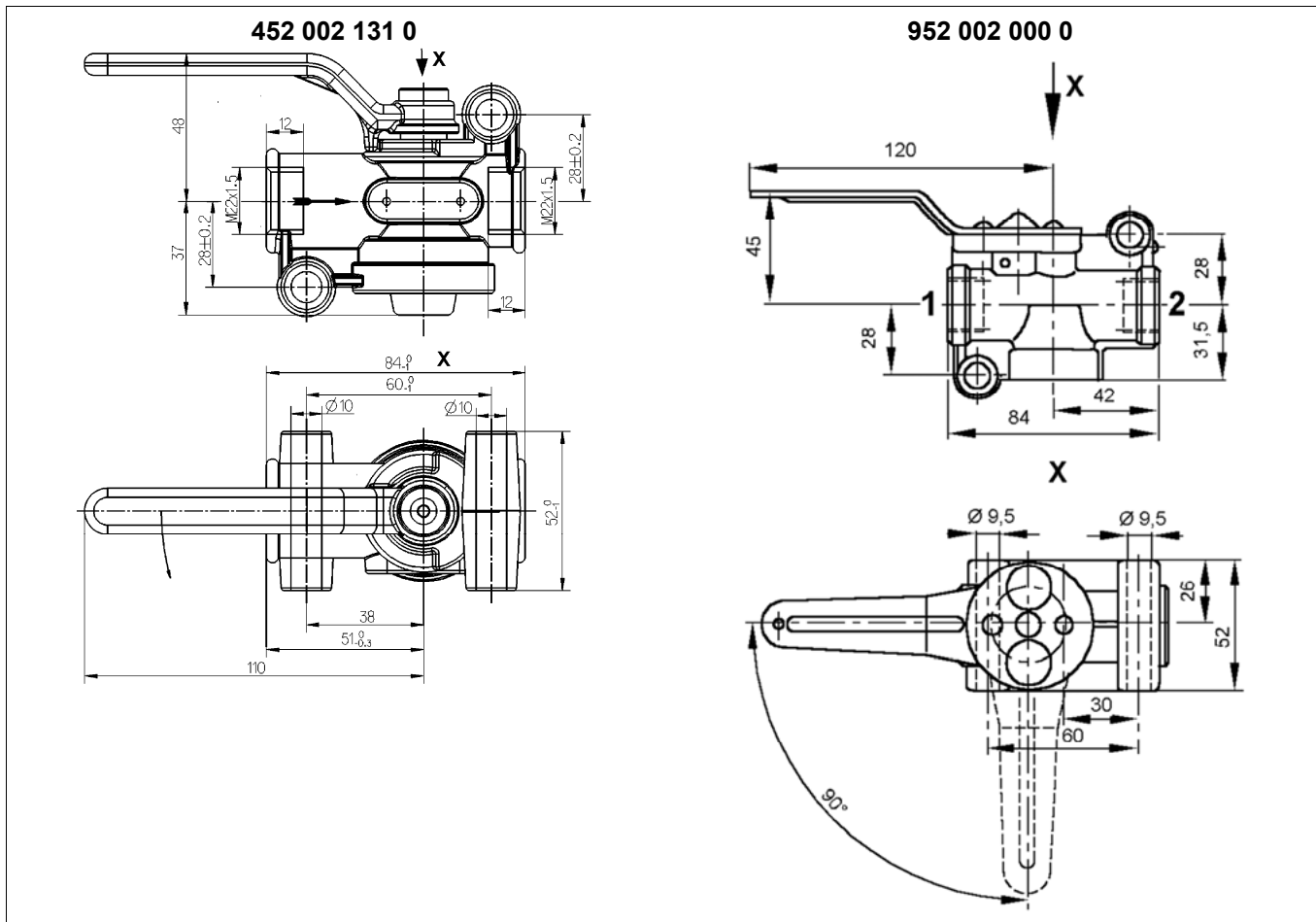

Key

View X

Technical data

Order number	452 002 131 0	452 002 132 0	452 002 133 0	952 002 000 0
Max. operating pressure	10 bar			
Port threads	M 22x1.5 - 12 deep			
Lever actuation a/b	90°			
Permissible medium	Air			
Thermal range of application	-40 °C to +80 °C			
Weight	0.26 kg	0.26 kg	0.26 kg	0.58 kg

Shut-off Cock	90° left	0°	90° right
452 002 131 0	Closed	open	Closed
452 002 132 0	Vented	Pressurized	Vented
452 002 133 0	Closed	Pressurized	Vented
952 002 000 0	Closed	open	Closed

5.12 Dummy coupling with fastening 452 402



Application

Semitrailer tractors and drawbar trailers.

Purpose

Holder for disconnected brake lines with hose coupler.

Technical data

Order number	452 402 000 0	452 402 002 0
For hose couplings	452 200 / 952 200	452 201
Weight	0.3 kg	

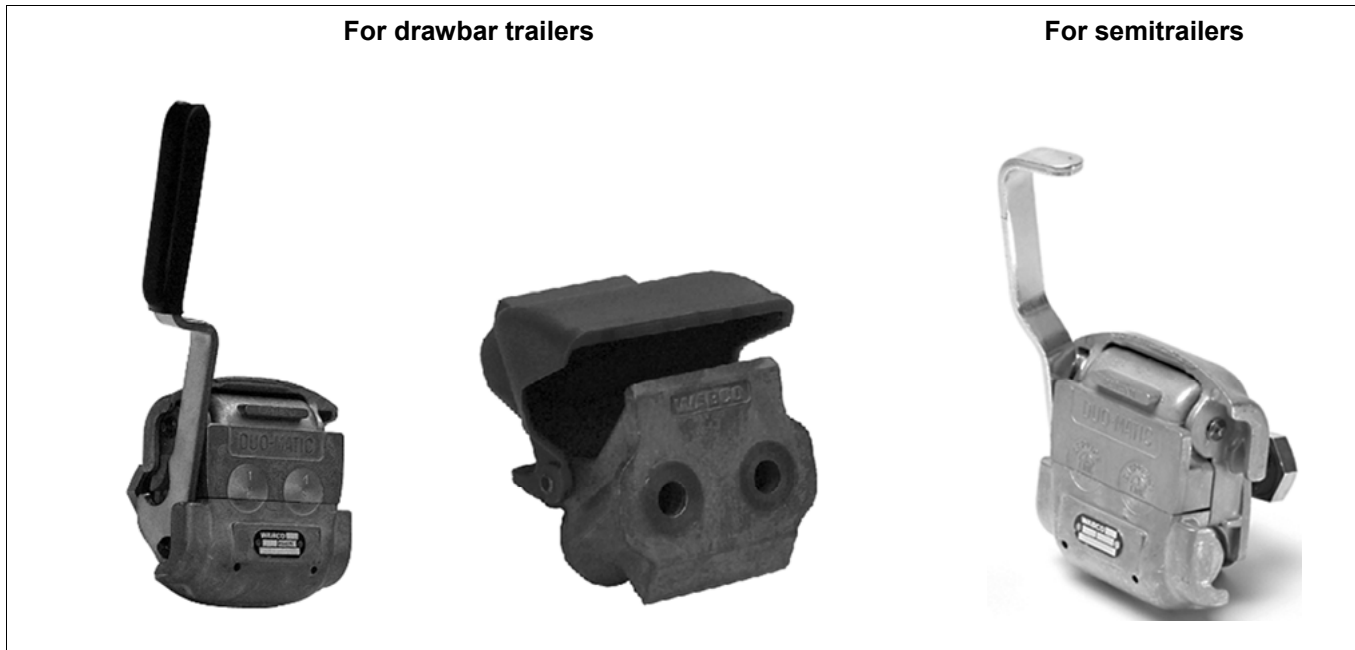
5.13 Duo-Matic quick-coupling 452 80.**Application**

Connection of truck and trailer instead of using hose couplers

Purpose

Connect the air braking system of the motor vehicle with the brake system of the trailer.

With Duo-Matic quick couplings, the trailer vehicles can be coupled quicker and more securely than with standard hose couplers.

Maintenance

Special maintenance that extends beyond the legally specified inspections is not required.

Installation recommendation

- Install the Duo-Matic quick-coupling according to ISO 1728 (see following installation diagram).

Installation diagram

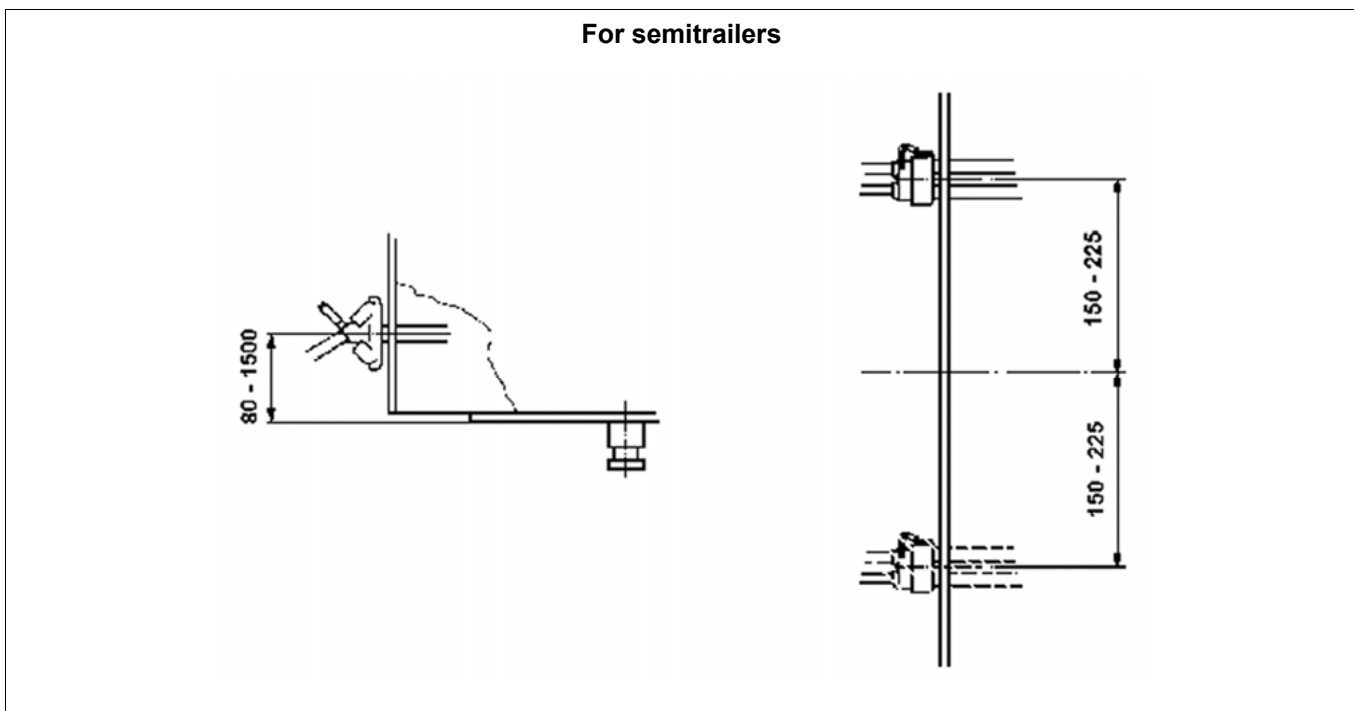
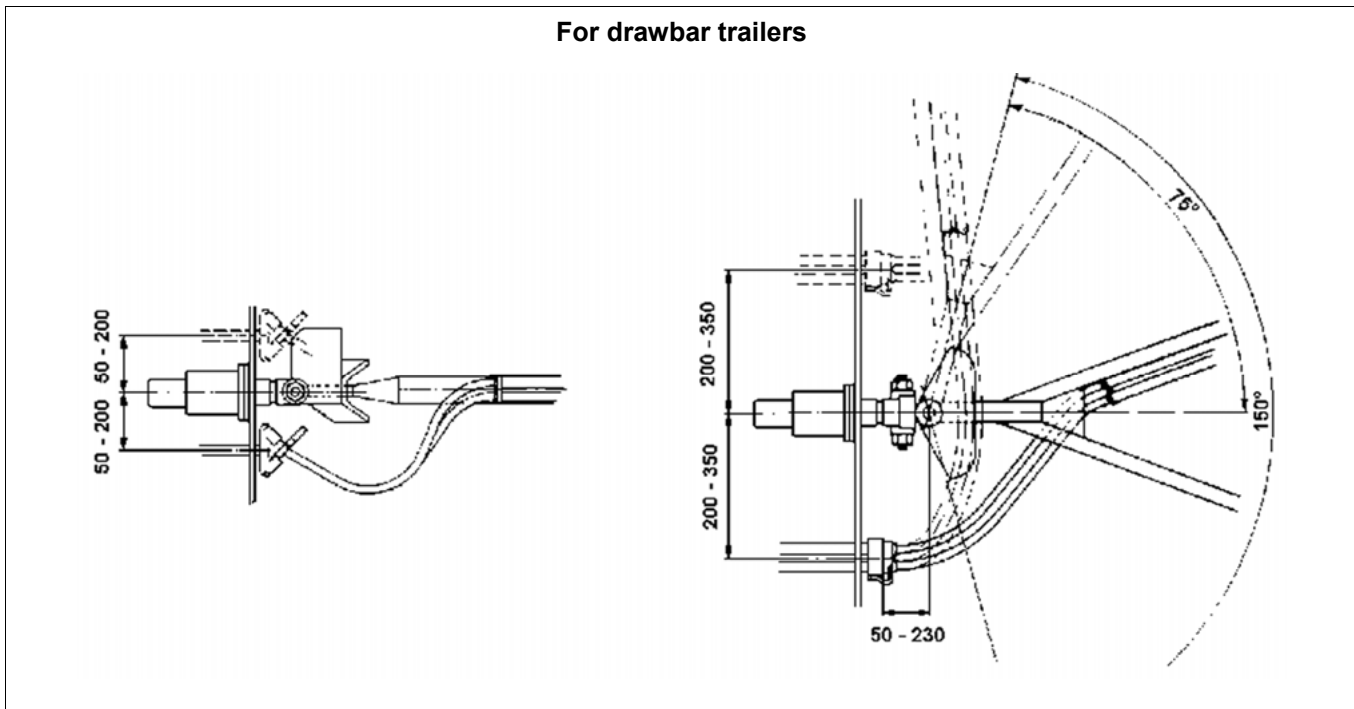

Installation dimensions

For drawbar trailers

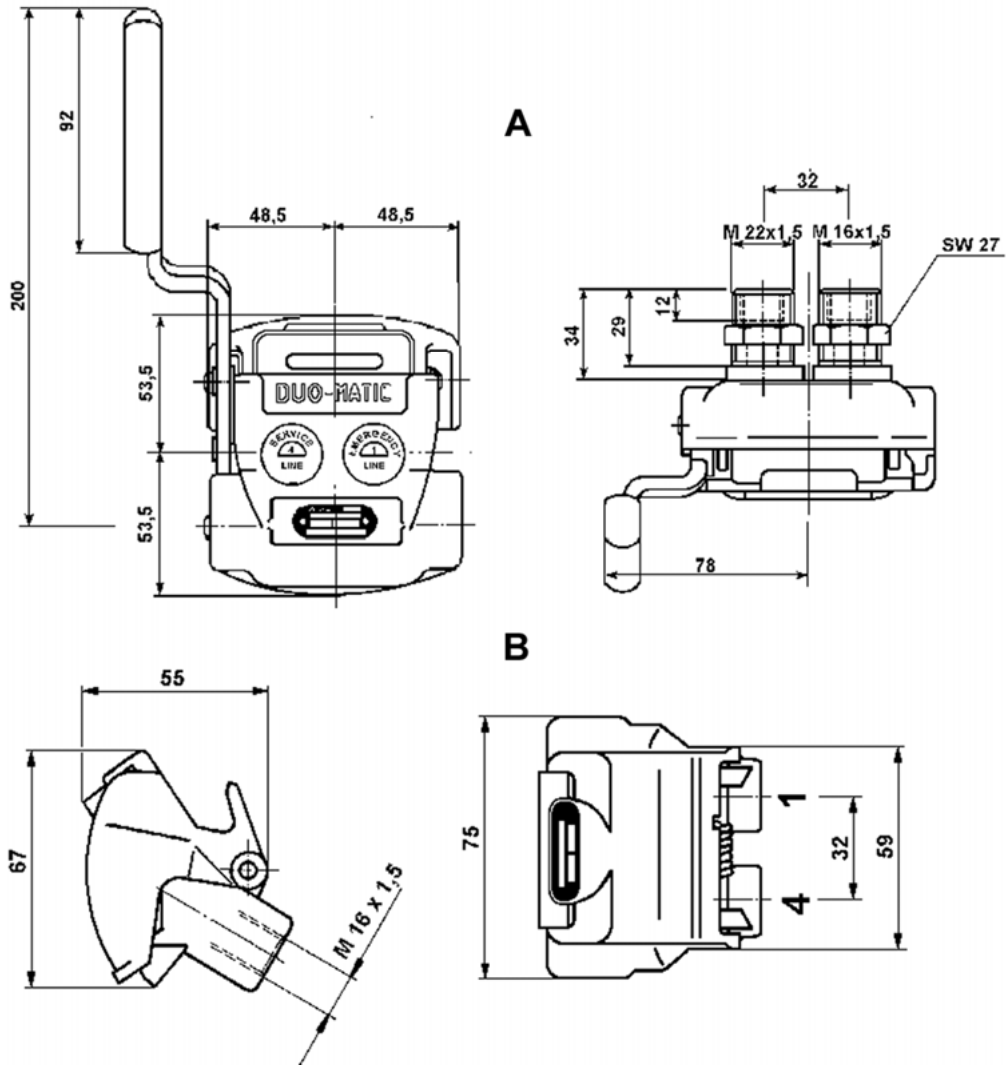

Connections

Key

1	Energy supply	4	Control port	A	Vehicle part	B	Drawbar trailer part
---	---------------	---	--------------	---	--------------	---	----------------------

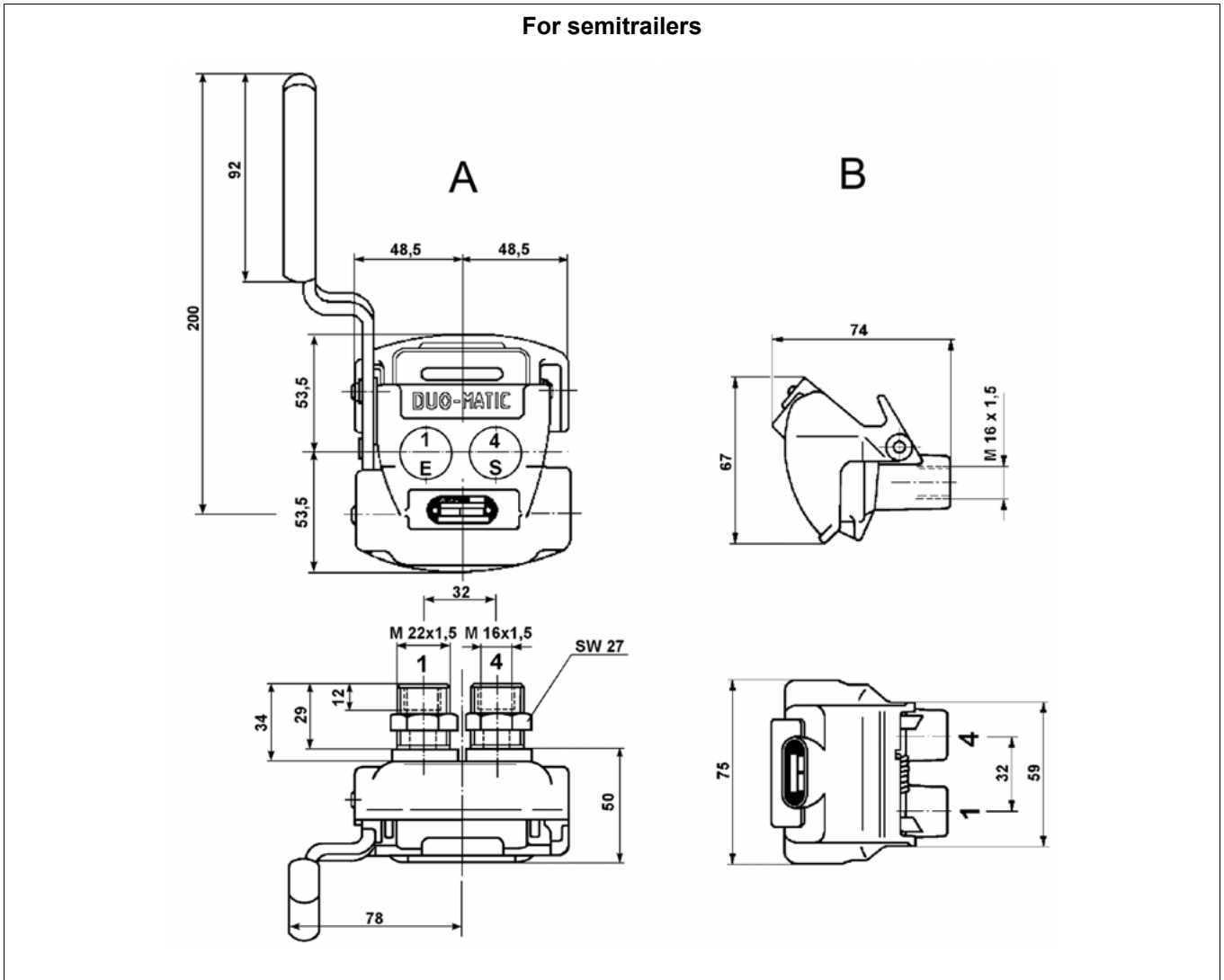

Connections		Key	
1	Energy supply	4	Control port
A	Vehicle part	B	Semitrailer part

Technical data

Order number	For drawbar trailers		For semitrailers			
	452 802 009 0 Vehicle part	452 804 012 0 Drawbar trailer part	452 803 0050 Semitrailer part	452 805 004 0 Vehicle part	452 802 007 0 Semitrailer part	452 803 004 0 Vehicle part
Quick connector	No		No		Yes	
Max. operating pressure	10 bar		10 bar			
Nominal diameter	9 mm		9 mm			
Permissible medium	Air		Air			
Thermal range of application	-40 °C to +80 °C		-40 °C to +80 °C			
Weight	1.0 kg	0.2 kg	1.0 kg	0.3 kg	1.08 kg	1.17 kg

5.14 Rotary slide valve 463 032



Application

Air-suspension vehicles with conventional control.

With air-suspension with spring-distances of > 300 mm, a version of deadman switch is required (variants 463 032 1.. 0).

Purpose

Control of raising and lowering air-suspension vehicles with a hand lever.

On variants with deadman switch, the hand lever is automatically moved back into idle position when it is released to prevent accidents.

Maintenance

Special maintenance that extends beyond the legally specified inspections is not required.

Installation recommendation

- Install the rotary slide valve vertically so that the vent 3 points downward.
- Fasten the rotary slide valve with two M8 bolts.
- Attach the provided sign displaying the lever settings under the lever (see following installation dimensions as well).

Installation dimensions

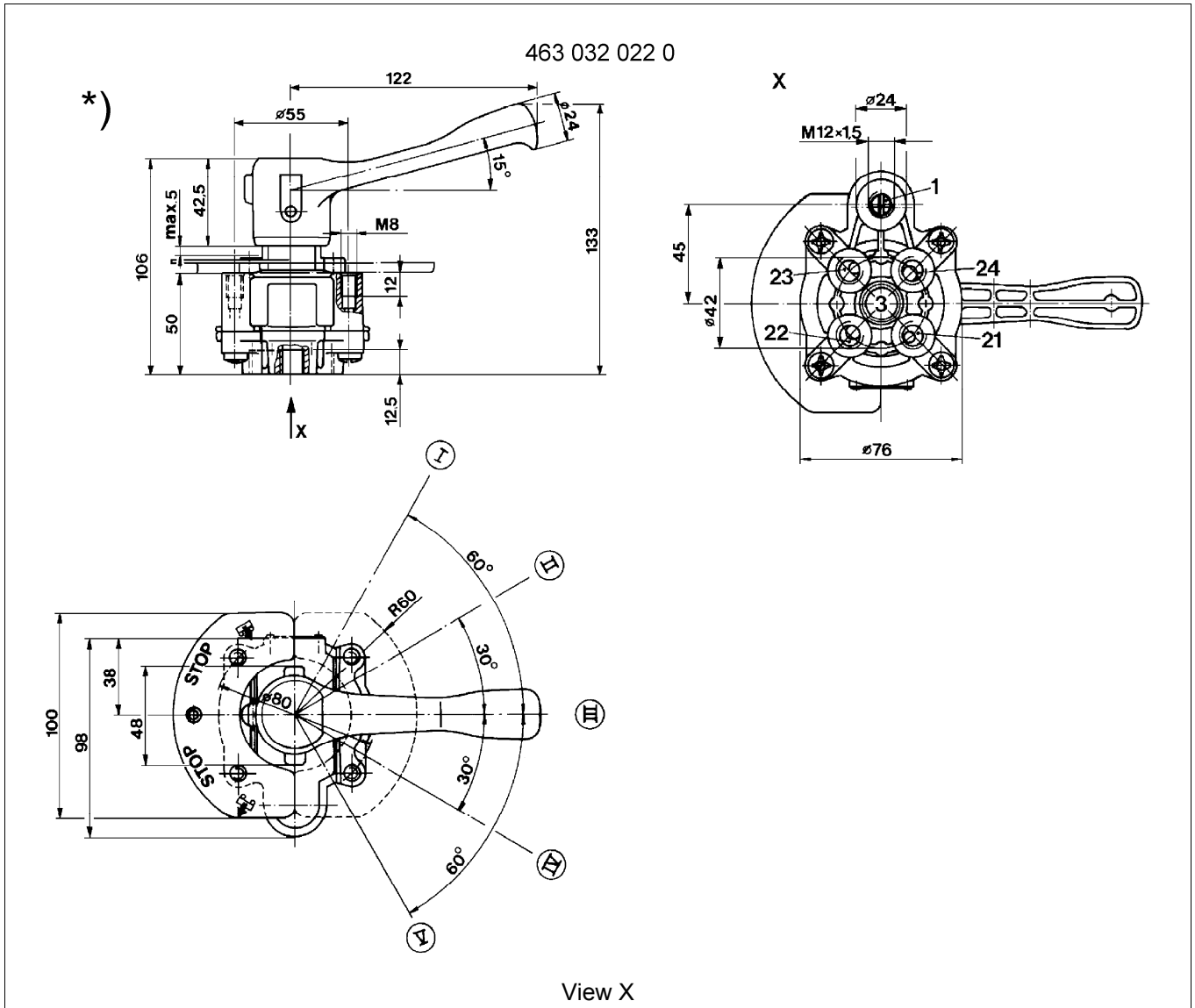

Connections			Key			
1	Supply	3	Exhaust	21	Levelling valve	*) Valve marked as closed: By pressing the button down, the blockage is released.
22	Air suspension bellows	23	Levelling valve	24	Air suspension bellows	

Installation dimensions

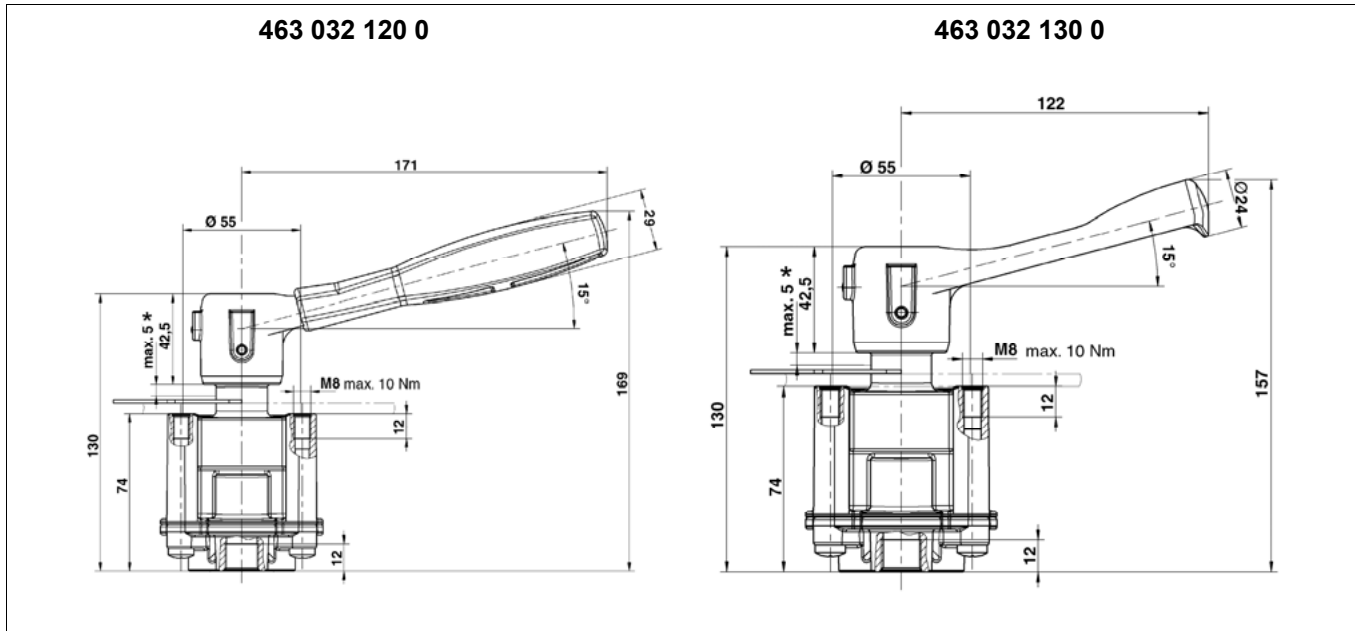

Key

* Stroke for park position

Technical data

Order number	463 032 020 0	463 032 120 0	463 032 130 0	463 032 220 0	463 032 023 0
Max. operating pressure	10 bar	8.5 bar		10 bar	
Nominal diameter	21, 23 = 12.6 mm ² (Ø 4 mm) 22, 24 = 28.3 mm ² (Ø 6 mm) 1, 3 = 63.6 mm ² (Ø 9 mm)				Type single circuit 21 = 12.6 mm ² 22 = 28.3 mm ² 1, 3 = 63.6 mm ²
Port threads	M 12x1.5 -12 deep 1 = M 16x1.5 -12 deep			M 12x1.5 -12 deep 1 = M 16x1.5 -12 deep	M 12x1.5 - 12 deep
Integrated check valve (port 1)	Yes	No		Yes	
Permissible medium	Air				
Thermal range of application	-40 °C to +80 °C				
Max. actuation torque	7 Nm	9 Nm		7 Nm	7 Nm
Weight	1.4 kg	1.5 kg		1.4 kg	1.4 kg
Quickfit connections	–	–	–	5x Ø8x1	–

5.15 3/2-way valve 463 036



Application

Multiple applications in compressed air systems.
Switching connected devices on and off manually.

Purpose

Alternating the connections for operational lines (devices) with the pressure line or the venting line, whereby the valve is seated in both positions.

Maintenance

Special maintenance that extends beyond the legally specified inspections is not required.

Installation recommendation

- Install the 3/2-way valve in the pipe line system so that the vent 3 points downward.
- Fasten the 3/2-way valve on a console (hole Ø 28) with counternut M 28x1.5.

Installation dimensions

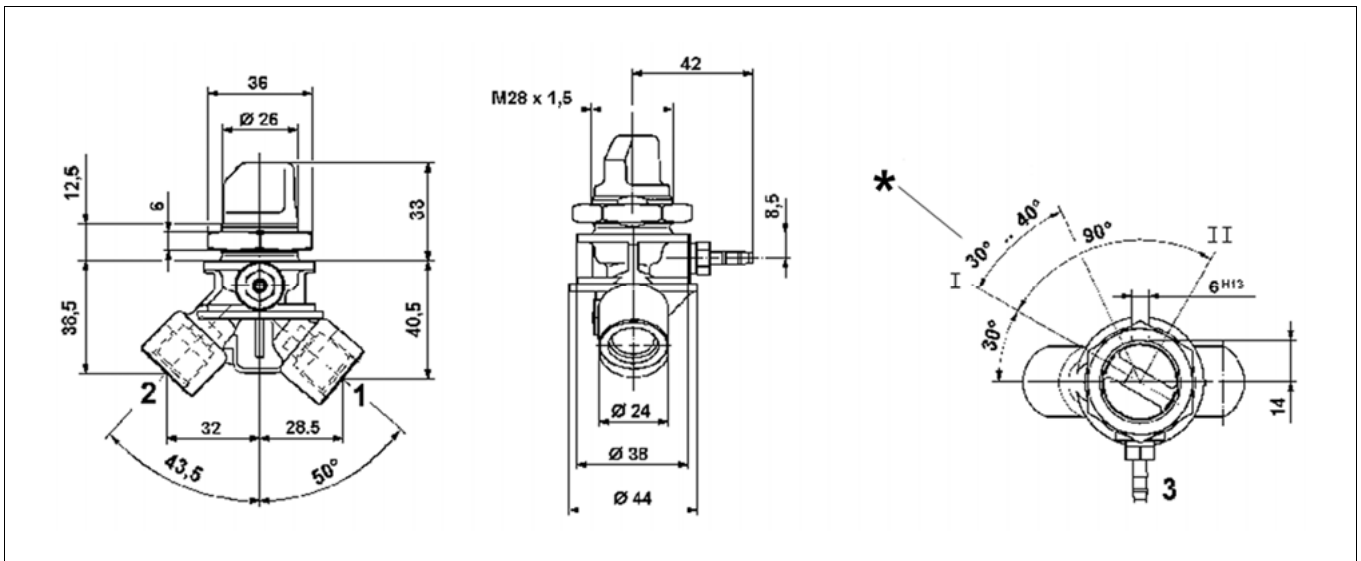

Connections			Key				
1	Energy supply	2	Energy delivery	3	Exhaust	*	Ventilation begin

Technical data

Order number	463 036 016 0
Max. operating pressure	10 bar
Port threads	M 16x1.5 - 12 deep for VOSS-plug connection
Nominal diameter	4 mm
Permissible medium	Air
Thermal range of application	-40 °C to +80 °C
Weight	0.25 kg

5.16 Lift axle control valve 463 084

2-circuit lift axle control valve 463 084 0.. 0



Application

Semitrailer or drawbar trailer with lift axle
Control conventional or via ECAS / Trailer EBS

Purpose

The lifting axle compact valve is in charge of lowering or raising the lifting axle(s) manually and again automatically, as soon as the axle(s) that are down have reached their maximum permissible load.

Maintenance

Special maintenance that extends beyond the legally specified inspections is not required.

Installation recommendation

- Fasten the lift axle control valve using the three stud bolts M6 (**A** = tightening torque 10 Nm) or with two bolts M8 (**B** = tightening torque 20 Nm), see following figure "Installation position".
The unit is equipped with 9 mm holes for mounting.

Mounting position

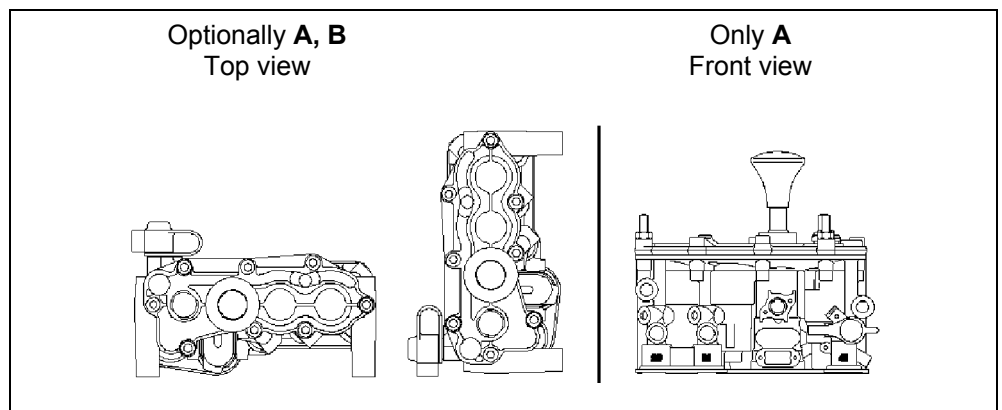

Installation dimensions

463 084 000 0

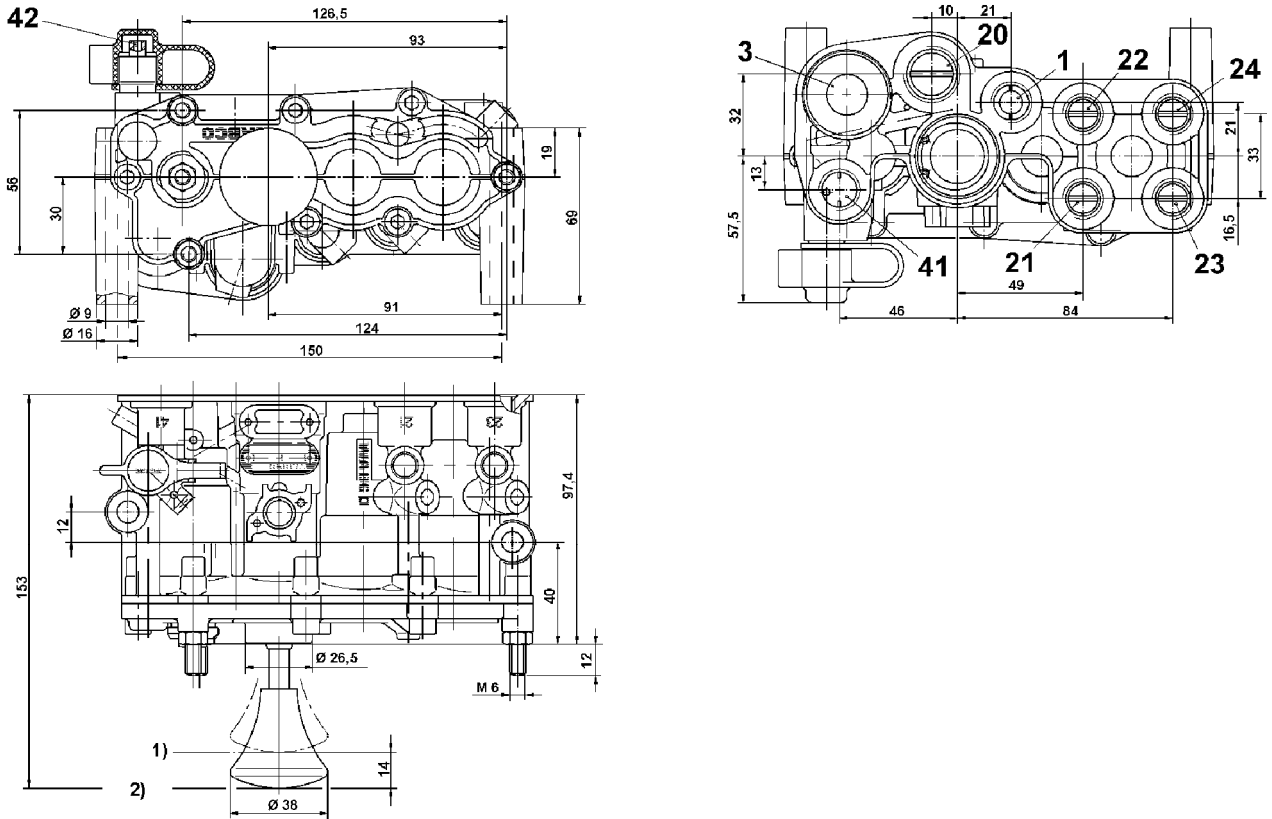

Key			
1)	Lift	2)	Lowering

Connections		Port threads	
1	Supply	3	Exhaust
20	Port lifting bag	1, 21, 22, 23, 24, 41	M 16x1.5
22, 24	Air-suspension bellows "Lift axle"	20	M 22x1.5
42	Test valve for setting the switching pressures	21, 23	Air-suspension bellows "Vehicle"
		41	Damping volume
		42	M 16x1.5 (ISO 3583)

Installation dimensions

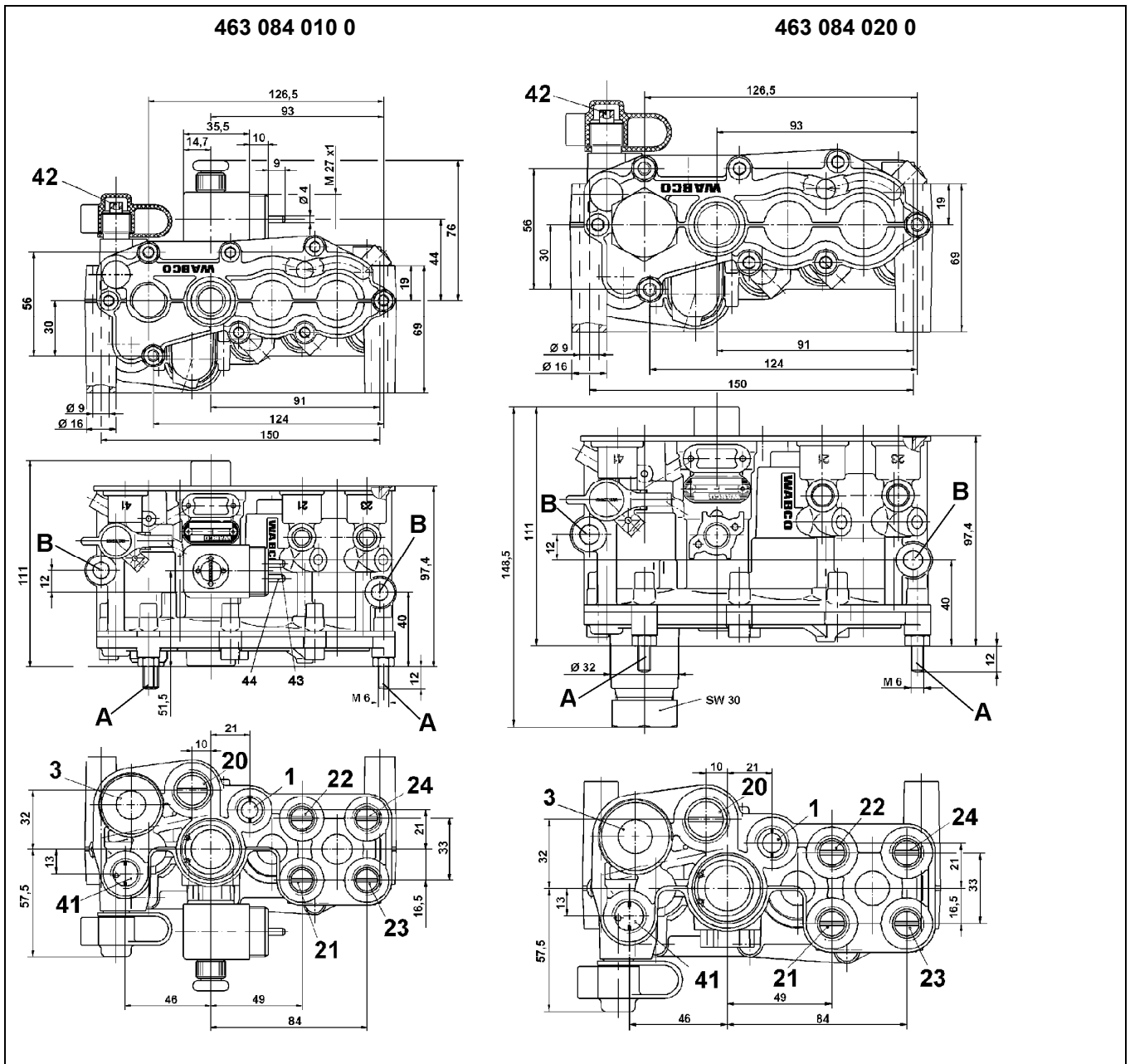

Key

A	Stud bolt	B	Bolt
----------	-----------	----------	------

Connections		Port threads	
1	Supply	3	Exhaust
20	Port lifting bag	1, 21, 22, 23, 24, 41	M 16x1.5
22, 24	Air-suspension bellows "Lift axle"	21, 23	Air-suspension bellows "Vehicle"
42	Test valve for setting the switching pressures	20	M 22x1.5
		41	Damping volume
		42	M 16x1.5 (ISO 3583)

Setting instructions

After the valve has been installed according to the fixing instruction and the scheme, the adjustment of the switch pressure has to be made.



Circuit diagrams

Open the WABCO website www.wabco-auto.com.

Click on *Product Catalogue INFORM* => *Product number*.

Enter the number of the desired circuit diagram into the search field.

Click the *Start* button.

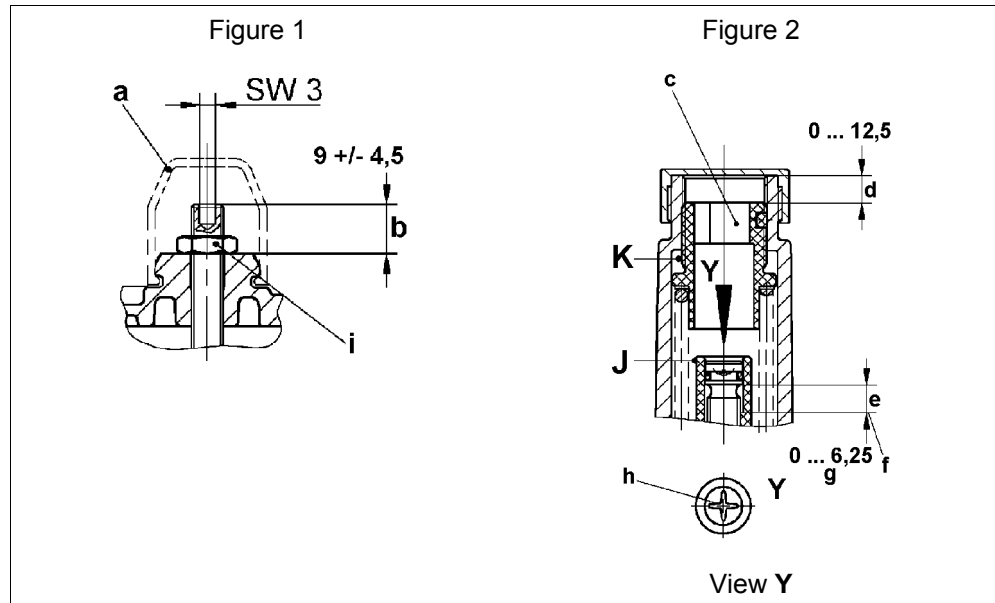

Key

a	Provided cap	b	Range of adjustment	c	Wrench size 12 / M = max. 15 Nm
d	Lowering	e	Lift	f	Stop
g	corresponds with 5 full turns	h	Size 2 / M = max. 1.5 Nm	i	Wrench size 10 / M = 4 ± 1 Nm

Mechanically actuated lift axle control valve 463 084 000 0

See circuit diagram 841 801 448 0 and section "Functionality"

- Press the actuation button (a).
- Set the switch pressure for lowering the lifting axle according to the pressure, at which it is made sure, that the permissible axle load is not exceeded. This is done by connecting a test hose with pressure gauge and pressure reduction valve with test connection 42.
 - ➔ The compressed air flows via duct (f) into chamber B. By increasing the pressure of the test hose the switching point on which the actuation button springs out is detected, port 20 is getting pressureless (lifting axle lowers) and the air supply of the bellows on the lifting axle sets in.
- You can change the switching pressure with set screws: If the switching pressure is too high, turn the screw outward; if the switching pressure is too low, turn the screw inward.

While checking the test pressure always has to be increased starting from 0 bar to switch off the hysteresis.

- When the setting is completed successfully, counter-lock the adjustment screw and cover it with the provided cap.

Electrically actuated lift axle control valve 463 084 010 0

See circuit diagram 841 801 447 0 and section "Functionality"

- Connect pressure switch 441 042 000 0 (set-range 1.0 to 5.0 bar) according to the circuit diagram.
- Set the pressure switch in the same way as the mechanically actuated lift axle control valve.

Fully automatic pneumatic lift axle control valve 463 084 020 0

See circuit diagram 841 801 449 0 and section "Functionality"

Two switching pressures must be set.

- First remove the protective cap with an SW 30 spanner (M = 45 ±5 Nm).
- Thread the Philips screw J (Size 2) inward to the stop (see figure 2).
- Set the switching pressure for lowering the lift axle (screw K) with an Allen key 12 mm the same as the version that is actuated mechanically (see figure 2).
- Set the switching pressure for automatic lifting using a Philips screwdriver (size 2). This requires lowering the test pressure of 8.0 bar again.
 - ➔ The pressure difference of the switch pressures for the automatic lowering and raising has to be 0.4 bar higher than the difference in pressures for the air suspension bellows between lifted and non-lifted axle.

Technical data

Order number	463 084 000 0	463 084 010 0	463 084 020 0
Max. operating pressure	13 bar		
Actuation	mechanical	electric	pneumatic
Nominal diameter	7 mm		
Permissible medium	Air		
Thermal range of application	-40 °C to +80 °C		
Switching pressure setting "lowering"	2.5 to 7 bar	–	2.5 to 7 bar
Adjusted switch pressure	4 ±0.2 bar	–	Lowering 4.5 ±0.2 bar Raising 2.5 ±0.2 bar
Adjustable hysteresis	–	–	1.5 to 4 bar
Voltage	–	24 V ^{+6 V} _{–4.4 V}	–
Current	–	Direct current	–
Nominal current	–	IN = 0.22 A	–
Weight	2.3 kg		

Order numbers	463 084 000 0	463 084 010 0	463 084 020 0
Vehicle is loaded	Automatic lowering	Automatic lowering	Automatic lowering
Vehicle is unloaded	Raise with button press	Electric raising	Automatic raising

Single circuit lift axle compact valve (spring-returned) 463 084 031 0**Application**

Semitrailer or drawbar trailer with lift axle Control via ECAS or Trailer EBS Because of the single-circuit, only suitable for rigid trailer axles.

Purpose

The conventional lifting axle valve series (spring-returned) has been expanded with the single-circuit variant. One lifting axle is actuated automatically depending on the axle load. The "Traction help" function can also be actuated by the Trailer EBS or Trailer ECAS depending on the current axle load. This variant can be used on rigid axles, for which the support bellows can be connected pneumatically for the left and right vehicle sides. Here the specifications of the axle manufacturer must be observed.

Installation dimensions

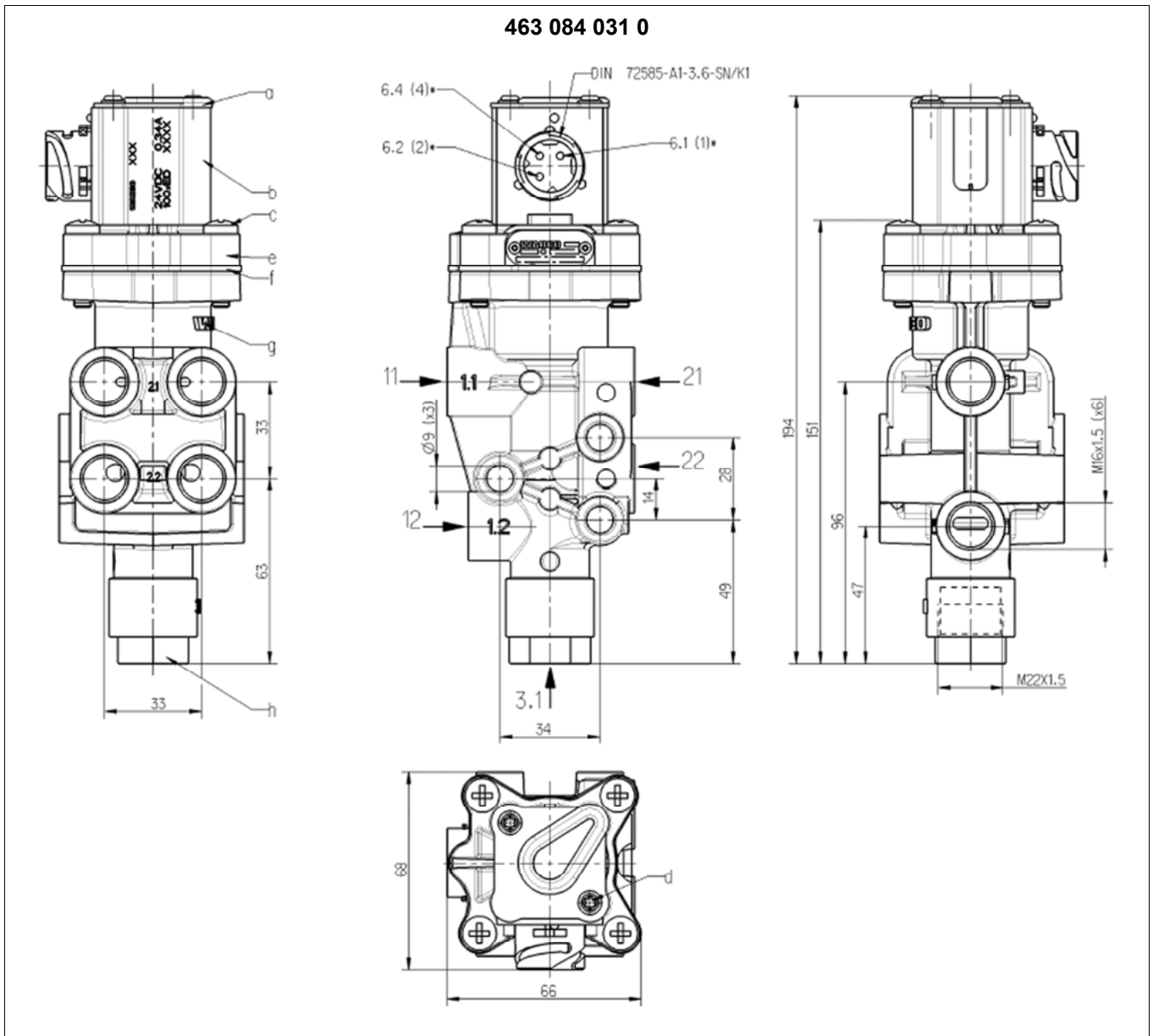

Connections		Port threads					
11	Supply	12	Air-suspension bellows "Vehicle"	21	Port lifting bag	11, 12, 21, 22	M 16x1.5
22	Air-suspension bellows "Lift axle"	31, 32	Exhaust				

Technical data

Order number	463 084 031 0	463 084 041 0	463 084 042 0
Max. operating pressure	13 bar		
Nominal diameter	Ø 8 mm		
Permissible medium	Air		
Thermal range of application	-40 °C to +80 °C	-40 °C to +65 °C	
Voltage	24 V +6 V/-6 V		
Current	Direct current		
Nominal current	IN = 0.22 A		
Weight	0.9 kg		
Quickfit connections	–	4x Ø8x1	3x Ø8x1 1x Ø12x1.5



The electrical connection to the Trailer EBS or ECAS is made via system cables, see Cable Overview or ECAS System Description/EBS System Description for more information.

Open the WABCO website www.wabco-auto.com.

Click on *Product Catalogue INFORM* => *Index*.

Enter *EBS*, *ECAS* or *Overview*.

Click the *Start* button.

Two-circuit lift axle control valve (pulse-controlled) 463 084 100 0**Application**

Semitrailer or drawbar trailer with lift axle. Control via Trailer EBS and ECAS. Enables Traction Help, dynamic wheelbase control and immobilizer functionality.

Purpose

With pulse-controlled valves, a special lifting axle actuation is possible, e.g. the lift axle can be kept in the raised position after the ignition is switched OFF. This is not possible using spring-returned lift axle valves.

Technical data

Order number	463 084 100 0
Max. operating pressure	13 bar
Nominal diameter	Connection 1, 21, 22 (ø 10 mm) Connection 23, 24, 25 (ø 8 mm) Connection 32 (ø 8.7 mm)
Permissible medium	Air
Thermal range of application	-40 °C to +65 °C
Voltage	24 ^{+6 V} _{-4.4 V}
Current	Direct current
Nominal current	IN ≤ 0.34 A
Weight	2.3 kg

5.17 TASC – Return-to-Ride valve 463 090

**Application**

For air-suspension commercial vehicles with Trailer ABS or Trailer EBS.

Purpose

TASC can be used to raise and lower the vehicle – in the same way as with a rotary slide valve. The chassis is also automatically returned to normal driving level as soon as the vehicle starts driving (RTR – Return-To-Ride).

The raising/lowering process is started by simply turning the handle right or left. To halt this process the handle is moved back into the stop position. The system keeps the chassis at the set level.

TASC can be operated in combination with or without levelling valve with height limitation. TASC can be connected directly if levelling valves with height limitation are used. This avoids the bellows being permanently connected to the air reservoir at the upper stop position.

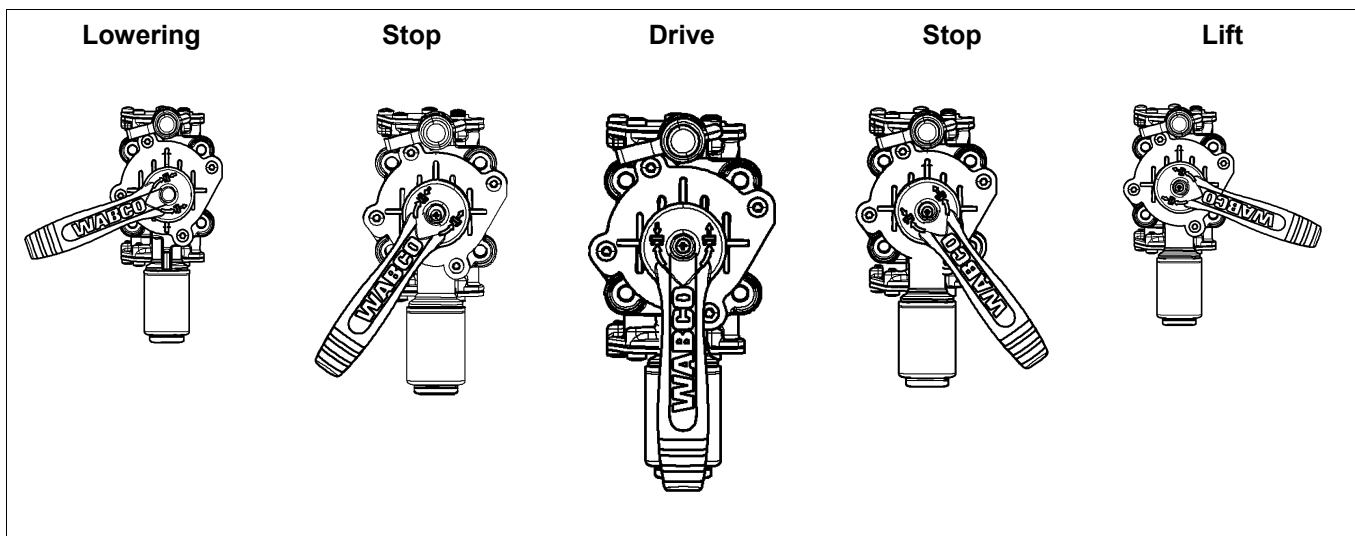
Handle positions

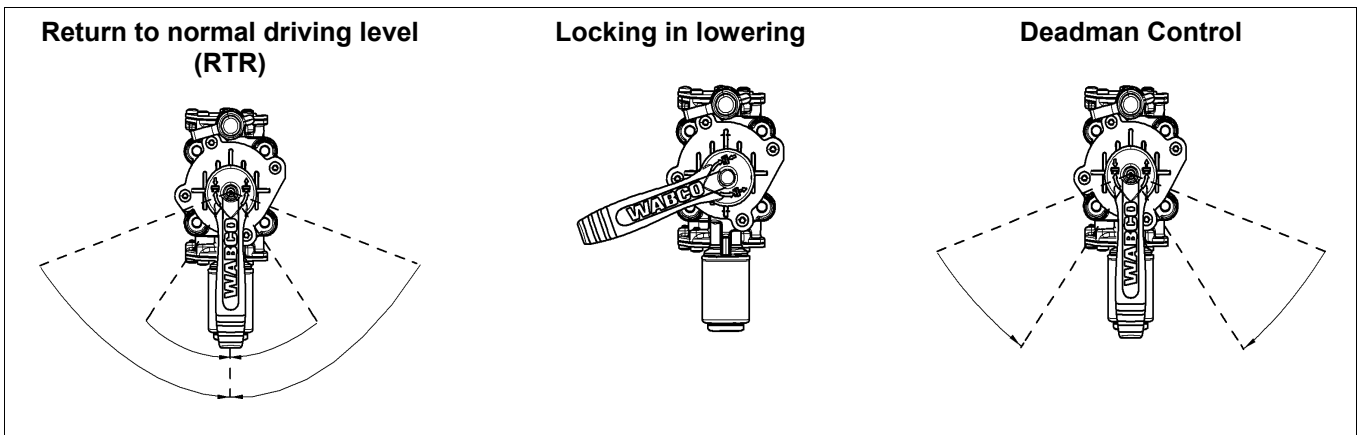

Maintenance

Special maintenance that extends beyond the legally specified inspections is not required.

Installation

TASC can be fitted to the operating panel on the trailer.

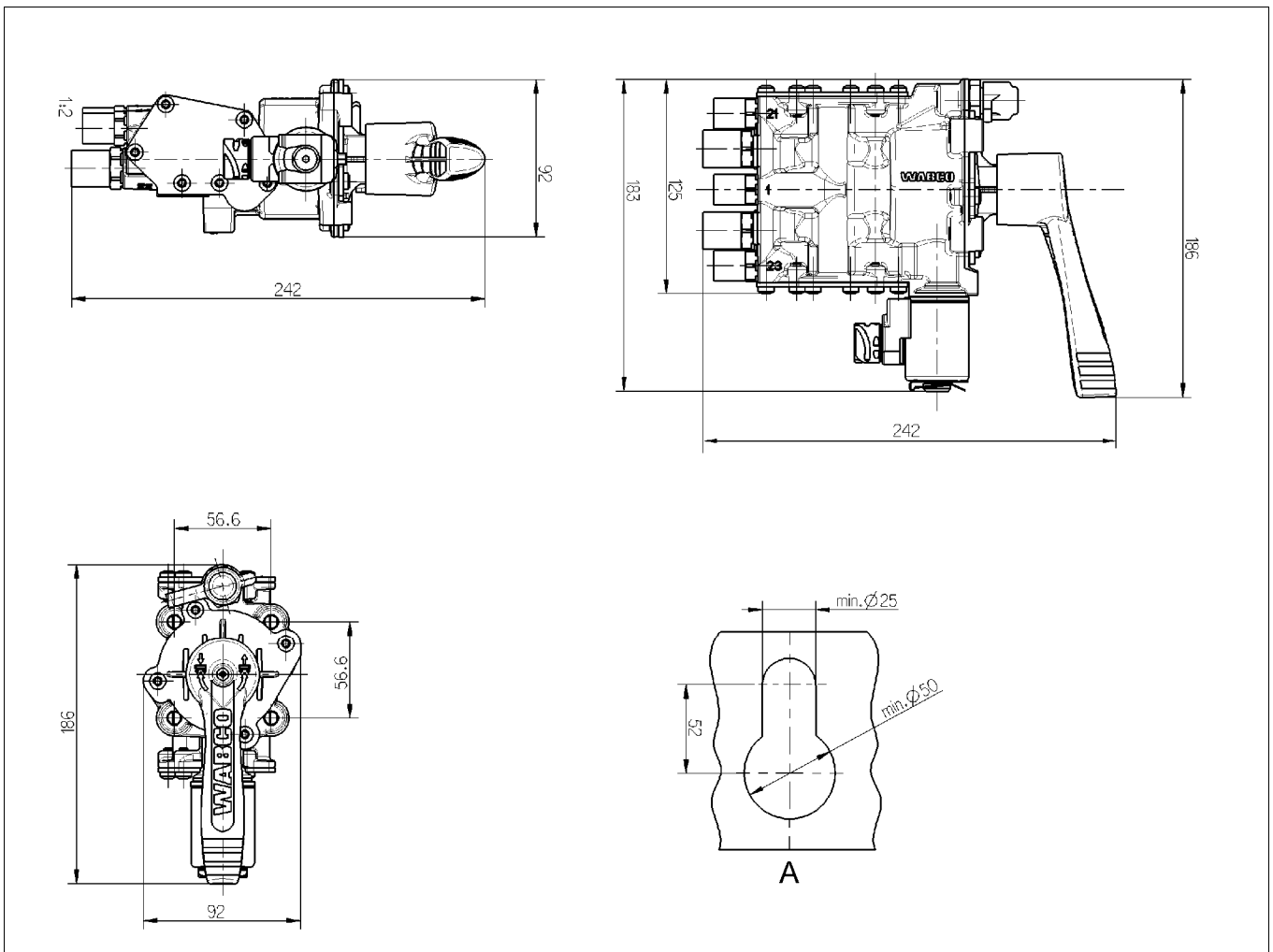

Depending on the clearance, the unit can be rotated through 90° on installation. The TASC handle can then be turned accordingly so it is easy for the user to operate.

**Electrical connection**

TASC with Return-to-Ride is controlled by a speed pulse from the ABS-/EBS system. Retrofitting TASC (when replacing a rotary slide valve or similar product) may require a diagnostic tool as well as training for the new system. One of the cables listed below is required for WABCO systems.

Cable	System	Length
449 623 XXX 0	VCS II	6 m/6 m; 10 m/10 m
449 435 030 0	EBS D	3 m
449 443 XXX 0	EBS E	0.8 m; 1 m; 2 m; 4 m; 6 m; 10 m

Technical data

Part number	463 090 020 0 Dual circuit	463 090 021 0 Dual circuit	463 090 023 0 Dual circuit	463 090 123 0* Dual circuit	463 090 012 0 Single circuit
RTR function	x	x	x	x	x
Locking in lowering	x	x	x	–	x
Pneumatic connection	8x1	8x1	M 16x1.5	M 16x1.5	M 16x1.5
Pressure test connection	x	–	–	–	x
Working pressure	3.5 ... 10 bar				
Voltage	18 ... 32 V				
Thermal range of application	-40 ... 65 °C				
Electrical connection	DIN 72585-B1-3.1-Sn/K2 - bayonet				

Key

* Deadman control for vehicles with a stroke exceeding 300 mm

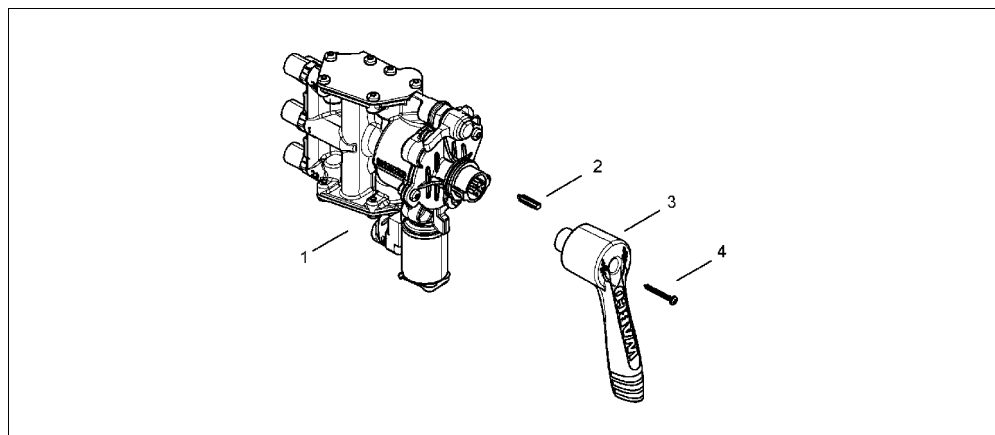
Adjustment of handle to housing**Key**

1	TASC	2	Pin	3	Handle	4	Bolt
---	------	---	-----	---	--------	---	------

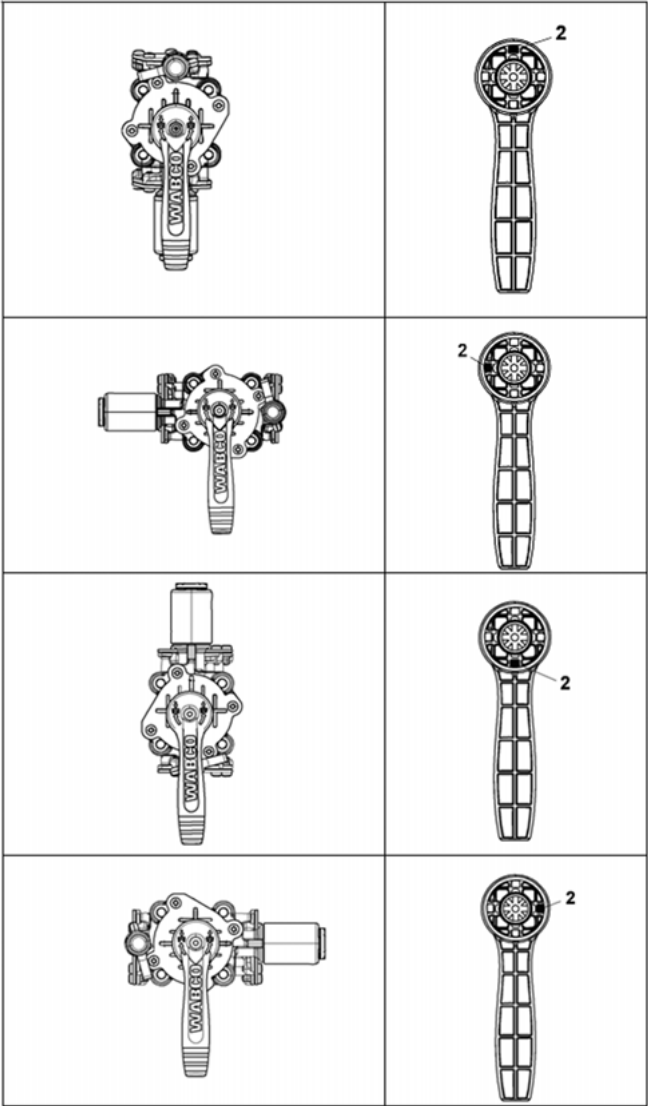

5.18 Damping reservoir 463 084 020 2

Application

Mainly used in combination with the lift axle control valves 463 084 000 0, 463 084 010 0 and 463 084 020 0.

The damping reservoir is a low cost solution since it is directly fitted to port 41 of lifting axle control valves.

Purpose

In order to prevent accidental lowering of the lift axle, if e.g. only because of road irregularities, the switching pressure for lowering the lift axle is achieved briefly, a damping volume is required.

Technical data

Order number	463 084 020 2
Volume	1 dm ³
Ambient temperature	-40 °C to +60 °C
Max. operating pressure	8.5 bar at 60 °C 10 bar at 40 °C
Tightening torque	26 ⁺⁴ Nm
Material	Plastic
Colour	Black
Male stud thread	M 16x1.5
Mounting position	Optional

Installation dimensions

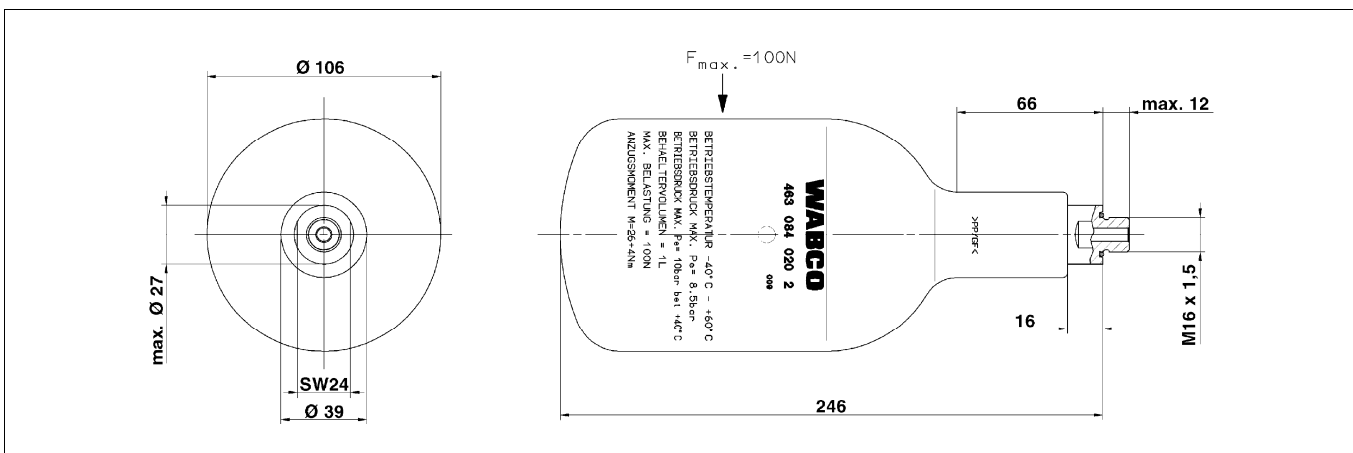

5.19 Test connection 463 703**Application**

All vehicles, can be used on control- and brake-lines.

Purpose

Temporary connection of pressure measurement devices for testing systems or certifying vehicles.

Maintenance

- Check valve (c) regularly for proper closing.

Installation dimensions

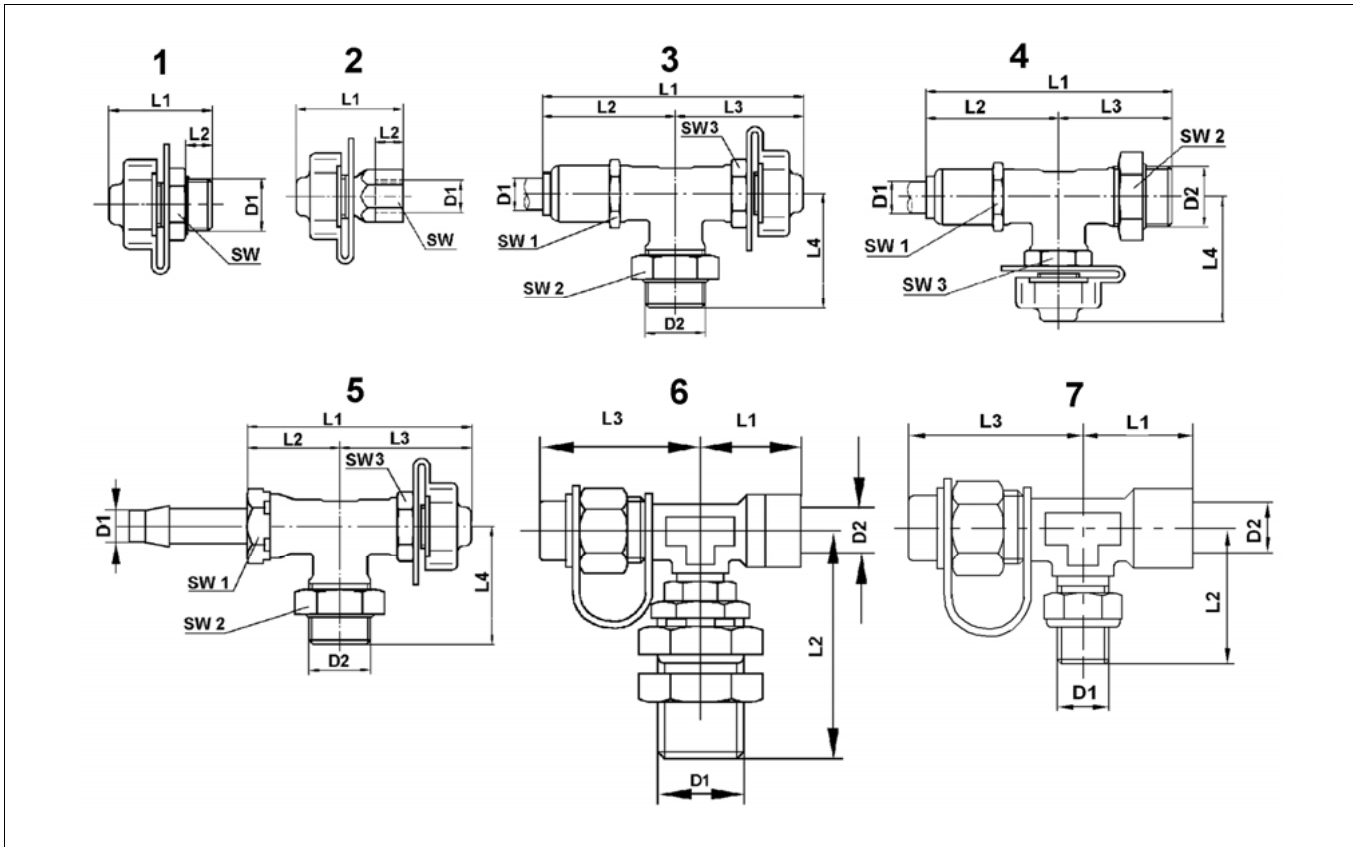

Order number	D1	D2	L1	L2	L3	L4	SW 1	SW 2	SW 3	Fig.
463 700 002 0	M 18x1.5	–	46.3	22.5	–	–	22	–	–	1
463 703 005 0	10x1*	10x1 ¹⁾	60	30	30	49	19	19	17	4
463 703 007 0	12x1.5*	M 12x1.5 ¹⁾	64	32	32	51	22	22	17	4
463 703 024 0	8x1*	M 12x1.5	65	28	33	52	17	17	–	4
463 703 114 0	M 16x1.5	–	36	9	–	–	22	–	–	1
463 703 301 0	12x1.5*	M 22x1.5	96	45	51	42	27	27	17	3
463 703 303 0	M 22x1.5	M 22x1.5	96	42	54	42	27	27	17	3
463 703 306 0	12x1.5*	M 16x1.5	94.5	33	61.5	37	22	22	17	3
463 705 103 0	M 22x1.5	–	36	10	–	–	27	–	–	1
463 703 316 0	3/8"-18 NPTF	–	45	14	–	–	19	–	–	1
463 703 995 0	M 12x1.5	–	43	7	–	–	17	–	–	2
463 705 105 0	M 16x1.5, 1:16 Coned	–	36	10	–	–	17	–	–	1

Key

* Outer diameter x wall thickness

5.20 Levelling valve 464 006



Application

Vehicles with conventionally controlled air-suspension.

Purpose

Control of a constant ride height of the chassis by charging the air-suspension while compressing (loading the vehicle) and by venting when releasing.

The height measurement is done via the angle of the lever and linkage connected with the axle.

Height limitation: The levelling valves 464 006 100 0, 464 006 101 0 and 464 006 201 0 have an additional 3/2-way valve that closes as of a certain adjustable lever angle and switches to a venting function upon actuating the lever again. This "Height limitation" prevents the vehicle from being raised above a permitted level with the rotary slide valve.

Zero point adjustment: The ride height can be adapted to special application conditions of the vehicle with an operating cylinder integrated in the linkage.

Maintenance

Special maintenance that extends beyond the legally specified inspections is not required.

Installation dimensions

464 006 002 0

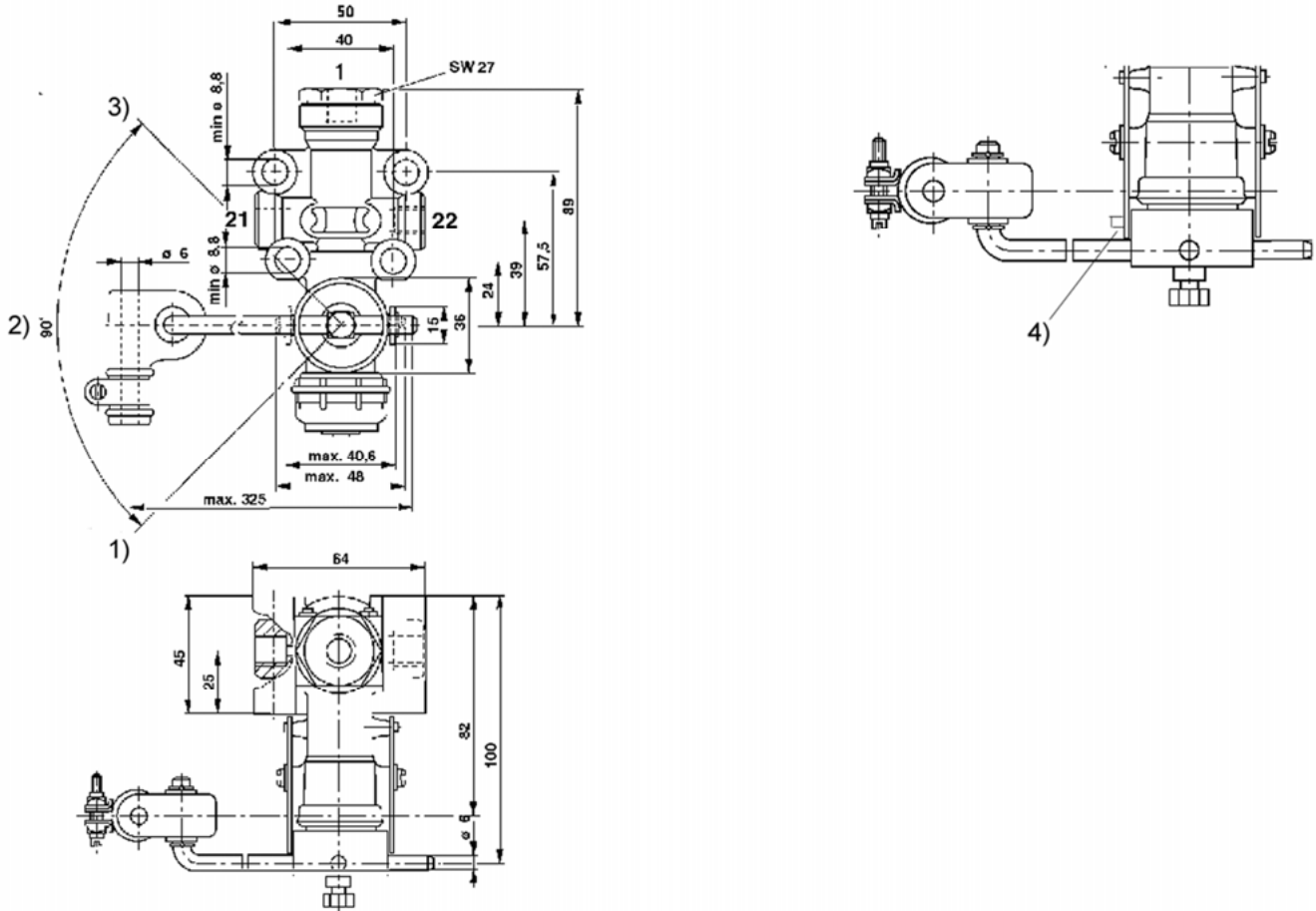

Key			
1) Vent	2) Operating range	3) Charge	4) Fixing the valve in end position with ≥ 7 bar supply pressure and ≤ 3 bar bel-lows pressure with $\varnothing 3h8$ or parallel pin $\varnothing 3h8 \times 24$ DIN 7

Connections		Port threads	
1	Energy supply (Reservoir)	3	Exhaust
21/22	Energy delivery (Air suspension bellows)		
		M 12x1.5 - 12 deep	

Installation dimensions

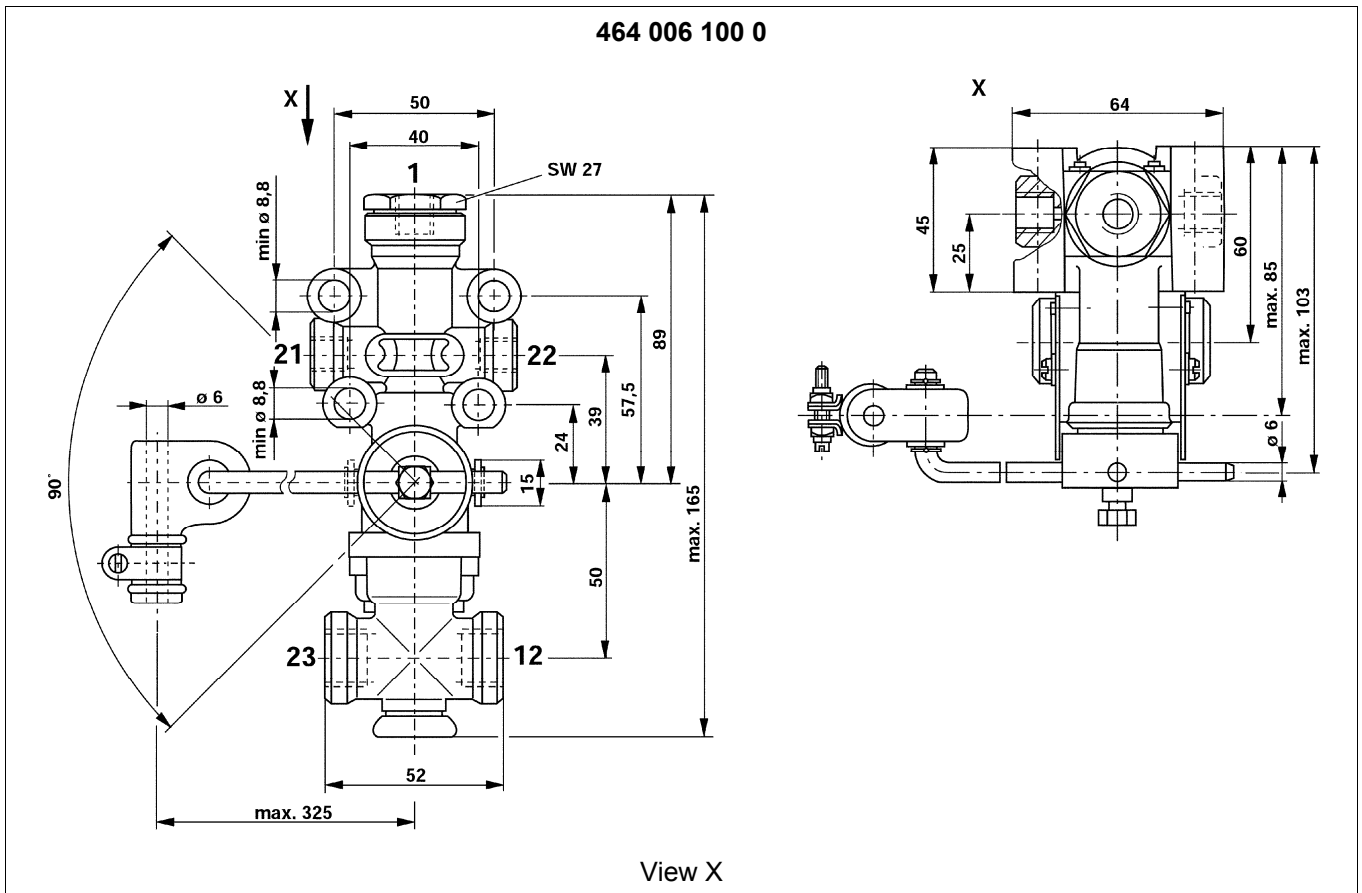

Connections			Port threads	
1	Energy supply (Reservoir)	3 Exhaust	12 Energy supply (Supply)	1, 21, 22 M 12x1.5 - 12 deep
21/22	Energy delivery (Air suspension bellows)	23 Energy delivery (Rotary slide valve)		12, 23 M 16x1.5

Levelling valve 464 006 ... 0 – Linkage 433 401 003 0

The linkage 433 401 003 0 must be ordered separately.

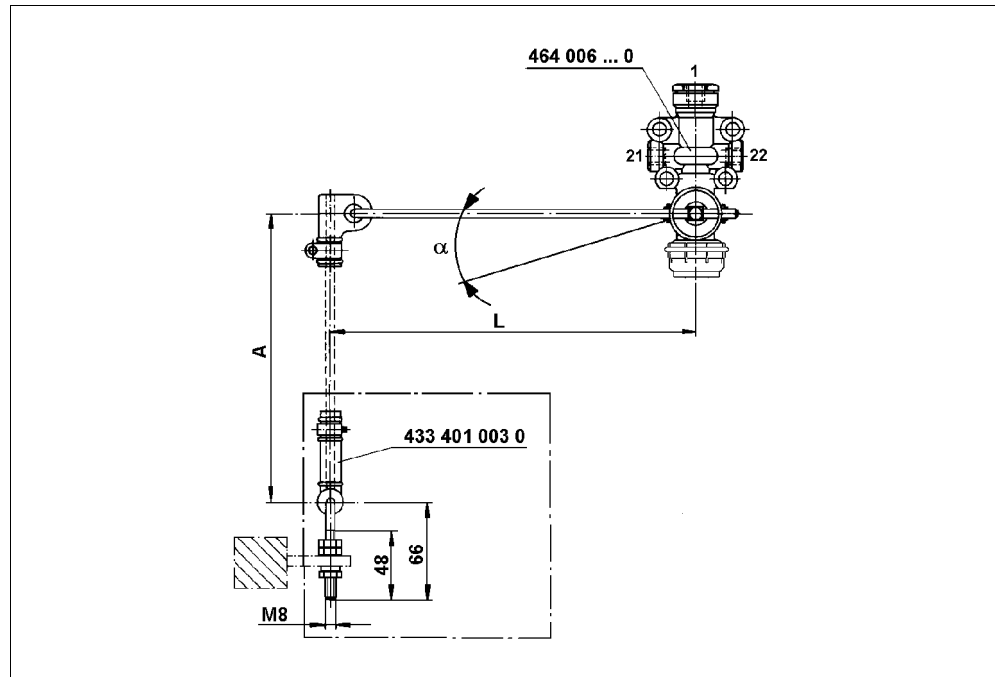
**Key**

α Deflection of the levelling valve lever max. 45°.

A A is the dimension between axle mounting point and the connection to the levelling valve lever (α -character).

L Lever length (at least 150 mm)

For adjusting the valve at the vehicle it is decisive which total spring travel the axle permits.

Approximate value:

The ratio "lever length L / rod length A" should be ≤ 1.2 if the closing angle of maximum 45° is not exceeded.

The lever length L should be 150 to 295 mm. If a shorter lever has to be used, then the air consumption of the levelling valve is higher.

Installation recommendation and setting information

- Fasten the levelling valve vertically or horizontally with two M8 bolts on the chassis.
The drain must point downwards.
- To make installation and setting of the lever and linkage easier, you can insert a $\varnothing 3h8$ locator pin or a $\varnothing 3h8 \times 24$ DIN 7 parallel pin into neutral position to position the air-suspension valve shaft (see previous installation dimensions).
- Install the linkage if the vehicle is positioned at normal level.
➔ The linkage has to be aligned vertically.
- Mount the levelling valve at maximum lever length if possible.
- You can clamp the lever at the desired length with the hexagon head bolt seated on the fastener for the round bar.
Depending on the fitting position various cranks of the lever are possible.
- By accordingly fixing or turning the lever for 180° the levelling valve can be optionally operated from right or left.

- Depending on the final installation position - vertical or horizontal - the lever is to be inserted through one of the two bores in the operating shaft which are offset by 90° to one another.
The levelling valve 464 006 100 0 is set to a closing angle of 30° ±2° in the factory.
The setting adjustments lie between 15° and 45°. A closing angle of < 15° is not permitted.

! Note the adjustment data of the vehicle manufacturer when replacing.

- For adjustment of the closing angle the rubber plug underneath the 3/2-Directional Control Valve has to be removed to adjust the adjusting screw with a Torx T30 screwdriver:
Counterclockwise means a reduction of the closing angle, clockwise means an increase. One rotation means an approx. 13° angle change.
The following table can be used to define the height increase of the vehicle up to shutting the supply air off to the rotary slide valve as a function of the closing angle and for determining the lever length.
- After the vehicle has been lowered to its buffers with the help of a rotary slide valve, measure the height of the chassis.
- Then raise the chassis with the rotary slide valve.
→ If the permissible full suspension travel is achieved before the height limitation of the levelling valve is applied, cancel the raising process and lower the vehicle.
Turning the set screw counterclockwise reduces the closing angle and also the suspension travel. If the height limitation sets in before the chassis is at the required hub height, the vehicle has to be lowered slightly as well in this case.
Turning the self-locking set screw clockwise increases the closing angle and the suspension travel.
Repeat the process until the required suspension travel (equal or less than the maximum suspension travel specified by the axle manufacturer) is achieved.

Adjustment values

Lever length L [mm]	Hub height H [mm]					
	α = 15°	α = 20°	α = 25°	α = 30°	α = 35°	α = 45°
125	32	43	53	62	72	88
150	39	51	63	75	86	106
175	45	60	74	87	100	124
200	52	68	84	100	115	141
225	58	77	95	112	129	159
250	65	85	106	125	143	177
275	71	94	116	137	158	194
295	76	101	125	147	169	209

Hub height H [mm]	Lever length L [mm]					
	$\alpha = 15^\circ$	$\alpha = 20^\circ$	$\alpha = 25^\circ$	$\alpha = 30^\circ$	$\alpha = 35^\circ$	$\alpha = 45^\circ$
50	193	146	118	100	87	71
60	232	176	142	120	105	85
70	271	205	166	140	122	99
80	309	234	189	160	140	113
90		263	213	180	157	127
100		293	237	200	174	141
110			260	220	192	156
120			284	240	209	170
130			308	260	227	184
140				280	244	198
150				300	262	212
160					279	226
170					297	241
180						255
190						269
200						283

Technical data

Order number	464 006 002 0	464 006 100 0	464 006 101 0	464 006 102 0	464 006 201 0
3/2 directional control valve	No	Yes	Yes	No	Yes
Max. operating pressure	13 bar				
Max. dynamic bellows pressure	15 bar				
Permissible medium	Air				
Thermal range of application	-40 °C to +80 °C				
Linkage	Round bar \varnothing 6 mm				
Nominal width Levelling valve	2x \varnothing 3 mm				
Nominal width Shut-off valve	–	\varnothing 6 mm	–	–	–
Weight	0.41 kg	0.51 kg	0.51 kg	0.53 kg	0.70 kg
Quickfit connections	–	–	–	5x \varnothing 8x1	5x \varnothing 8x1



For the zero point adjustment on the levelling valve, the following operating cylinders can be used:

421 410 023 0, Hub 25 mm

421 410 054 0, Hub 45 mm

421 411 304 0, Hub 85 mm; with piston rod facing upward, use bellows (Accessories pack 421 411 530 2)

5.21 3/2-way solenoid valve 472 1..

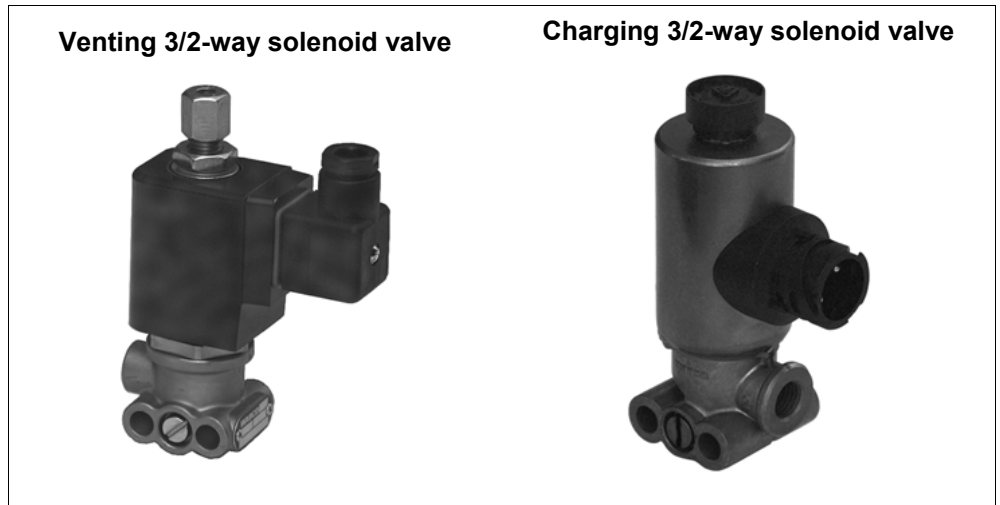

Application

Multiple applications, i.e. controlling operating cylinders.

Purpose

Venting 3/2-way solenoid valve: To vent an air line when current is supplied to the solenoid.
 Charging 3/2-way solenoid valve: To pressurize an air line when current is supplied to the solenoid.

Maintenance

No special maintenance is required.

Installation recommendation

- Install the 3/2 way valve in any position.
- Fasten the 3/2 way solenoid valve with two M8 bolts.
- If solenoids are used without any protective circuitry, use diode plug 894 101 620 2.

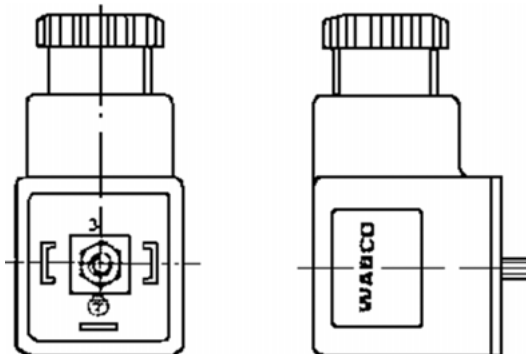

! In trailers which have electronic systems (e.g. ABS, ECAS) fitted, no solenoid valves may be installed without protective wiring if they have the same source of power as the electronics.

Installation dimensions

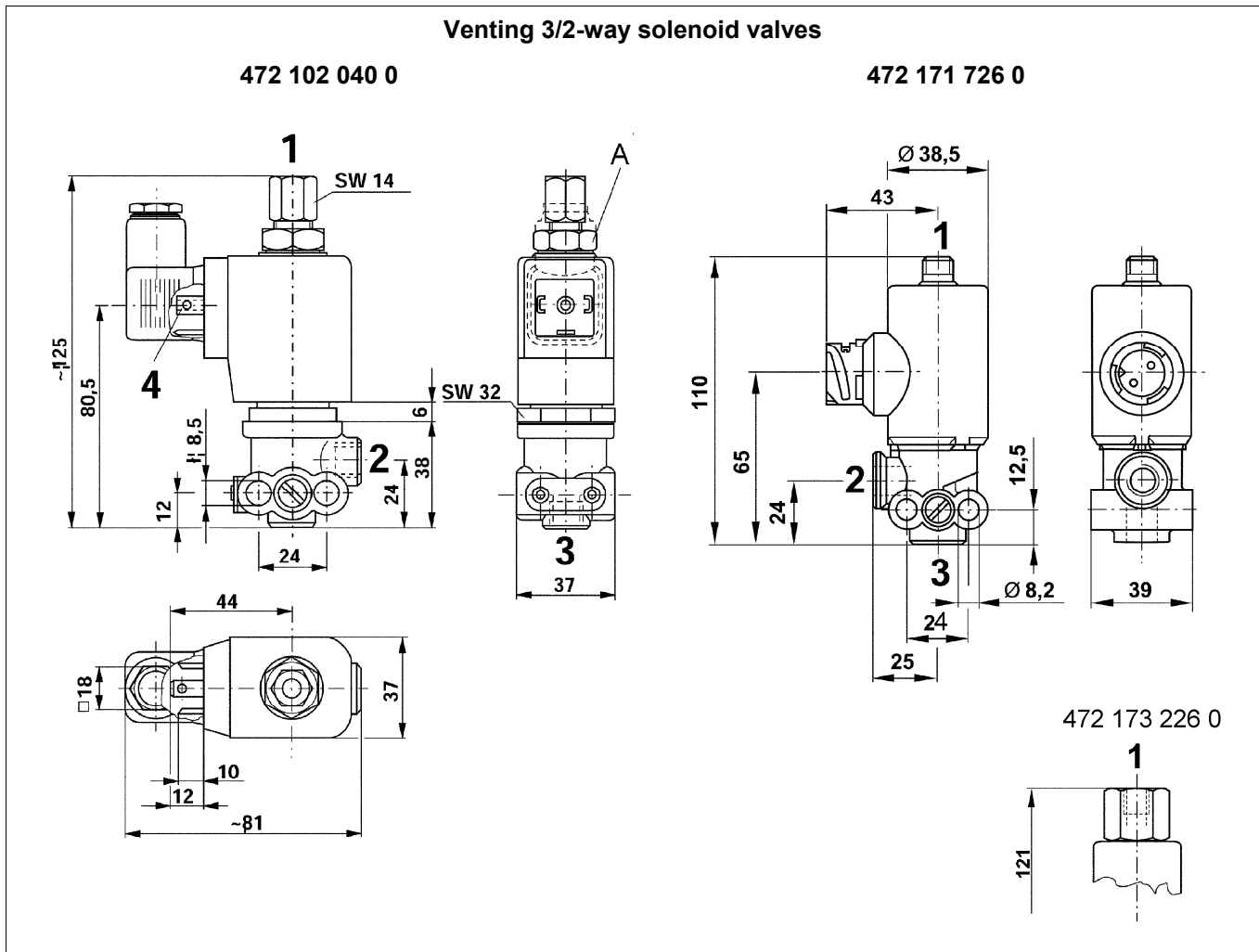

Connections		Key
1	Energy supply	A Loosen the SW 19 hexagon nut to turn the magnets
2	Energy delivery	
3	Exhaust	
4, 6	Electrical control connection	

Charging 3/2-way solenoid valves

472 127 140 0

472 170 606 0

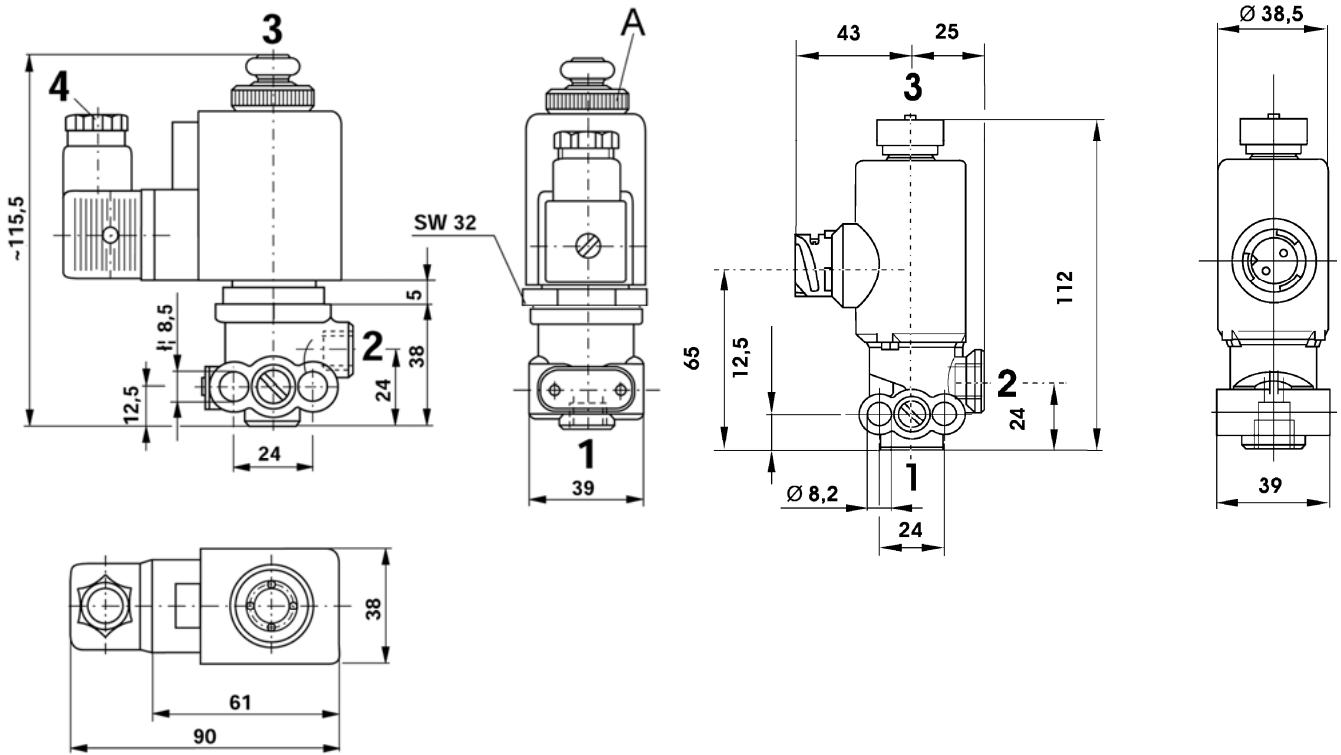

Connections

- 1 Energy supply
- 2 Energy delivery
- 3 Exhaust
- 4, 6 Electrical control connection

Key

- A To turn the magnets, loosen the knurled nut.

Cable with DIN bayonet 449 515 ... 0

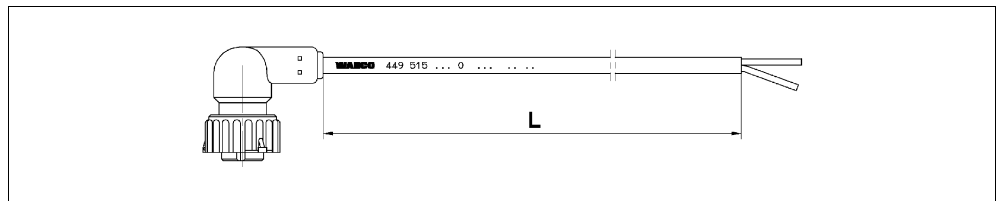

Length (L) on request

Technical data

		Venting 3/2-way solenoid valves				
Order number		472 102 040 0	472 171 700 0	472 171 726 0	472 173 226 0	472 173 700 0
Operating voltage (DC)		10.8 V to 28.8 V	24 ⁺⁸ _{-6.5} V			
Nominal diameter	delivery	Ø 2.6 mm	Ø 2.2 mm		Ø 4 mm	
	Exhaust	Ø 2.2 mm				
Nominal current		at 10.8 V = 0.33 A at 28.8 V = 0.87 A	0.41 A		0.69 A	
Solenoid rating		100 %				
Cut-out voltage		–	< 165 I V		< 180 I V	
Port threads		2, 3 = M 12x1.5 - 10 deep	M 12x1.5	1 = M 12x1.5 - 7 deep 2, 3 = M 12x1.5 - 10 deep	M 12x1.5 - 10 deep	M 12x1.5
Max. operating pressure		8 bar	11 bar			
Permissible medium		Air				
Thermal range of application		-40 °C to +70 °C	-40 °C to +100 °C		-40 °C to +80 °C	
Connector			M 27x1	DIN bayonet		M 27x1
Weight		0.6 kg	0.5 kg			

		Charging 3/2-way solenoid valves				
Order number		472 127 140 0	472 170 600 0	472 170 606 0	472 172 600 0	472 172 626 0
Operating voltage (DC)		10.8 V to 28.8 V	24 V ⁺⁸ _{-6.5}			
Nominal diameter	delivery	Ø 2.2 mm	Ø 4 mm		Ø 2.2 mm	
	Exhaust				Ø 3 mm	
Nominal current		at 12 V = 0.33 A at 24 V = 0.65 A	0.69 A		0.41 A	
Solenoid rating		100 %				
cut-out voltage		–	< 180 I V		< 165 I V	
Port threads		M 12x1.5 - 10 deep	M 12x1.5	M 12x1.5 - 10 deep	M 12x1.5	M 12x1.5 - 10 deep
Max. operating pressure		8.5 bar	10.2 bar	11 bar		
Permissible medium		Air				
Thermal range of application		-40 °C to +70 °C	-40 °C to +80 °C		-40 °C to + 100 °C	
Connector		–	M 27x1	DIN bayonet	M 27x1	DIN bayonet
Weight		0.5 kg				

5.22 Pressure reducing valve 473 301



Application

Multiple applications, e.g. reducing brake pressures on a trailing steering axle.

Purpose

Reducing the input pressure in a certain ratio, and quick venting of the downstream brake unit.

Maintenance

Special maintenance that extends beyond the legally specified inspections is not required.

Installation recommendation

- Install the pressure reducing valve vertically so that the drain 3 points downward.
- Fasten the pressure reduction valve with two M8 bolts.

Installation dimensions

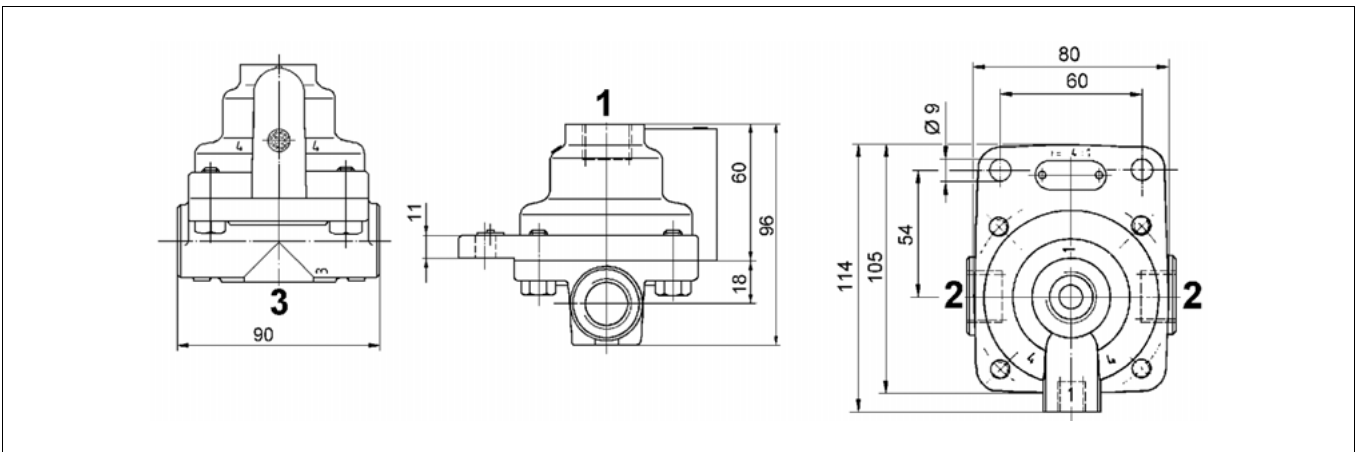

Connections

1	Energy supply	2	Energy delivery	3	Exhaust
---	---------------	---	-----------------	---	---------

Technical data

Order number	473 301 000 0	473 301 001 0	473 301 002 0	473 301 003 0
Pressure reduction ratio	2:1	1.5:1	1.35:1	1.15:1
Port threads	M 22x1.5 - 15 deep			
Max. operating pressure	10 bar			
Permissible medium	Air			
Thermal range of application	-40 °C to +80 °C			
Weight	0.9 kg			

Diagram

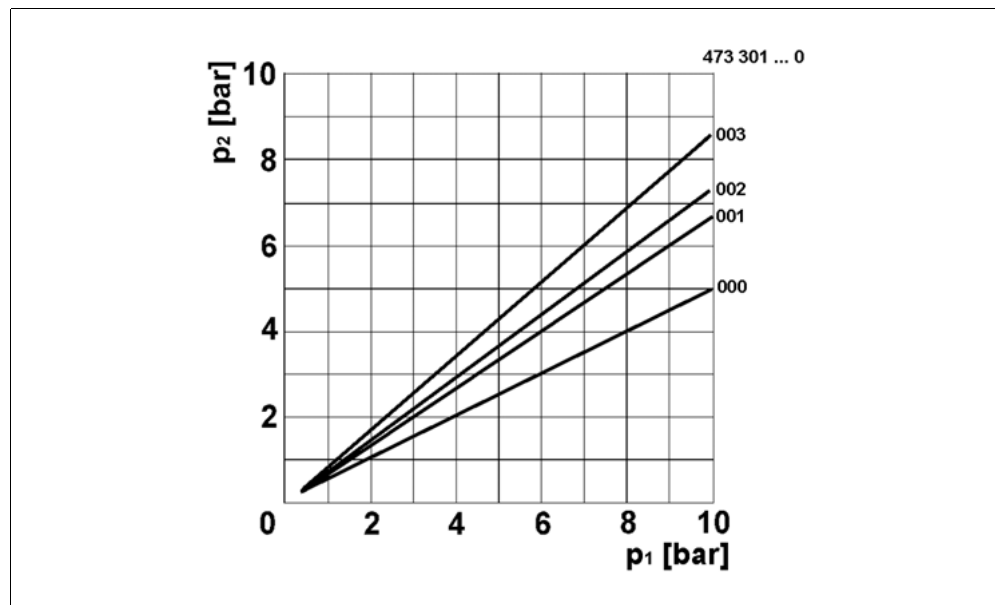

Key

p₁ Output pressurep₂ Input pressure

5.23 Quick release valve 473 501 / 973 500

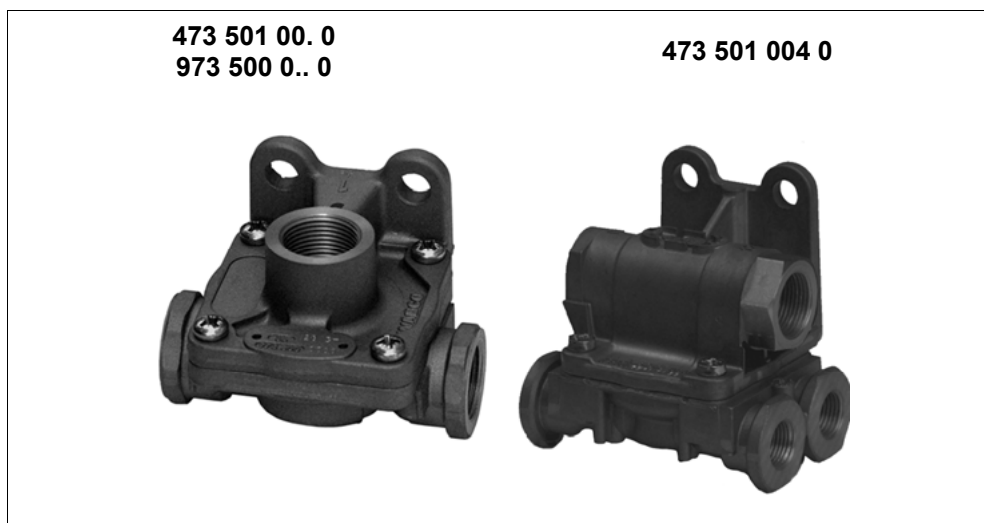
**Application**

Vehicles with long brake lines and large-volume brake cylinders.

Purpose

Rapid evacuation of longer control lines or brake lines and brake cylinders. The brake is therefore released immediately.

Maintenance

Special maintenance that extends beyond the legally specified inspections is not required.

Installation recommendation

- Install the quick release valve so that vent 3 points downward.
- Fasten the quick release valve with two M8 bolts.

Installation dimensions

973 500 000 0

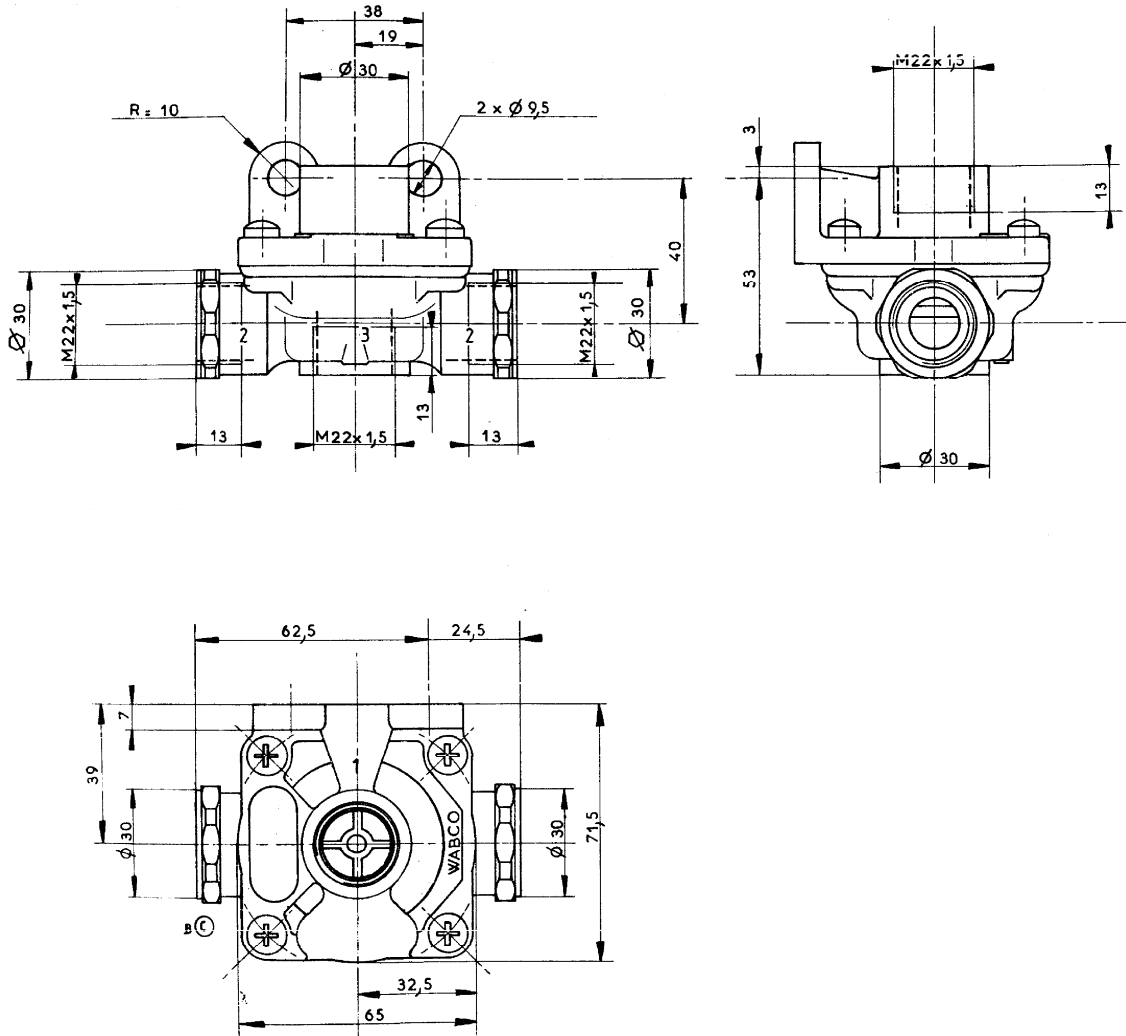

Connections

Port threads

1	Energy supply	2	Energy delivery	3	Exhaust	M 22x1.5 - 13 deep
---	---------------	---	-----------------	---	---------	--------------------

973 500 051 0

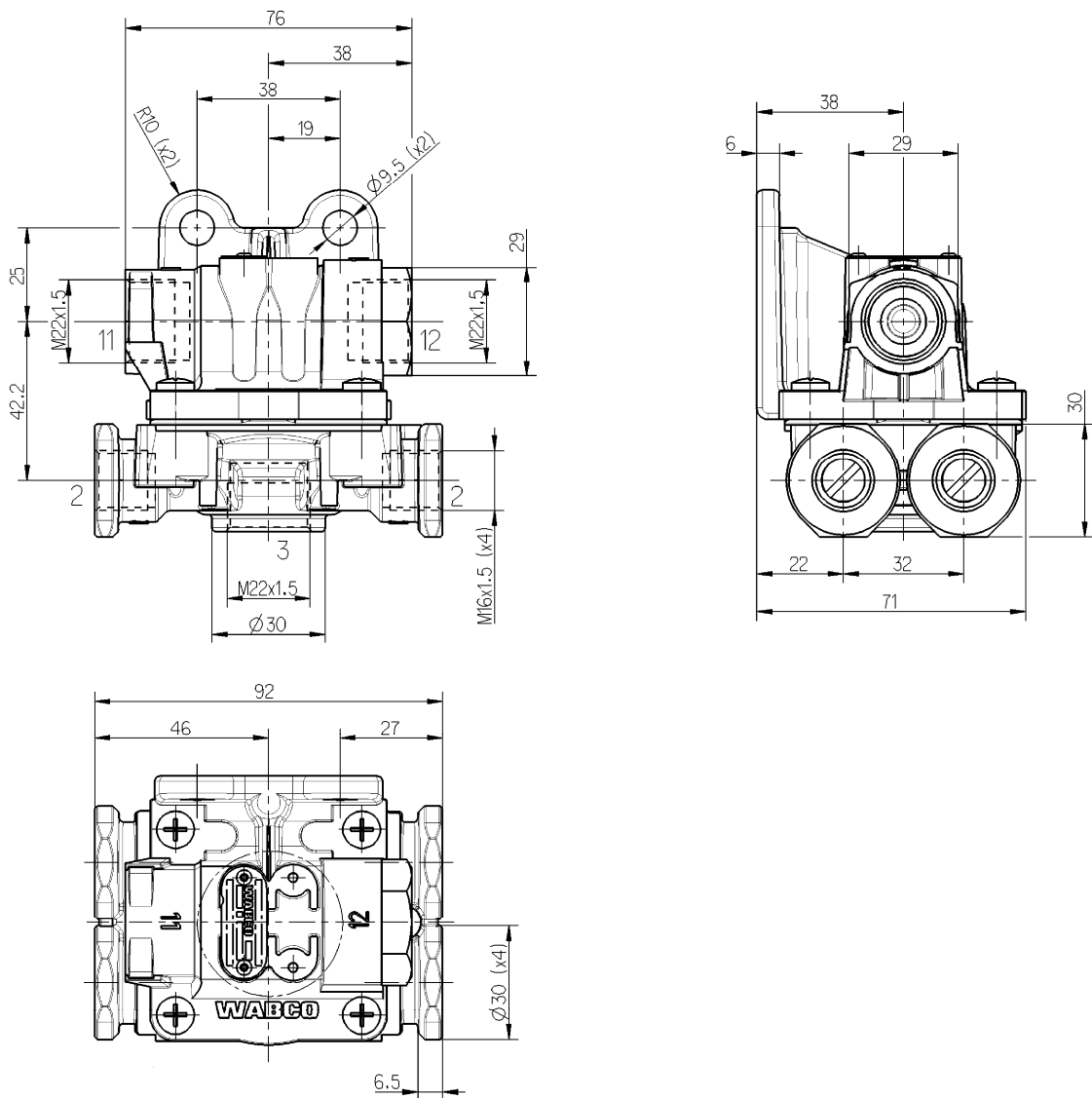

Connections		Port threads			
11, 12	Energy supply	3	Exhaust	3, 11, 12	M 22x1.5 - 13 deep
2	Energy delivery			2	M 16x1.5 - 13 deep

473 501 004 0

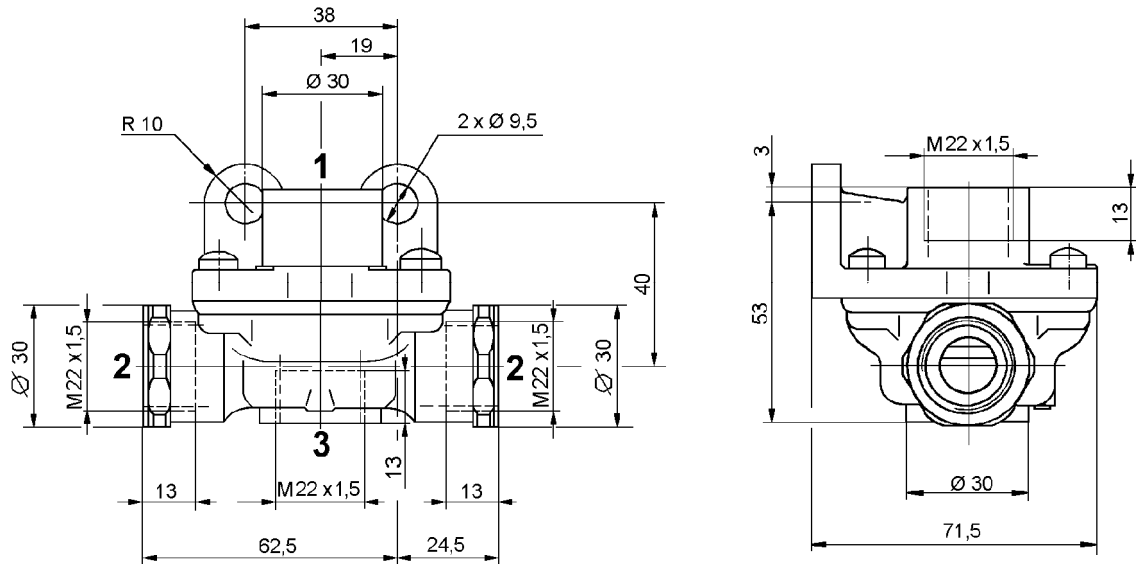

Connections

1 Energy supply

2 Energy delivery

3 Exhaust

Technical data

Order number	473 501 000 0	473 501 001 0	473 501 004 0	973 500 000 0	973 500 051 0
Port 1, 2 with filter	No	No	Yes	No	No
Max. operating pressure	10 bar			12 bar	
Nominal diameter	Ø 14 mm				
Permissible medium	Air				
Thermal range of application	-40 °C to +80 °C				
Weight	0.3 kg			0.43 kg	

5.24 Pressure limiting valve 475 010

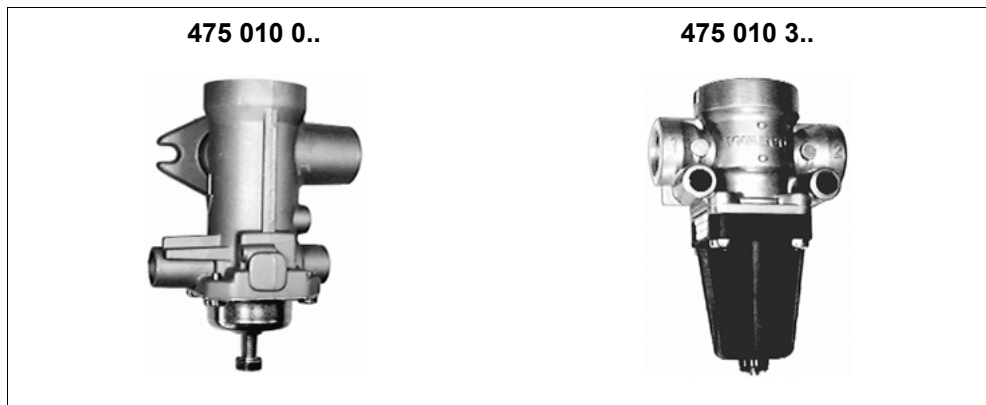

Application

Multiple applications, on a lifting axle e.g. for limiting the pressure on the lift bellows.

Purpose

To limit the output pressure to a set level.

Maintenance

Special maintenance that extends beyond the legally specified inspections is not required.

Installation recommendation

- Install the pressure limit valve vertically so that the vent 3 points downward.
- Fasten the pressure limit valve with two M8 bolts.

Installation dimensions

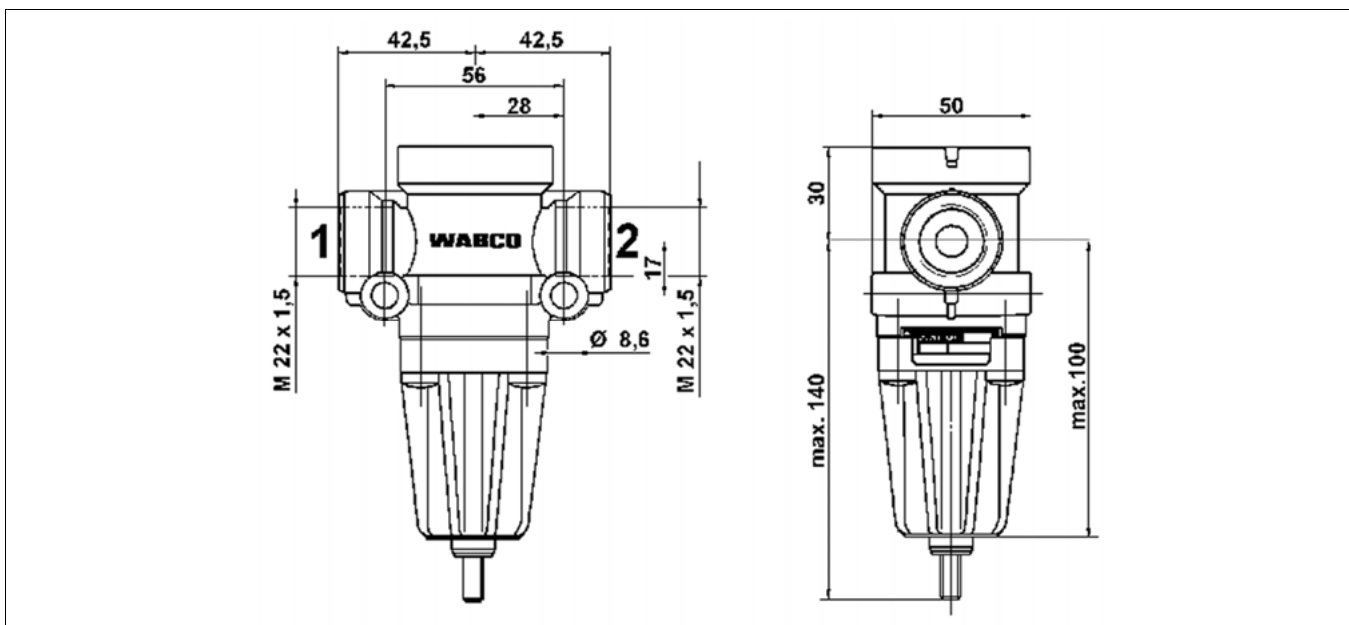

Connections

1	Energy supply	2	Energy delivery	3	Exhaust
---	---------------	---	-----------------	---	---------

Technical data

Max. operating pressure	20 bar
Port threads	M 22x1.5 - min. 12 deep
Permissible medium	Air
Thermal range of application	-40 °C to +80 °C
Weight	0.37 kg

Order number	Input pressure p ₁	Output pressure p ₂	Adjustment range with p ₁ = 7.5 bar
475 010 302 0	7.5 bar	5.3 +0.3 bar	1.5 - 6.0 bar
475 010 303 0		1.8 +0.3 bar	1.5 - 6.0 bar
475 010 305 0		6.0 +0.3 bar	6.0 - 7.5 bar
475 010 309 0		5.7 +0.3 bar	1.5 - 6.0 bar
475 010 310 0		4.0 +0.3 bar	1.5 - 6.0 bar
475 010 312 0		5.5 +0.2 bar	1.5 - 6.0 bar
475 010 313 0		3.3 +0.3 bar	1.5 - 6.0 bar
475 010 307 0	8.0 bar	1.8 +0.3 bar	1.5 - 6.0 bar
475 010 324 0		1.4 +0.3 bar	0.5 - 1.6 bar
475 010 311 0	8.5 bar	3.5 +0.3 bar	1.5 - 6.0 bar

5.25 Automatic load-dependent load sensing valve (LSV) 475 71.

LSV 475 712



Application

LSV controller with integrated trailer brake valve for leaf-spring semitrailers (mainly in Italy, France and the UK)

Purpose

Control of the two-line trailer brake systems when actuating the braking system of the truck.

Automatic control of the braking force based on the charge status of the vehicle with the integrated LSV.

Actuation of the automatic trailer braking with partial or total pressure drop in the supply line.

Maintenance

Special maintenance that extends beyond the legally specified inspections is not required.

Installation recommendation

- Install the LSV vertically so that the drain faces downward.
The set screws on the top of the housing are used for fastening.
For the linkage, use knuckle joint 433 306 003 0 if necessary.
- To determine the lever length L , draw a line in the respective nomograph using the scale for control ratio i (e.g. 2.8) to the scale for spring deflection f (e.g. 30).
➔ Extending this line crosses the scale for lever length L at 140 mm.

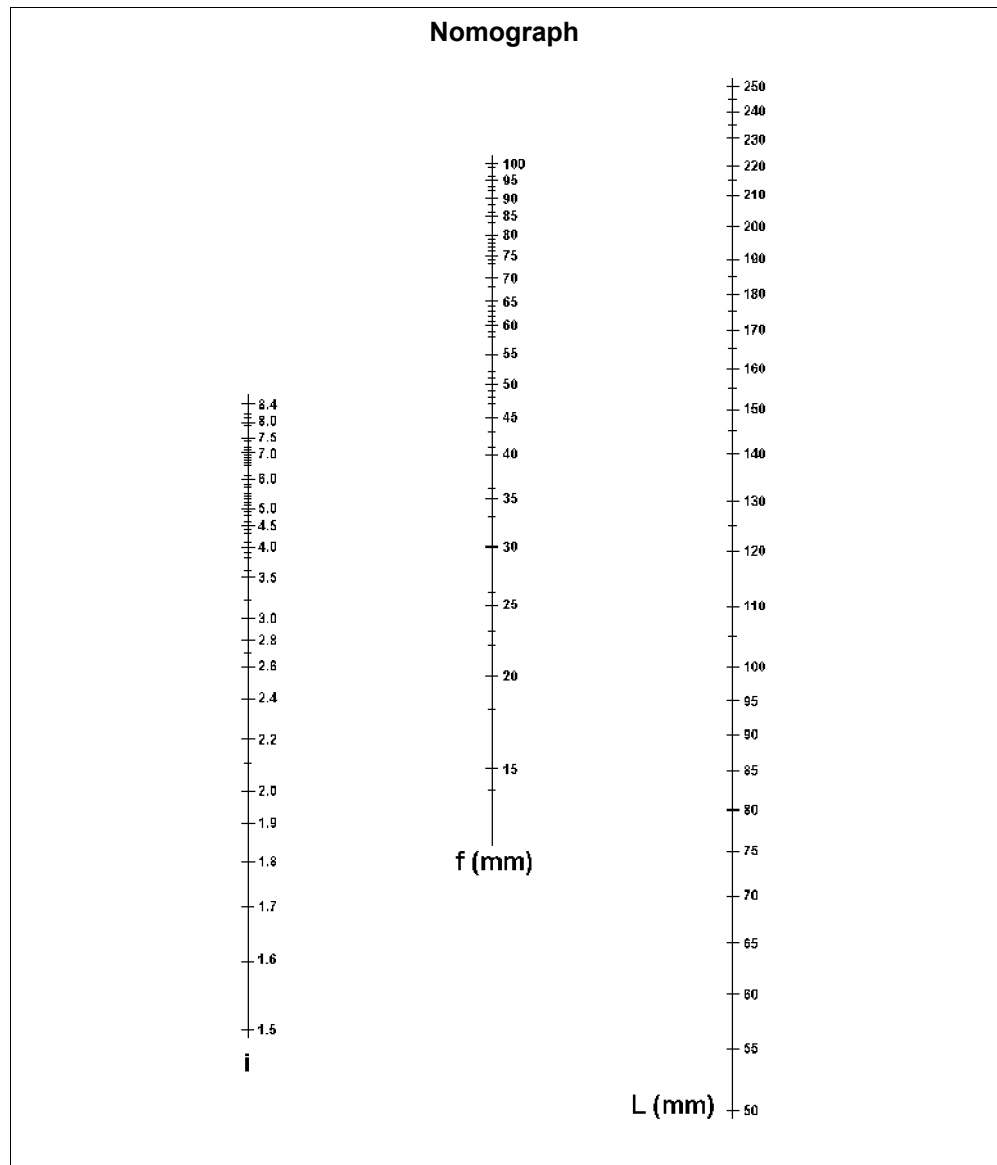

Key		
i	Control ratio = $\frac{p_{on} - 0.8}{p_{off} - 0.5}$	f Spring deflection
		L Lever length

Installation dimensions

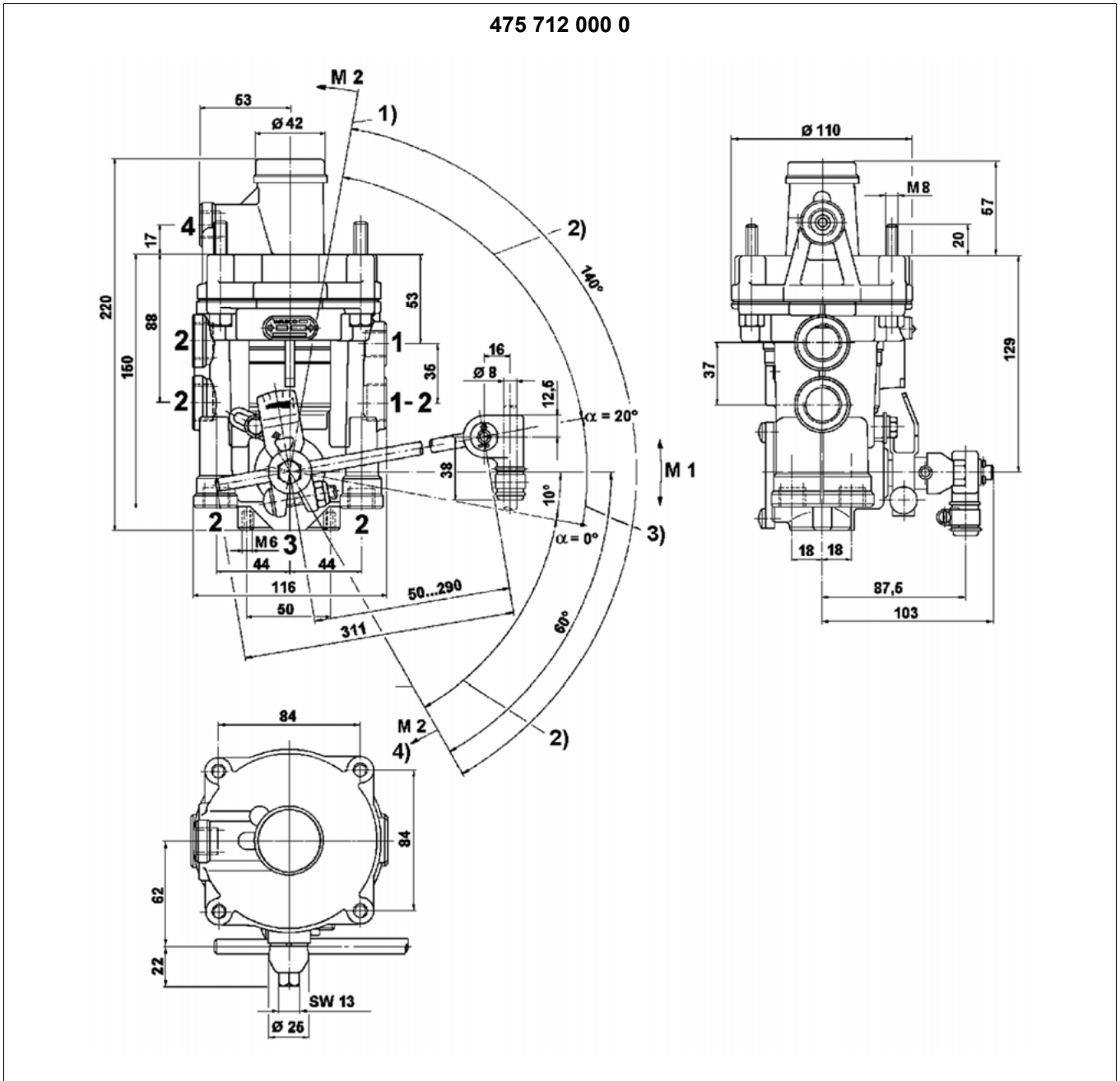

Connections	Port threads	Key
1-2 Energy supply or release (supply reservoir)	1, 4 M 16x1.5 - 12 deep	1) Stop at break of linkage
1 Energy supply	1-2 M 22x1.5 - 13 deep	2) Over travel
2 Energy delivery	2 M 22x1.5 - 13 deep (side)	3) Control stroke
3 Exhaust	2 M 16x1.5 - 122 deep (bottom)	4) Stop
4 Control port		

Technical data

Order number	475 712 000 0	475 712 004 0
Max. operating pressure	10 bar	

Order number	475 712 000 0	475 712 004 0
Control range, dynamic effect	$\alpha = 20^\circ$	$\alpha = 30^\circ$
Usable lever length	50 to 290 mm	50 to 275 mm
Linkage	via linkage (see fig. Installation dimensions).	with integrated knuckle joint, see 475 713
Port 1, 1-2, 4 with filter	–	X
Max. permissible adjustment torque M2	20 Nm	
Thermal range of application	-40 °C to +80 °C	
Weight	2.2 kg	2.6 kg

Pressure diagrams

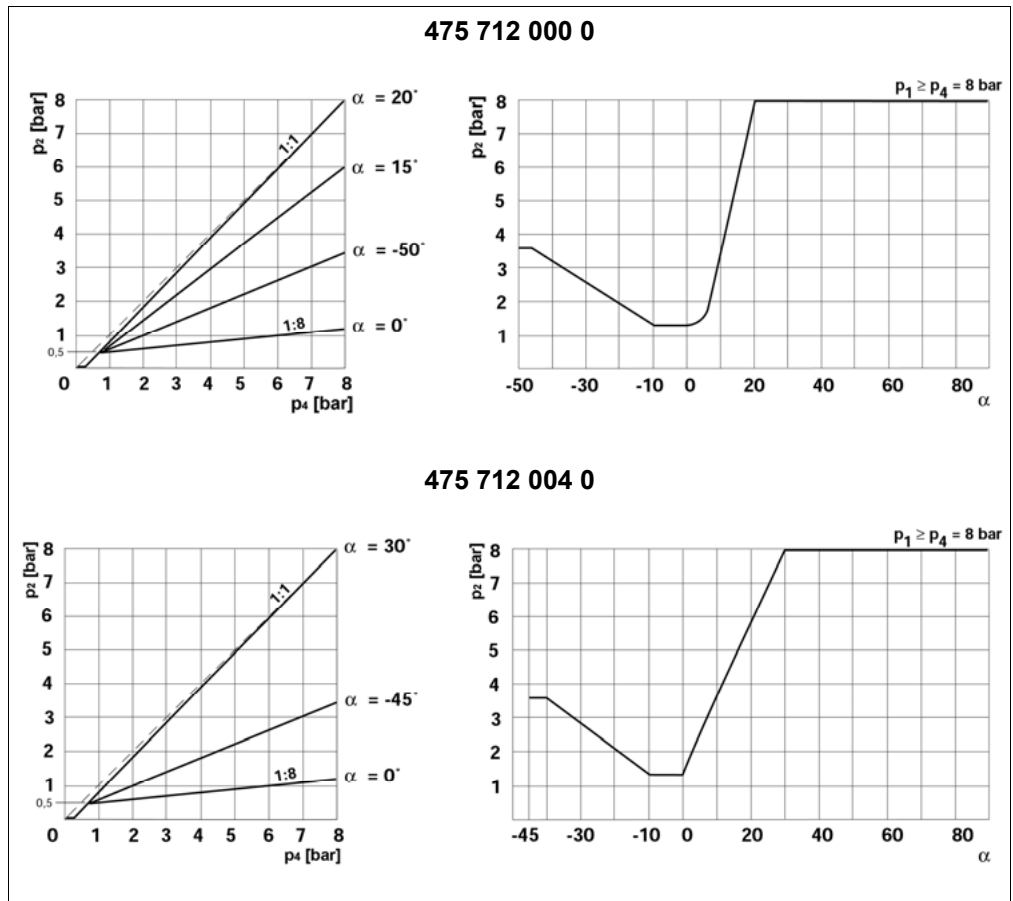

Key			
p_1	Input pressure	p_4	Control pressure
p_2	Output pressure	α	Lever travel [degrees]

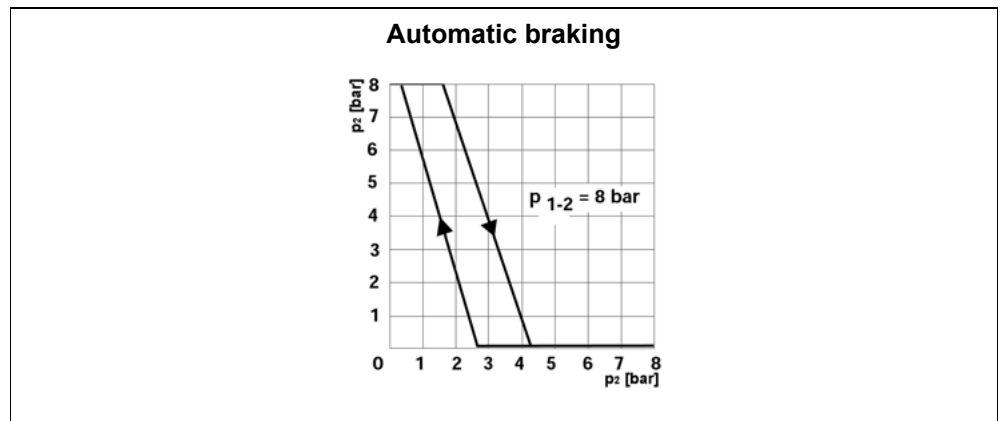

Key			
p_1	Input pressure	p_4	Control pressure
p_2	Output pressure	α	Lever travel [degrees]

LSV 475 713**Application**

Static LSV for mechanical suspension vehicles (single-axles/axle assemblies) without EBS.

With axle assemblies, only in combination with trailer brake valve or relay valve to meet timing requirements in accordance with ECE R13.

Purpose

Automatic control of the braking force in pneumatic brake cylinders depending on the vehicle load.

Installation dimensions

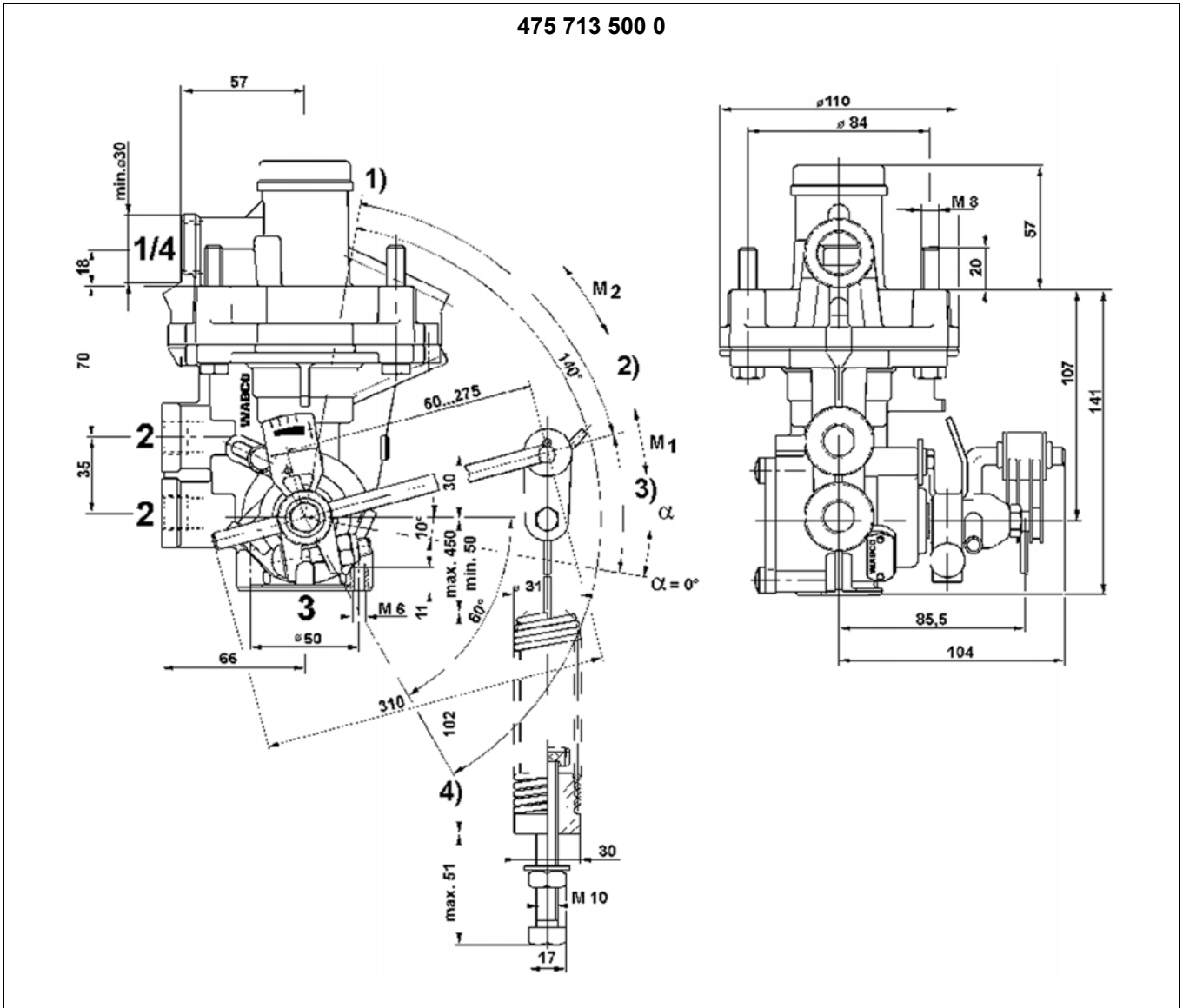

Connections		Port threads		Key	
1/4	Energy supply	1/4	M 22x1.5 - 13 deep	1)	Stop at break of linkage
2	Energy delivery	2	M 16x1.5 - 12 deep	2)	Over travel
3	Exhaust			3)	Control stroke
				4)	Stop

Setting instructions

**Load sensing valve program (LSV)**

The required lever length can be determined with our calculation program instead of with Nomographs as well.

Open the WABCO website www.wabco-auto.com.

Then click on the links *Diagnostics => WABCO System Diagnostics => Download => Load Sensing Valve Program (LSV)*.

The nomographs below are used to determine the LSV lever lengths to be set on the unit. Using an adjustment tool and a \varnothing 3 mm pin, you can set the empty brake pressure at a certain input pressure (e.g. 6 bar) and clamp with the bolt SW 10. Before adjustments can be made on LSV (cable length, lever position, etc.), there is to be no pressure on the LSV.

After fitting the LSV in the vehicle (empty) and the knuckle joint on the axle shaft (In the process, the spring of the knuckle joint has to be prestressed by 15 mm using the fastening bolt) and after tightening and fixing the connecting cable (cable length Min. 50 mm, Max. 450 mm), the connecting cable must hang vertically below its fastening on the lever. When the pin is removed and the LSV is again pressurised, its output pressure must be the LSV unladen pressure.

Make small corrections to the unladen brake pressure by threading the fastening bolt in or out (max. 5 mm). If the empty pressure is correct, the knuckle joint is prestressed or raised by the amount of suspension travel of the trailer (difference in travel laden - empty). When the LSV is pressurised again, it must equalise the applied pressure. In the case of the output pressure being less than the input pressure, either the lever is too long or the spring excursion is insufficient. In the case of the output pressure being the same as the input pressure, the lever is lowered by approx. 10 % of the spring excursion towards "unladen". The resulting output pressure must be less than the input pressure. If this is not the case, either the LSV lever is too short or the suspension travel is too great.

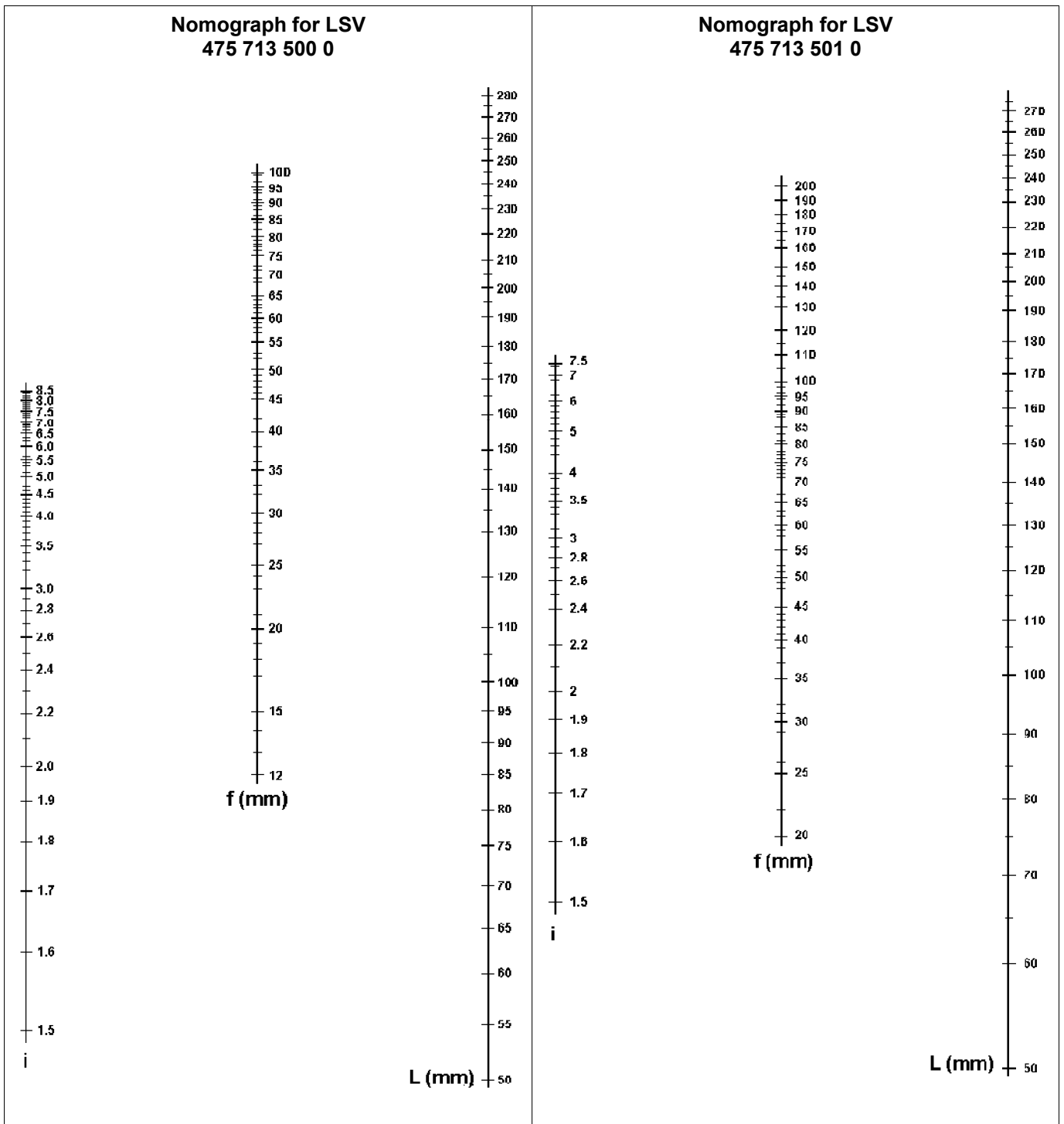

Key

i Control ratio $p_{on} -0.8 / p_{off} -0.5$

f Spring deflection

L Lever length

Technical data

Order number	475 713 500 0	475 713 501 0
Max. operating pressure	10 bar	
Max. control ratio	8:1	
Nominal diameter	Ø 10 mm	
Max. permissible adjusting torque M_2	20 Nm	
Control stroke	$\alpha = 20^\circ$	$\alpha = 33^\circ$
Thermal range of application	-40 °C to +80 °C	
Weight	1.8 kg	

Pressure diagrams

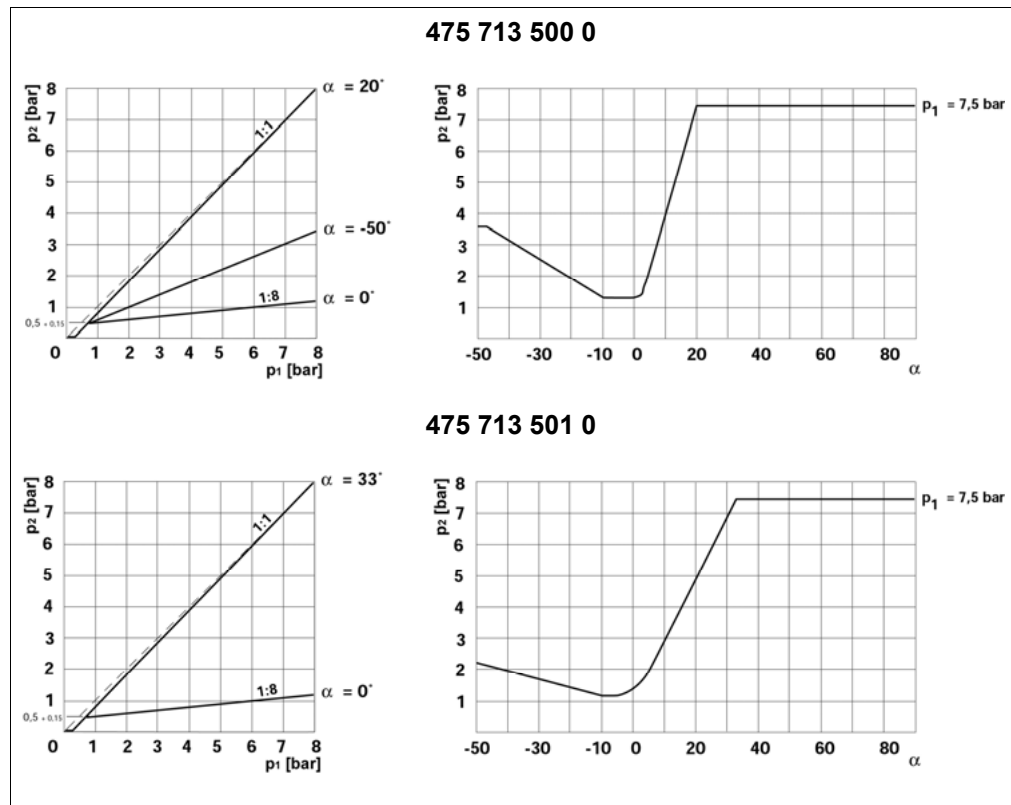

Key		
p_1	Control pressure	p_2 Output pressure
α	Lever travel [degrees]	

LSV 475 714**Application**

Static controller for air-suspension vehicles without EBS.

Purpose

Automatic control of braking pressure from air brake cylinders on air-suspension axles (axle assemblies) depending on the control pressure of the air-suspension bellows (air-bags).

Maintenance

- To test the LSVs, fasten a test hose to connection 43.
 - ➔ Screwing on presses the piston (n) into the housing, thereby interrupting connections 41 and 42 to the pistons (m and k). At the same time, a compressed air connection from connection 43 to the pistons (m and k) is created. In this state, the LSV generates a control position according to the compressed air in the test hose.

Installation recommendation

- Fasten the LSV onto the frame of the vehicle so that vent 3 faces downward.
- Make connections 41 and 42 with the air-suspension bellows (air-bags) on the right and left vehicle sides.

Installation dimensions

475 714 500 0

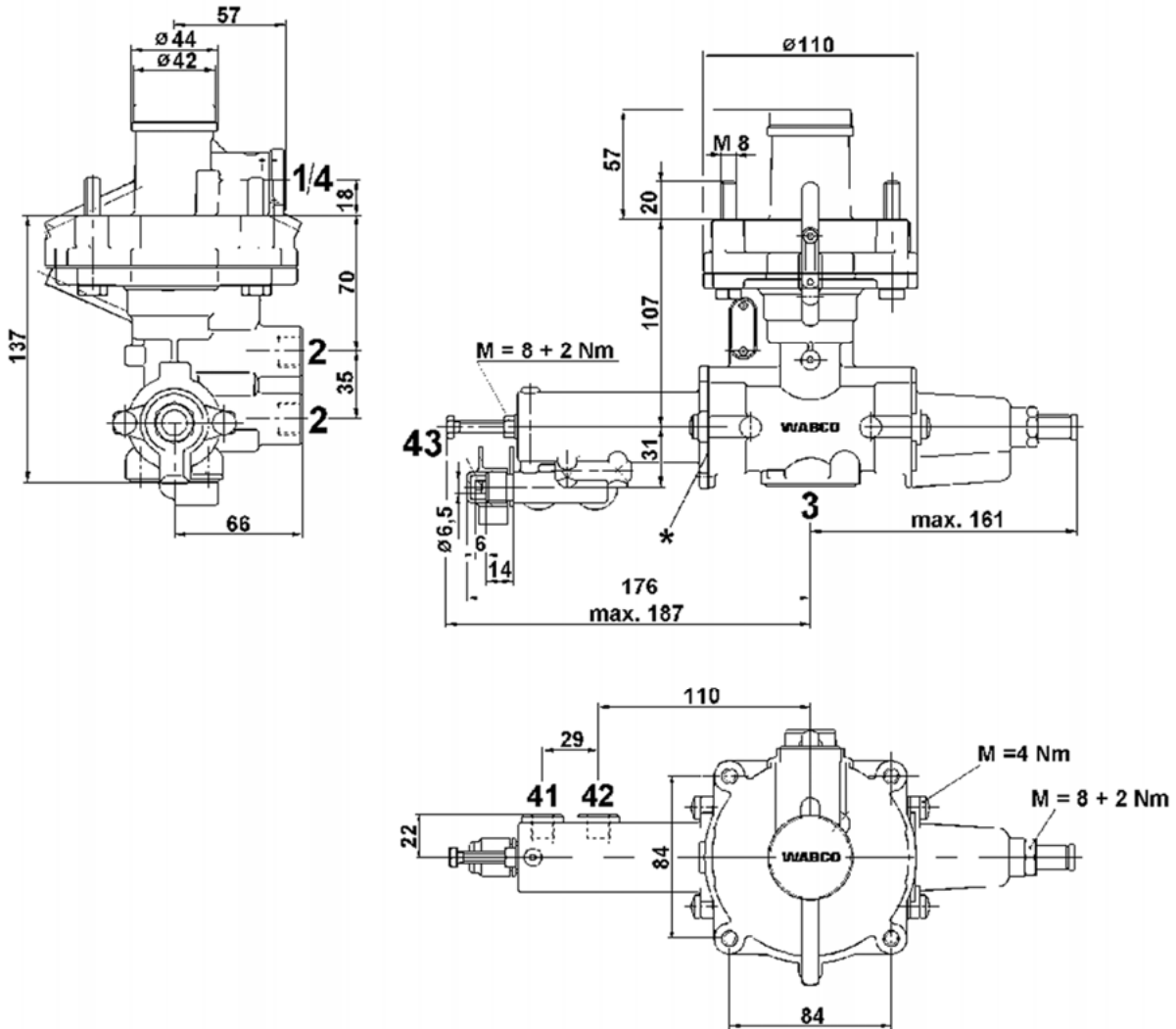

Key

* When releasing the air from the device, air can escape at the sealing surfaces.

Setting instructions



Load sensing valve program (LSV)

The required lever length can be determined with our calculation program instead of with Nomographs as well.

Open the WABCO website www.wabco-auto.com.

Then click on the links *Diagnostics => WABCO System Diagnostics => Download => Load Sensing Valve Program (LSV)*.

Description of the nomographs I and II for setting the LSVs 475 714 500 0:

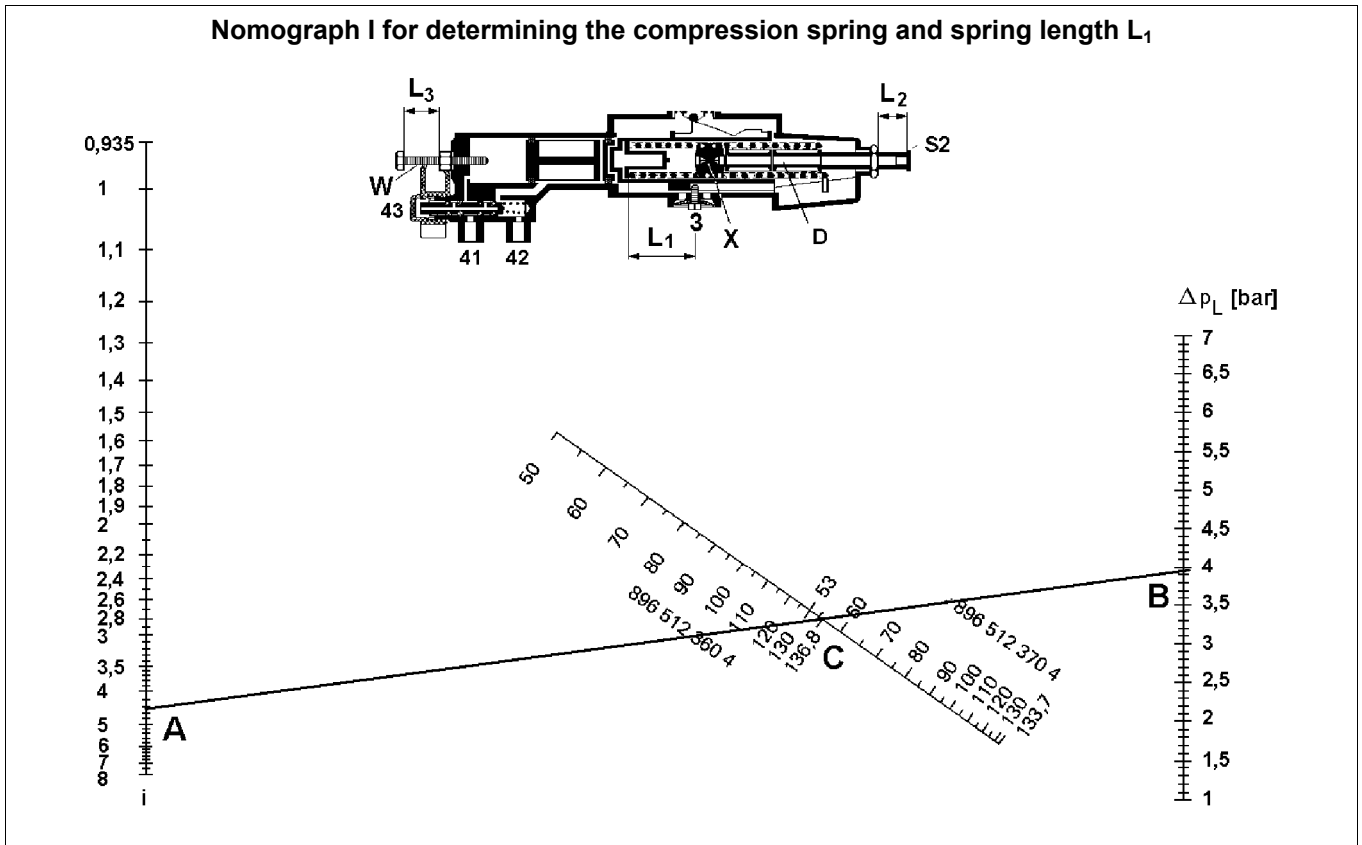

Key					
i	$p_{on} - 0.8 / p_{off} - 0.5$	S2	Bolt	896 512 360 4	Pressure spring (wire \varnothing 4 mm)
Δp_L	Air suspension bellows - pressure difference; Unladen-Laden	D	Separator	896 512 370 4	Pressure spring (wire \varnothing 3.2 mm)

Nomograph II for determining the bolt set length L_2 and the spacers N as well as L_3

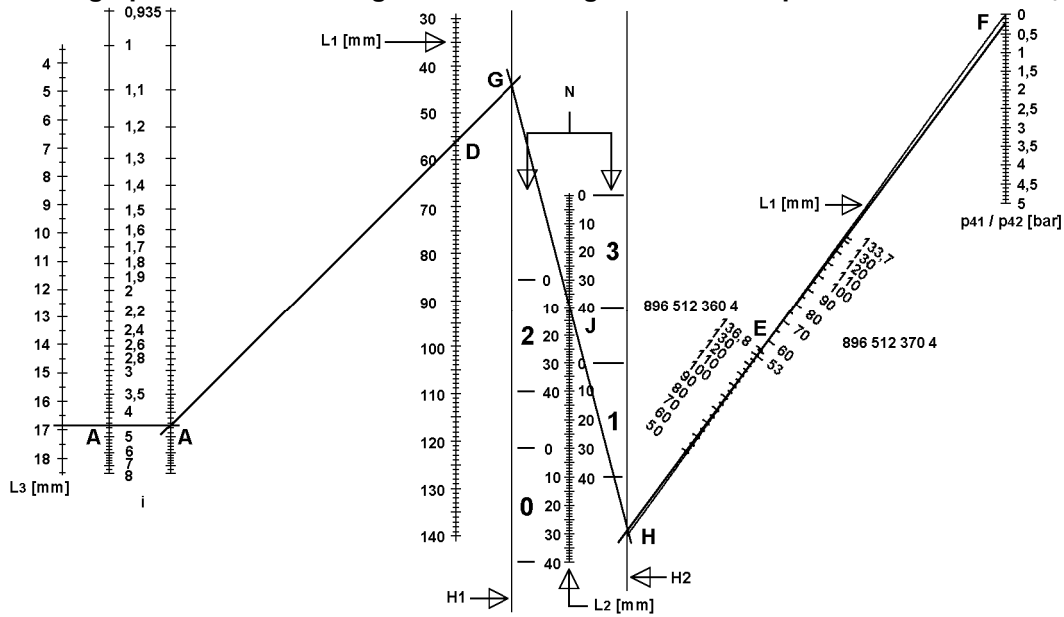

Key

L_1 Spring length	N Number of spacers	H1 Subsidiary line 1	896 512 370 4 Pressure spring
L_2 Bolt length	i Control ratio ($p_{on} - 0.8$) / ($p_{off} - 0.5$)	H2 Subsidiary line 2	896 512 360 4 Pressure spring
L_3 Unladen stop bolt (W)	p_{41}/p_{42} Air-suspension bellows pressure "Unladen"		

Determining the compression springs and set length L_1

Required adjustment values

$p_{on} (p_1) = 6.5$ bar	$p_{Bellows\ laden} = 4.1$ bar
$p_{Bellows\ unladen} = 0.2$ bar	$p_{off} = p_2\ unladen} = 1.75$ bar

- Calculating the control ratio:
 $i = (p_{on} - 0.8) / (p_{off} - 0.5) = (6.5 - 0.8) / (1.75 - 0.5) = 4.56$
- Enter the control ratio in nomographs I and II (point A).
- In addition, mark the air-suspension bellows pressure difference in nomograph I ($p_{bellows\ laden} - p_{bellows\ unladen}$), here 3.9 bar (point B).
- Connect points A-B to obtain point C at the cross-point with the identified suspension.
 → You can now read the spring length L_1 (free hanging) and the springs to be used here.
- In nomograph II, enter the spring length L_1 (point D) and the used spring with spring length L_1 (point E).
- After you have entered the air-suspension bellows pressure for the unladen vehicle (point F), connect points A-D and E-F together and extend them past D and E up to help-lines 1 and 2.
 → Connect the resulting points G and H with one another.
 At the crossing point with the help lines, you have point J, at which you can read the required number of spacers and the length of bolt L_2 .
 The values that are determined using the nomograph are guidelines and may have to be corrected.

Setting the LSVs

Before each adjustment to the bolts and pressure p_4 , connection 1 must be de-pressurised, otherwise the integrated LSV statics will not be able to be set to the required values.

Because of the production tolerances and the hysteresis, after adjusting the pressures (p_1 and $p_{41/42}$), it is always a good idea to readjust starting from 0 bar, if nothing else is specified.

- After you have installed the right springs with clamp X (set dimension L_1) and the number of spacers N in the LSV, thread in bolt 2 (L_2) until you can feel a noticeable resistance.

Setting the unladen stop bolt

After charging p_1 with the calculated pressure (in this case, 6.5 bar), the LSV must apply the unladen brake pressure (in this case, 1.75 ± 0.1 bar) at connection 2.

- If the unladen brake pressure is too high, unscrew the unladen stop bolt W (L_3); if the unladen brake pressure is too low, screw the unladen stop bolt in.



Unscrew the unladen stop bolt W to a maximum of 23 mm.

Setting the unladen brake pressure

After charging connections 41 and 42 with the unladen bellows pressure +0.2 bar (in this case, 0.4 bar) and connection 1 with the calculated pressure, the LSV must apply a pressure that is 0.2 bar higher than the unladen brake pressure with a tolerance of ± 0.1 bar (in this case 1.95 ± 0.1 bar).

- If the pressure is too low, unscrew bolt 2; if the pressure is too high, screw in bolt 2.
- Counter-lock bolt 2.

Setting the brake pressure for the laden vehicle

After charging connections 41 and 42 with the bellows pressure for the laden vehicle -0.1 bar (in this case, 4.0 bar), the LSV must apply the input pressure -0.3 bar with a tolerance of ± 0.2 bar (in this case 6.2 ± 0.2 bar).

Output pressure too low

- Determine Δp (pressure difference between nominal value and actual value).
- Lower the input pressure to 0 bar.
- Lower the bellows pressure to 0 bar and increase the value for the unladen vehicle +0.2 bar (in this case, 0.4 bar).
- Screw out bolt 2 ($\Delta p = 0.1$ bar corresponds to 3 mm).
- Screw out the spring clamp until nominal value (in this case, 1.95 ± 0.1 bar) is achieved.
- Repeat the test "Setting the brake pressure for the laden vehicle".

Output pressure too high

- Determine Δp .
- Lower the input pressure to 0 bar.
- Lower the bellows pressure to 0 bar and increase to the value for the unladen vehicle +0.2 bar (in this case, 0.4 bar).
- Screw in bolt 2 ($\Delta p = 0.1$ bar corresponds to 3 mm).
- Screw in the spring clamp until nominal value (in this case, 1.95 ± 0.1 bar) is achieved.
- Repeat the test "Setting the brake pressure for the laden vehicle".

- Actuate all test points again after setting the LSV.
- Tighten the counter nuts on bolts W and 2 to the specified torque (8 +2 Nm).
- Enter the data on the LSV plate (order number 899 144 631 4) and fasten it on the vehicle.

Technical data

Order number	475 714 500 0	475 714 509 0
Max. operating pressure p_1	10 bar	
Max. control ratio	8:1	
Max. control pressure $p_{41, 42}$	12 bar	
Thermal range of application	-40 °C to +80 °C	
Weight	1.8 kg	

Pressure diagrams

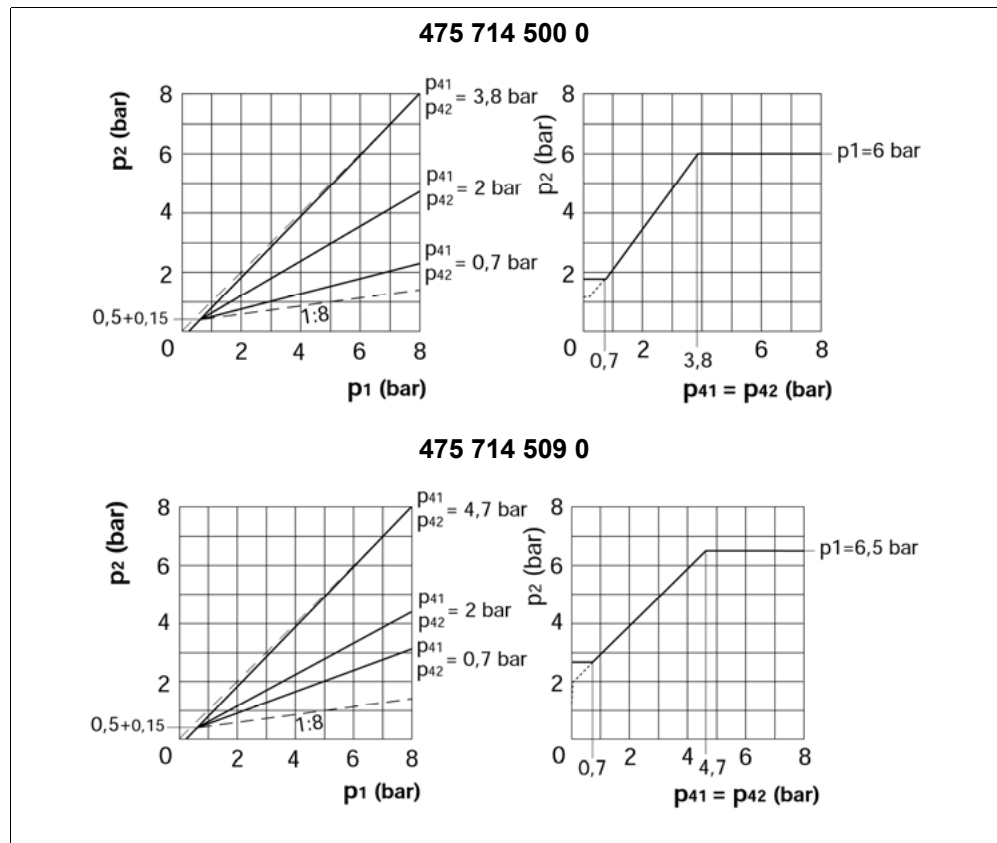

Key			
p_1	Input pressure	p_2	Output pressure
$p_{41} = p_{42}$	Control pressure		

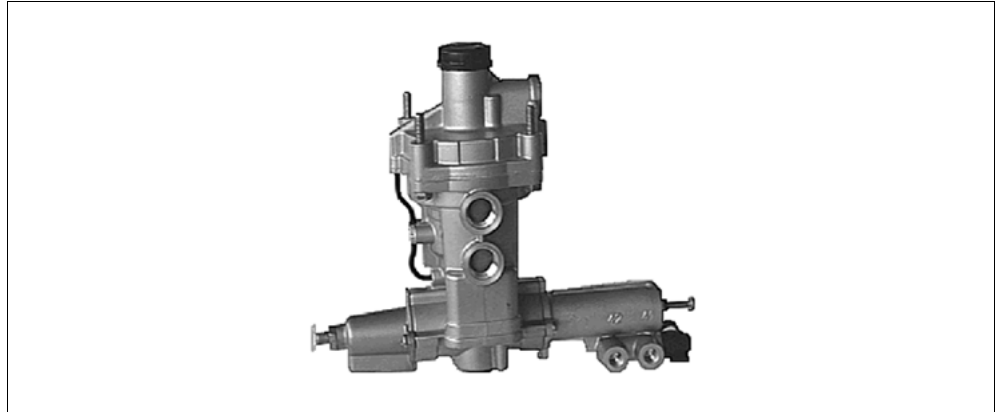
LSV trailer braking valve 475 715**Application**

Static LSV with integrated trailer brake valve for air-suspension semitrailers with multiple axles without Trailer EBS.

Purpose

Control of the two-line trailer brake systems when actuating the braking system of the truck.

Automatic control of braking force with the integrated LSV depending on the load status of the vehicle and therefore from the control pressure of the air-suspension bellows (air-bags).

Actuation of the automatic trailer braking with partial or total pressure drop in the supply line.

The LSV trailer brake valve is specially designed for air-suspension semitrailers with multiple axles.

Maintenance

- To test the LSVs, fasten a test hose to connection 43.
 - ➔ Screwing on presses the piston (q) into the housing, thereby interrupting connections 41 and 42 to the pistons (p and o). At the same time, a compressed air connection from connection 43 to the pistons is created. In this state, the LSV generates a control position according to the compressed air in the test hose.

Installation recommendation

- Fasten the LSV trailer brake valve onto the frame of the vehicle so that vent 3 faces downward.
- Make connections 41 and 42 with the air-suspension bellows (air-bags) on the right and left vehicle sides.

Installation dimensions

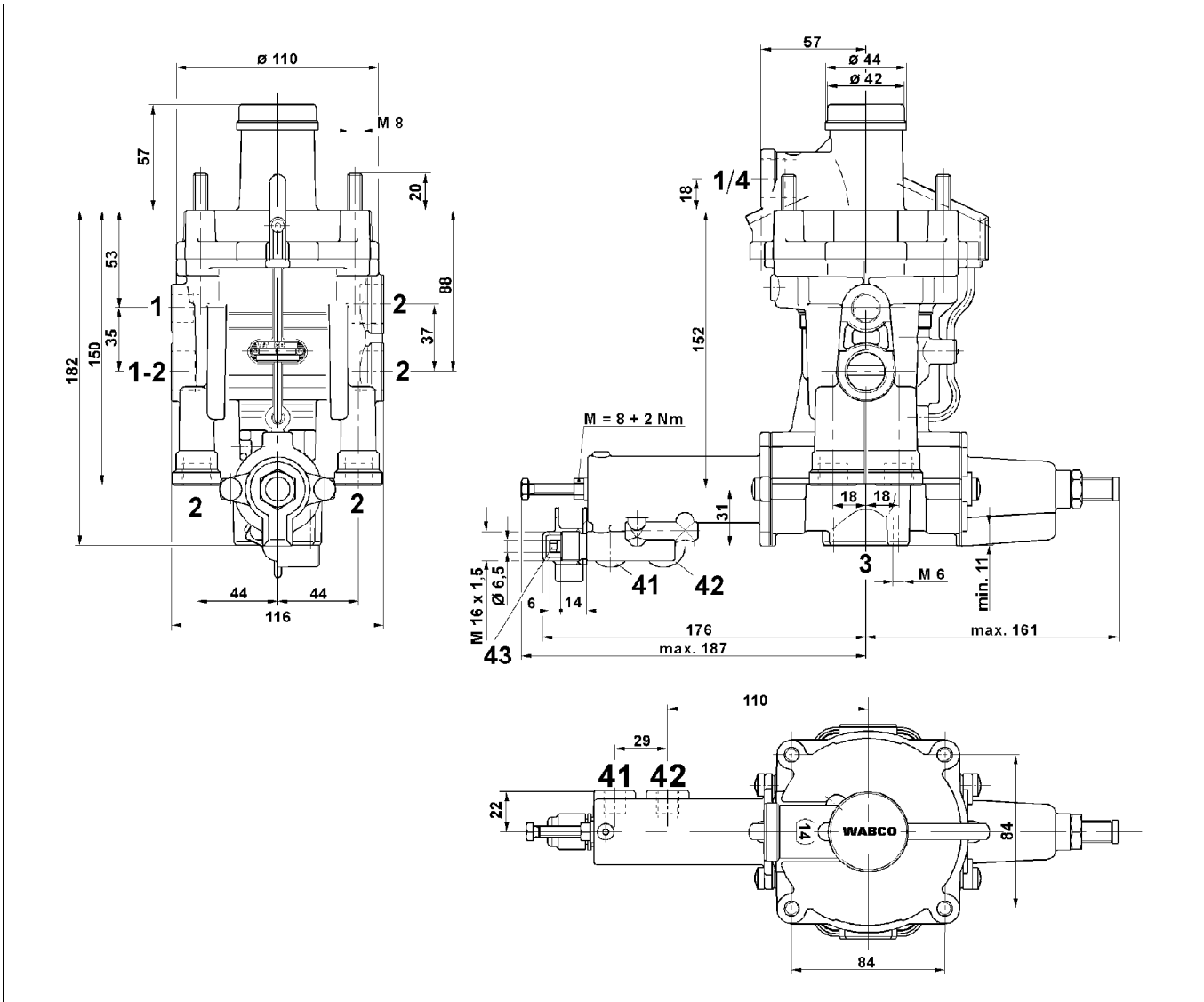

Connections		Port threads					
1-2	Energy supply / Energy delivery	1, 1-4	Energy supply	1	M 16x1.5 - 12 deep	1-2, 1/4	M 22x1.5 - 13 deep
2	Energy delivery	3	Exhaust	2	M 16x1.5 - 12 deep (bottom)	2	M 22x1.5 - 13 deep (side)
41, 42	Control port	43	Pressure test connection	41, 42	M 12x1.5 - 10 deep		

Setting instructions



Load sensing valve program (LSV)

The required lever length can be determined with our calculation program instead of with Nomographs as well.

Open the WABCO website www.wabco-auto.com.

Then click on the links *Diagnostics => WABCO System Diagnostics => Download => Load Sensing Valve Program (LSV)*.

Description of the nomographs I and II for setting the LSV trailer brake valve 475 715 5.. 0

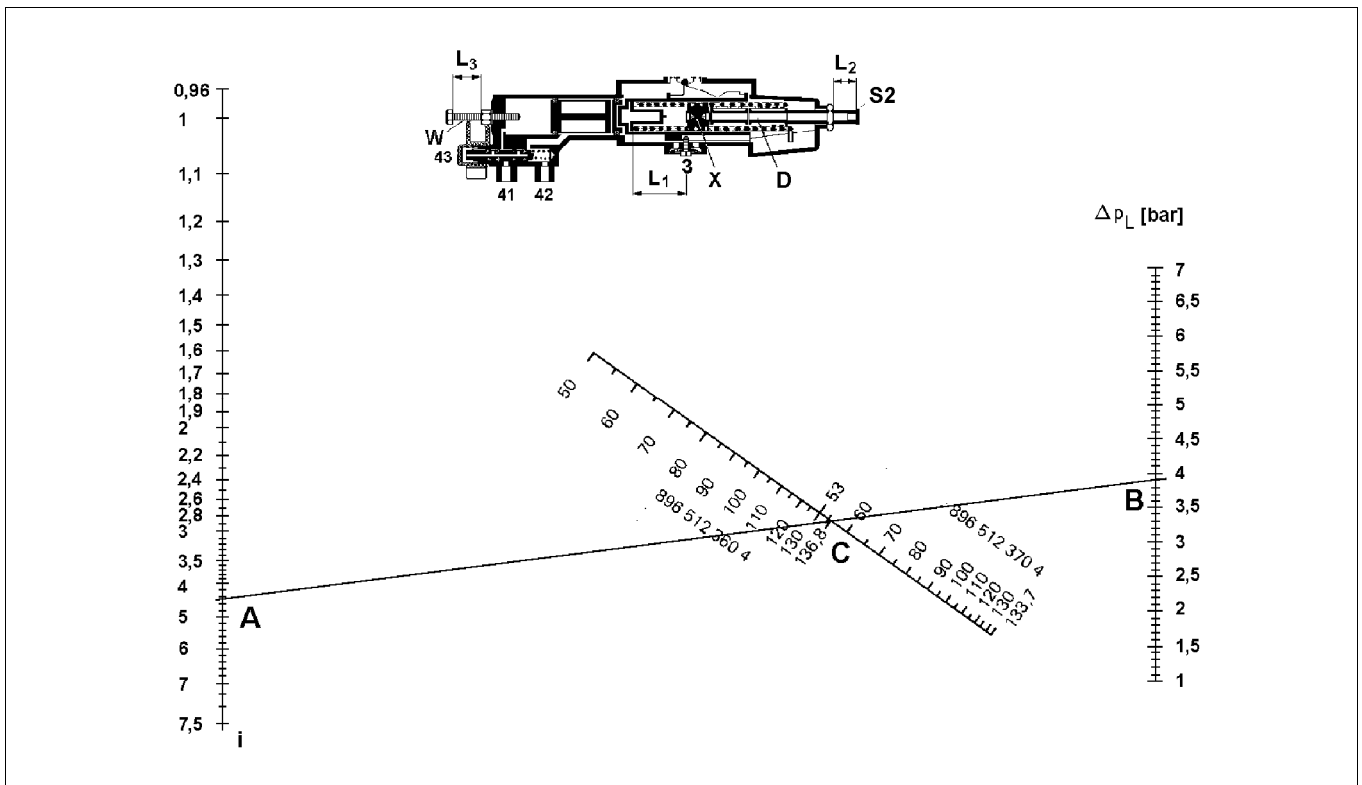

Key					
i	Control ratio ($p_{on} - 0.8$) / ($p_{off} - 0.5$)	D	Separator	896 512 360 4	Pressure spring (wire \varnothing 4 mm)
S2	Bolt	Δp_L	Air suspension bellows - pressure difference; $p_{Bellows\ laden} - p_{Bellows\ unladen}$	896 512 370 4	Pressure spring (wire \varnothing 3.2 mm)

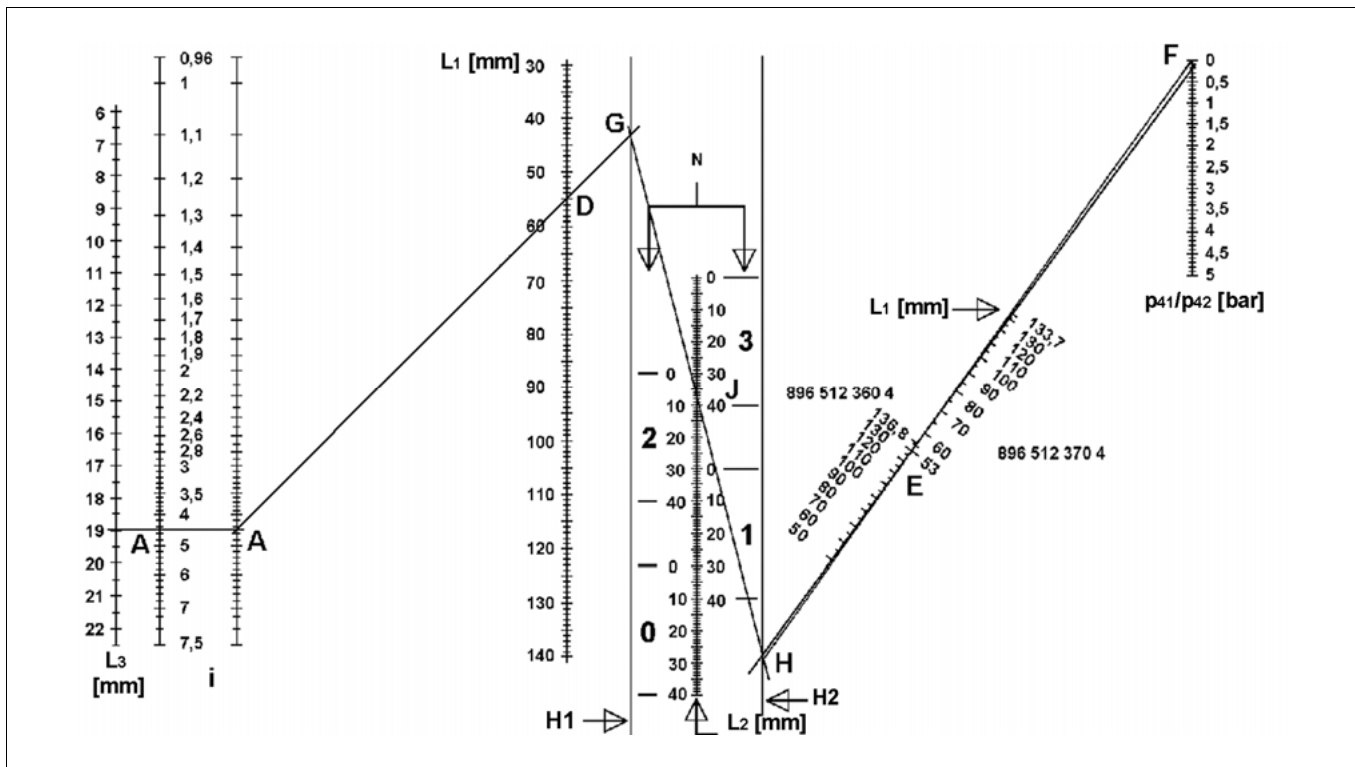

Key							
L ₁	Spring length	H1	Subsidiary line 1	N	Number of spacers	896 512 360 4	Pressure spring
L ₂	Bolt length	H2	Subsidiary line 2	i	Control ratio	896 512 370 4	Pressure spring
L ₃	Unladen stop bolt (W)	p ₄₁ /p ₄₂	Air-suspension bellows pressure "Unladen"				

Determining the compression springs and set length L₁ and the number of spacers

Required adjustment values	
p _{on} (p ₁) = 6.5 bar	p _{Bellows laden} = 4.1 bar
p _{Bellows unladen} = 0.2 bar	p _{off} = p _{2 unladen} = 1.75 bar

- Calculate the control ratio:
 $i = (p_{on} - 0.8) / (p_{off} - 0.5) = (6.5 - 0.8) / (1.75 - 0.5) = 4.65$
- Enter the control ratio in nomographs I and II (point A).
- In addition, mark the air-suspension bellows pressure difference in nomograph I (p_{bellows laden} - p_{bellows unladen}), here 3.9 bar (point B).
- Connect points A-B to obtain point C at the cross-point with the identified suspension.
 → You can now read the spring length L₁ (free hanging) and the springs to be used here.
- In nomograph II, enter the spring length L₁ (point D) and the used spring with spring length L₁ (point E).
- After you have entered the air-suspension bellows pressure for the unladen vehicle (point F), connect points A-D and E-F together and extend them past D and E up to help-lines 1 and 2.
 → Connect the resulting points G-H with one another.

At the crossing point with the help lines, you have point J, at which you can read the required number of spacers and the length of bolt L_2 .

The values that are determined using the nomograph are guidelines and may have to be corrected.

Setting the LSVs

Before each adjustment to the bolts and pressure $p_{41/p42}$, connection 4 must be depressurised, otherwise the integrated statics of the LSV trailer brake valve 475 715 5.. 0 will not be able to be set to the required values.

Because of the production tolerances and the hysteresis, after adjusting the pressures (p_1 and $p_{41/42}$), it is always a good idea to readjust starting from 0 bar, if nothing else is specified.

- After you have installed the right springs with clamp X (set dimension L_1) and the number of spacers N in the LSV, thread in bolt 2 until you can feel a noticeable resistance.

Setting the unladen stop bolt

After charging p_4 with the calculated pressure (in this case, 6.5 bar), the LSV trailer brake valve must apply the unladen brake pressure (in this case, 1.75 ± 0.1 bar) at connection 2.

- If the unladen brake pressure is too high, unscrew the unladen stop bolt W (L_3); if the unladen brake pressure is too low, screw the unladen stop bolt in



Unscrew the unladen stop bolt W to a maximum of 23 mm.

Setting the unladen brake pressure

After charging connections 41 and 42 with the unladen bellows pressure +0.2 bar (in this case, 0.4 bar) and connection 4 with the calculated pressure, the LSV trailer brake valve must apply a pressure that is 0.2 bar higher than the unladen brake pressure with a tolerance of ± 0.1 bar (in this case 1.95 ± 0.1 bar).

- If the pressure is too low, unscrew bolt 2; if the pressure is too high, screw in bolt 2.
- Counter-lock bolt 2.

Setting the brake pressure for the laden vehicle

After charging connections 41 and 42 with the bellows pressure for the laden vehicle -0.1 bar (in this case, 4.0 bar), the LSV must apply the input pressure -0.3 bar with a tolerance of ± 0.2 bar (in this case 6.2 ± 0.2 bar).

Output pressure too low

- Determine Δp (pressure difference between nominal value and actual value).
- Lower the input pressure to 0 bar.
- Lower the bellows pressure to 0 bar and increase to the value for the unladen vehicle +0.2 bar (in this case, 0.4 bar).
- Screw out bolt 2 ($\Delta p = 0.1$ bar = 3 mm).
- Screw out the spring clamp until nominal value (in this case, 1.95 ± 0.1 bar) is achieved.
- Repeat the test "Setting the brake pressure for the laden vehicle".

Output pressure too high

- Determine Δp .
- Lower the input pressure to 0 bar.

- Lower the bellows pressure to 0 bar and increase to the value for the unladen vehicle +0.2 bar (in this case, 0.4 bar).
- Screw in bolt 2 ($\Delta p = 0.1 \text{ bar} = 3 \text{ mm}$).
- Screw in the spring clamp until nominal value (in this case, $1.95 \pm 0.1 \text{ bar}$) is achieved.
- Repeat the test "Setting the brake pressure for the laden vehicle".
- Actuate all test points again after setting the LSV.
- Tighten the counter nuts on bolts W and 2 to the specified torque ($8 + 2 \text{ Nm}$).
- Enter the data on the LSV plate (order number 899 144 631 4) and fasten it on the vehicle.

Technical data

Order number	475 715 500 0	475 715 507 0	475 715 513 0	475 715 514 0
Max. operating pressure $p_{1/4}$	10 bar			
Max. control ratio	8:1			
Max. control pressure $p_{41,42}$	12 bar			
Thermal range of application	-40 °C to +80 °C			
Weight	1.8 kg			

Pressure diagrams

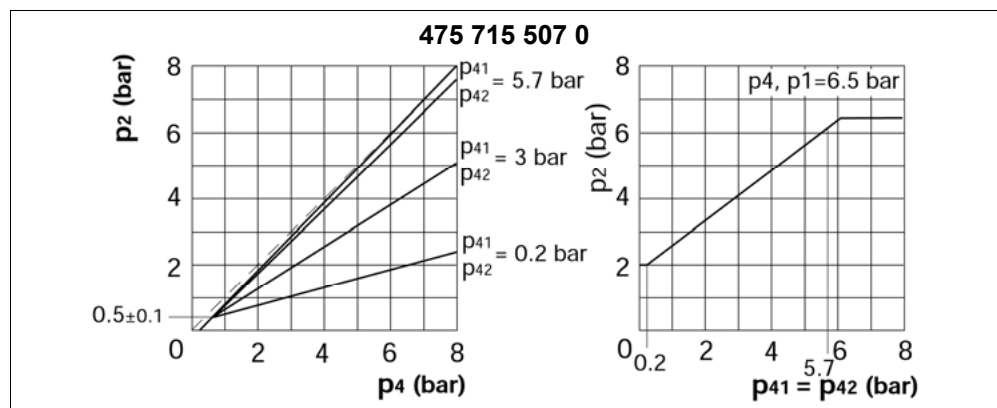
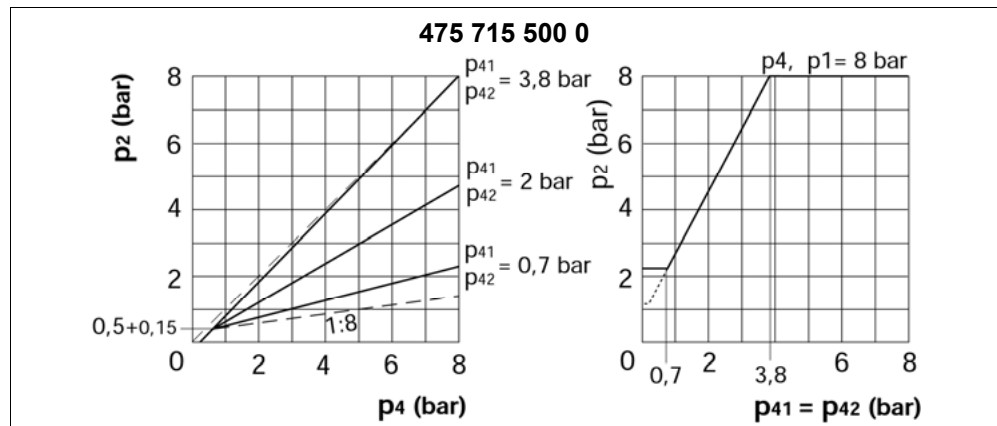

Key					
p_2	Output pressure	p_4	Input pressure	$p_{41} = p_{42}$	Control pressure

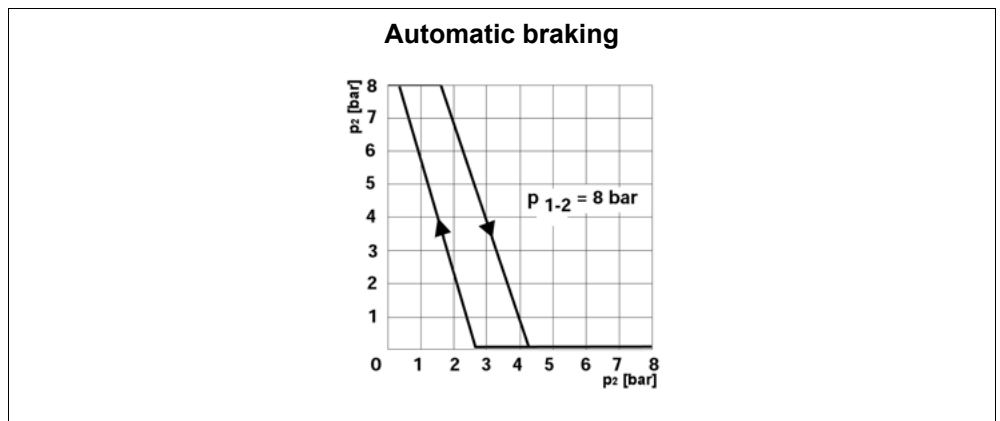
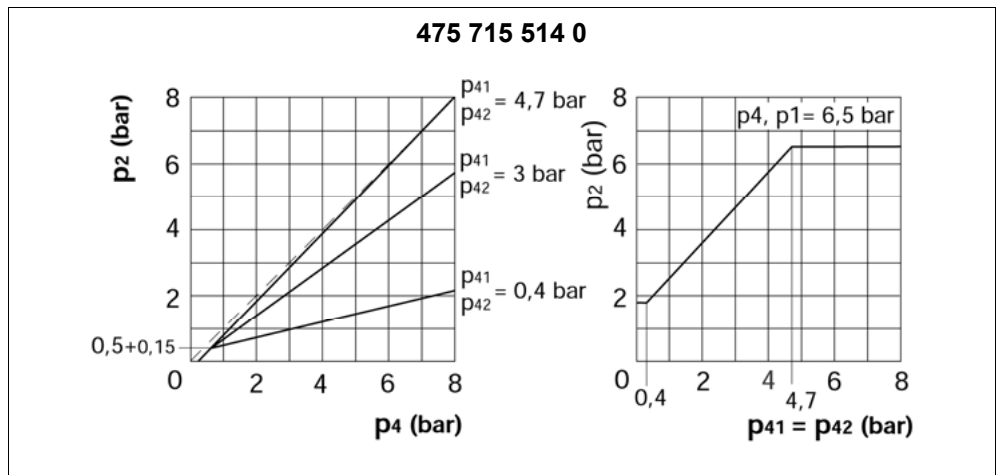
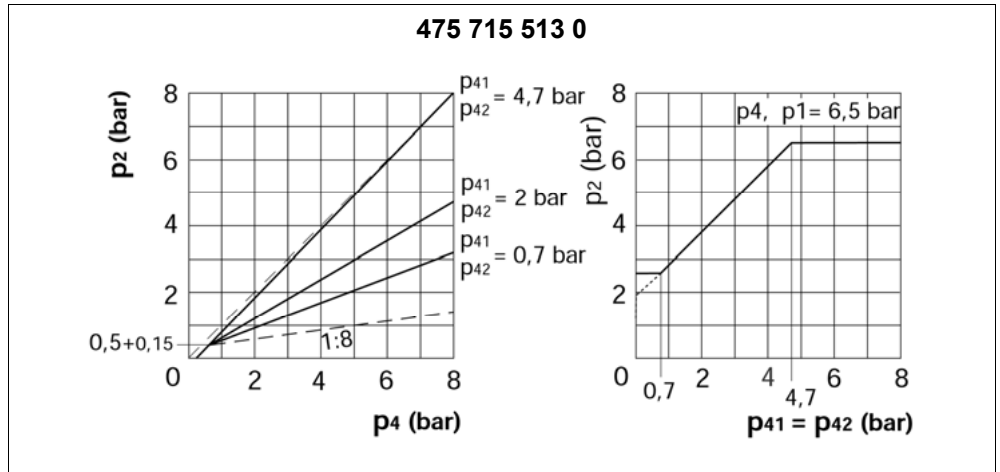

Key			
p_2	Output pressure	p_4	Input pressure
		$p_{41} = p_{42}$	Control pressure

Plates "Set values LSV " 899 144 63. 4

The vehicle is to be equipped according to the required LSV specifications conforming with EC Guideline 71/320 EWG Appendix II Annex to II/1.1.4.2 Paragraph 7 and the ECE provision No. 13 Appendix 10 Paragraph 7. The respective signs can be obtained from WABCO (see following figures). These signs correspond with the draft for standards DIN 74267 of September 1982 Form C and D. They are provided in three languages and offer the capability for table entries for axle loads and the output pressures of the LSV.

! The pressures to be entered in the LSV sign must be measured immediately before and after the LSV, so that it is not influenced by the characteristics of other devices of the brake system.

In the configuration of the brake systems, test connections are to be designed according to standard ISO standard 3583/1974 before and after the LSV controller. On control connection 41 or 42 from pneumatically hydraulically actuated LSVs, a special test connection is required. It blocks the control pressure from the air-suspension bellows or the overflow cylinders when the test hose is connected. When the trailer is empty, any charge status can be simulated with the help of test apparatus 435 008 000 0.

With mechanically hinged LSVs, the required charge status for checking the LSVs is achieved with a manual adjustment.

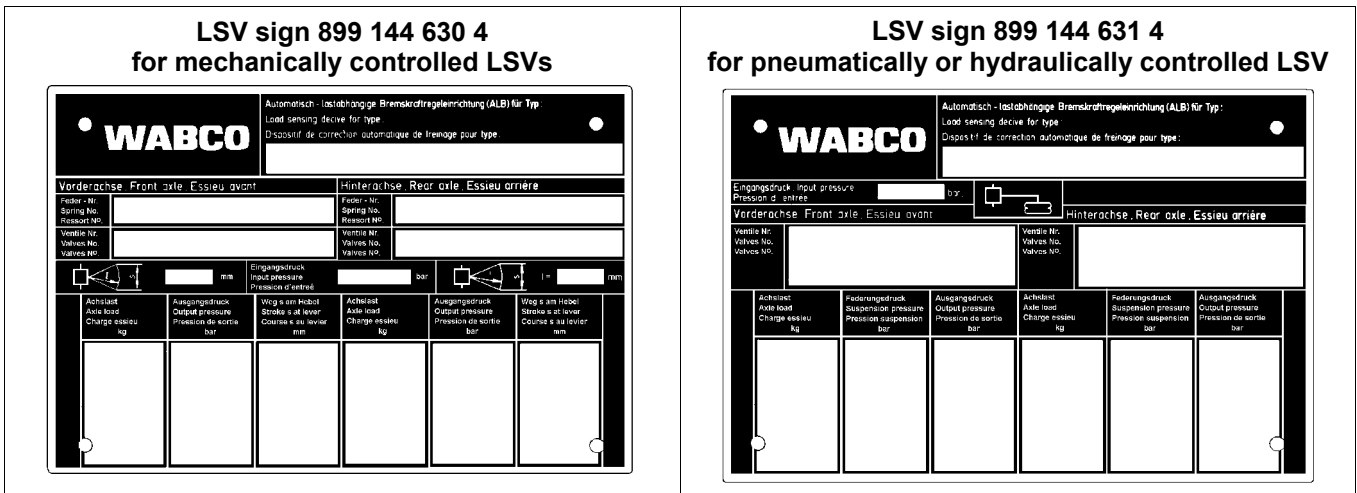

With two LSVs with different input pressure, both pressures are to be noted on the LSV sign, e.g. 6.5/5.7.

Nomographs**Nomographs**

Open the WABCO website www.wabco-auto.com.
Click on *Product Catalogue INFORM => Product number*.
Enter the desired LSV number into the search field.
Click the *Start* button.
Click the link *Publications*

LSV	Nomographs
475 710 040 0	475 710 902 3
475 712 000 0	475 710 902 3
475 713 50. 0	475 713 902 3
475 714 5.. 0	475 714 902 3
475 715 ... 0	475 715 902 3

5.26 Load-dependent control valve 475 800



Application

Vehicles with leaf-spring and trailing steering axle.

Purpose

Control of the steering stabilisation on a trailing steering axle depending on the spring deflection and thus on the load status of the vehicle.

Maintenance

Special maintenance that extends beyond the legally specified inspections is not required.

Installation recommendation

- Install the load-dependent control valve vertically so that the vent 3 points downward.
- Fasten the load-dependent control valve with two M8 bolts on the respective flange.

Installation dimensions

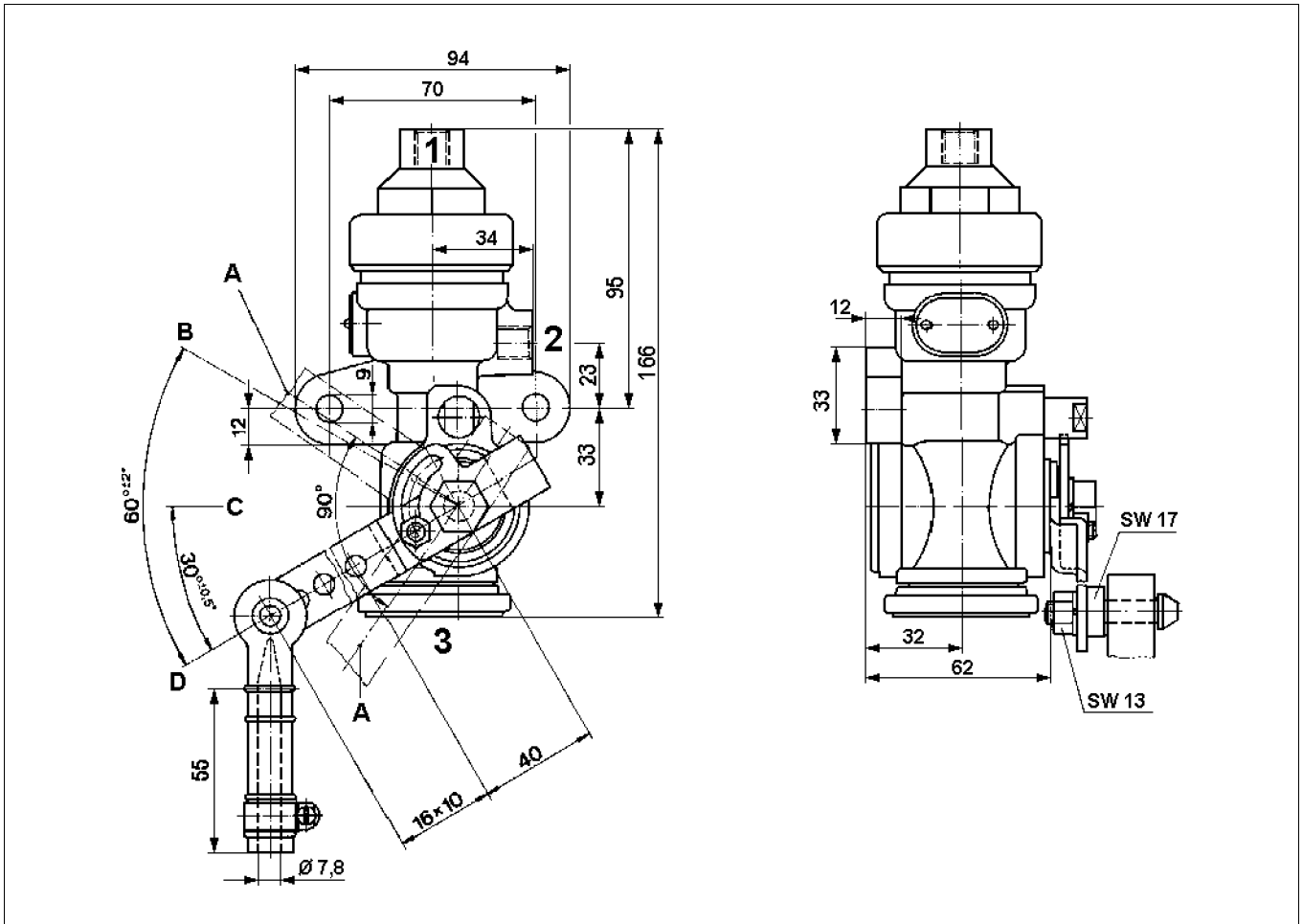

Connections		Port threads		Key	
1	Energy supply	3	Exhaust	M 12x1.5 - 12 deep	
2	Energy delivery				
				A	Over travel
				B	Fully laden position
				C	Central position
				D	Unladen position

Diagram

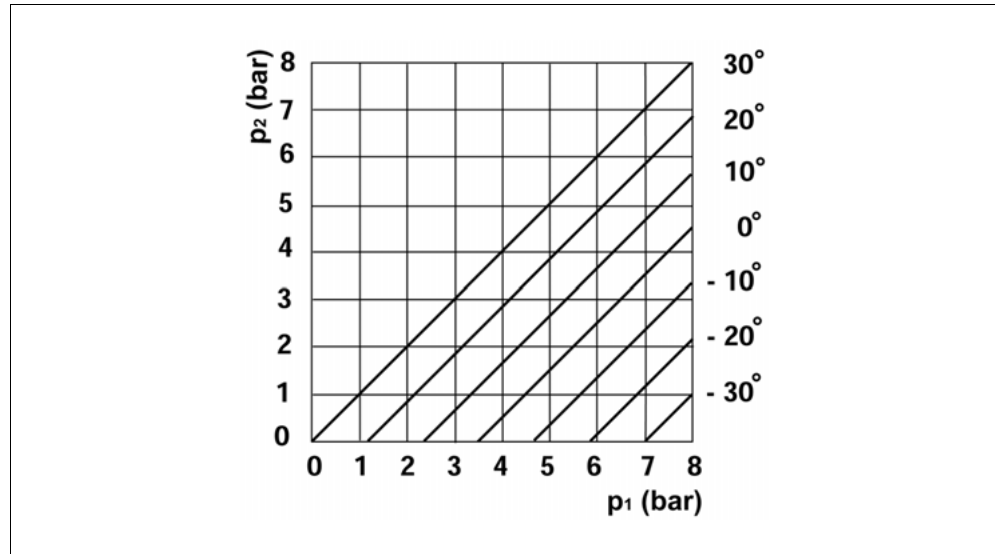

Key			
p_1	Input pressure	p_2	Output pressure
		-30° to 30°	Lever travel

Determining lever length L

For determining the lever length L, the following values must be known:

Spring deflection $f = \dots$ mm	Output pressure "unladen" $p_{2 \text{ unladen}} = \dots$ bar
Supply pressure $p_1 = \dots$ bar	Output pressure "laden" $= p_{2 \text{ laden}} = \dots$ bar

- For determining scale point A (output pressure p_2) subtract $p_{2 \text{ unladen}}$ from $p_{2 \text{ laden}}$.
 - Then subtract the determined pressure difference Δp_2 from the supply pressure p_1 .
 - The resulting value p_2 is the starting point A for a line that is made to point B (scale for spring deflection f).
- The extension of these lines cross the scale of lever length L, at which the lever length at point C can then be read.

Example

$f = 40$ mm

$p_1 = 7.0$ bar

$p_{2 \text{ unladen}} = 1.8$ bar

$p_{2 \text{ laden}} = 5.5$ bar

$\Delta p_2 = p_{2 \text{ laden}} - p_{2 \text{ unladen}} = 5.5 - 1.8 = 3.7$ bar

$p_2 = p_1 - \Delta p_2 = 7.0 - 3.7 = 3.3$ bar

In the following nomograph, a line is made from scale point A = 3.3 bar to scale point B = 40 mm. Extending this line crosses the scale for lever length L in point C at 75 mm.

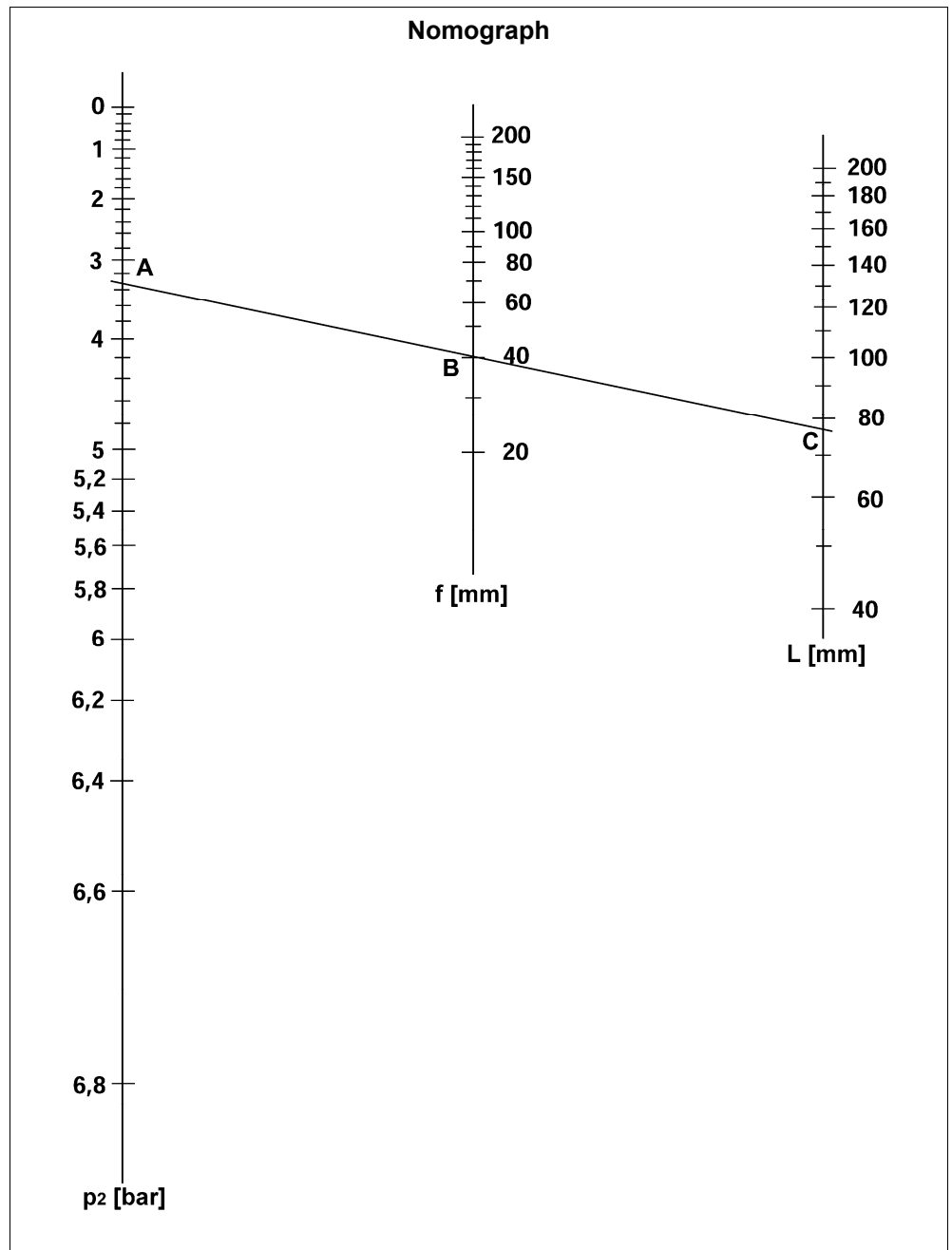

Key		
f	Spring deflection	L Lever length
p₂	Output pressure for p ₁ = 7 bar	

Technical data

Order number	475 800 301 0
Max. operating pressure	8 bar
Control range	0 to 7.2 bar
Permissible medium	Air
Thermal range of application	-40 °C to +80 °C
Weight	1.1 kg

5.27 Tristop® Cylinder 925 ...

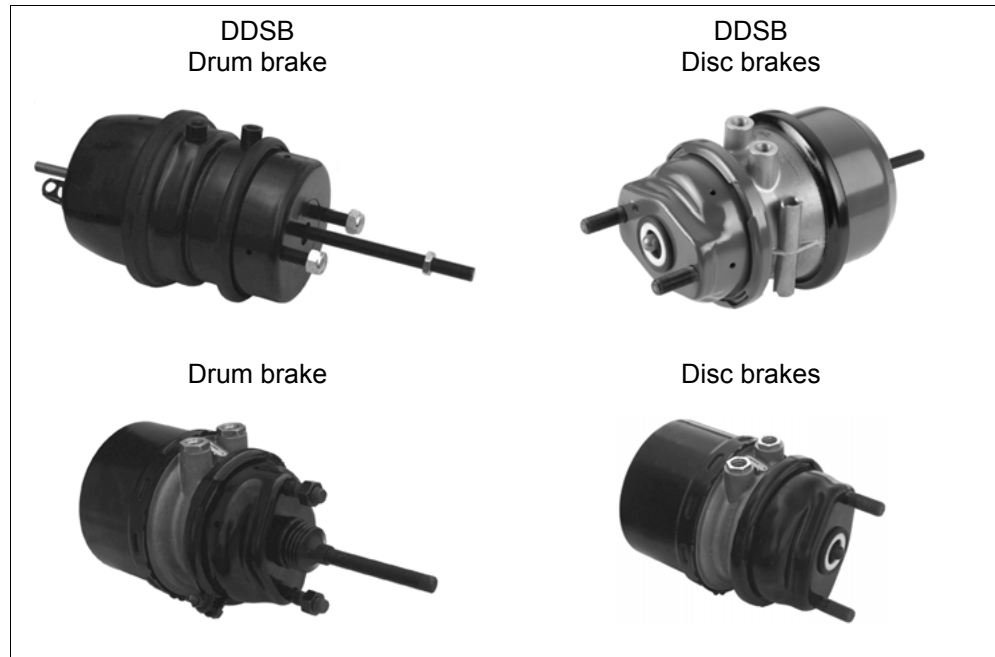
**Application**

Utilisation on at least one vehicle axle.

Purpose

Combined spring brake - diaphragm brake chambers (Tristop® Cylinders) are used to generate the brake force for the wheel brakes. They consist of the diaphragm portion for the service braking system and the spring-loaded portion for the auxiliary and parking braking systems.

Installation instructions for Tristop® cylinders

The approval of the axle manufacturer is necessary for installing Tristop® cylinders. WABCO is available for any enquiries regarding testing methods.

Mounting bracket

To ensure enduring bolt tension, the following points must be considered:

- A flat mounting surface (deviation of maximum 0.4 mm) over a breadth of at least 146 mm and a height of at least 40 mm above and below the fastening bolts is necessary.
- The mounting surface of the bracket is only to be primed and not painted.
- Direct contact is required between bracket/cylinder and cylinder/nut.
- Do not use reinforcement strips, intermediate plates, washers, spring lock-washers and other locking elements.

Installation

- Install the Tristop® cylinder with up to a 30° slant between horizontal upward facing and vertical downward facing piston rod.

The open drain/breather hole must point downwards (maximum permissible deviation $\pm 30^\circ$).



Install the Tristop® cylinder with gaiter seal with the piston rod at a maximum of a 60° downward angle.

- Seal additional drain holes (exception TSL cylinder!).
 - Seal the opening for the release screw.
- The bleed line between the service brake part and the spring brake part must run in the area of the upper half of the Tristop® cylinder.
- The maximum permitted displacement of the piston rod is 3° on all sides.

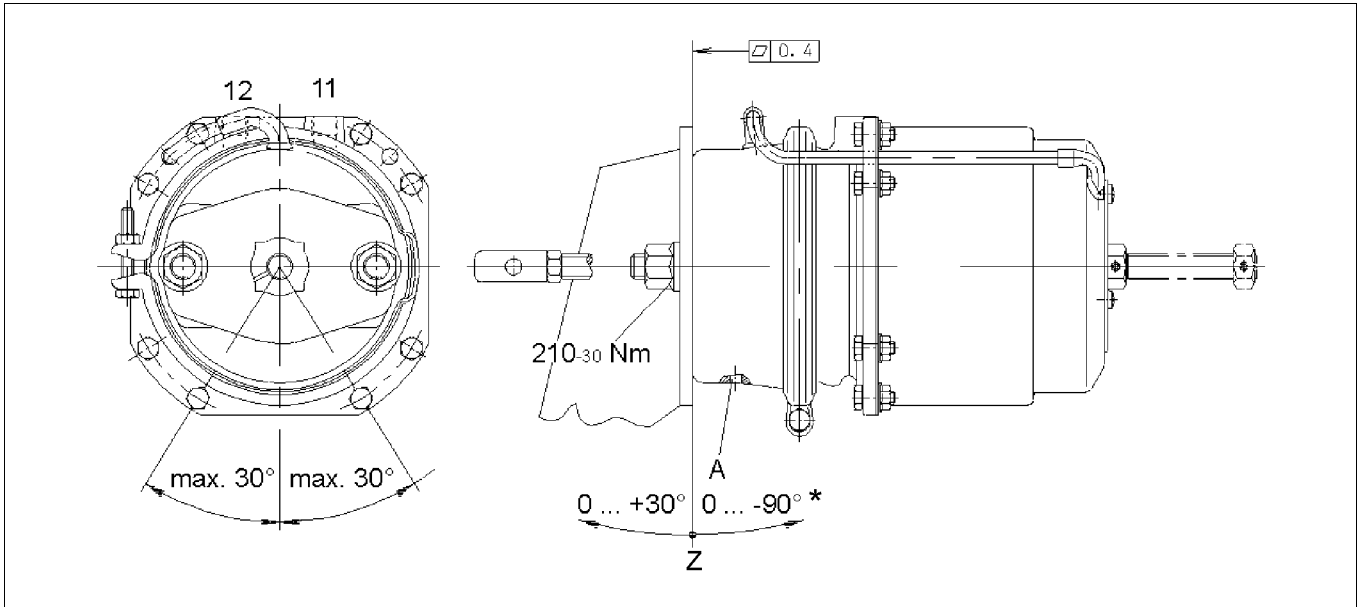

Key			
B	Drain hole	Z	Permissible fitting position
		*	0 to -60° using Tristop® cylinder with gaiter

Fastening

Fastening the Tristop® cylinder requires the use of nuts M 16x1.5 – strength class 8 – DIN EN 28673, ISO 8673 (in accessories pack, WABCO No. 423 903 532 2).

- Thread on both nuts by hand until the Tristop® cylinder makes full contact.
- Tighten the nuts to approximately 120 Nm (e.g. with an impact wrench).
- Tighten the nuts to 210 Nm (tolerance -30 Nm) using a torque wrench. Increase the tightening torque appropriately when using self-locking nuts.
- Check the tightening torque of 210 Nm in accordance with the maintenance intervals of the axle manufacturer.

! Steering axle specifics

When installing Tristop® cylinders on steering axles, ask the axle manufacturer about the respective installation situation.

Spare

When replacing a brake chamber, check the bracket for any damage and replace according to the axle manufacturer's recommendations if necessary.

Installing a larger cylinder than type 30/30

Types 36/36 and 36/30 are not to be mounted using horizontally positioned fastening bolts. In this case, a vertical position with a deviation of ±30° is permitted.

General

WABCO Tristop® cylinders are delivered with the springs under tension. Release the springs before commissioning the vehicle.

With the TSL types, fasten the release screw in the hole provided on the side. Close the hole, on the cover with the cap attached to the device.

Installation instructions for Tristop® cylinders (disc brake)**Installation**

- Install the Tristop® cylinder horizontally.
Permissible deviation: 10° with push rod showing upward and 30° showing downwards.
The open drain/breather hole must point downwards (maximum permissible deviation $\pm 30^\circ$).
- Remove the lower plastic plug.
The connecting line between the service brake part and the spring brake part must run in the area of the upper half of the Tristop® cylinder.

Fastening

Fastening the Tristop® cylinder requires using nuts M 16x1.5 – Strength class 8 – DIN 934 (WABCO No. 810 304 031 4).

- Thread on both nuts by hand until the Tristop® cylinder makes full contact.
Make sure that the piston rod goes into the calotte of the brake lever.
Make sure that the flange surfaces and sealing surfaces of the cylinder and the disc brake are clean and undamaged.
Make sure that the gaiters are not damaged and are seated properly together with the back-up ring.
- Tighten both nuts to approximately 120 Nm (e.g. with an impact wrench).
- Tighten both nuts to 210 Nm (tolerance -30 Nm) using a torque wrench.
- Move the release bolt to drive position after fastening (secure with 25^{+20} Nm).

Install dimensions - Double diaphragm spring brake actuator for S-cam drum brake**Outline drawing with install dimensions**

Open the WABCO website www.wabco-auto.com.

Click on *Product Catalogue INFORM* => *Product number*.

Enter the order number of the desired double diaphragm spring brake actuator into the search field.

Click the *Start* button.

Technical Data - Double diaphragm spring brake actuator for S-cam drum brake

Order number	Type	Max. stroke [mm] Brake chamber and spring chamber cyl- inder	Displacement of push rod in any di- rection	Volume-stroke of the brake chamber at 2/3 stroke [litres]	Volume stroke of the spring brake cylinder [litres]	Max. operating pres- sure [bar]	Thermal range of application	Install dimensions D [mm]	Weight [kg]
925 375 100 0	20/30	75	6°	0.9	2.12	8.5	-40 °C to +80 °C	149	9.2
925 376 100 0	24/30	75	6°	1.9	2.12			162	9.7
925 376 101 0	24/30	75	6°	1.09	2.12			162	9.7
925 376 103 0	24/30	75	6°	1.09	2.12			162	9.9
925 376 106 0	24/30	75	6°	1.16	2.12			162	10.3
925 376 107 0	24/30	75	6°	1.09	2.12			162	9.9
925 376 110 0	24/30	75	6°	1.09	2.12			162	9.9
925 376 200 0	24/30	64	6°	0.9	1.92			161	9.3
925 377 100 0	30/30	75	6°	1.32	2.12			182	10
925 377 101 0	30/30	75	6°	1.32	2.12			182	10
925 377 102 0	30/30	75	6°	1.32	2.12			182	10
925 377 103 0	30/30	75	6°	1.32	2.12			182	10.2
925 377 105 0	30/30	75	6°	1.32	2.12			182	10.2

423 903 535 2 Yoke end without fastening nut / 423 903 532 2 Yoke end with nut

Pressure diagrams - Double diaphragm spring brake actuator for S-cam drum brake

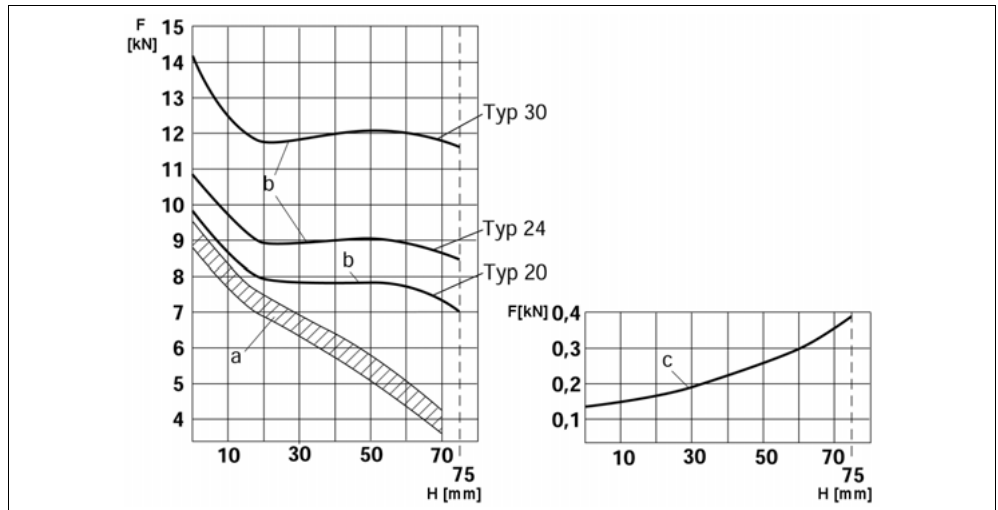

Key	
a	Output force of the spring chamber, release pressure $p_e = 4.6 \pm 0.3$ bar
b	Output force of the service brake part at $p_e = 6.5$ bar
c	Return-spring force of the service brake part
F	Force
H	Stroke

Technical data – Tristop® Cylinder (cam)

Order number	Type	Max. stroke [mm] Brake chamber and spring chamber cylinder	Release torque [Nm] release mechanism Tightening torque [Nm]		Displacement of push rod in any direction	Volume-stroke of the brake chamber at 2/3 stroke [litres]	Volume stroke of the spring brake cylinder [litres]	Max. operating pressure	Thermal range of application	Weight [kg]
925 494 041 0	16/24	65	15 ⁺²⁰	25 ⁺²⁰	3°	1.13	1.8	8.5 bar	-40 °C bis +80 °C	11.5
925 490 105 0	20/24	65	15 ⁺²⁰	70	3°	0.8	1.4			9.8
925 491 114 0	24/24	65	15 ⁺²⁰	70	3°	0.8	1.4			9.8
925 491 111 0	24/30	65	15 ⁺²⁰	70	3°	0.8	1.4			9.9
925 492 204 0 *	30/24	65	15 ⁺²⁰	70	3°	1.13	1.4			9.2
925 492 208 0	30/30	65	15 ⁺²⁰	70	3°	1.13	1.8			11.5
925 492 300 0**	30/30	65	15 ⁺²⁰	70	3°	1.13	1.8			9.9

Key

* Install position +90° / -30°

** Install position +50° / -10°

Pressure diagrams – Tristop® Cylinder (cam lobe)

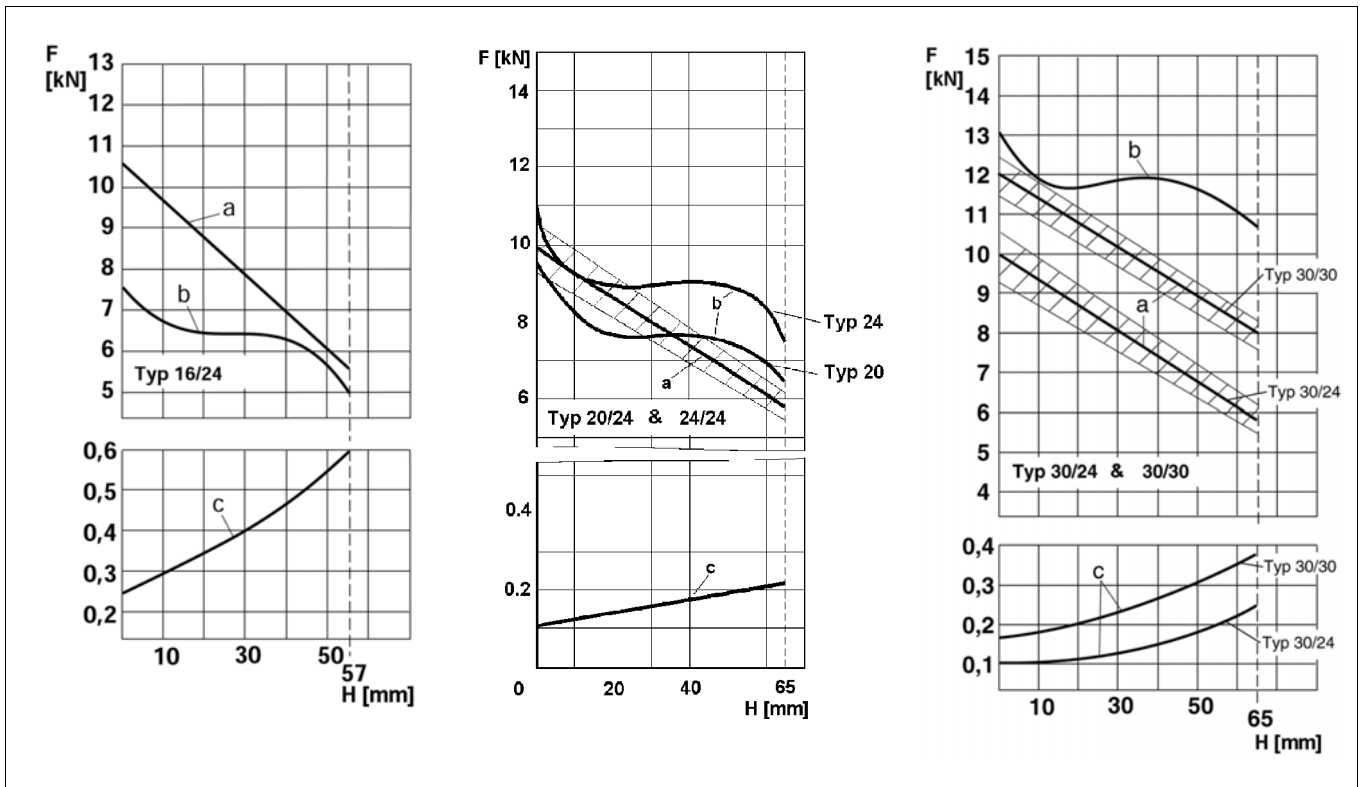

Key

- a Output force of the spring chamber, release pressure $p_e = 4.6 \pm 0.3$ bar F Force
- b Output force of the service brake part at $p_e = 6.5$ bar H Stroke
- c Return-spring force of the service brake part

Technical data

Order number	Type	Max. stroke [mm]
925 384 001 0	16/24	57
925 380 101 0	20/24	64

Max. operating pressure	8.5 bar
Volume-stroke of the brake chamber at 2/3 stroke [litres]	0.51
Volume stroke of the spring brake cylinder [litres]	0.754
Min. nominal diameter	Ø 11.5
Thermal range of application	-40 °C to +80 °C
Weight	6.6 kg

Install dimensions – Tristop® Cylinder (disc brake)

925 464 500 0

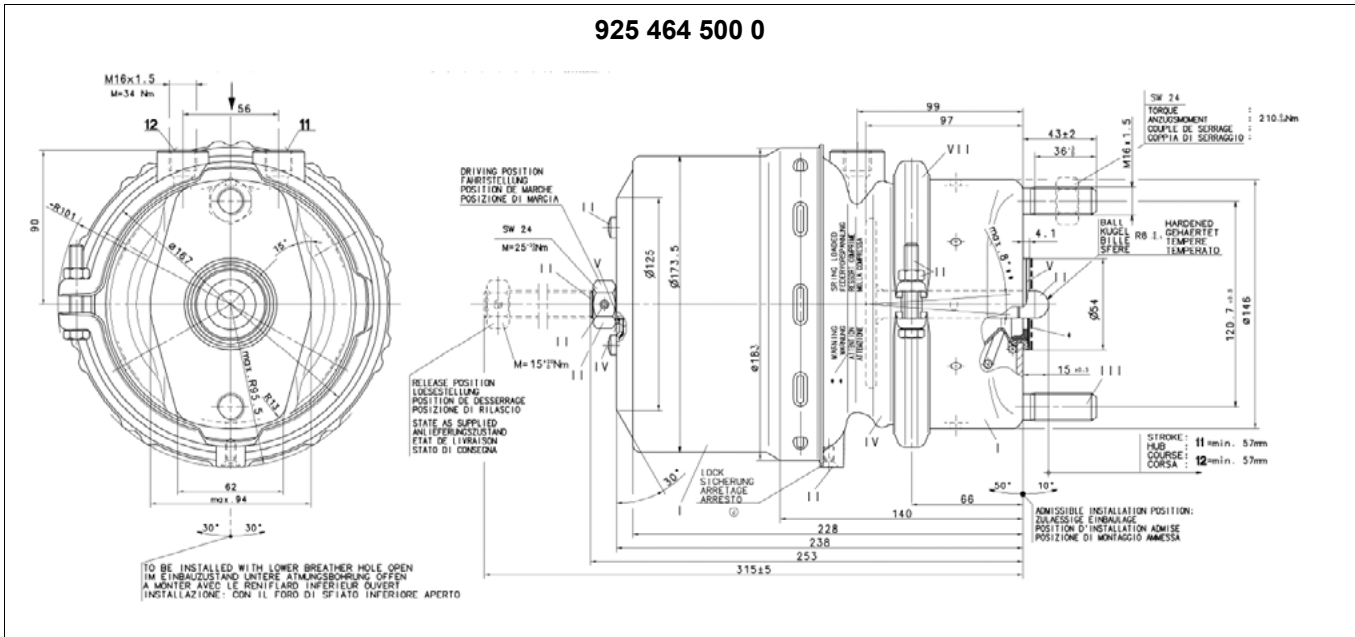

Port threads	Key
M 16x1.5	A In mounted position lower breather hole $\pm 30^\circ$ B Sphere C Out of plane D Release position as supplied E Permissible fitting position H Stroke L Left R Right

Type	Install dimensions [mm]													
	L ₁	L ₂	L ₃	L ₄	L ₅	L ₆	L ₇	L ₈	D ₁	D ₂	D ₃	R ₁	α	β
16/16	320	252	237	227	64	90	96	90	146	167	158.5	101	45°	90°
16/24	318	253	237	227	64	92	96	90	146	167	173.5	101	45°	90°
18/24	328	258	243	233	65	96	99	90	153	175	173.5	106	36°	90°
20/24*	328	258	243	233	65	96	99	90	153	175	173.5	106	45°	90°
20/24**	320	253	238	229	65	92	98	90	153	175	173.5	106	90°	110°

Key	
* 925 480 960 0	** 925 460 032 0

Technical data – Tristop® Cylinder (disc brake)

α= right β = left	Order number		Type	Max. stroke [mm]	Volume-stroke of the brake chamber at 2/3 stroke [litres]	Volume stroke of the spring brake cylinder [litres]	Max. operating pressure Service brake system Spring brake cylinder	Thermal range of application	Weight [kg]
	α = left β = right	Universal: Ports upwards β = left							
	925 464 450 0	925 464 451 0	16/16	57	0.54	1.2	10 bar 8.5 bar	-40 °C to +80 °C	7.0
	925 464 461 0 α = 90°. β = 70°		16/16	57	0.54	1.2			7.0
	925 464 500 0	925 464 501 0	16/24	57	0.54	1.4			8.0
	925 463 500 0	925 463 501 0	18/24	64	0.8	1.4			9.1
	925 460 100 0	925 460 101 0	20/24	64	0.8	1.4			9.2
		925 460 032 0	20/24	57	0.6	1.4			8.0
	925 461 050 0	925 461 051 0	24/24	64	0.8	1.4			9.2

Pressure diagram – Tristop® Cylinder (disc brake)

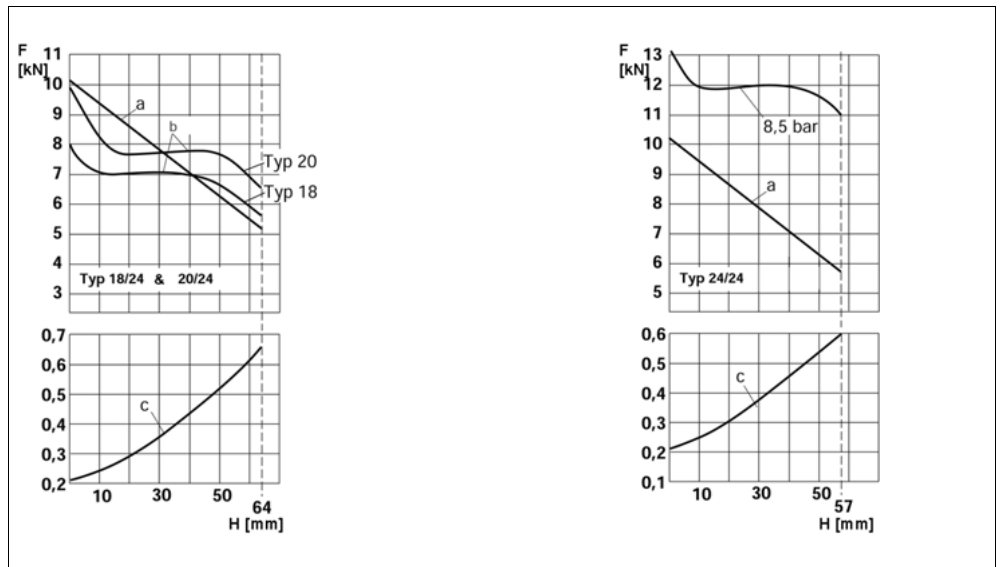

Key			
H	Stroke	F	Force

5.28 Drain valve 934 300 / 934 301

**Application**

On drain and pressure reservoirs.

Purpose

Protection of the compressed-air equipment from ingress of condensate by means of automatic or manual draining of the air reservoir.

Maintenance**Drain valve 934 300**

- If the valve does not close or open upon actuation, it must either be cleaned or replaced.

Automatic drain valve 934 301

Special maintenance that extends beyond the legally specified inspections is not required

Installation recommendation**Drain valve 934 300**

- Equip the drain valve with a seal ring A 22x27 DIN 7603 AI, order number 811 401 080 4 and thread it into the base connection for the air reservoir (tightening torque = 45 Nm).
The actuating pin is provided with a hole for attaching the pull-wire (934 300 003 0 with actuating ring).
- Do not mount any devices under the drain valve to ensure that the condensation will not become contaminated when draining.

Automatic drain valve 934 301

Special maintenance that extends beyond the legally specified inspections is not required

Installation dimensions

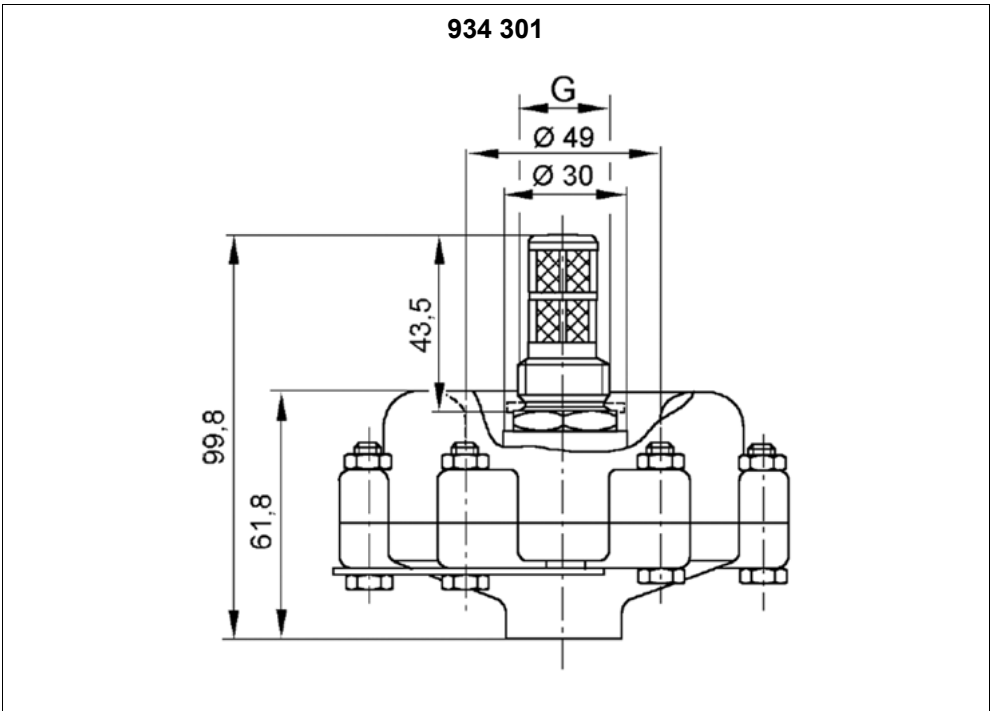
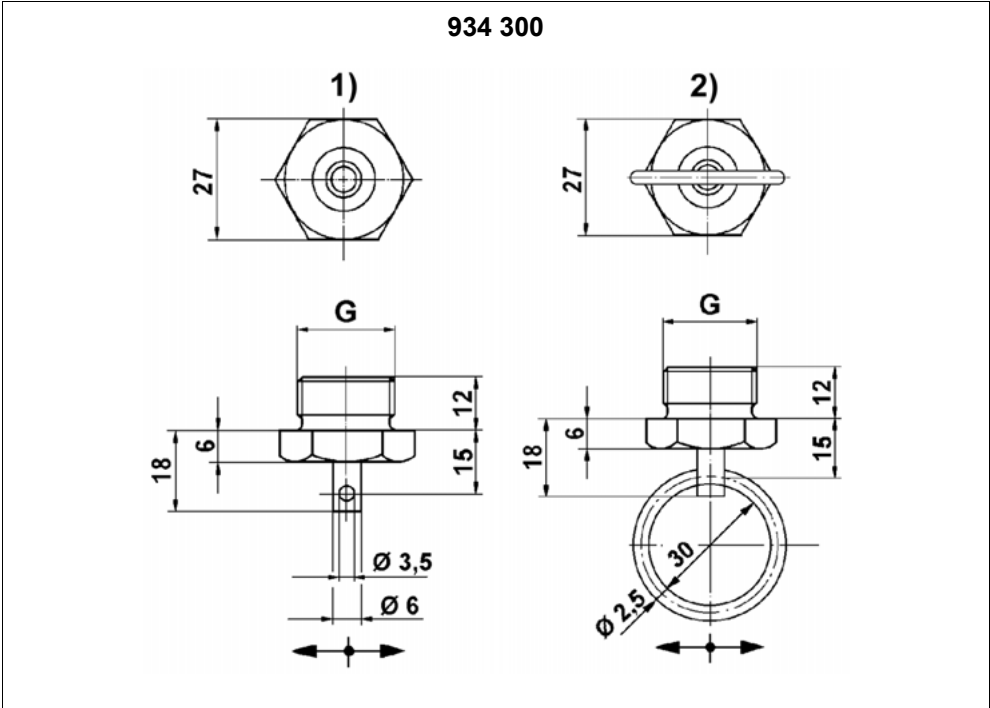

Technical data

Order number	934 300 001 0	934 300 002 0	934 300 003 0
Max. operating pressure	22 bar	20 bar	
Version (see Fig. "Installation Dimensions")	1)		2)
Port thread G (see Fig. "Installation Dimensions")	M 22x1.5	R 1/2" DIN 259	M 22x1.5
Permissible media	Air, water, mineral oil		
Thermal range of application	-40 °C to +80 °C		
In accordance with standard	B DIN 74 292	–	C DIN 74 292
Material	Brass		
Weight	0.05 kg	0.06 kg	0.05 kg

Order number	934 301 000 0
Max. opening pressure	20 bar
Port thread G (see Fig. "Installation Dimensions")	M 22x1.5
Permissible media	Air, water, mineral oil
Thermal range of application	-40 °C to +80 °C
Weight	0.46 kg

5.29 Air reservoir 950 ...



Application

For all vehicles with compressed air braking systems.

Purpose

Storage of the compressed air delivered from the compressor.

Design

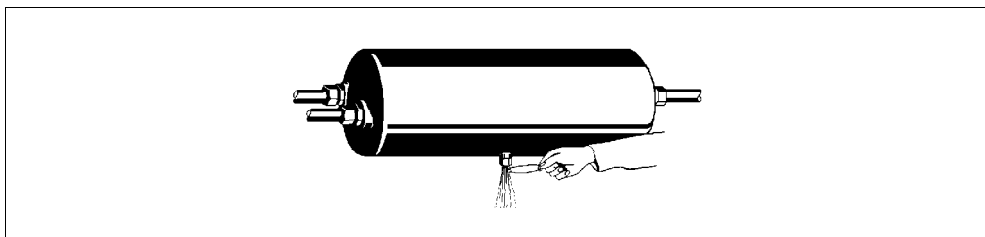

The reservoir consists of the cylindrical portion in the centre with welded-in arched bases and screw necks for connecting pipes.

A further port is located at the centre section where a draining facility can be attached for regular draining of condensate.

The material used is sheet steel to specification R St 37-2. The inside surface of the reservoir is coated with a synthetic resin to provide protection against corrosion. The outside surface is primed with a synthetic resin.

A plate is located at one end, indicating the name and address of the supplier, the supplier's part number, the year of manufacture, the maximum operating pressure [bar], the capacity [litres], the serial number, test mark, the volume x diameter and – for some types only – DIN 74 281.

Maintenance

- Drain the air reservoir daily.



We recommend using drain valves which are available for both manual and automatic actuation.

Installation recommendation

- Attach the clamp rings so that the connecting seams do not touch the base and the reservoir is not subjected to any tension that could jeopardize operational safety.
The fastening is done using straps or the brackets of the reservoir.
Put insulation strips between the reservoir and the straps if necessary.

- Install the reservoir horizontally or vertically.
Make sure that one drain pipe is located at the lowest point of the reservoir.
Make sure that any condensation can be emptied and/or the collection of condensation is prevented.
→ The reservoir plate must be easily legible in the specified installation point when the reservoir is installed.

! No heat treatment or welding is to be done on the walls of the reservoir that are under pressure.

Installation dimensions

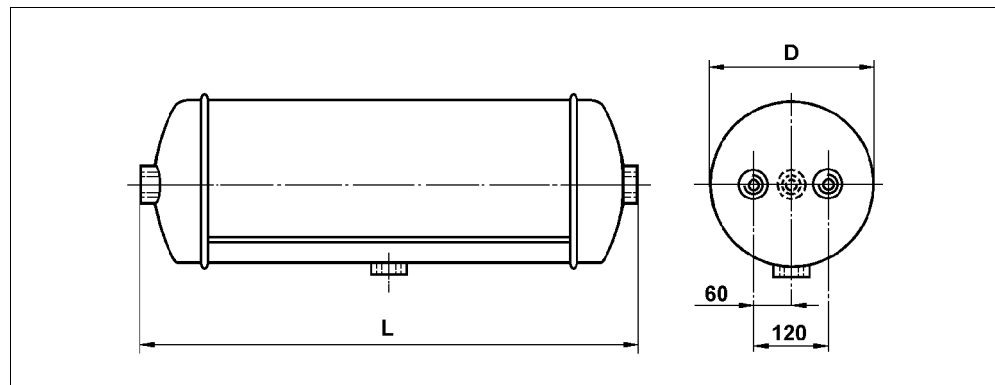

Port threads

M 22x1.5 - 12 deep

Technical data

Order number	Contents [litres]	Length L [mm]	Diameter D [mm]	Max. operating pressure [bar]	Weight [kg] ±10 %
950 405 001 0	4.5	185	206	15.5	3.0
950 410 004 0	10	368	206	15.5	4.7
950 420 003 0	20	691	206	15.5	8.0
950 520 003 0	20	495	246	15.5	7.2
950 530 002 0	30	709	246	15.5	10.0
950 537 001 0	37	862	246	15.5	11.9
950 540 001 0	40	927	246	15.5	12.7
950 740 002 0	40	758	276	14.5	11.5
950 560 002 0	60	1365	246	15.5	18.0
950 760 002 0	60	1108	276	14.5	16.2
950 060 003 0	60	893	310	12.5	15.2
950 060 004 0	60	580	396	12.5	16.3
950 080 002 0	80	750	396	12.5	20.5
950 100 002 0	100	915	396	12.5	24.5

Clamping band	Cylinder Ø	Order number
	206	451 999 206 2
	246	451 999 246 2
	276	451 999 276 2
	310	451 999 310 2
	396	451 999 396 2

Rubber spacer: 451 999 999 0 (50 m roll)

5.30 Hose coupling 952 20. / 452 ...

Hose coupling 952 20. / 452 ...

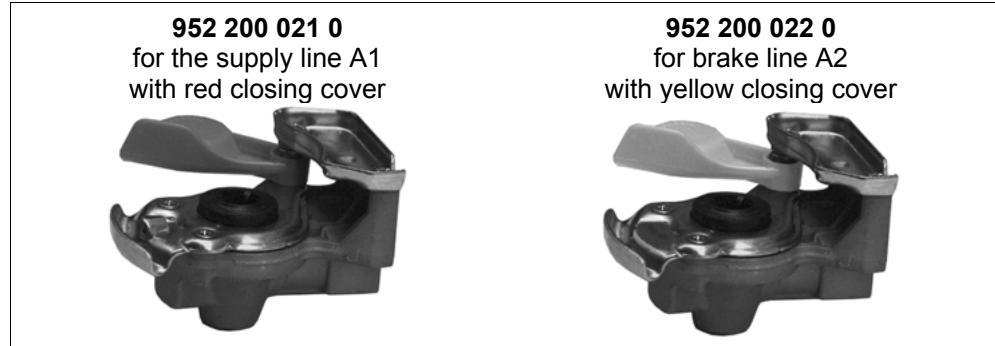

Application

In the supply- and brake-line between the truck and the trailer.

Purpose

Connect the two lines with cross-coupling safeguard.
The hose couplings conform to the ISO 1728 standard.

Maintenance

Special maintenance that extends beyond the legally specified inspections is not required.



If automatic hose couplings are used, the shut-off cock normally required is not required.

Whenever the trailer parts from its truck, the lines will always rupture. The hose couplings do not become disconnected.



After unhitching the vehicle, the plastic cover (red or yellow) must be screwed onto the coupling head opening to prevent dirt from entering.

Test

For leakages only.

Technical data

Order number	952 200 021 0	952 200 022 0
Design	For the supply line A1 with red closing cover and an axial safeguard against cross-coupling	For brake line A2 with yellow closing cover and a lateral safeguard against cross-coupling
Method of utilisation	Semitrailer	Truck Truck tractor
Max. operating pressure	10 bar	
Thermal range of application	-40 °C to +80 °C	
Weight	0.22 kg	0.18 kg

Dummy Coupling: Order number 452 402 000 0

Overview

! Hose couplings of the older 452 200 series can be connected to hose couplings of the 952 200 series without any problem.

		Coupling heads		
Truck	Trailer	Thread	Colour	Comment
For Swiss type brake systems				
452 303 031 0	452 203 031 0	M 22x1.5	red	Supply line
452 303 032 0	452 203 032 0	M 22x1.5	yellow	Control line
Dual-line braking system				
	452 200 000 0	M 22x1.5	–	without closing cover
	452 200 004 0	M 22x1.5	Black	Black closing cover
452 200 211 0	452 200 011 0	M 22x1.5	red	Supply
952 200 221 0	952 200 021 0	M 16x1.5		
452 200 212 0	452 200 012 0	M 22x1.5	yellow	Control line
952 200 222 0	952 200 022 0	M 16x1.5		
	952 200 040 0	M 16x1.5 with test connection	yellow	Control line
952 200 210 0		2x M 16x1.5	red	Supply
Duo-Matic				
452 802 009 0	452 804 012 0	M 22x1.5 / M 16x1.5		Truck / Trailer
452 805 004 0	452 803 005 0	M 22x1.5 / M 16x1.5		Truck tractor / Low-bed
452 802 007 0	452 803 004 0	M 22x1.5 / M 16x1.5		Truck tractor / Low-bed (with quick-connect)

Using doubled pipe 893 100 138 4, the coupling head with an M 22x1.5 thread can be replaced with a head with an M 16x1.5 thread.

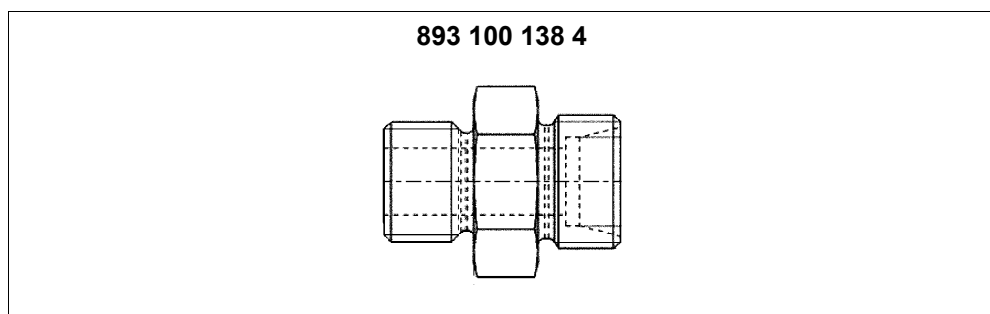

Installation dimensions

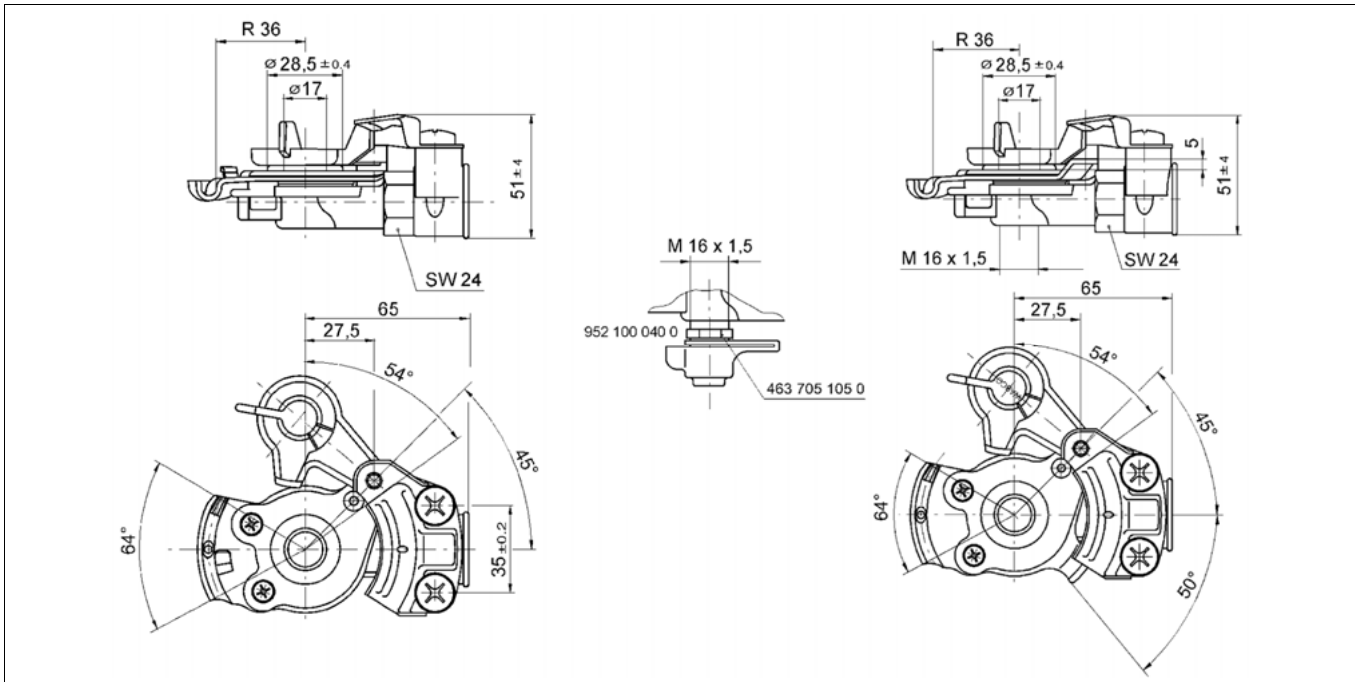

Installation recommendation

The hose couplings must be installed according to ISO 1728, see the following drawings.

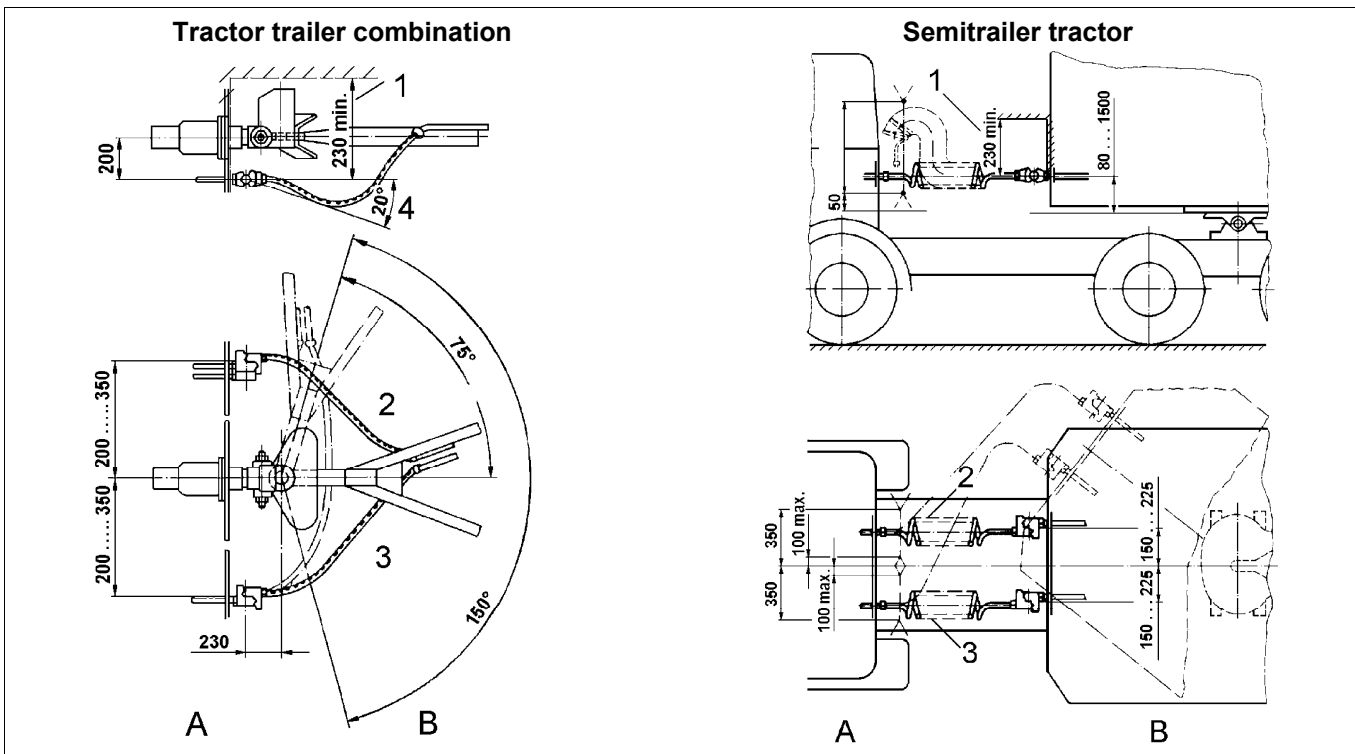

Key

- | | | | | | | | |
|---|-------------------------|---|-------------|---|--------------|---|--------------------------------|
| 1 | Free space for coupling | 2 | Supply line | 3 | Control line | 4 | Max. deviation from horizontal |
|---|-------------------------|---|-------------|---|--------------|---|--------------------------------|

Schematic for installation

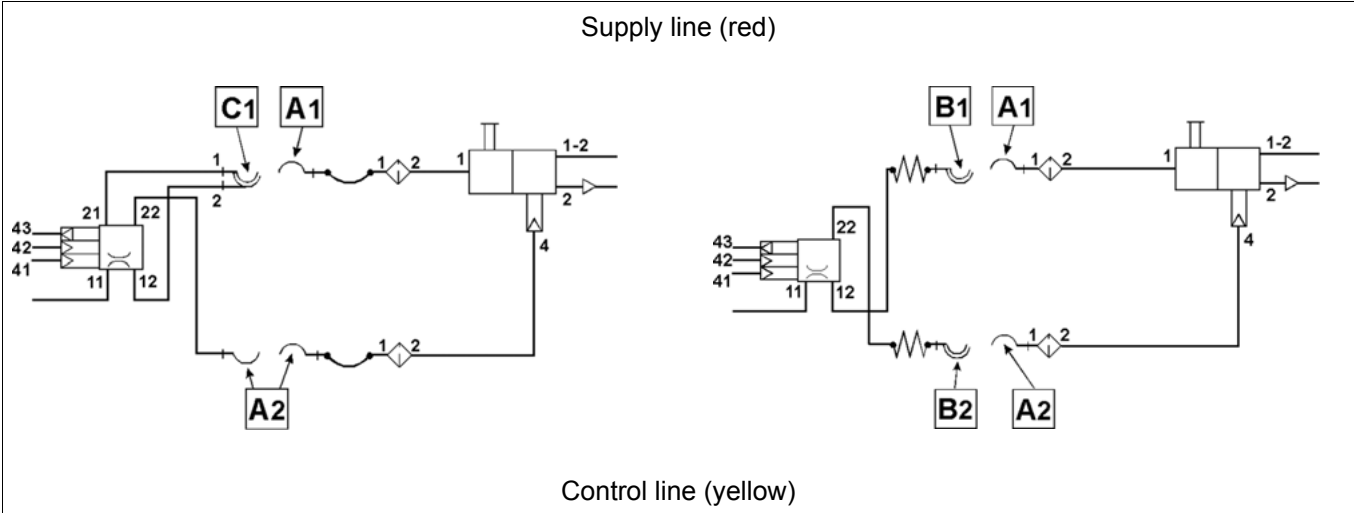

Hose coupling with integrated line filters 952 201

Application

In the supply- and brake-line between the truck and the trailer.

Purpose

When making the coupling, the hose couplings on the truck and the trailer are connected with one another. This occurs by twisting and interlocking the opposing guides at the same time.

An additional line filter is not required.



Combining important functions in a single product.

Advantages: less accessories, lower space requirements, less parts, quick and easy installation.

Installation dimensions

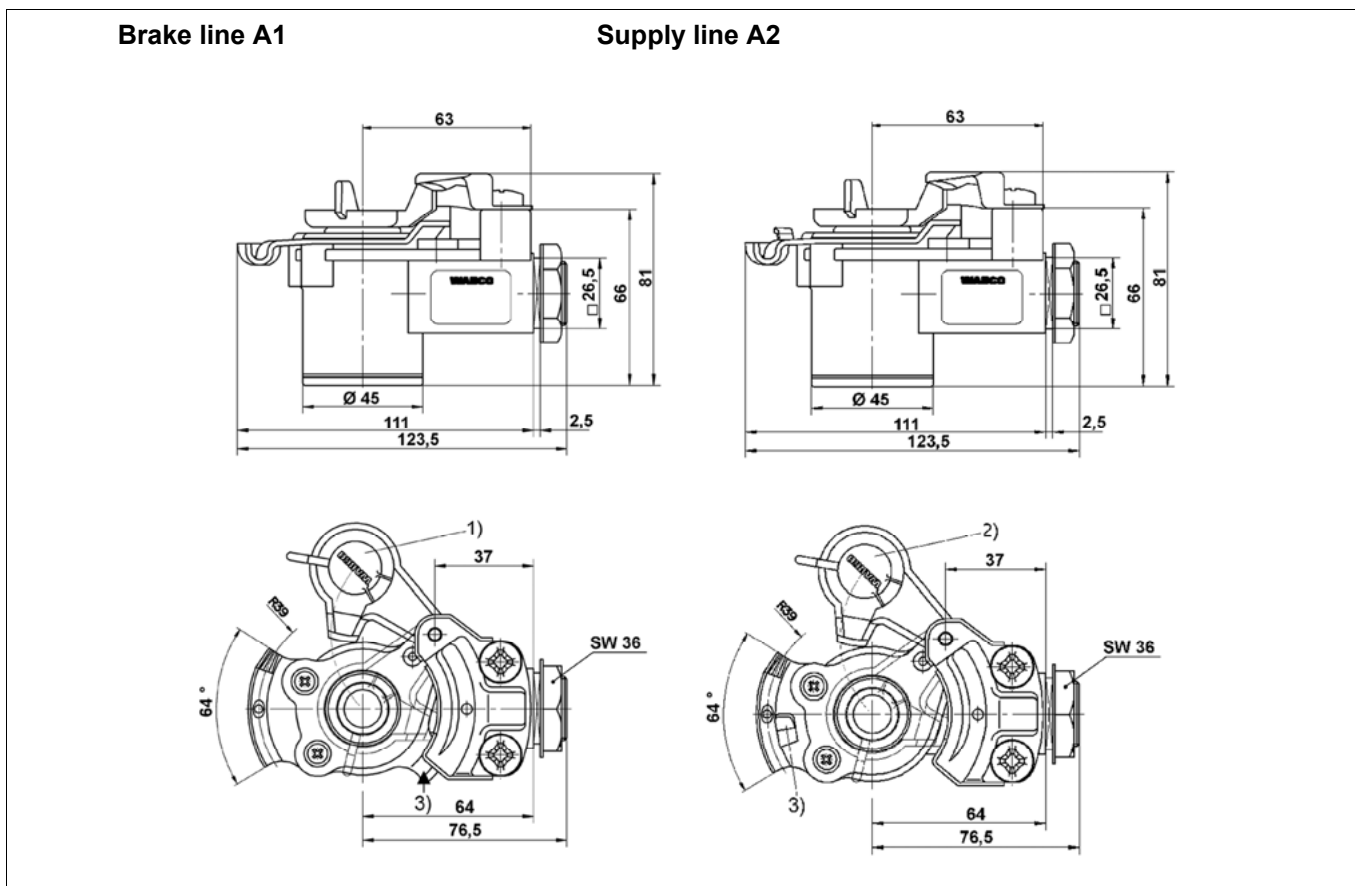

Port threads

Z = M 16x1.5

Key

1) Yellow cap

2) Red cap

3) Anti-mismatch device

Technical data

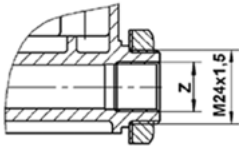
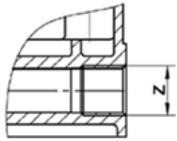
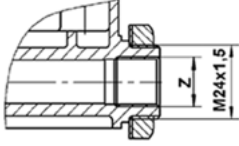
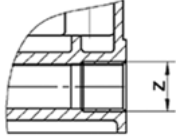
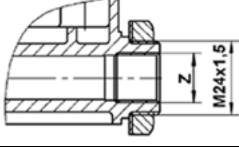
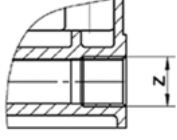
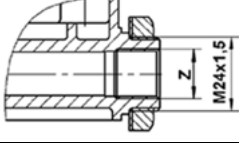
Order number	Design		Variant	Max. operating pressure	Thermal range of application
	Supply line (Red cap)	Control line (Yellow cap)			
952 201 001 0		X		8.5 bar	-40 °C to +80 °C
952 201 003 0		X			
952 201 002 0	X				
952 201 004 0	X				
952 201 007 0		X			
952 201 008 0		X			
952 201 011 0		X			
952 201 012 0	X				
952 201 013 0		X			
952 201 014 0		X	Only outer thread		
952 201 015 0	X		No thread		
952 201 016 0	X				
952 201 017 0		X			

5.31 Trailer release valve 963 001 / 963 006

**Application**

For trailers

Purpose

Release the brake system to move the semitrailer when not coupled.

Maintenance

Special maintenance that extends beyond the legally specified inspections is not required.

Installation recommendation

- Mount the trailer release valves 963 006 001 0, 963 006 003 0, 963 006 005 0 and the double release valves 963 001 051 0 and 963 001 053 0 so that they can be easily accessed in the frontal area of the trailer.



Flange the trailer release valve 963 001 012 0 and 963 001 013 0 directly onto the trailer emergency brake valve.

- Install the trailer release valve vertically so that the actuation button faces downward.
Permissible installation position: $\pm 90^\circ$
- Fasten the trailer release valve with two M8 bolts.

Installation dimensions

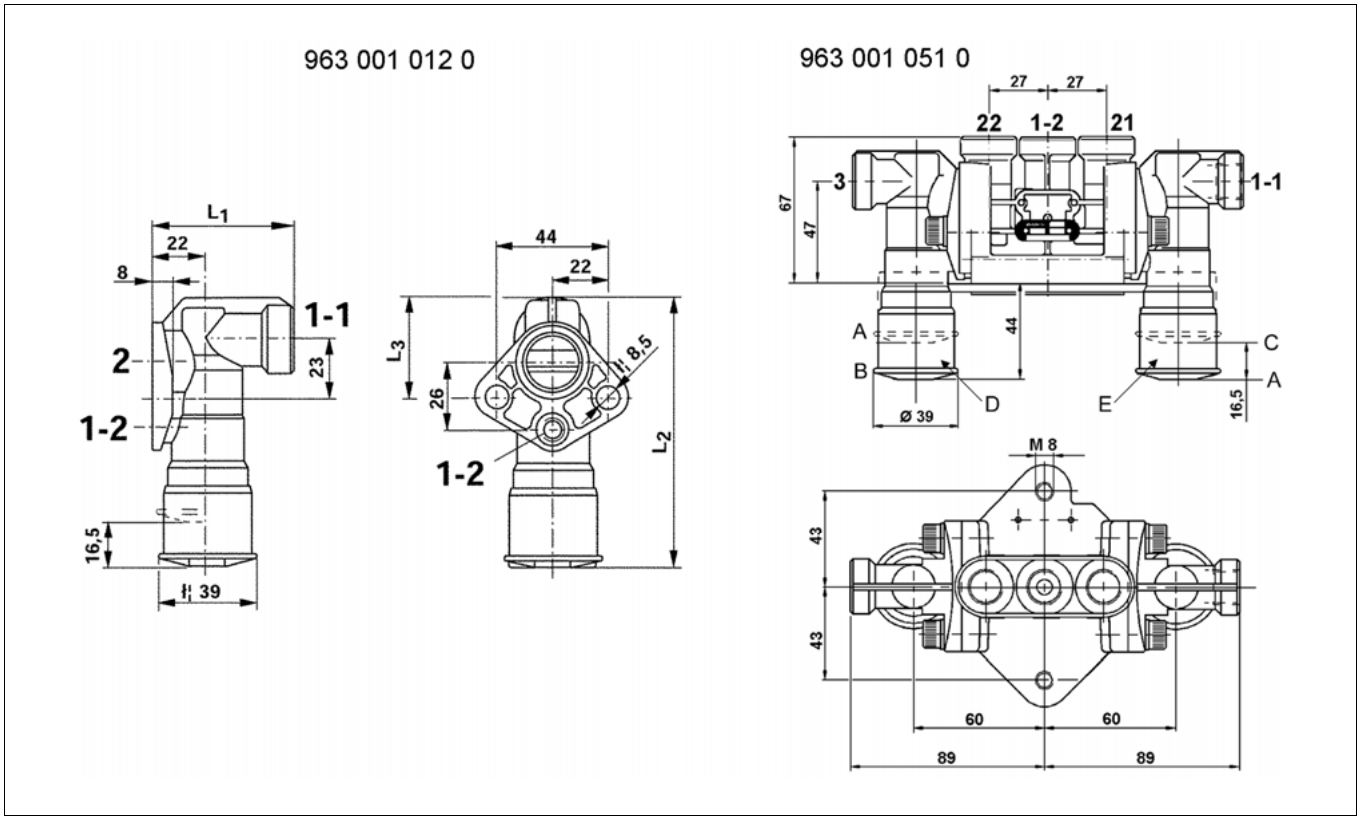

Connections		Port threads		Key	
1-1	Energy supply	1-2	Energy supply (Reservoir)	M 16x1.5 - 12 deep	A Driving position D Black actuation button
2	Energy delivery	3	Exhaust		B Parking position E Red actuation button
21	Energy delivery (Trailer emergency brake valve)	22	Energy delivery (Spring brake cylinder)		C Release position

963 006 001 0

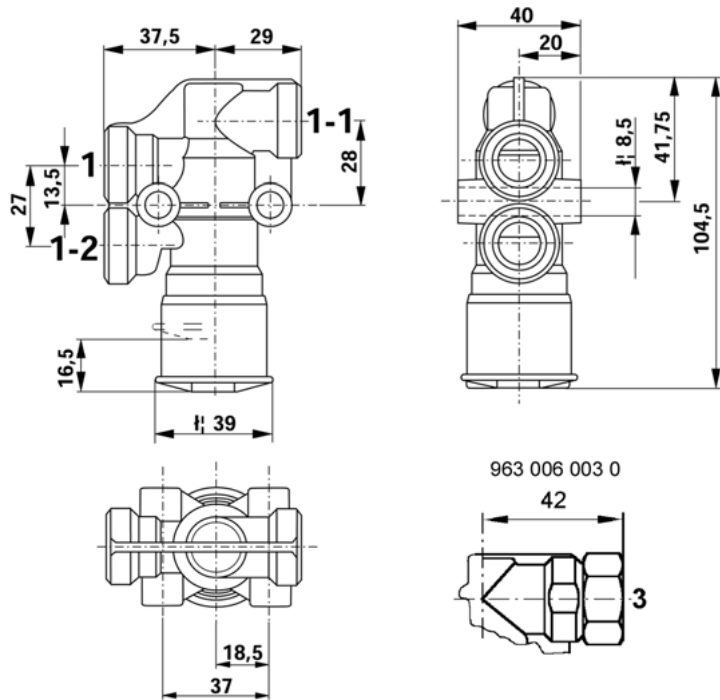

Connections

1-1	Energy supply	1-2	Energy supply (Reservoir)	2	Energy delivery
-----	---------------	-----	---------------------------	---	-----------------

Technical data

Order number	963 001 012 0	963 001 013 0	963 001 051 0 963 001 053 0	963 006 001 0	963 006 003 0	963 006 005 0
Max. operating pressure	8.5 bar					
Min. nominal width 1-1 => 2	Ø 8		–		Ø 8	
Min. nominal width 1-2 => 2	Ø 6		–		Ø 6	
Port threads	M 16x1.5 - 13 deep	M 22x1.5 - 13 deep		M 16x1.5 - 13 deep		
Installation dimensions L ₁	51 mm	54.5 mm		–		
Installation dimensions L ₂	104.5 mm	107 mm		–		
Installation dimensions L ₃	36.7 mm	39 mm		–		
Colour of the actuation button	Black		Two buttons: Black/red	Black	red	green
Permissible medium	Air					
Thermal range of application	-40 °C to +80 °C					
Weight	0.13 kg	0.21 kg	0.73 kg	0.15 kg		

- !** The trailer release valve 963 006 003 0 has a red actuation button, in connection 1-1 a venting valve and is suitable for Tristop® cylinders like the double release valve 963 001 051 0.
The trailer release valve 963 006 005 0 is identical to the 963 006 003 0 but with a green actuation button for lift axles.

Plates with parking and driving symbols

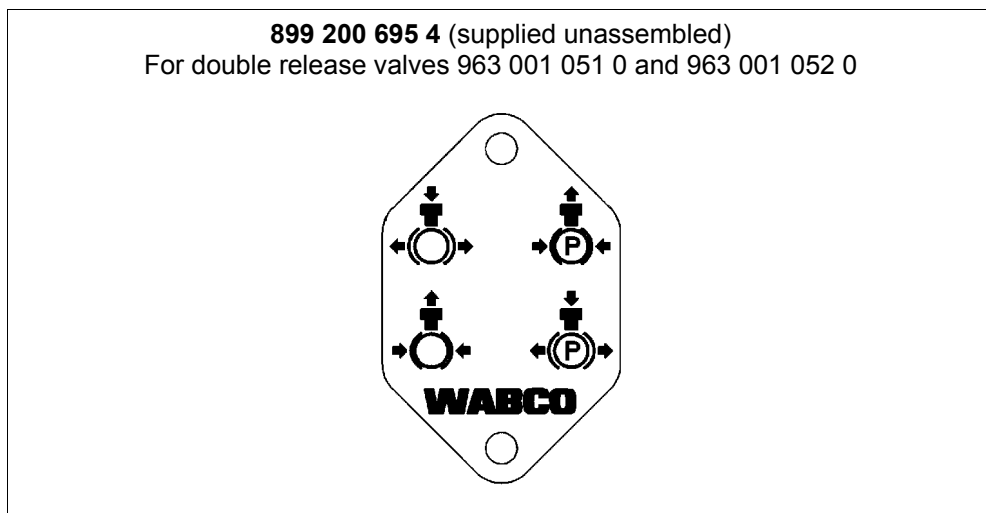

5.32 Shut-off valve 964 001**Application**

Vehicles with special equipment for dropping swap-trailers.

Purpose

Stroke limit on vehicles with lift equipment.

Maintenance

Special maintenance that extends beyond the legally specified inspections is not required.

Installation recommendation

- Install the shut-off valve so that the fastening bolts are only stressed in the longitudinal direction.

Installation dimensions

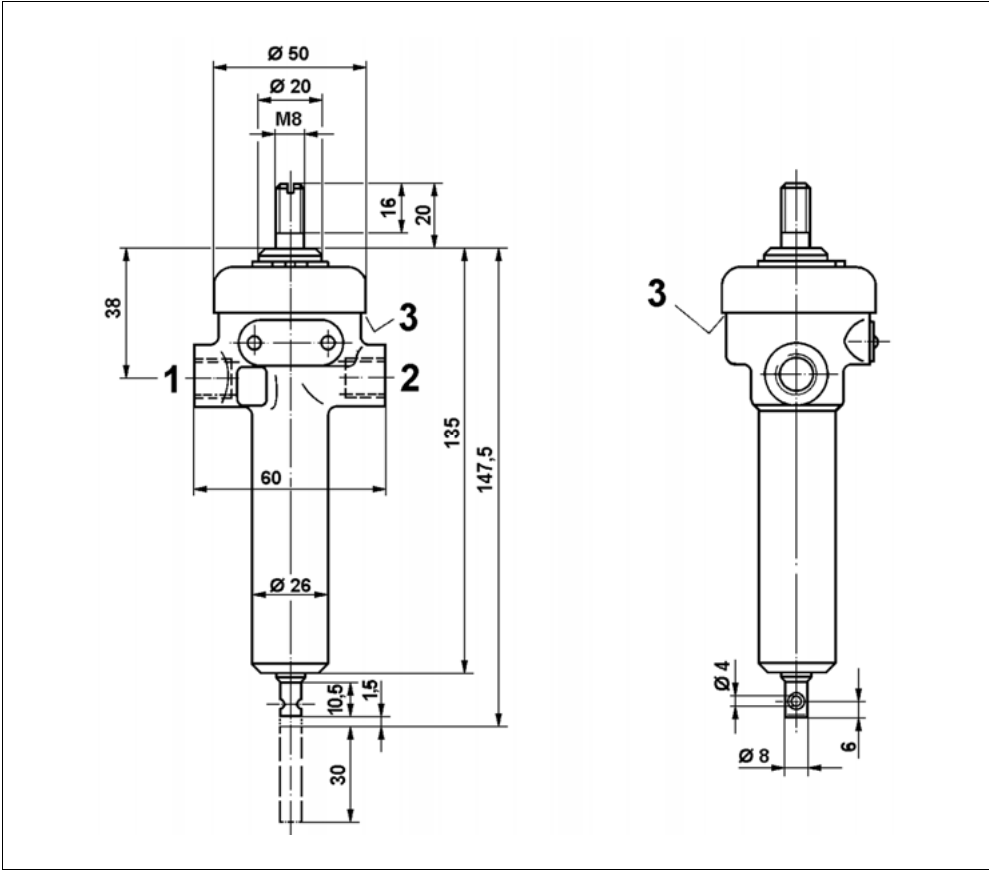

Schematic for installation

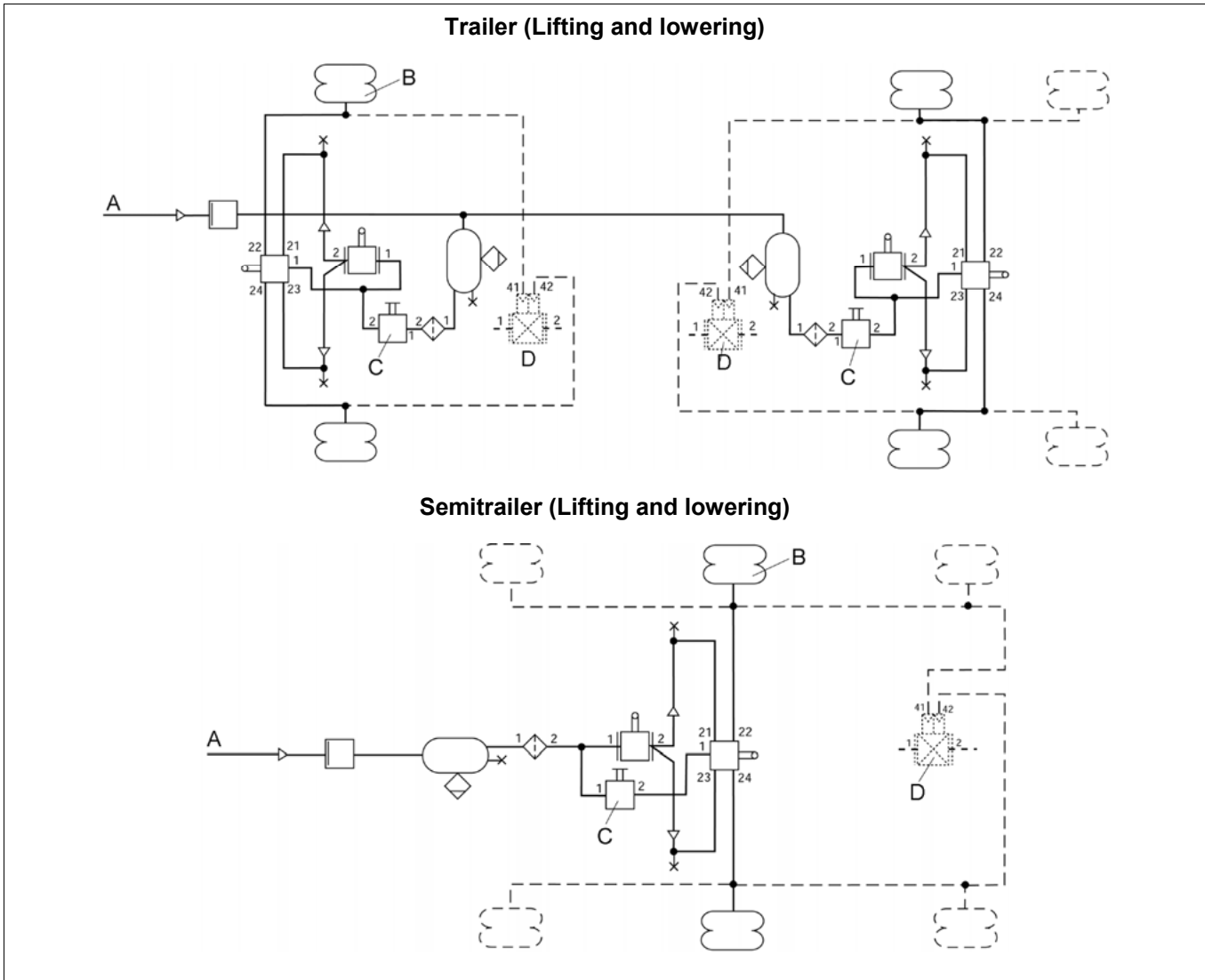

Key			
A	Supply, from the service brake system	B	Air suspension bellows
		C	Non-return valve
		D	SLV controller

Technical data

Order number	964 001 002 0
Max. operating pressure	12 bar
Nominal diameter	7 mm
Permissible medium	Air
Thermal range of application	-40 °C to +80 °C
Weight	0.4 kg

Diagram

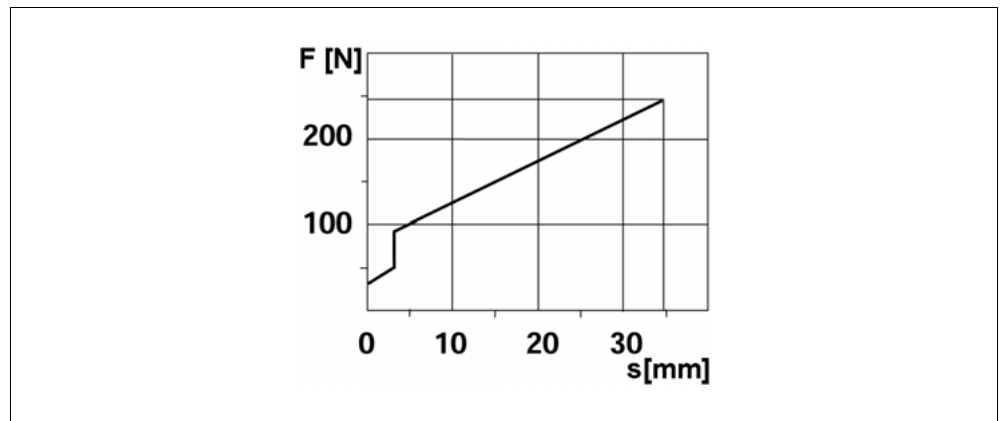

Key	
F	Actuating force
s	Tappet travel

5.33 Trailer control valve with adjustable predominance 971 002**Application**

Vehicles with conventional two-line brake control (not Trailer EBS).

Purpose

To control the dual-line air braking system of the trailer.

Maintenance

- Check the status of the filters in connection 4 and 1.
→ Replace the filter if necessary.

Installation recommendation

- Install the trailer brake valve vertically so that vent 3 faces downward.
- Fasten the trailer brake valve with two M10 bolts.

Installation dimensions

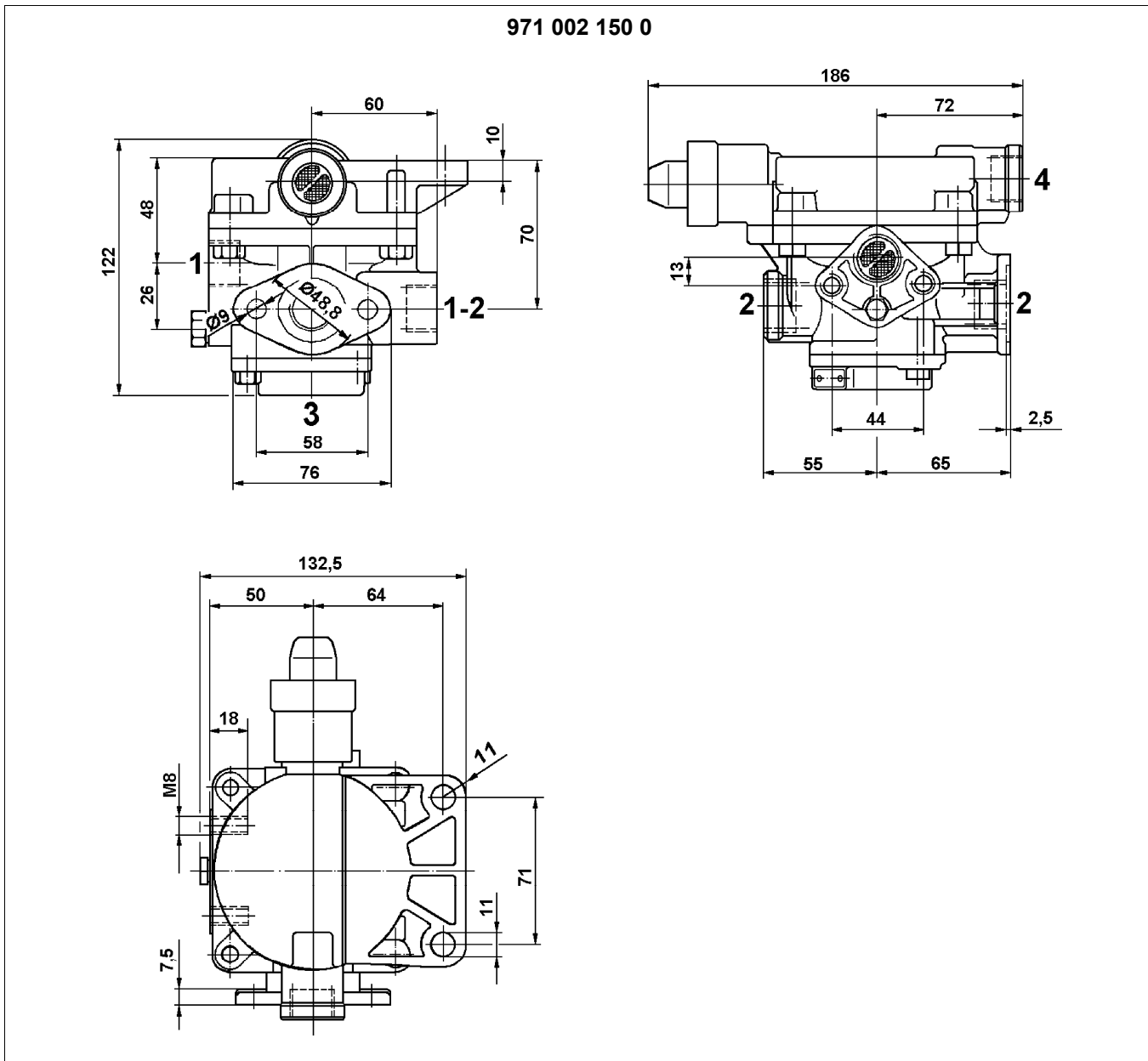

Connections		Port threads				
1	Energy supply	1-2	Energy supply or delivery (Reservoir)	4	Control port	M 22x1.5 - 15 deep
2	Energy delivery	3	Exhaust			

971 002 531 0: combination trailer brake valve 971 002 150 0 with release valve 963 001 012 0

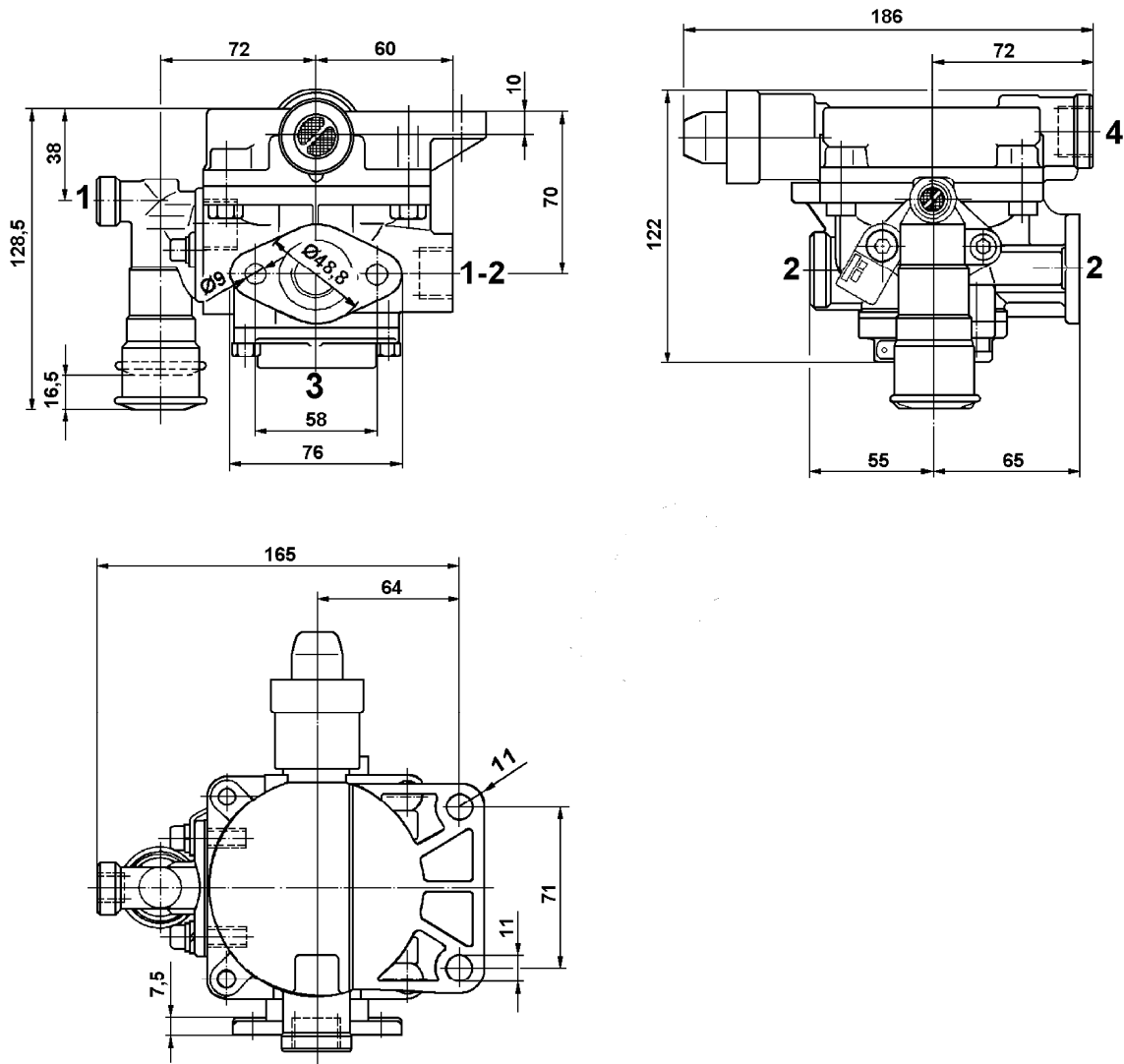

Connections

1	Energy supply	1-2	Energy supply or delivery (Reservoir)
2	Energy delivery	3	Exhaust

Port threads

4	Control port	M 22x1.5 - 15 deep
1		M 16x1.5 - 13 deep

When not in use, second port 2 must be closed using

Screw plug M 22x1.5
Seal washer A 22x27 DIN 7603-AI

Order number

893 010 070 4
811 401 080 4

971 002 570 0: Combination trailer brake valve 971 002 150 0 with load sensing valve 475 604 011 0

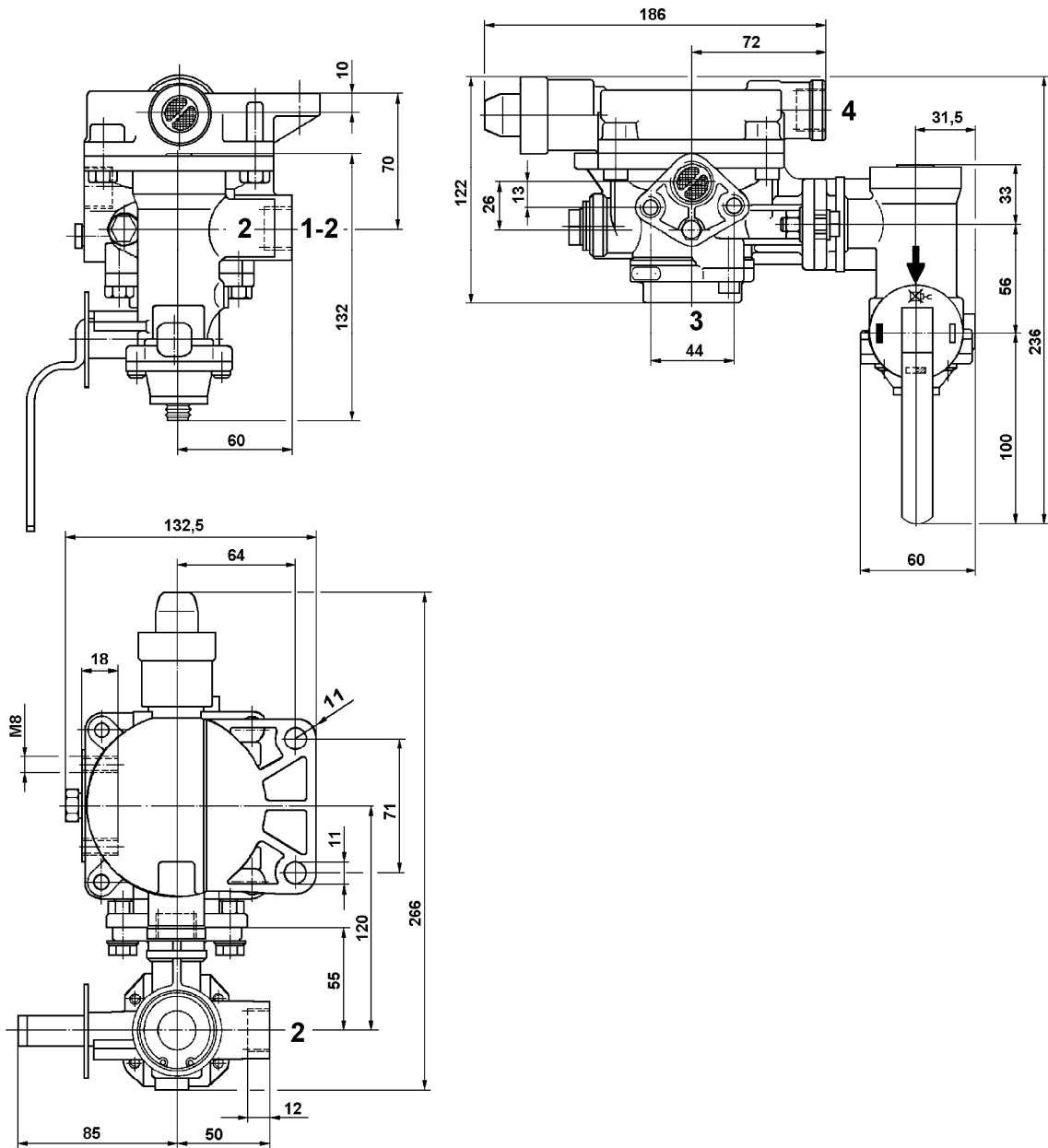

Connections			Port threads	
1	Energy supply	1-2	Energy supply or delivery (Reservoir)	M 22x1.5 - 15 deep
2	Energy delivery	3	Exhaust	
		4	Control port	

971 002 300 0

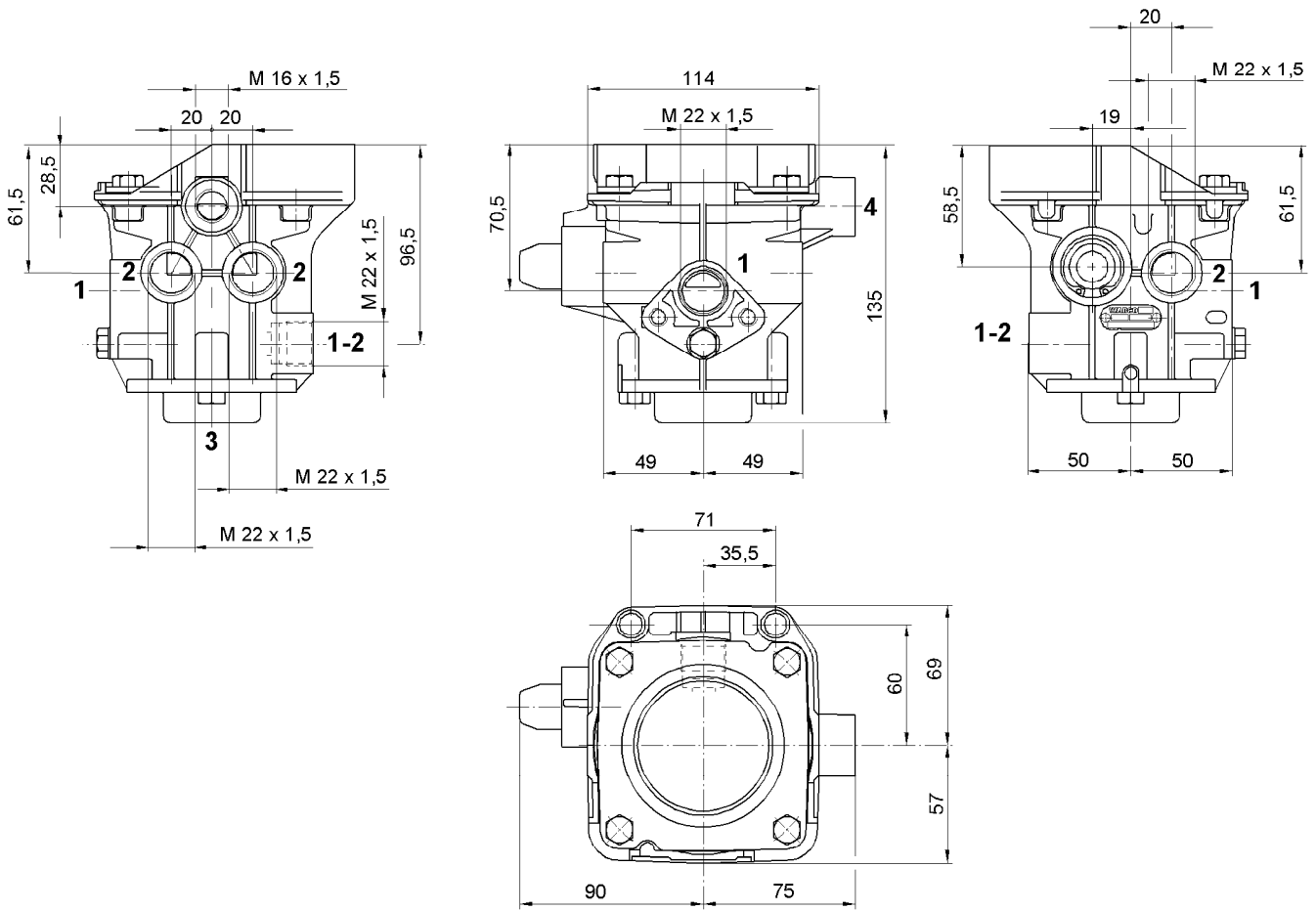

Connections

1-2	Energy supply or delivery (Reservoir)	1	Energy supply	2	Energy delivery	3	Exhaust	4	Control port
-----	---------------------------------------	---	---------------	---	-----------------	---	---------	---	--------------

Technical data

Order number	971 002 150 0	971 002 300 0	971 002 301 0
Max. operating pressure	10 bar	8.5 bar	
Factory setting of predominance	0 bar		without
Dead volume	0.205 litre	-	
Thermal range of application	-40 °C to +80 °C		
Port 4	-	M 16x1.5	
Weight	1.8 kg	1.4 kg	

Diagram

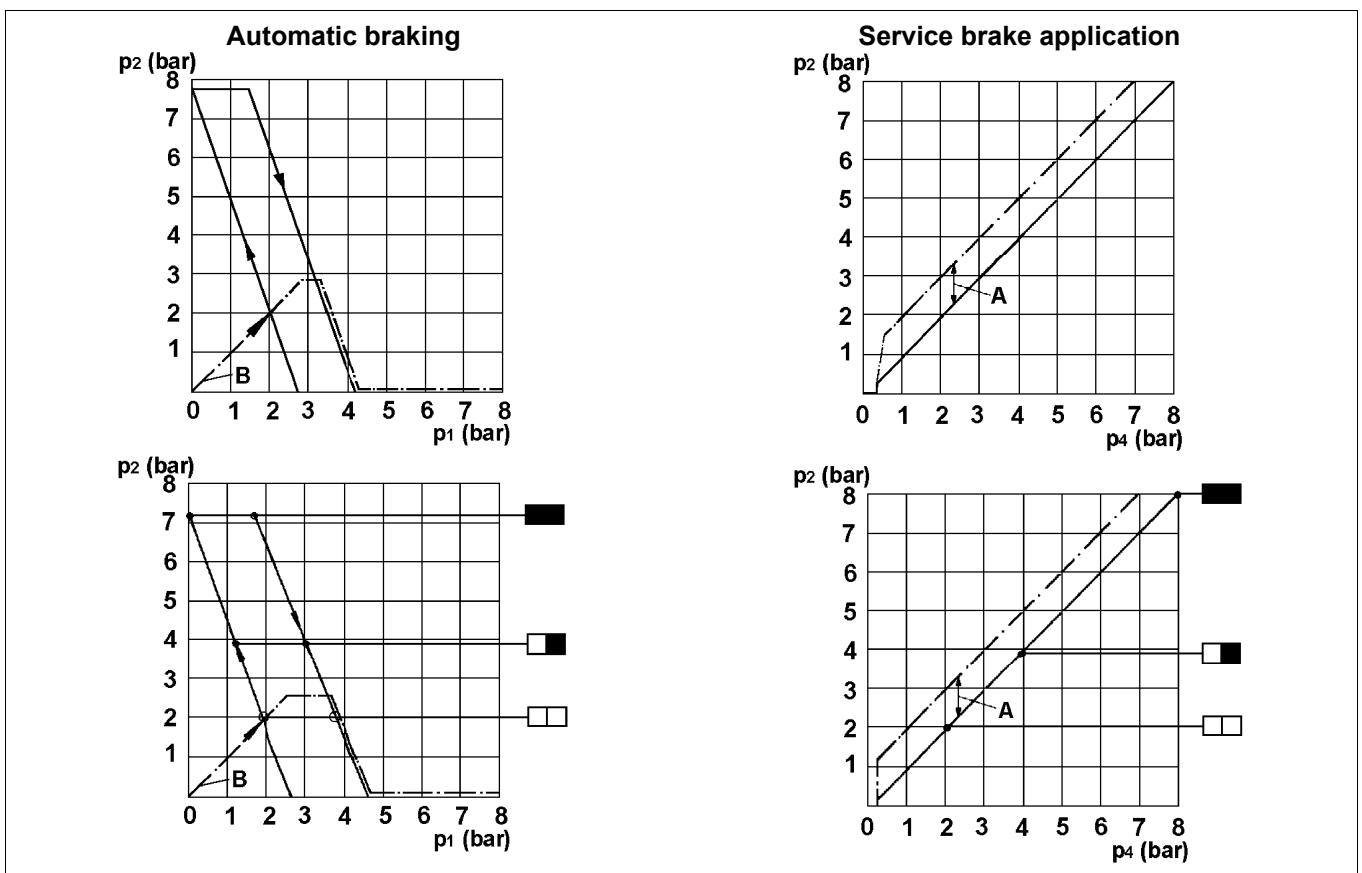

Key

p_1 Input pressure p_2 Output pressure p_4 Control pressure B Range of adjustment B Initial fill

Symbols	
	Release position
	Blank
	"Partially laden"
	Fully laden

Trailer brake valve 971 002 152 0**Application**

Application especially in long semitrailers with multiple axles.

Purpose

Control of the two-line semitrailer brake systems when actuating the braking system of the truck.

Triggering of the automatic semitrailer braking with partial or total pressure drop in the supply line.

Maintenance

- Check the status of the filters in connection 4 and 1.
→ Replace the filter if necessary.

Installation recommendation

- Install the trailer brake valve vertically so that vents 3 faces downward.
- Fasten the trailer brake valve with two M10 bolts.
The connection from connection 1-2 to the supply reservoir should be kept as short as possible and have the largest cross-section possible.

! On 3-axle semitrailers connect the four down-facing connections 2 (with thread M 16x1.5) directly with the four brake cylinders on the 1st and 2nd axles with hoses. Connect the 5th connection 2 (thread M 22x1.5) via a common line and then via separated hoses with the cylinders on the third axle.
On 2-axle semitrailers, connect the connection 2 with thread M 22x1.5 using a screw plug.
On 1-axle semitrailers, you must close off two other connection 2 with screw plugs M 16x1.5.

- Install a trailer release valve in the supply line between the hose coupling and the trailer brake valve.
- Install the LSV controller in the brake line before connection 4 of the trailer brake valve.

Installation dimensions

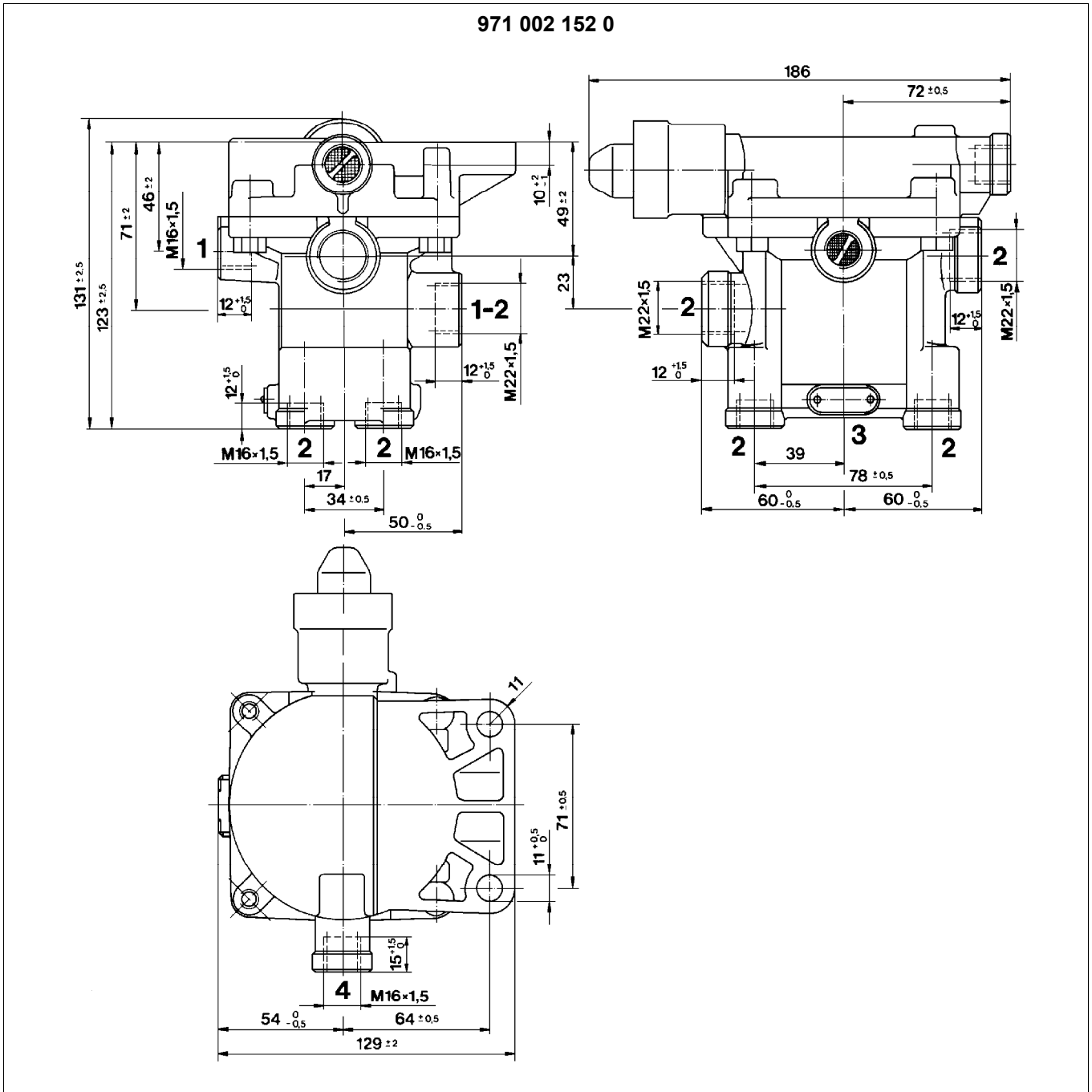

Connections

1-2 Energy supply or delivery (Reservoir)	1 Energy supply	2 Energy delivery	3 Exhaust	4 Control port
--	------------------------	--------------------------	------------------	-----------------------

Pressure diagrams

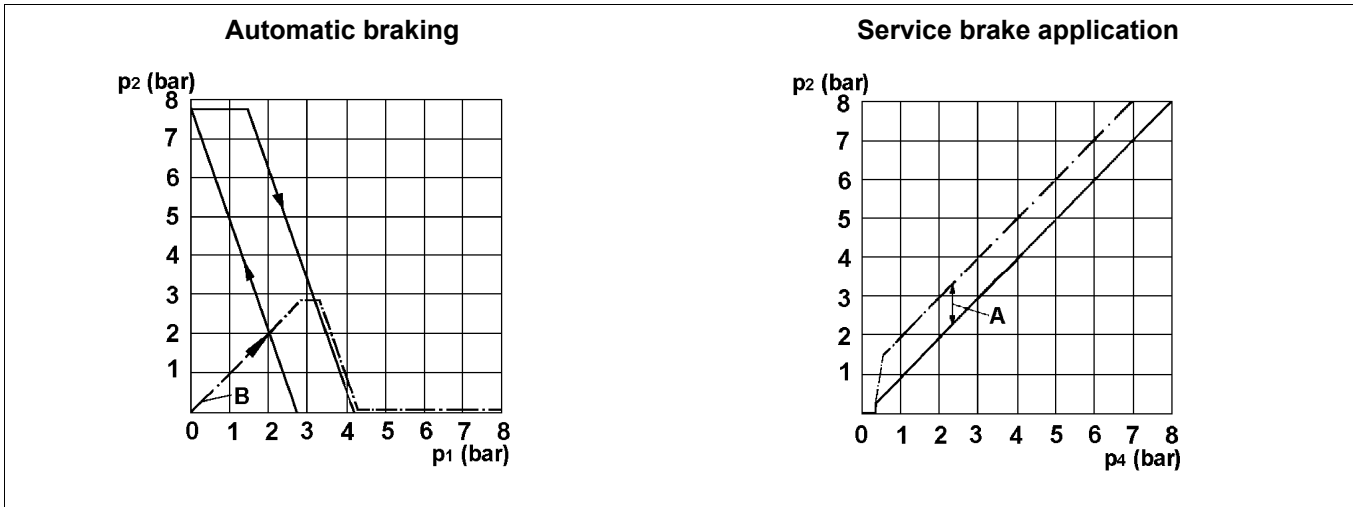

Key

p_1 Input pressure p_2 Output pressure p_4 Control pressure A Range of adjustment B Initial fill

Technical data

Order number	971 002 152 0
Max. operating pressure	10 bar
Dead volume	0.205 Litres
Thermal range of application	-40 °C to +80 °C
Weight	1.66 kg

5.34 Park-release emergency valve (PREV) 971 002



Application

Vehicle with Trailer EBS version D and E

Purpose

The park release emergency valve replaces the trailer emergency valve and the twin release valve, used till now in the trailer braking systems of the EBS D generation. This valve simplifies the trailer braking system by the elimination of one device and realises the functions typically for the trailer braking valve, as rupture function or pressure restraint when the (semi-)trailer has been unhitched.

Installation diagram – Trailer EBS E

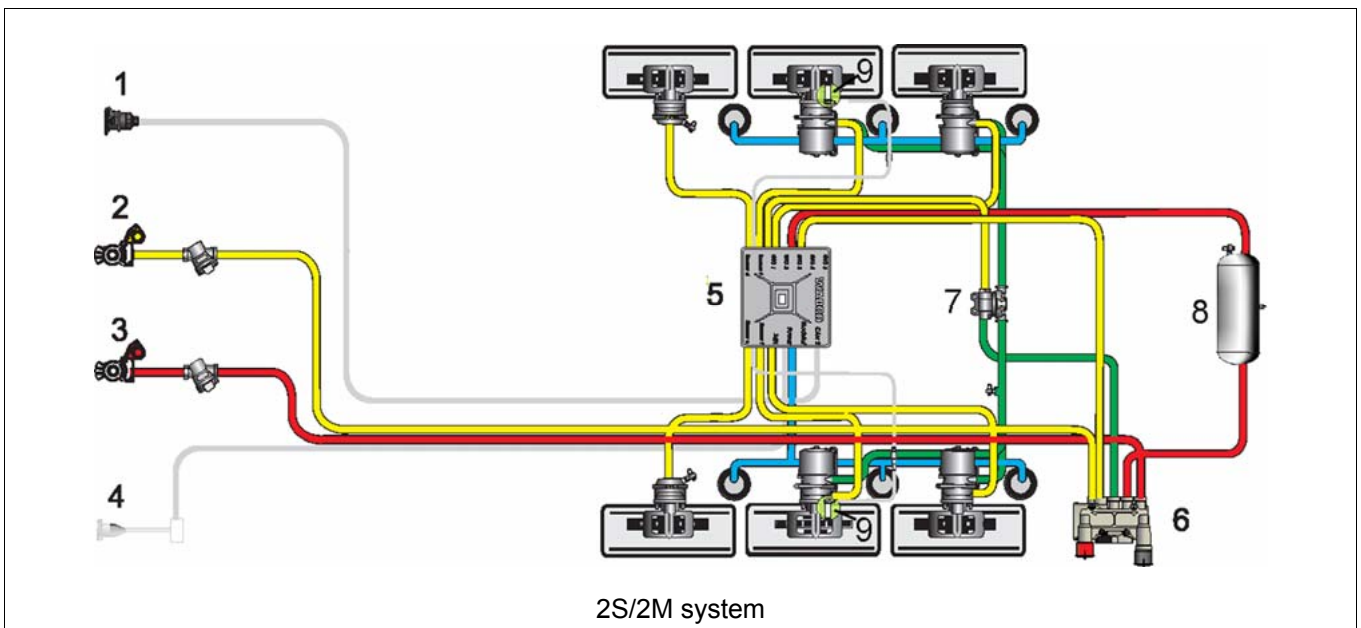

Key

1 Voltage supply via ISO 7638	2 Control line	3 Supply line
4 Stop light supply via ISO 1185 (optional)	5 Trailer EBS E Modulator	6 Park-release emergency valve (PREV)
7 Overload protection valve	8 Tank	9 Sensors

Installation dimensions

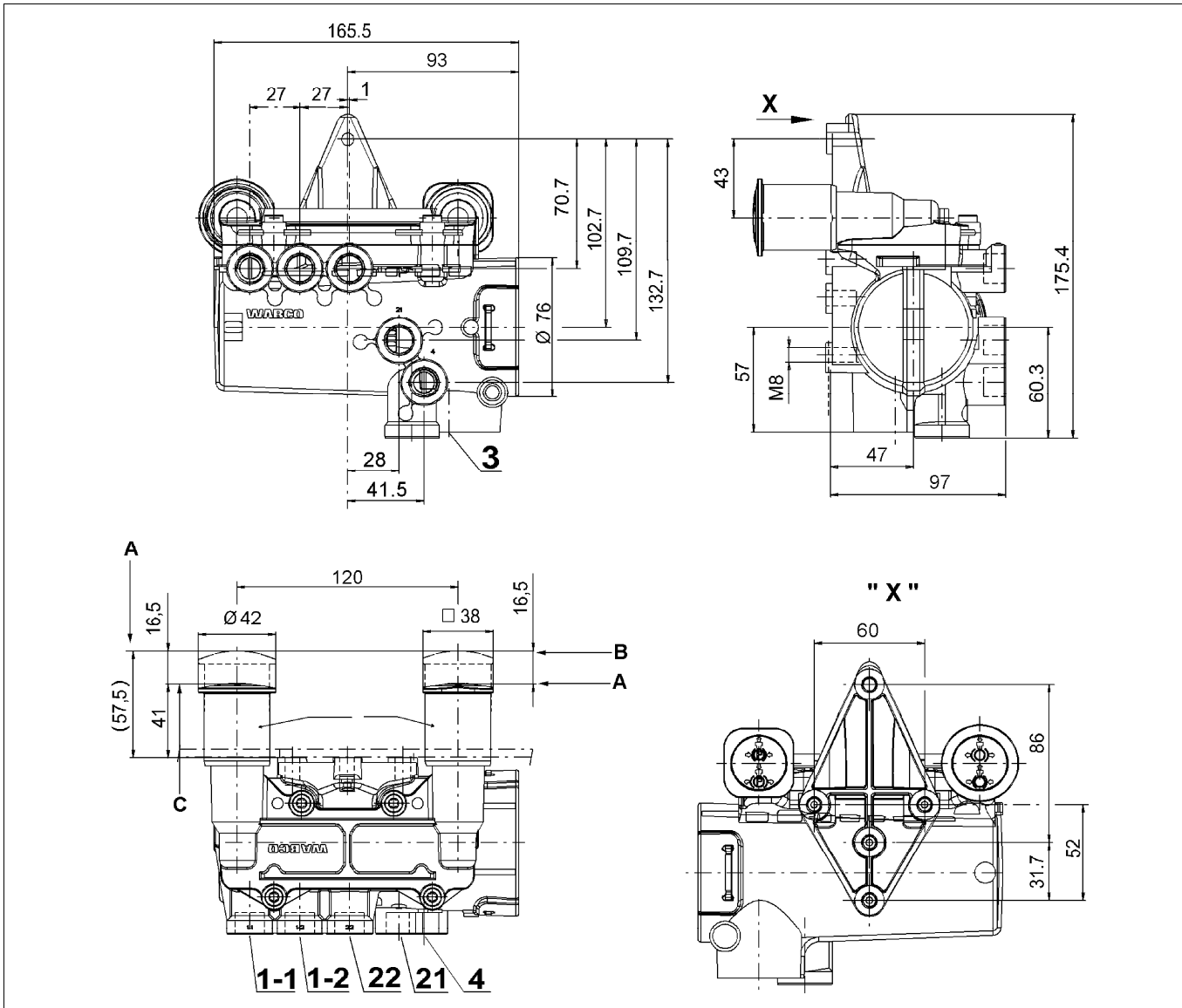

Key		
A	Driving position	B Parking position
		C Release position

Technical data

Order number	971 002 900 0	971 002 902 0	971 002 910 0	971 002 911 0	971 002 912 0	971 002 913 0
Working pressure	p ₁₋₁ 8.5 bar					
Max. permissible operating pressure (brief)	p ₁₋₁ 10 bar					
installation restrictions	Maximum deviation of the device from the vertical $\pm 15^\circ$					
Thermal range of application	-40 °C to +65 °C					
Weight	1.6 kg		1.8 kg		1.9 kg	1.8 kg
Quickfit connections	No			Yes		

Plate with parking and driving symbols

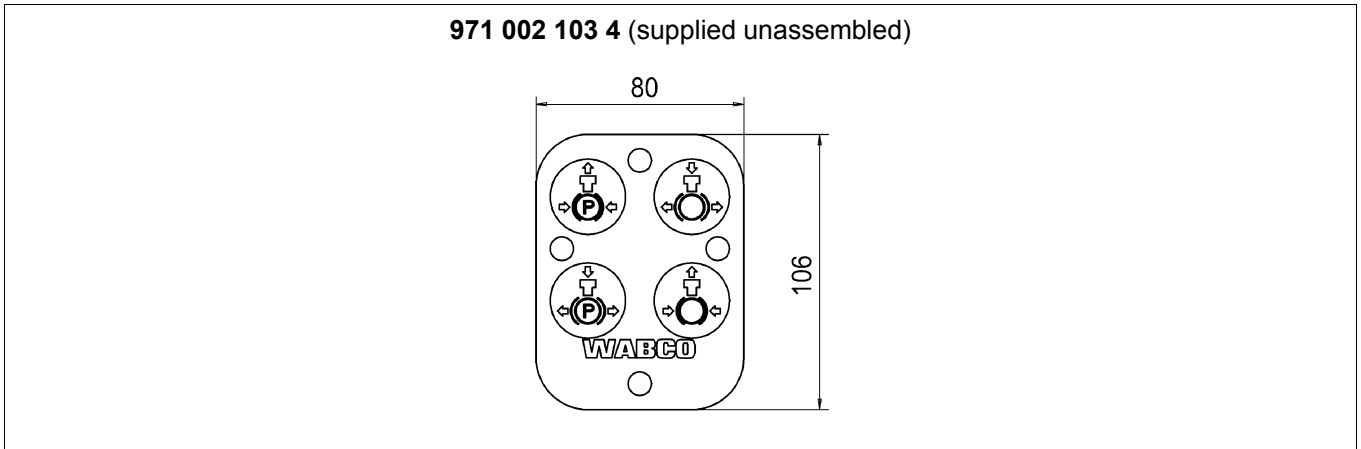

Pressure diagrams

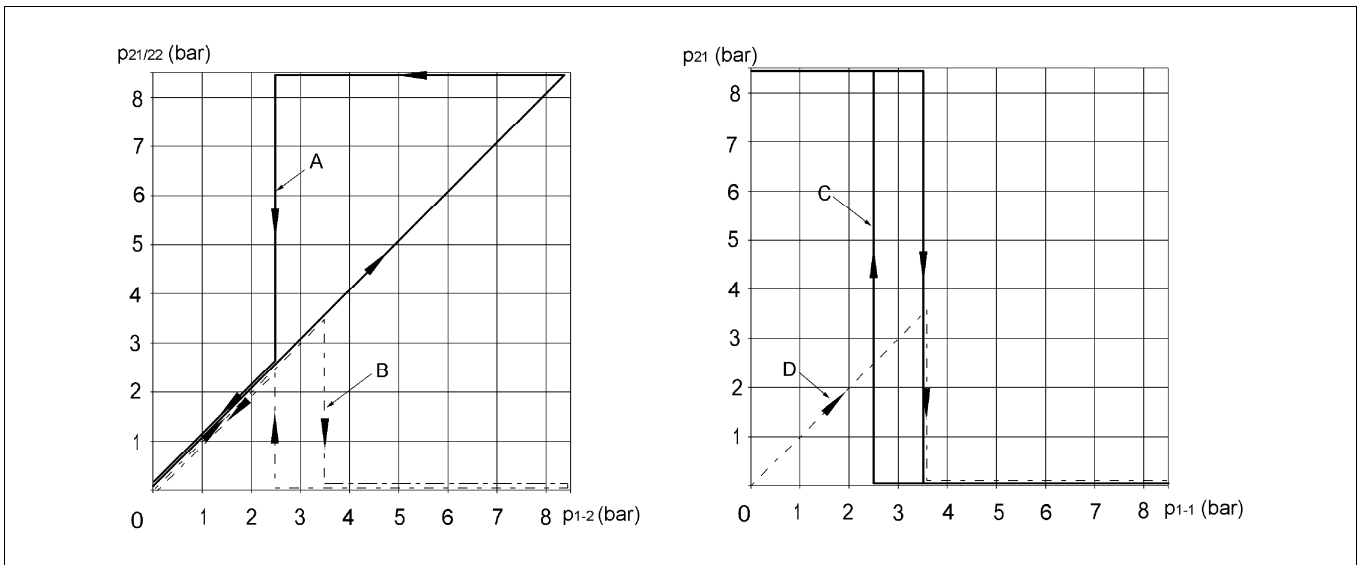

Key

p_{1-1}	Input pressure	A	Spring brake cylinder 22	B	Modulator 21
p_{1-2}	Connection	C	Automatic braking	D	Initial fill
$p_{21}; p_{21/22}$	Output pressure				

5.35 Relay valve 973 0..

973 001 010 0
973 001 020 0



973 011 000 0



Application

With especially large brake cylinder volumes

Purpose

To rapidly increase or decrease the pressure of compressed air equipment and to shorten the response and pressure build-up times in air braking systems

Maintenance

Special maintenance that extends beyond the legally specified inspections is not required.

Installation recommendation

- Install the relay valve so that vent 3 points downward.
- Fasten the relay valve with either two of the four housing fastening bolts M8.

Installation dimensions

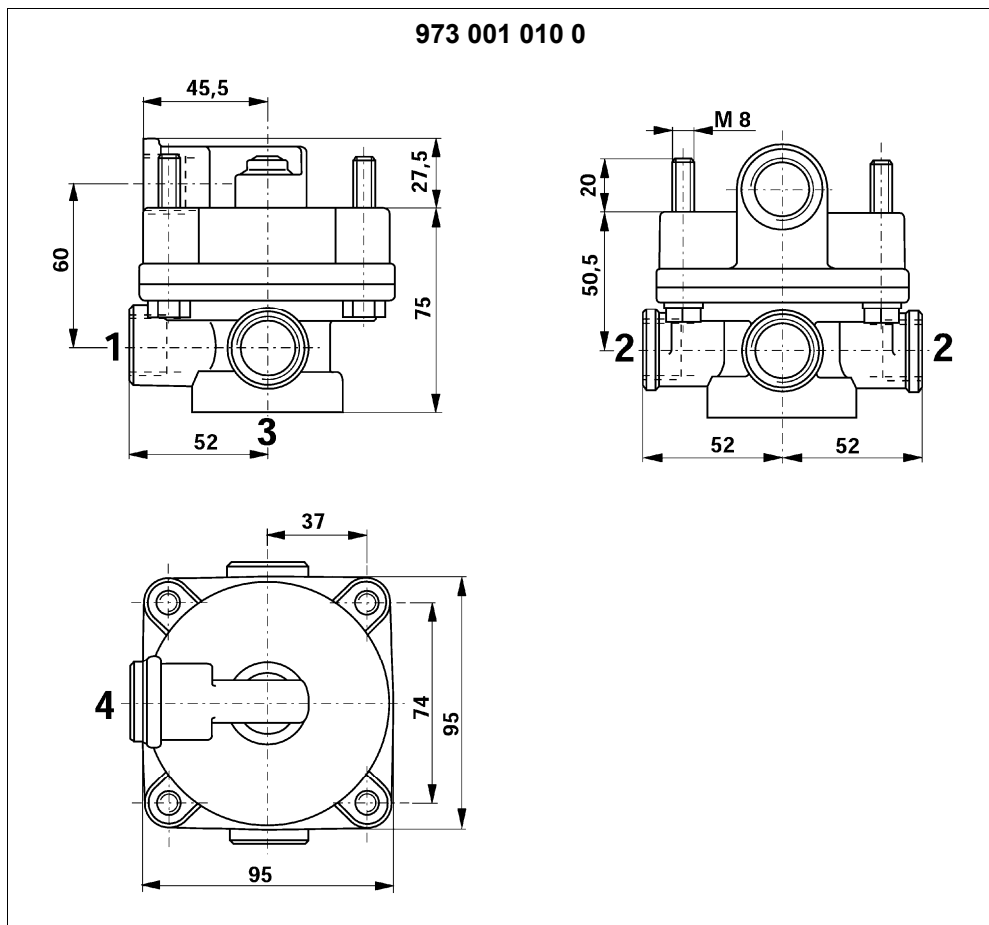

Connections

1	Energy supply	2	Energy delivery	3	Exhaust	4	Control port
----------	---------------	----------	-----------------	----------	---------	----------	--------------

Installation dimensions

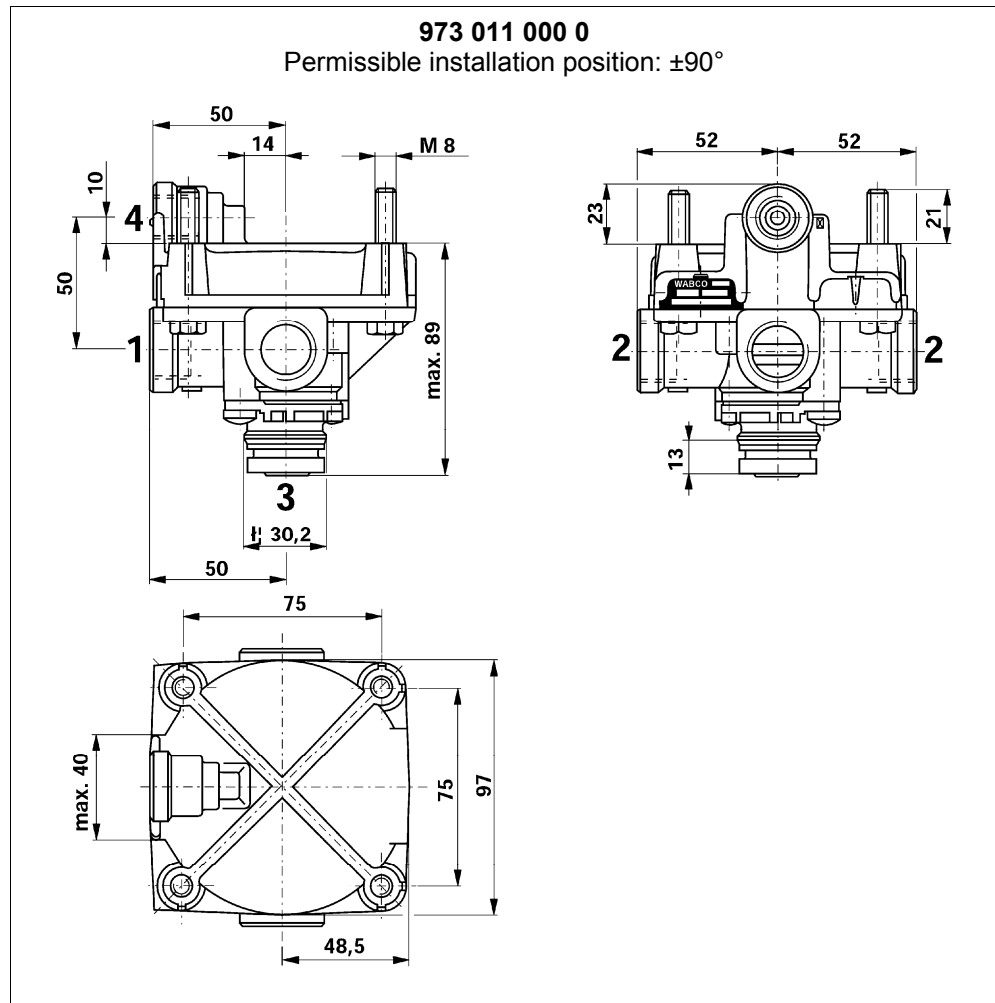

Connections

1 Energy supply 2 Energy delivery 3 Exhaust 4 Control port

Technical data

Order number	973 001 010 0	973 001 020 0	973 011 000 0
Max. supply pressure	22 bar		13 bar
Output pressure p_2	8 bar		10 bar
Control pressure p_4	8 bar (Max. operating pressure: 10 bar)	8 bar	10 bar
Port threads	M 22x1.5 - 14 deep	1 = M 22x1.5 - 14 deep 2, 4 = M 16x1.5 - 14 deep	1, 2 = M 22x1.5 - 13 deep 4 = M 16x1.5 - 12 deep
Thermal range of application	-40 °C to +80 °C		
Weight	1.1 kg		0.62 kg

Pressure diagrams

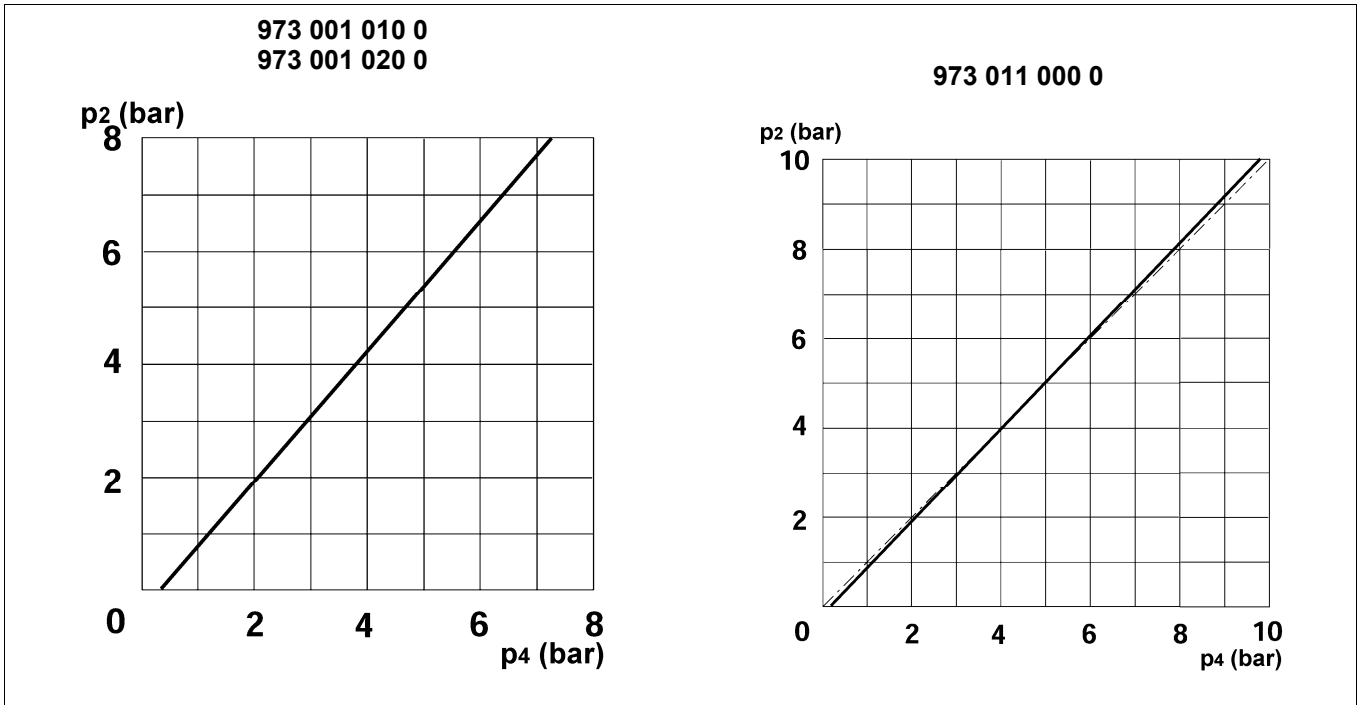

Key			
p_2	Output pressure	p_4	Control pressure

Overload protection Relay valve 973 011 201 0



Application

Especially with drum-brake vehicles

Purpose

For the protection of the wheel brake from overload (added force) when service and parking brake are actuated simultaneously,

Quick charge and venting of the spring brake cylinders (Tristop® cylinders).

Trailer EBS E **with** PEM: The overload relay valve is already integrated in the pneumatic extension module (PEM).

Installation dimensions

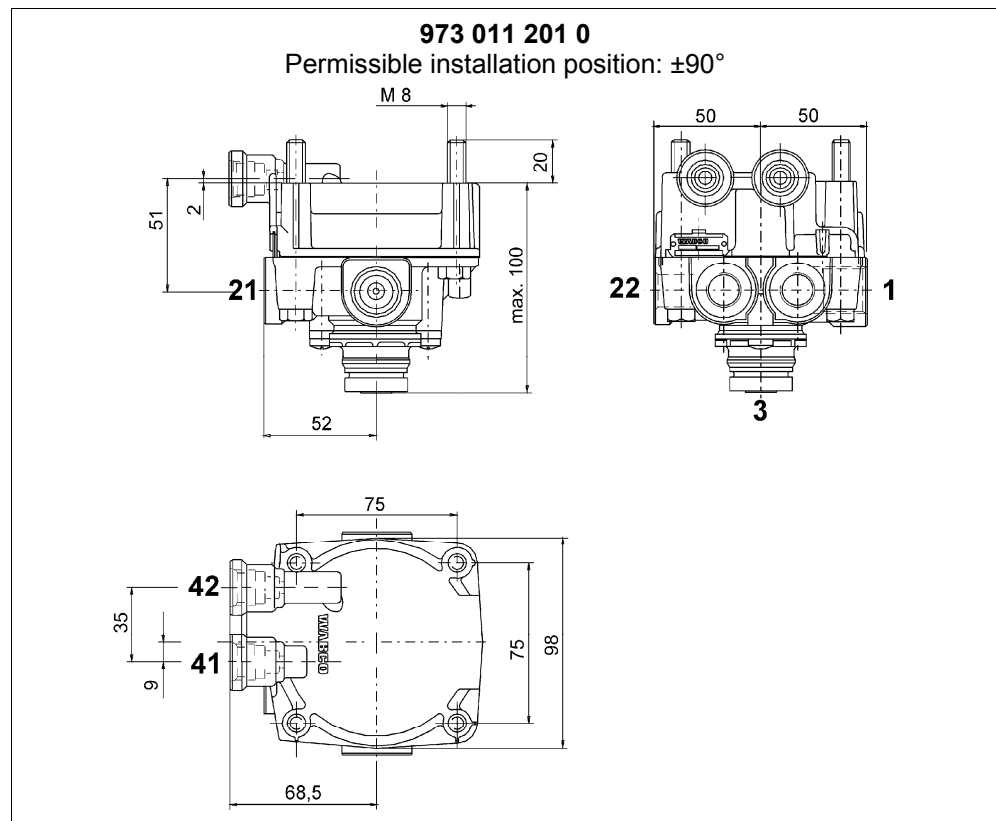

Technical data

Order number	973 011 201 0
Max. supply pressure	12 bar
Max. control pressure $p_{41/42}$	10 bar
Port threads	1 = M 22x1.5 ($M_{max.} = 53 \text{ Nm}$) M 16x1.5 ($M_{max.} = 34 \text{ Nm}$)
Thermal range of application	-40 °C to +80 °C

Diagram

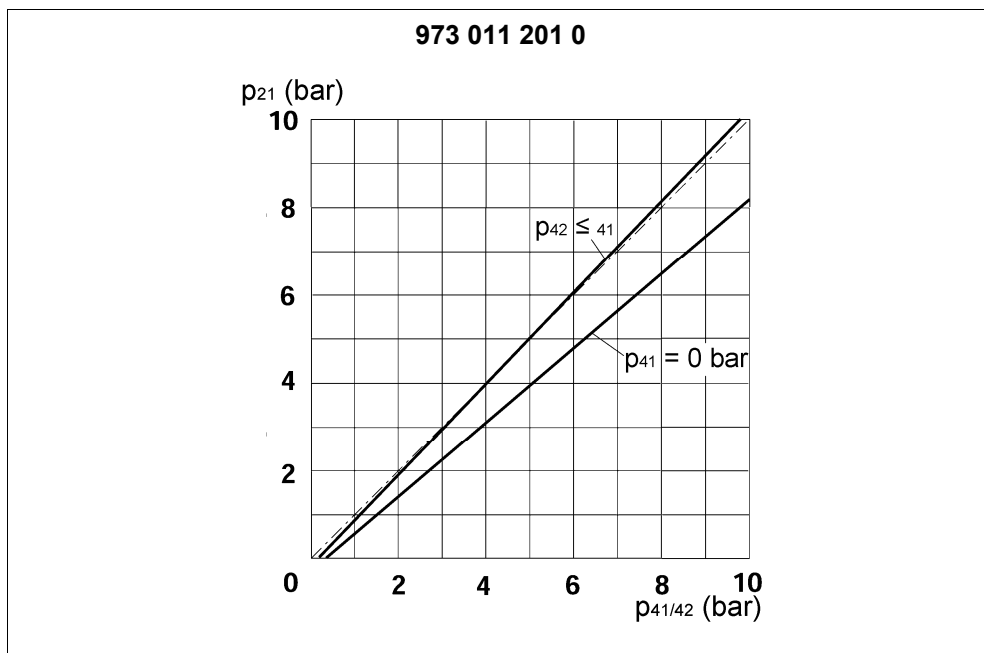

Key			
p_{21}	Output pressure	$p_{41/42}$	Control pressure

5.36 Proportioning pressure regulator 975 001 / 975 002

Proportioning pressure regulator with straight characteristic curve 975 001



Application

For trailers that require adapting to different brake pad wear on different axles.

Purpose

To reduce the braking force of the axle to be adapted during partial brake applications and rapid exhausting of brake actuators.

Trailers being operated in mountainous regions and frequently covering downhill journeys always show increased wear on the brake linings of the front wheels because the arrangement of the larger front-wheel brake actuators required for stopping will cause excess braking on the front axle. By using this adapter valve, the brake force on the front axle is reduced on the front axle to the extent that both axles are braked evenly; this does not, however, in any way impair the brake force in emergency braking.

Maintenance

Special maintenance that extends beyond the legally specified inspections is not required.

Installation recommendation

- Mount the adapter valve half way between the two brake cylinders of the axle to be adapted.
- Install the proportioning pressure regulator so that vent 3 points downward.
- Fasten the proportioning pressure regulator valve with two M8 bolts.

Installation dimensions

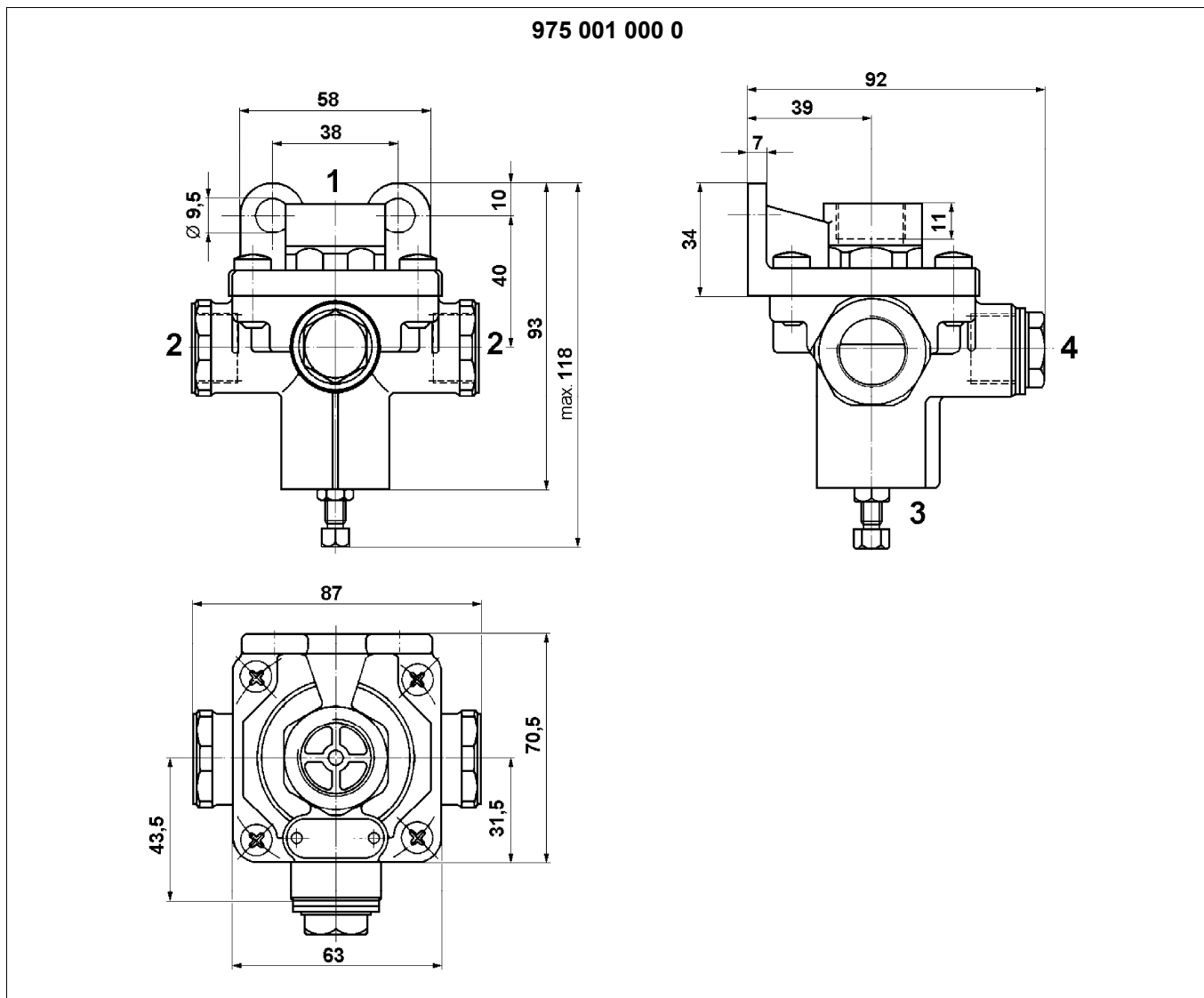

Connections			Port threads			
1	Energy supply	2	Energy delivery	3	Exhaust	M 22x1.5 - 15 deep

Installation dimensions

975 001 500 0: Combination proportioning pressure regulator 975 001 ... 0 with test valve 463 703 ... 0

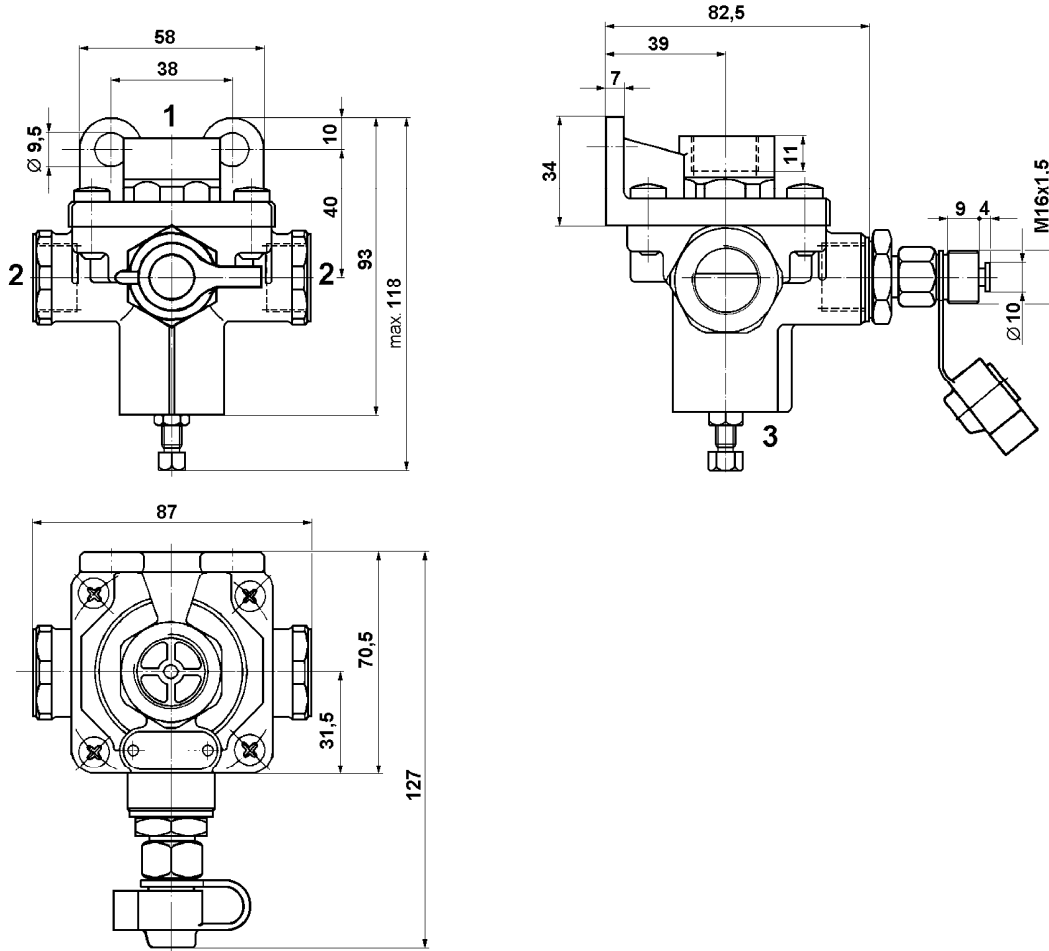

Connections

Port threads

1	Energy supply	2	Energy delivery	3	Exhaust	M 22x1.5 - 15 deep
---	---------------	---	-----------------	---	---------	--------------------

Technical data

Order number	975 001 000 0	975 001 001 0	975 001 002 0	975 001 500 0
Max. operating pressure	10 bar			
Range of adjustment	0.3 to 1.1 bar			
To be set at	0.7 ±0.1 bar	1 ±0.1 bar	0.5 ±0.1 bar	0.7 ±0.1 bar
Nominal diameter	12 mm			
Permissible medium	Air			
Thermal range of application	-40 °C to +80 °C			
Weight	0.55 kg			0.65 kg

Pressure diagrams

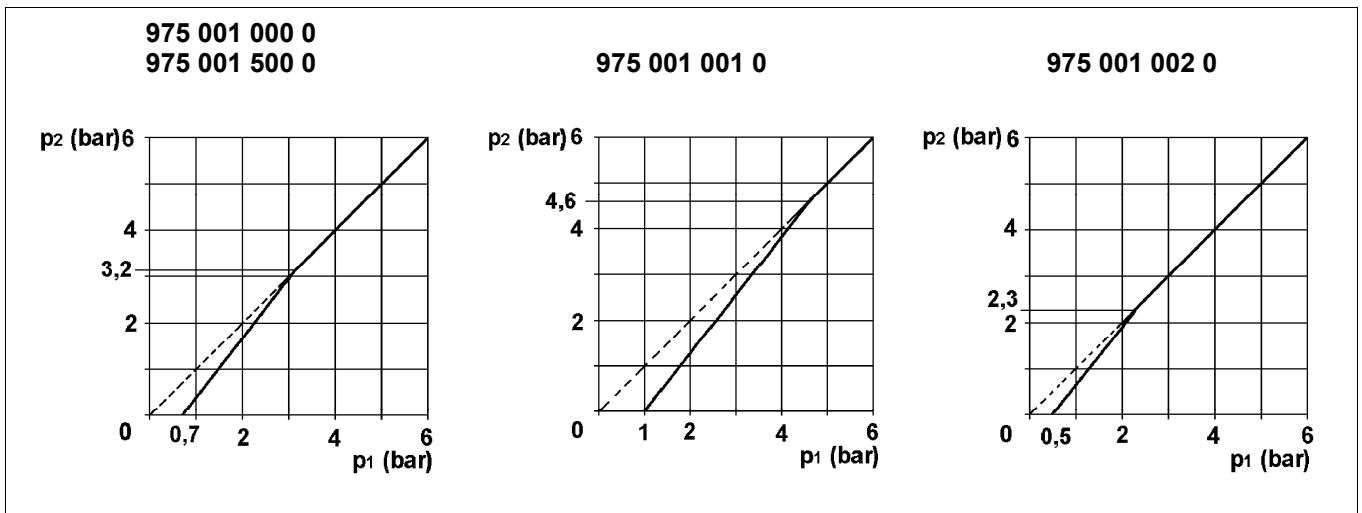

Proportioning pressure regulator with drop characteristic curve 975 002**Application**

For trailers, the brake force distribution of which must be adapted on one axle.

Purpose

To reduce the braking force of the axle to be adapted during partial brake applications and rapid exhausting of brake actuators.

Maintenance

Special maintenance that extends beyond the legally specified inspections is not required.

Installation recommendation

- Mount the adapter valve half way between the two brake cylinders of the axle to be adapted.
- Install the proportioning pressure regulator so that vent 3 points downward.
- Fasten the proportioning pressure regulator with the set screw on the side and an M8 nut.

Installation dimensions

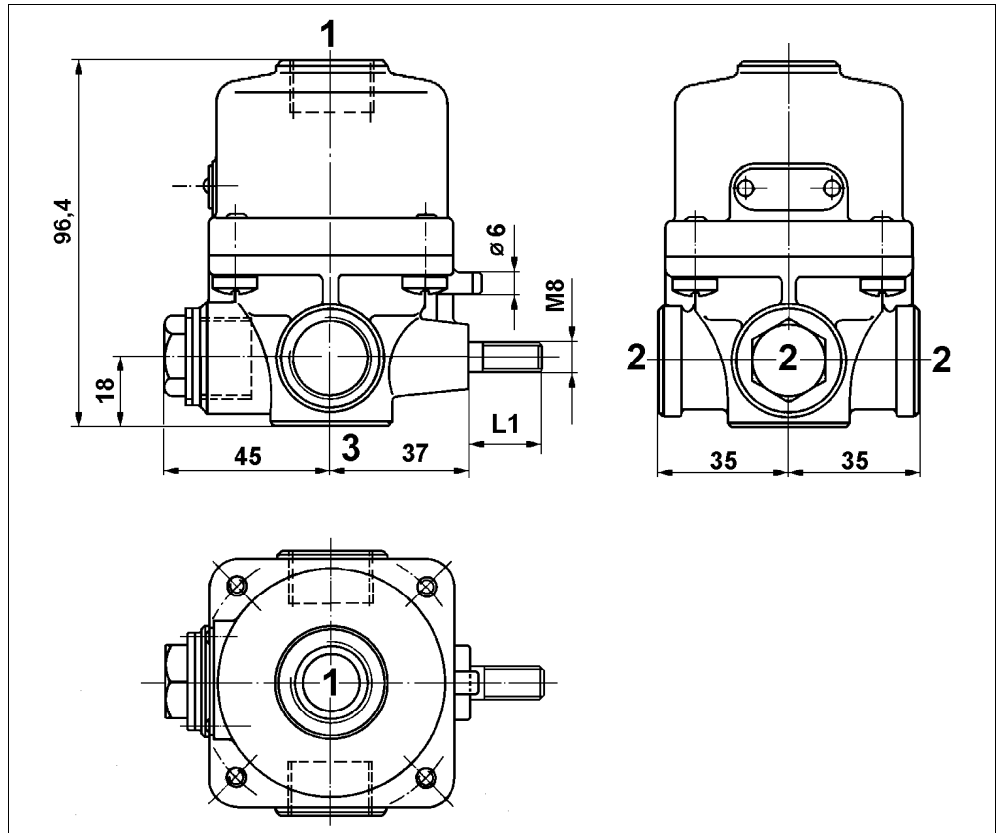

Technical data

Order number	975 002 017 0
Max. operating pressure	10 bar
Nominal diameter	7.5 mm
L1 (see Fig. "Installation Dimensions")	25 mm
Permissible medium	Air
Thermal range of application	-40 °C to +80 °C
Weight	0.60 kg

Diagram

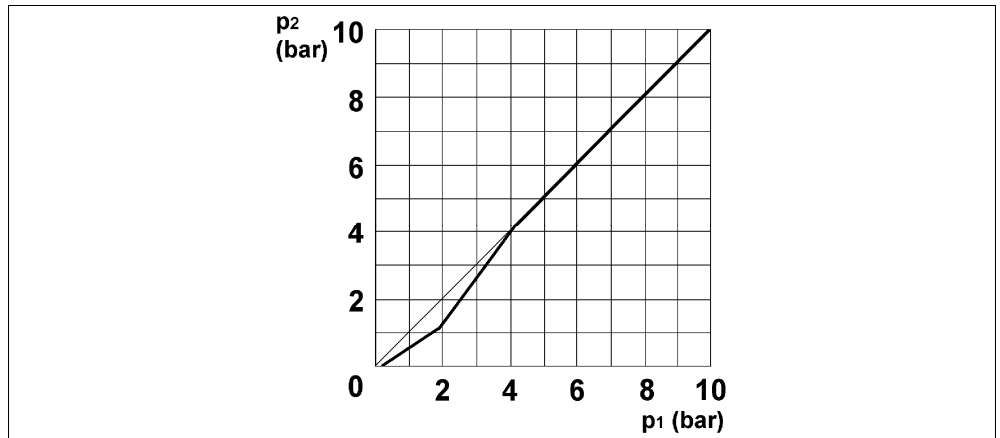

6 Disposal



Do not dispose of electronic devices, batteries, or accumulators together with household refuse. Instead it must be handed over to a designated collection point.

Observe the national and regional regulations.

Defective WABCO brake units can be returned to WABCO to guarantee the best possible processing.

Simply contact your WABCO partner.



WABCO Vehicle Control Systems (NYSE: WBC) is a leading supplier of safety and control systems for commercial vehicles. For over 140 years, WABCO has pioneered breakthrough electronic, mechanical and mechatronic technologies for braking, stability, and

transmission automation systems supplied to the world's leading commercial truck, trailer, and bus manufacturers. WABCO is headquartered in Brussels, Belgium. For more information, visit

www.wabco-auto.com



WABCO