

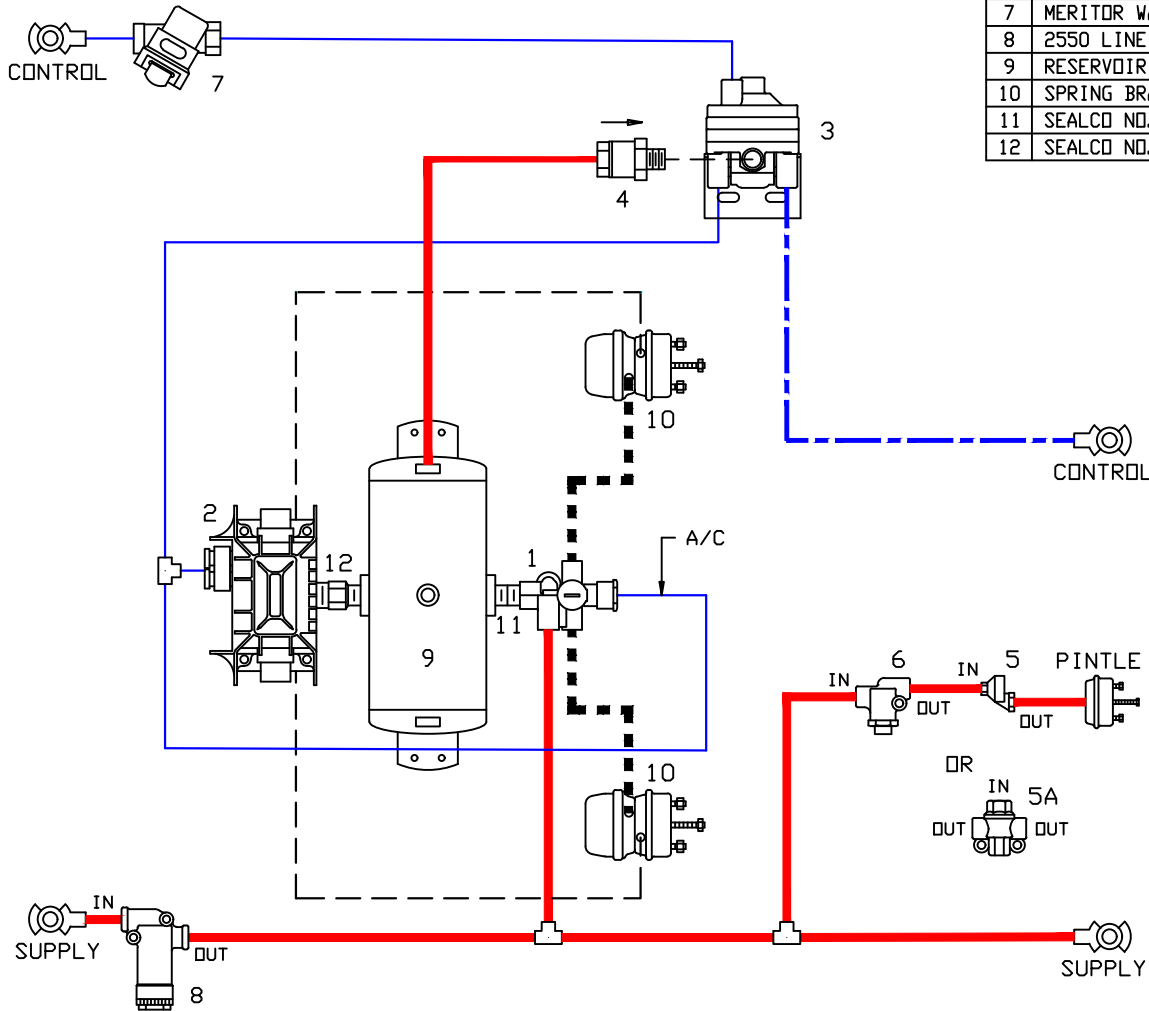

Sealco Commercial Vehicle Products

602-253-1007 fax 800/222-2334 www.sealcocvp.com

NO.	DESCRIPTION
1	SEALCO NO. 110800 SPRING BRAKE VALVE
2	MERITOR WABCO NO. 400 500 101 0 ECU ASSEMBLY AND RELAY VALVE
3	SEALCO NO. 110580 CONTROL LINE VALVE
4	SEALCO NO. 10200-1/2 ONE-WAY CHECK VALVE
5	SEALCO NO. 3800 OR (5A) 7800 SPRING BRAKE EXHAUST VALVE
6	SEALCO NO. 110257 EMERGENCY BRAKE PRESSURE PROTECTION VALVE
7	MERITOR WABCO NO. 432 500 005 0 CONTROL LINE FILTER (OPTIONAL)
8	2550 LINE FILTER (OPTIONAL)
9	RESERVOIR VOLUME AS PER FMVSS 121
10	SPRING BRAKE AND SERVICE BRAKE CHAMBER
11	SEALCO NO. 616 1/2" X 3/4" NIPPLE OR 6002 1/2" X 3/4" NIPPLE
12	SEALCO NO. 616 1/2" X 3/4" NIPPLE OR 6006 3/4" X 3/4" NIPPLE



## TO COMPLY WITH:

CANADIAN NATIONAL SAFETY CODE STANDARD 11  
 (MAINTENANCE AND PERIODIC INSPECTION STANDARD):  
 SECTION 13. AIR SYSTEM COMPONENTS  
 LINE e) NO AIR SYSTEM ACCESSORY DEVICE THAT  
 DRAWS AIR FROM THE AIR BRAKE SYSTEM SHALL  
 OPERATE WITHOUT A PROTECTION VALVE, AND  
 THE VALVE SHALL FUNCTION AS INTENDED.

IT IS THE RESPONSIBILITY OF THE VEHICLE  
 MANUFACTURER TO ASSURE THAT EACH VEHICLE  
 COMPLIES WITH FMVSS 121 AND ALL OTHER  
 APPLICABLE FEDERAL AND STATE REGULATIONS.

AIR SYSTEM REQUESTED BY:

SINGLE AXLE TRAILER DOUBLE

DRAWN BY:  
MG

CHECKED:

DATE:  
3-26-2020

DRAWING NO:  
P-7873