

This manual includes procedures for the installation of Sealco's Load Sensing Axle System (LSAS), setting the trigger pressure (on the trailer), and installing the optional status lamp system. The trigger pressure can be set before installation on the trailer. Please inquiry as to these procedures.

A great deal of care and caution should always be used when working with pressurized systems. Qualified installers should be knowledgeable about air brake, suspension and pressurized air systems. Wiring installation skills may be required for the status lamp system.

Installing The Valve Body

The valve body can be located outside of an enclosure but should not be located in areas that are subject to heavy splash or ice impact. The ports must aim downward.

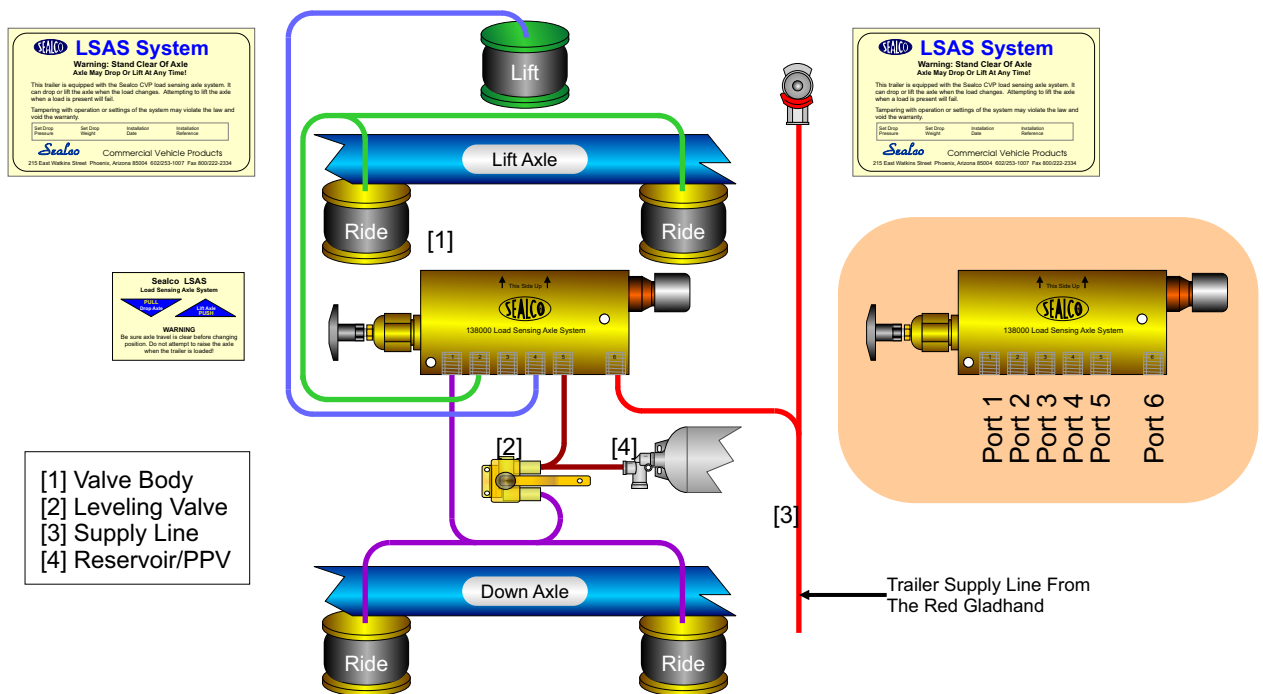

Chock all tires to prevent trailer from moving. Place stands under trailer if needed to perform work.

Drain air brake and suspension systems.

Mount valve to vehicle using the 1/4" mounting holes in the body. Be sure the ports aim downward.

Tighten weather cap. Install then tighten hand control knob and jam nut.

Install fitting in Port#1. Connect this port to one of the air springs on a non-lift axle.

Install fitting in Port #2. Connect this port to the ride air springs on the lift axle(s).

Install breather or drop tube in Port #3.

Install fitting into Port #4. Connect this port to the lift axle(s) lifting air springs.

Install fitting in Port #5. Connect this port to the air suspension's pressure protected supply.

Refill air brake and suspension system.

Install fitting in Port #6. Connect this port to the air brake systems' supply line.

Push knob in to test axle lift operation. Pull knob out to verify axle drop operation.

Adhere system label on both sides of the vehicle and the operational label near the valve body.

The LSAS's adjustable trigger fits a wide variety of trailer and suspension designs. These procedures describe the steps to set the trigger pressure with the valve on the trailer using a test fixture (described below).

The LSAS valve is designed to react slowly to pressure changes. This is necessary for proper operation. Please allow plenty of time for the valve to change mode (fully drain or fill) and for the system to refill.

It is not unusual to repeat some sections more than once to get the correct setting.

Section 1. Setup System

Chock the vehicle wheels.
 Drain the air brake system & suspension.
 Refer Figure #1
 From the adjuster remove the vinyl cap, the stainless steel set pin and the security seal (if present).
 Install test fixture and refill the system (Figure #1).
 Adjust the test fixture regulator output to the desired trigger pressure.

Section 2. Set The Trigger High

This step can be skipped if the valve is factory set (high).

Turn fixture valve off then push the LSAS knob
 Turn test fixture valve on and wait 30 seconds.
 If the LSAS knob does not pop out go to Section 3.
 Turn the fixture valve off.
 Refer Figure #2.
 Set the trigger higher by rotating the cap screw clockwise.
 Repeat this section.

Section 3. Setting The Trigger

Turn fixture valve off and push LSAS knob in.
 Turn the test fixture valve on and wait 30 seconds.
 If the LSAS knob pops out go to Section 4.
 Slowly turn the adjuster cap counter clockwise 60 degrees (one hole) waiting five seconds between until the knob pops out.
 Repeat this section.

Section 4. Verify Setting

Adjust the regulator 2 to 5 pounds under the desired pressure.
 Push the LSAS knob in and turn the fixture valve on.
 Wait 30 seconds.
 If the knob pops out repeat Sections 2 to 4.
 Adjust the regulator to the desired trigger pressure.
 Wait 30 seconds.
 If the valve's knob does not pop out repeat Section 3.

Section 5. Reset System

Remove air source, drain the brakes and the suspension.
 Remove the fixture from system,
 Re-install the lines to ports #1 & 6 and refill the system.
 Verify the system operation by raising and lowering the axle.
 Verify status lamp operation (if installed)

Section 6. Secure Adjuster

Refer to Figure #3.
 Turn the adjuster cap until one of the holes aligns with the base
 Install the stainless set pin through a hole on each pieces.
 Optionally install both of the seal leads through holes.
 Install the vinyl cap.

Test Fixture

It is recommended that a test fixture is used to verify the pressure setting (Figure #1).

The brake supply line pressure should be kept high during testing to fill reservoir, open the pressure protection valve and supply the test fixture.

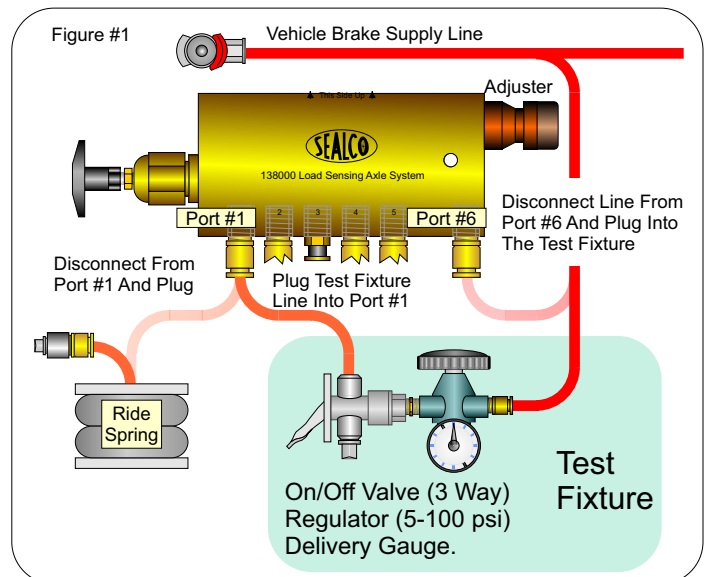
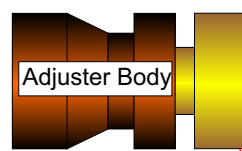
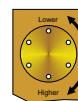

Figure #2

Trigger Adjuster



Adjuster Cap Head



80 PSI Setting (Factory Set)

Cap Head Flush With Body

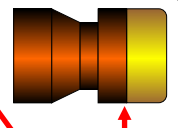

Important!

When Adjuster Cap Head Is Flush With Body Only Turn Counter Clockwise To Lower Pressure!

Turning the cap clockwise when it is flush with body can decalibrate the system.

Figure #3

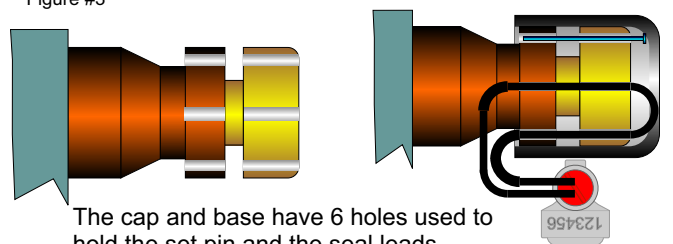

The cap and base have 6 holes used to hold the set pin and the seal leads

An optional set of modular wiring parts are available for the status lamp display of the lift axle's position. The display depends upon the presence of an ABS using the industry standard five pole Weatherpack power connector.

A high pressure switch is used to monitor the location of the lift axle (up or down). The switch can tap the line any where from port #4 to the lift spring of the axle. This design makes it unnecessary for the wiring to be located near the valve.

LED status lamps are recommended to minimize the current draw on the anti-lock brake system. Only LED status lamps should be used on older systems utilizing embedded switches.

Installation

1. Prevent vehicle from rolling and drain the brake and suspension systems.
2. Install the pressure switch any where in the line from valve port #4 to the lift spring. Attach the switch's power lead.
3. Locate the five pole weatherpack connector on the ABS power supply harness. Connect the power cable between the ABS valve cable and the harness's outlet cable.
4. Connect the power cable outlet to the switch harness. Use an extension lead if necessary.
5. Connect the switch harness to the status lamp lead. Use an extension lead if necessary.
6. Refill the air systems and check for leaks.
7. Power up the ABS through the constant (blue wire) circuit.
8. Push the valve's knob in. The axle(s) should lift and the lamp should turn on.
9. Pull the valve's knob out. The axle(s) should drop and the lamp should turn off.

Installation With 138HPS6 And 81002 Pressure Switch

Installation Notes
Remove the nuts from the switch terminals before attaching connector.
When mounting the switch outside aim the switch terminals upward.
The switch has a small vent between the terminals. Take care not to plug it.

Parts
1 = 138PC12 Power Cable Tap
2 = 138PEC Series Extension Cable
3 = 138SL Series Lamp Lead
4 = Status Lamp
5 = ABS ECU
6 = Lift Axle's Lift Spring
7 = 138HPS6 Switch Connector
8 = 81002 High Pressure Switch
9 = Pipe Tee

Installation With 8100 Series High Pressure Switch And 138SW Series Lead

Installation Notes
Attach one terminal of the 138SW harness to each post on the pressure switch. It does not matter which terminal is on which post.

The exposed terminals can be vulnerable to corrosion. Enclose the switch or use other suitable measure to protect them.

Parts
1 = 138PC12 Power Cable Tap
2 = 138PEC Series Extension Cable
3 = 138SL Series Lamp Lead
4 = Status Lamp
5 = ABS ECU
6 = Lift Axle's Lift Spring
7 = 138SW Switch Lead
8 = 8100 Series High Pressure Switch
9 = Pipe Tee

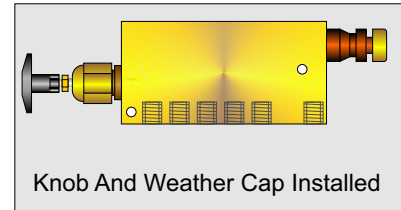
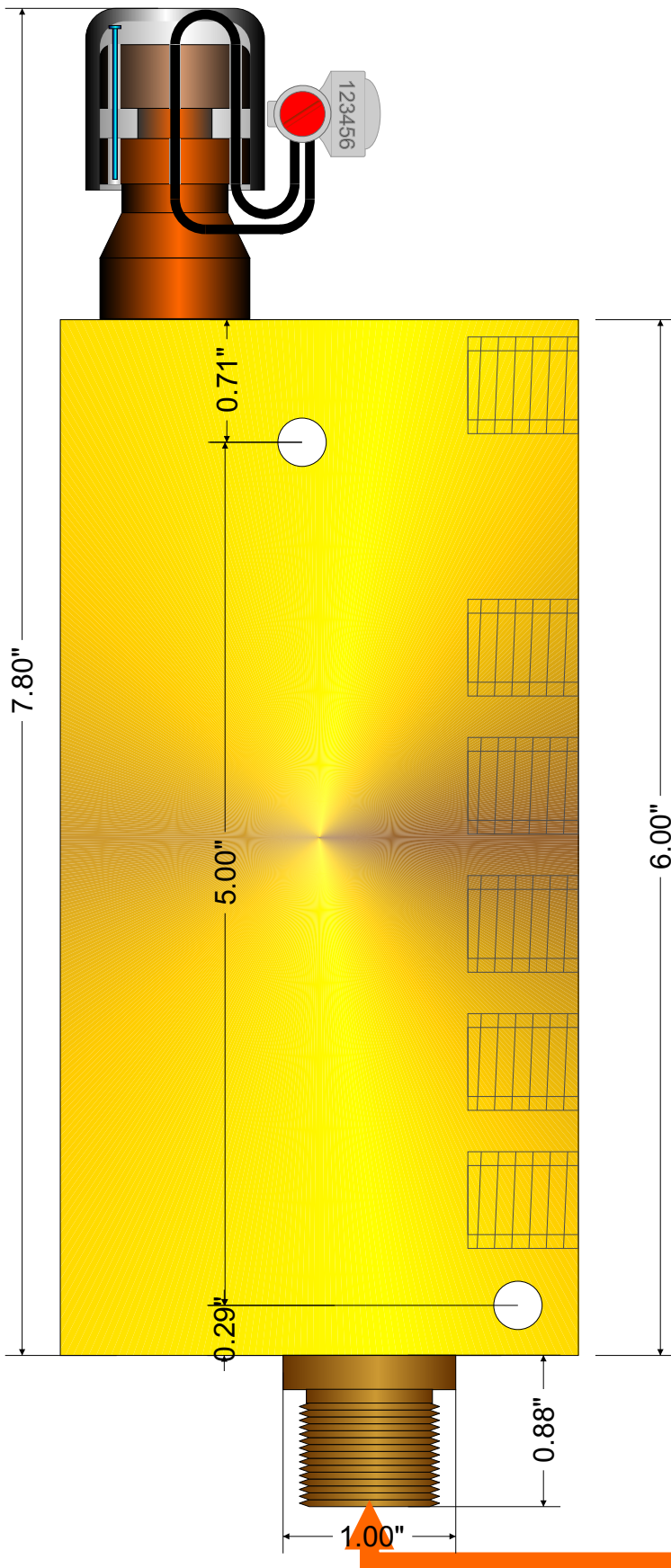

Actual Size

- All Pneumatic Ports Are 1/4" NPT
- Mounting Holes For 1/4" Bolts
- 1.25 Inch Thick Body
- 13/16" Threaded Neck & Weather Cap
- Designed For Pneumatic Operation Only

Overall Length Changes With Pressure Adjustment

