

RELAY EMERGENCY VALVES

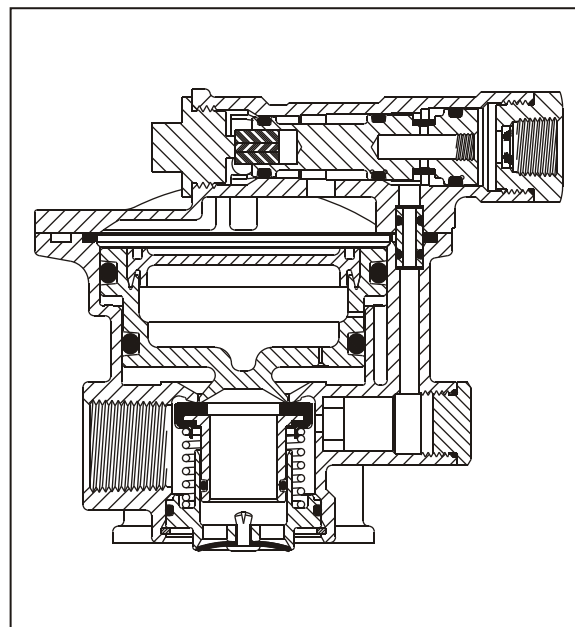

Relay Emergency Valves – Charging (4 Delivery Ports)

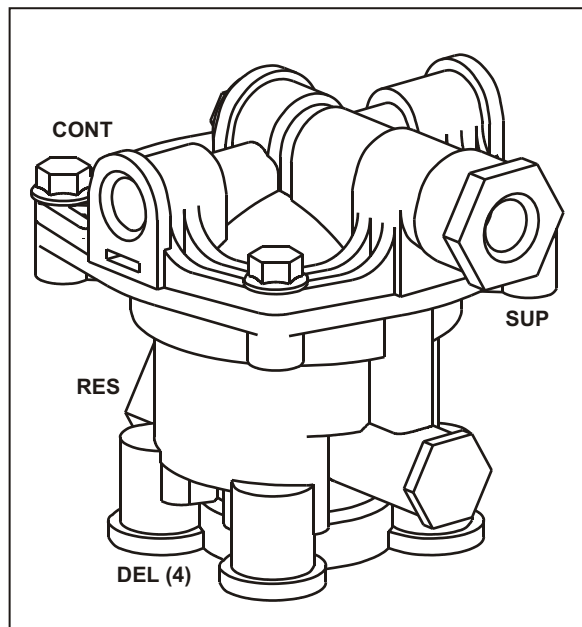

- The Ratio Feature is considered a benefit in hard stop situations & refers to the relationship between the control air pressure to the valve & the delivered air pressure from the valve to the service brake chambers. During normal stopping a 1:1 ratio exists between the control & delivered air pressures. In a hard stop the ratio momentarily changes to 1:1.5 until valve lap-off occurs & the 1:1 ratio is restored. This change takes place in less than 1/100th of a second.
 - Do not use ratio feature valves on converter dollies or trailer turnable axles
 - Mounting Hardware on pages 61 & 62
 - Piping examples on page 69
 - **PLUG UNIT ASSEMBLY 110143**
 - **MAJOR REPAIR KIT 110201**
 - **SPOOL ASSEMBLY 110162**
 - **MINOR SPOOL KIT 110166**
- * No Plug Unit available for this part number

PART NUMBER	PORT SIZES (NPT)					RATIO FEATURE	NOMINAL CRACK PRESSURE
	Supply	Control	Reservoir	Delivery	Sup. Out		
110200	1/4"	1/4"	3/4"	3/8"	-	Yes	4.5 psi
110205	3/8"	3/8"	3/4"	3/8"	-	Yes	4.5 psi
110459 *	3/8"	3/8"	3/4"	3/8"	3/8"	No	8.5 psi
110460	1/4"	1/4"	3/4"	3/8"	-	No	4.5 psi
110470	3/8"	3/8"	3/4"	3/8"	-	No	4.5 psi
110475	3/8"	3/8"	3/4"	3/8"	3/8"	No	4.5 psi