

# MISCELLANEOUS VALVES

## Line Filter

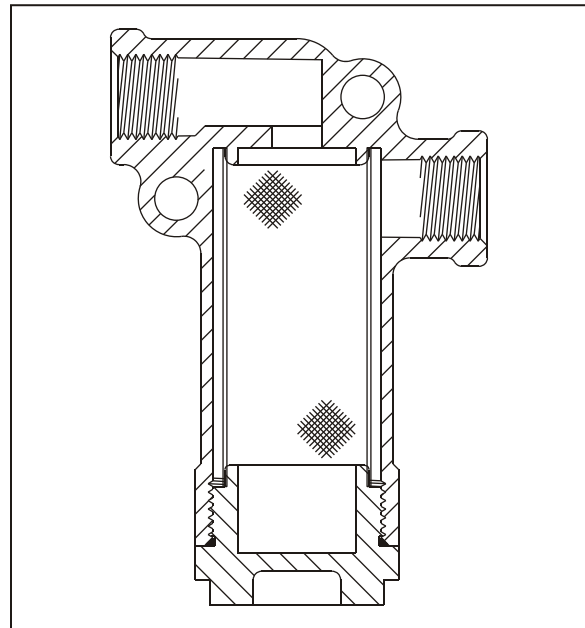
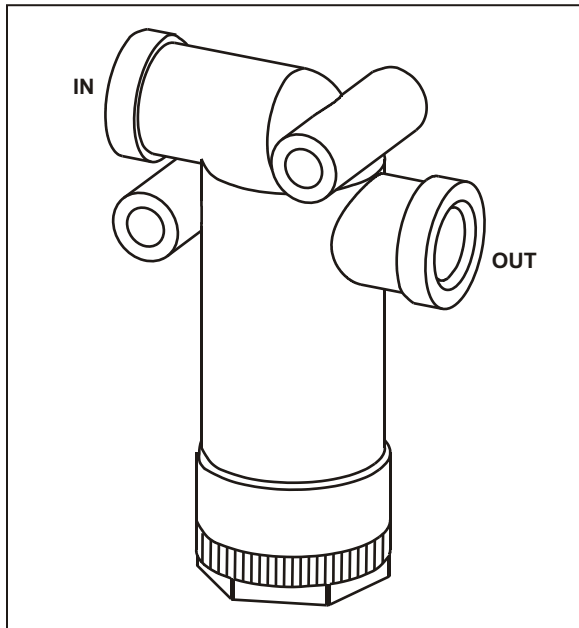

### INFORMATION:

- Commonly used in trailer supply line ahead of Spring Brake Control Valve or Emergency Relay Valve
- Reduces supply line contamination to extend the life of other air valves in the system
- The internal filter has 8 square inches of filter area & is removable for cleaning purposes
- Line Filter may only be mounted vertically to insure proper operation
- Piping examples on pages 70, 71, 72, 73 & 74
- **PLUG UNIT ASSEMBLY 2550-5**
- **NOTE: USE OF THIS LINE FILTER IN THE CONTROL LINE IS NOT RECOMMENDED**

PART NUMBER	PORT SIZES (NPT)	
	Inlet	Outlet
2550	3/8"	3/8"